



PCA9539; PCA9539R

16-bit I²C-bus and SMBus low power I/O port with interrupt and reset

Rev. 9 — 8 November 2017

Product data sheet

1. General description

The PCA9539; PCA9539R is a 24-pin CMOS device that provides 16 bits of General Purpose parallel Input/Output (GPIO) expansion with interrupt and reset for I²C-bus/SMBus applications and was developed to enhance the NXP Semiconductors family of I²C-bus I/O expanders. I/O expanders provide a simple solution when additional I/O is needed for ACPI power switches, sensors, push buttons, LEDs, fans, etc.

The PCA9539; PCA9539R consists of two 8-bit configuration (input or output selection), input, output and polarity inversion (active HIGH or active LOW operation) registers. The system master can enable the I/Os as either inputs or outputs by writing to the I/O configuration bits. The data for each input or output is kept in the corresponding Input or Output register. The polarity of the read register can be inverted with the Polarity inversion register. All registers can be read by the system master.

The PCA9539; PCA9539R is identical to the PCA9555 except for the removal of the internal I/O pull-up resistor which greatly reduces power consumption when the I/Os are held LOW, replacement of A2 with $\overline{\text{RESET}}$ and a different address range.

The PCA9539; PCA9539R open-drain interrupt output is activated when any input state differs from its corresponding input port register state and is used to indicate to the system master that an input state has changed.

The power-on reset sets the registers to their default values and initializes the device state machine. In the PCA9539, the $\overline{\text{RESET}}$ pin causes the same reset/default I/O input configuration to occur without de-powering the device, holding the registers and I²C-bus state machine in their default state until the $\overline{\text{RESET}}$ input is once again HIGH. This input requires a pull-up to V_{DD} . In the PCA9539R however, only the device state machine is initialized by the $\overline{\text{RESET}}$ pin and the internal general-purpose registers remain unchanged. Using the PCA9539R $\overline{\text{RESET}}$ pin will only reset the I²C-bus interface should it be stuck LOW to regain access to the I²C-bus. This allows the I/O pins to retain their last configured state so that they can keep any lines in their previously defined state and not cause system errors while the I²C-bus is being restored.

Two hardware pins (A0, A1) vary the fixed I²C-bus address and allow up to four devices to share the same I²C-bus/SMBus.

2. Features and benefits

- 16-bit I²C-bus GPIO with interrupt and reset
- Operating power supply voltage range of 2.3 V to 5.5 V (3.0 V to 5.5 V for PCA9539PW/Q900 and PCA9539RPW/Q900)
- 5 V tolerant I/Os



- Polarity inversion register
- Active LOW interrupt output
- Active LOW reset input
- Low standby current
- Noise filter on SCL/SDA inputs
- No glitch on power-up
- Internal power-on reset
- 16 I/O pins which default to 16 inputs
- 0 Hz to 400 kHz clock frequency
- ESD protection exceeds 2000 V HBM per JESD22-A114 and 1000 V CDM per JESD22-C101
- Latch-up testing is done to JEDEC Standard JESD78 which exceeds 100 mA
- Offered in three different packages: SO24, TSSOP24, and HVQFN24

3. Ordering information

Table 1. Ordering information

Type number	Topside marking	Package		
		Name	Description	Version
PCA9539BS	9539	HVQFN24	plastic thermal enhanced very thin quad flat package; no leads; 24 terminals; body 4 × 4 × 0.85 mm	SOT616-1
PCA9539RBS	539R	HVQFN24	plastic thermal enhanced very thin quad flat package; no leads; 24 terminals; body 4 × 4 × 0.85 mm	SOT616-1
PCA9539D	PCA9539D	SO24	plastic small outline package; 24 leads; body width 7.5 mm	SOT137-1
PCA9539PW	PCA9539PW	TSSOP24	plastic thin shrink small outline package; 24 leads; body width 4.4 mm	SOT355-1
PCA9539PW/Q900 ^[1]	PCA9539PW	TSSOP24	plastic thin shrink small outline package; 24 leads; body width 4.4 mm	SOT355-1
PCA9539RPW	PA9539RPW	TSSOP24	plastic thin shrink small outline package; 24 leads; body width 4.4 mm	SOT355-1
PCA9539RPW/Q900 ^[1]	PA9539RPW	TSSOP24	plastic thin shrink small outline package; 24 leads; body width 4.4 mm	SOT355-1

[1] PCA9539PW/Q900 and PCA9539RPW/Q900 are AEC-Q100 compliant. Contact I2C.support@nxp.com for PPAP.

3.1 Ordering options

Table 2. Ordering options

Type number	Orderable part number	Package	Packing method	Minimum order quantity	Temperature
PCA9539BS	PCA9539BS,115	HVQFN24	Reel 7" Q1/T1 *standard mark SMD ^[1]	1500	T _{amb} = -40 °C to +85 °C
	PCA9539BS,118	HVQFN24	Reel 13" Q1/T1 *standard mark SMD ^[1]	6000	T _{amb} = -40 °C to +85 °C
	PCA9539BSHP	HVQFN24	Reel 13" Q2/T3 *standard mark SMD ^[2]	6000	T _{amb} = -40 °C to +85 °C

Table 2. Ordering options ...continued

Type number	Orderable part number	Package	Packing method	Minimum order quantity	Temperature
PCA9539RBS	PCA9539RBS,118	HVQFN24	Reel 13" Q1/T1 *standard mark SMD ^[1]	6000	T _{amb} = -40 °C to +85 °C
PCA9539D	PCA9539D,112	SO24	Standard marking * IC's tube - DSC bulk pack	1200	T _{amb} = -40 °C to +85 °C
	PCA9539D,118	SO24	Reel 13" Q1/T1 *standard mark SMD ^[1]	1000	T _{amb} = -40 °C to +85 °C
PCA9539PW	PCA9539PW,112	TSSOP24	Standard marking * IC's tube - DSC bulk pack	1575	T _{amb} = -40 °C to +85 °C
	PCA9539PW,118	TSSOP24	Reel 13" Q1/T1 *standard mark SMD ^[1]	2500	T _{amb} = -40 °C to +85 °C
PCA9539PW/Q900	PCA9539PW/Q900,118	TSSOP24	Reel 13" Q1/T1 *standard mark SMD ^[1]	2500	T _{amb} = -40 °C to +125 °C
PCA9539RPW	PCA9539RPW,118	TSSOP24	Reel 13" Q1/T1 *standard mark SMD ^[1]	2500	T _{amb} = -40 °C to +85 °C
PCA9539RPW/Q900	PCA9539RPWJ	TSSOP24	Reel 13" Q1/T1 *standard mark SMD ^[1]	2500	T _{amb} = -40 °C to +125 °C

[1] Pin 1 in Quadrant 1; see [Figure 2](#).

[2] Pin 1 in Quadrant 2; see [Figure 3](#).

3.1.1 Pin 1 quadrant indication

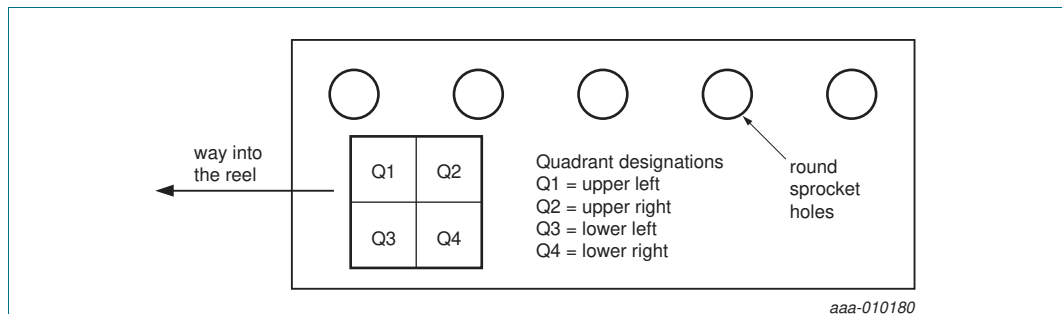

Fig 1. Carrier tape pin 1 quadrant designations

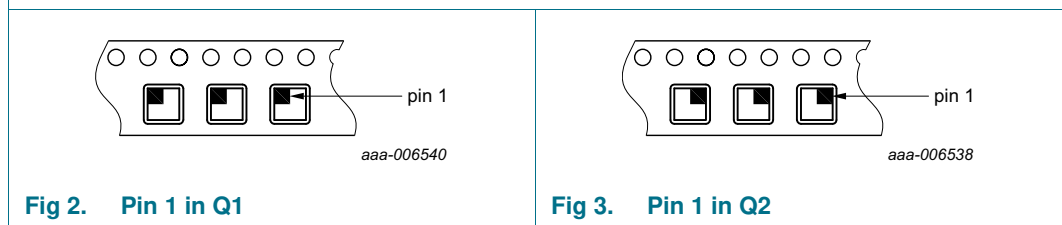
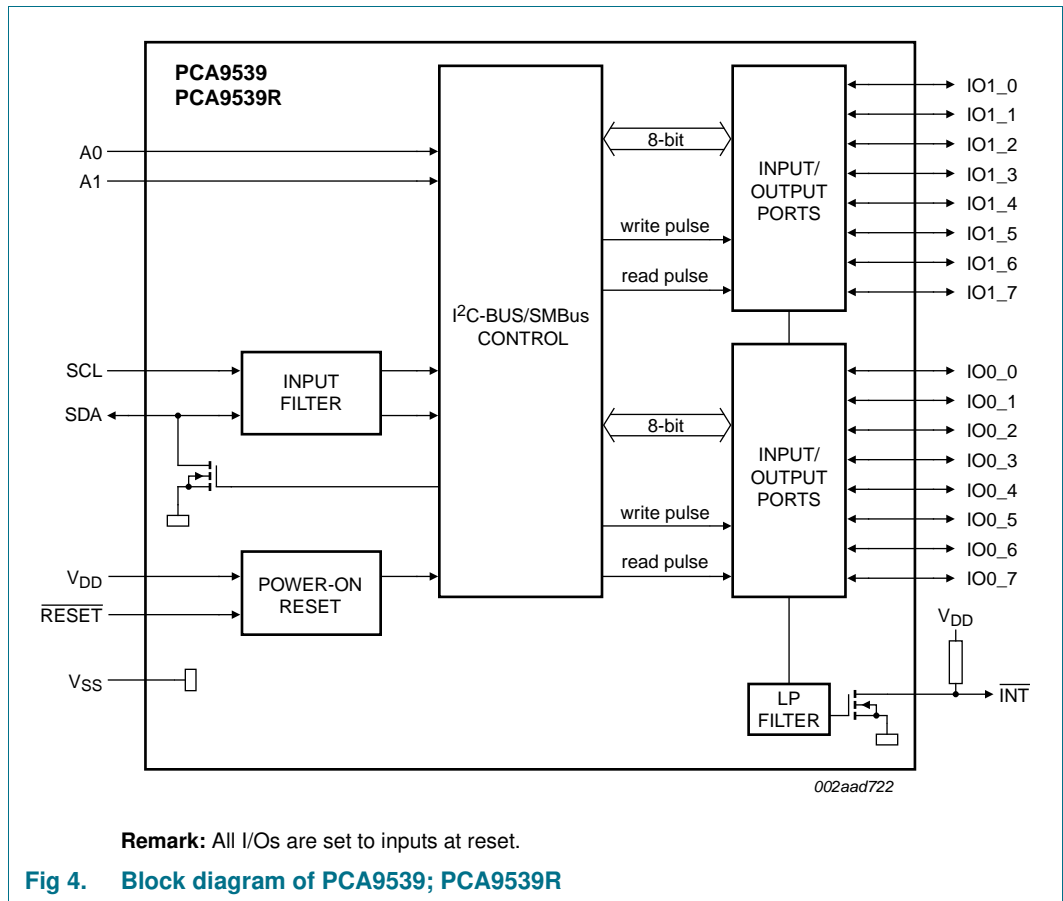

Fig 2. Pin 1 in Q1

Fig 3. Pin 1 in Q2

4. Block diagram



5. Pinning information

5.1 Pinning

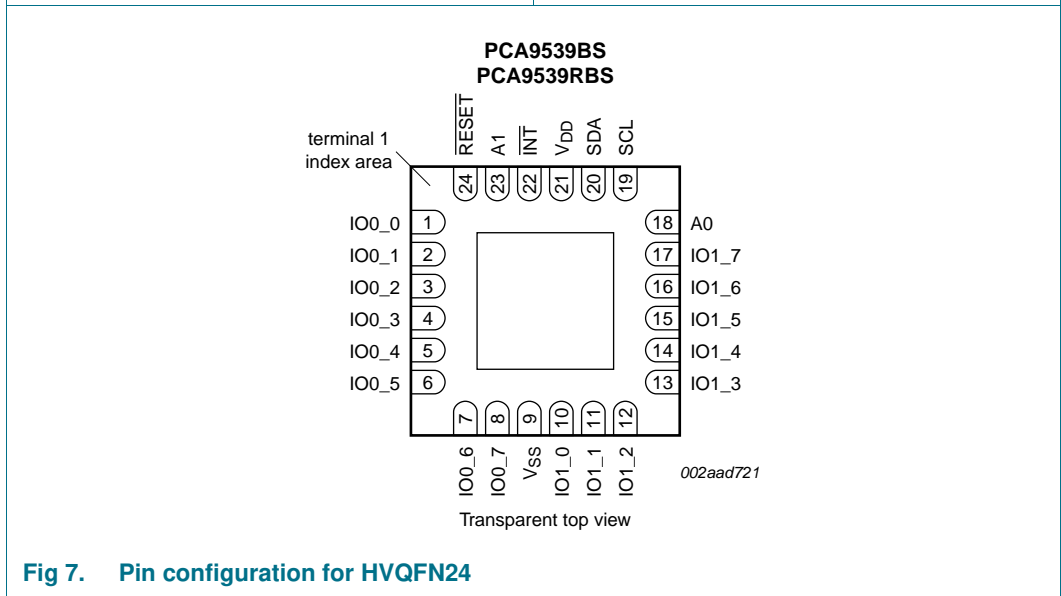
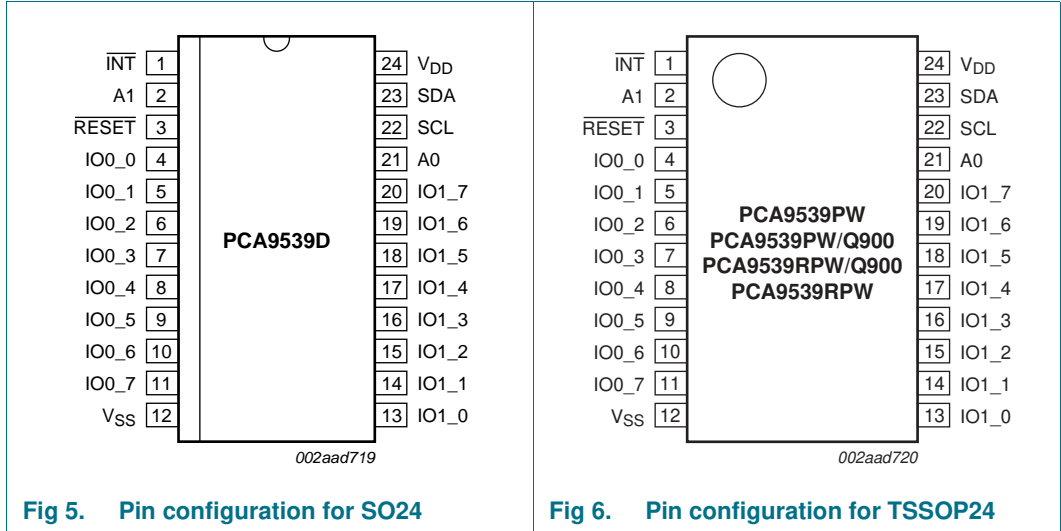

5.2 Pin description

Table 3. Pin description

Symbol	Pin		Description
	SO24, TSSOP24	HVQFN24	
$\overline{\text{INT}}$	1	22	interrupt output (open-drain)
A1	2	23	address input 1
$\overline{\text{RESET}}$	3	24	active LOW reset input. Driving this pin LOW causes: <ul style="list-style-type: none"> PCA9539 to reset its state machine and registers PCA9539R to reset its state machine, but has no effect on its registers
IO0_0	4	1	port 0 input/output 0
IO0_1	5	2	port 0 input/output 1
IO0_2	6	3	port 0 input/output 2
IO0_3	7	4	port 0 input/output 3
IO0_4	8	5	port 0 input/output 4
IO0_5	9	6	port 0 input/output 5
IO0_6	10	7	port 0 input/output 6
IO0_7	11	8	port 0 input/output 7
V _{SS}	12	9 ^[1]	supply ground
IO1_0	13	10	port 1 input/output 0
IO1_1	14	11	port 1 input/output 1
IO1_2	15	12	port 1 input/output 2
IO1_3	16	13	port 1 input/output 3
IO1_4	17	14	port 1 input/output 4
IO1_5	18	15	port 1 input/output 5
IO1_6	19	16	port 1 input/output 6
IO1_7	20	17	port 1 input/output 7
A0	21	18	address input 0
SCL	22	19	serial clock line input
SDA	23	20	serial data line open-drain input/output
V _{DD}	24	21	supply voltage

- [1] HVQFN24 package die supply ground is connected to both V_{SS} pin and exposed center pad. V_{SS} pin must be connected to supply ground for proper device operation. For enhanced thermal, electrical, and board level performance, the exposed pad needs to be soldered to the board using a corresponding thermal pad on the board and for proper heat conduction through the board, thermal vias need to be incorporated in the PCB in the thermal pad region.

6. Functional description

Refer to [Figure 4 “Block diagram of PCA9539; PCA9539R”](#).

6.1 Device address

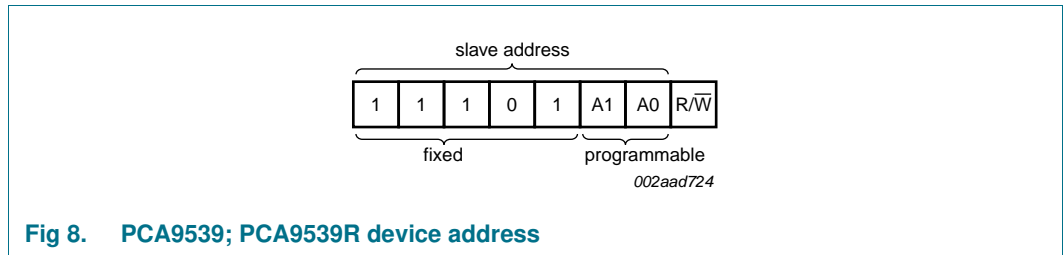

Fig 8. PCA9539; PCA9539R device address

6.2 Registers

6.2.1 Command byte

The command byte is the first byte to follow the address byte during a write transmission. It is used as a pointer to determine which of the following registers will be written or read.

Table 4. Command byte

Command	Register
0	Input port 0
1	Input port 1
2	Output port 0
3	Output port 1
4	Polarity inversion port 0
5	Polarity inversion port 1
6	Configuration port 0
7	Configuration port 1

6.2.2 Registers 0 and 1: Input port registers

This register is an input-only port. It reflects the incoming logic levels of the pins, regardless of whether the pin is defined as an input or an output by Register 3. Writes to this register have no effect.

The default value 'X' is determined by the externally applied logic level.

Table 5. Input port 0 register

Bit	7	6	5	4	3	2	1	0
Symbol	I0.7	I0.6	I0.5	I0.4	I0.3	I0.2	I0.1	I0.0
Default	X	X	X	X	X	X	X	X

Table 6. Input port 1 register

Bit	7	6	5	4	3	2	1	0
Symbol	I1.7	I1.6	I1.5	I1.4	I1.3	I1.2	I1.1	I1.0
Default	X	X	X	X	X	X	X	X

6.2.3 Registers 2 and 3: Output port registers

This register is an output-only port. It reflects the outgoing logic levels of the pins defined as outputs by Registers 6 and 7. Bit values in this register have no effect on pins defined as inputs. In turn, reads from this register reflect the value that is in the flip-flop controlling the output selection, **not** the actual pin value.

Table 7. Output port 0 register

Bit	7	6	5	4	3	2	1	0
Symbol	O0.7	O0.6	O0.5	O0.4	O0.3	O0.2	O0.1	O0.0
Default	1	1	1	1	1	1	1	1

Table 8. Output port 1 register

Bit	7	6	5	4	3	2	1	0
Symbol	O1.7	O1.6	O1.5	O1.4	O1.3	O1.2	O1.1	O1.0
Default	1	1	1	1	1	1	1	1

6.2.4 Registers 4 and 5: Polarity inversion registers

This register allows the user to invert the polarity of the Input port register data. If a bit in this register is set (written with '1'), the Input port data polarity is inverted. If a bit in this register is cleared (written with a '0'), the Input port data polarity is retained.

Table 9. Polarity inversion port 0 register

Bit	7	6	5	4	3	2	1	0
Symbol	N0.7	N0.6	N0.5	N0.4	N0.3	N0.2	N0.1	N0.0
Default	0	0	0	0	0	0	0	0

Table 10. Polarity inversion port 1 register

Bit	7	6	5	4	3	2	1	0
Symbol	N1.7	N1.6	N1.5	N1.4	N1.3	N1.2	N1.1	N1.0
Default	0	0	0	0	0	0	0	0

6.2.5 Registers 6 and 7: Configuration registers

This register configures the directions of the I/O pins. If a bit in this register is set (written with '1'), the corresponding port pin is enabled as an input with high-impedance output driver. If a bit in this register is cleared (written with '0'), the corresponding port pin is enabled as an output. At reset, the device's ports are inputs.

Table 11. Configuration port 0 register

Bit	7	6	5	4	3	2	1	0
Symbol	C0.7	C0.6	C0.5	C0.4	C0.3	C0.2	C0.1	C0.0
Default	1	1	1	1	1	1	1	1

Table 12. Configuration port 1 register

Bit	7	6	5	4	3	2	1	0
Symbol	C1.7	C1.6	C1.5	C1.4	C1.3	C1.2	C1.1	C1.0
Default	1	1	1	1	1	1	1	1

6.3 Power-on reset

When power is applied to V_{DD} , an internal power-on reset holds the PCA9539; PCA9539R in a reset condition until V_{DD} has reached V_{POR} . At that point, the reset condition is released and the PCA9539; PCA9539R registers and SMBus state machine will initialize to their default states. Thereafter, V_{DD} must be lowered below 0.2 V to reset the device.

For a power reset cycle, V_{DD} must be lowered below 0.2 V and then restored to the operating voltage.

6.4 $\overline{\text{RESET}}$ input

A reset can be accomplished by holding the $\overline{\text{RESET}}$ pin LOW for a minimum of $t_{w(\text{rst})}$. In the PCA9539 the registers and SMBus/I²C-bus state machine will be held in their default state until the $\overline{\text{RESET}}$ input is once again HIGH. This input typically requires a pull-up to V_{DD} . In the PCA9539R, only the device state machine is initialized. The internal general-purpose registers remain unchanged. Using the PCA9539R hardware reset pin will only reset the I²C-bus interface should it be stuck LOW to regain access to the I²C-bus. This allows the I/O pins to retain their last configured state so that they can keep any lines in their previously defined state and not cause system errors while the I²C-bus is being restored.

6.5 I/O port

When an I/O is configured as an input, FETs Q1 and Q2 are off, creating a high-impedance input. The input voltage may be raised above V_{DD} to a maximum of 5.5 V.

If the I/O is configured as an output, then either Q1 or Q2 is on, depending on the state of the Output port register. Care should be exercised if an external voltage is applied to an I/O configured as an output because of the low-impedance path that exists between the pin and either V_{DD} or V_{SS} .

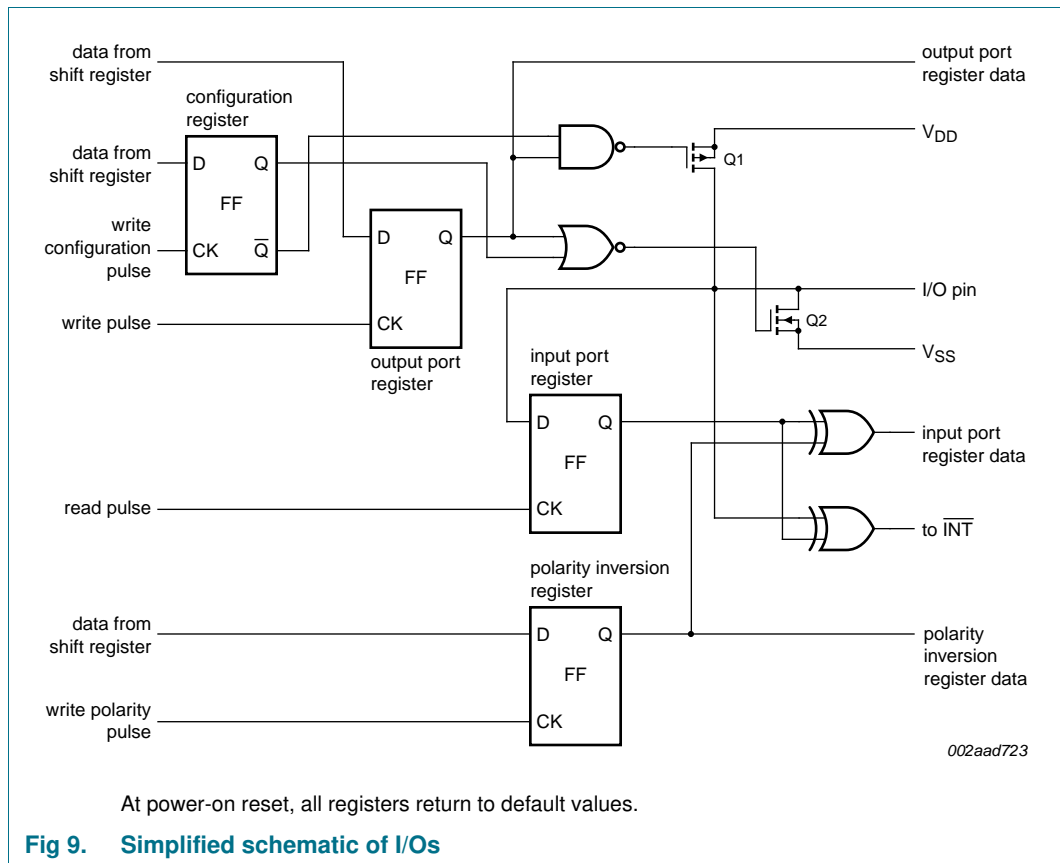

6.6 Bus transactions

6.6.1 Writing to the port registers

Data is transmitted to the PCA9539; PCA9539R by sending the device address and setting the least significant bit to a logic 0 (see [Figure 8 “PCA9539; PCA9539R device address”](#)). The command byte is sent after the address and determines which register will receive the data following the command byte.

The eight registers within the PCA9539; PCA9539R are configured to operate as four register pairs. The four pairs are Input ports, Output ports, Polarity inversion ports, and Configuration ports. After sending data to one register, the next data byte will be sent to the other register in the pair (see [Figure 10](#) and [Figure 11](#)). For example, if the first byte is sent to Output port 1 (register 3), then the next byte will be stored in Output port 0 (register 2). There is no limitation on the number of data bytes sent in one write transmission. In this way, each 8-bit register may be updated independently of the other registers.

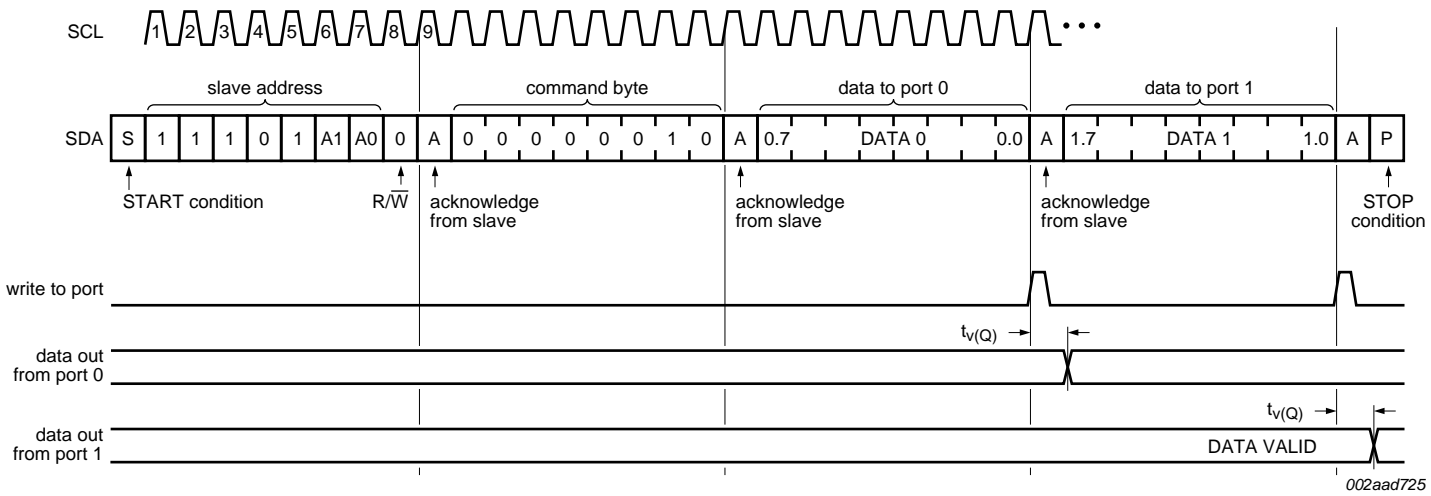

Fig 10. Write to output port registers

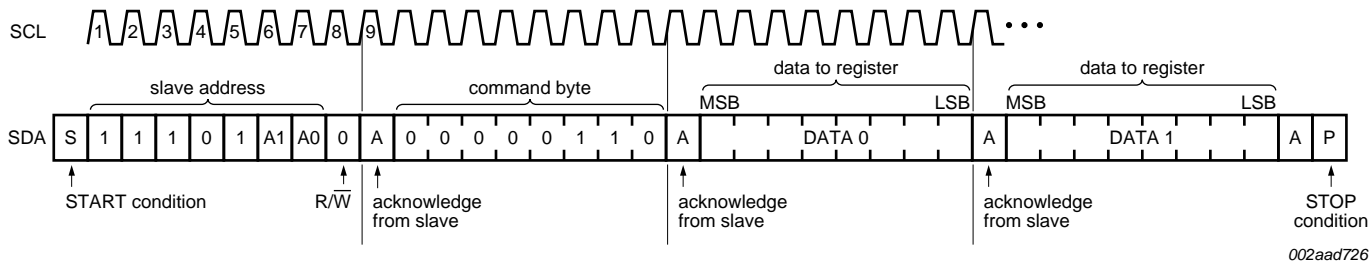
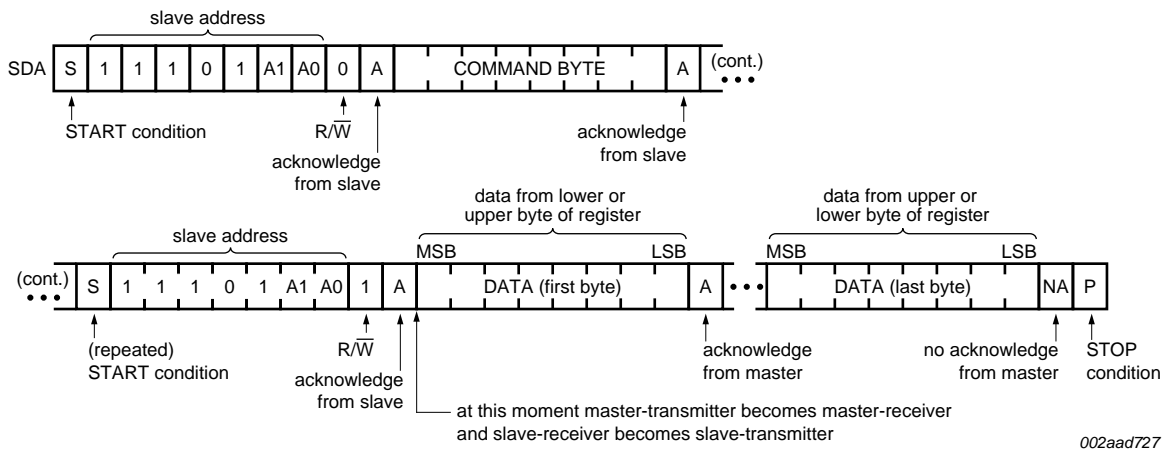

Fig 11. Write to configuration registers

6.6.2 Reading the port registers

In order to read data from the PCA9539; PCA9539R, the bus master must first send the PCA9539; PCA9539R address with the least significant bit set to a logic 0 (see [Figure 8 “PCA9539; PCA9539R device address”](#)). The command byte is sent after the address and determines which register will be accessed. After a restart, the device address is sent again, but this time the least significant bit is set to a logic 1. Data from the register defined by the command byte will then be sent by the PCA9539; PCA9539R (see [Figure 12](#), [Figure 13](#) and [Figure 14](#)). Data is clocked into the register on the falling edge of the acknowledge clock pulse. After the first byte is read, additional bytes may be read but the data will now reflect the information in the other register in the pair. For example, if you read Input port 1, then the next byte read would be Input port 0. There is no limitation on the number of data bytes received in one read transmission but the final byte received, the bus master must not acknowledge the data.



Remark: Transfer can be stopped at any time by a STOP condition.

Fig 12. Read from register

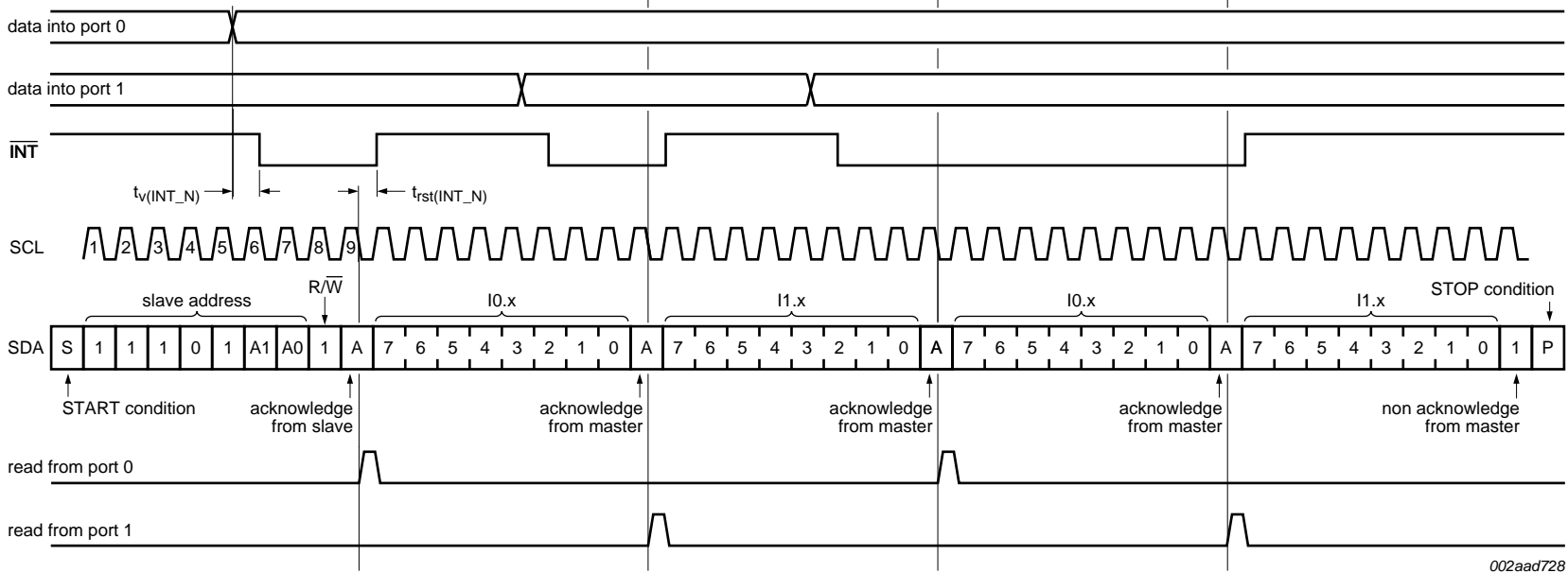

002aad728

Remark: Transfer of data can be stopped at any moment by a STOP condition. When this occurs, data present at the latest acknowledge phase is valid (output mode). It is assumed that the command byte has previously been set to '00' (read input port register).

Fig 13. Read input port register, scenario 1

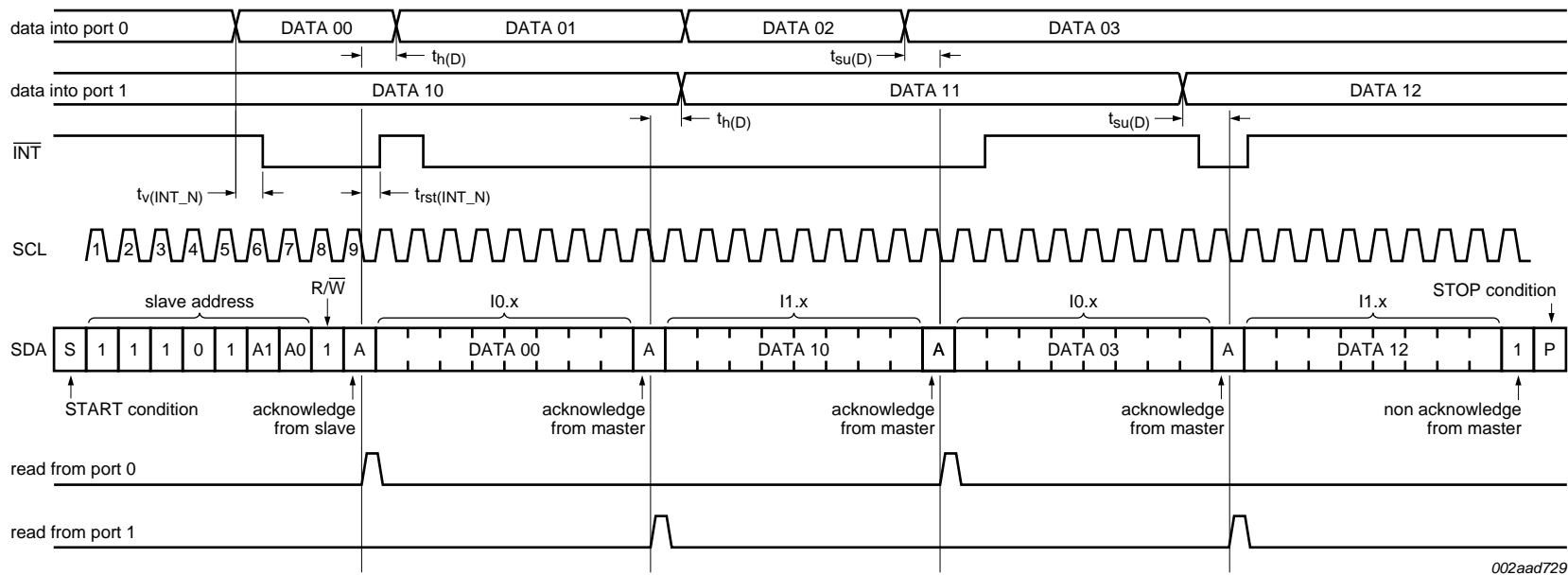

Remark: Transfer of data can be stopped at any moment by a STOP condition. When this occurs, data present at the latest acknowledge phase is valid (output mode). It is assumed that the command byte has previously been set to '00' (read input port register).

Fig 14. Read input port register, scenario 2

6.6.3 Interrupt output

The open-drain interrupt output is activated when one of the port pins changes state and the pin is configured as an input. The interrupt is deactivated when the input returns to its previous state or the Input port register is read (see [Figure 13](#)). A pin configured as an output cannot cause an interrupt. Since each 8-bit port is read independently, the interrupt caused by Port 0 will not be cleared by a read of Port 1 or the other way around.

Remark: Changing an I/O from an output to an input may cause a false interrupt to occur if the state of the pin does not match the contents of the Input port register.

7. Characteristics of the I²C-bus

The I²C-bus is for 2-way, 2-line communication between different ICs or modules. The two lines are a serial data line (SDA) and a serial clock line (SCL). Both lines must be connected to a positive supply via a pull-up resistor when connected to the output stages of a device. Data transfer may be initiated only when the bus is not busy.

7.1 Bit transfer

One data bit is transferred during each clock pulse. The data on the SDA line must remain stable during the HIGH period of the clock pulse as changes in the data line at this time will be interpreted as control signals (see [Figure 15](#)).

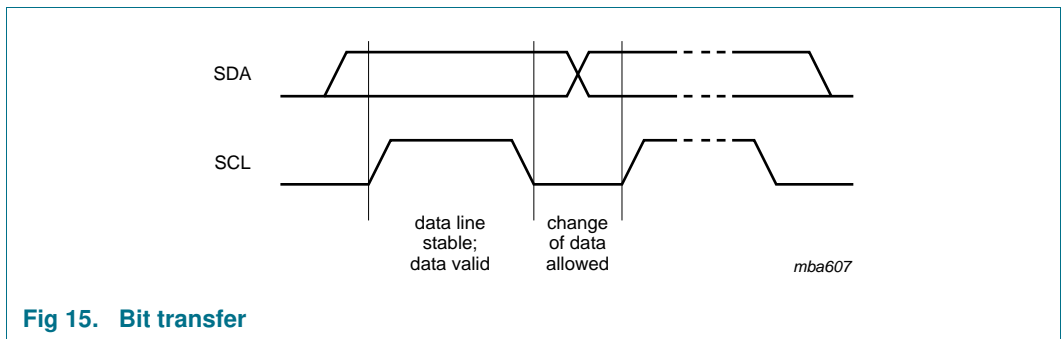

Fig 15. Bit transfer

7.1.1 START and STOP conditions

Both data and clock lines remain HIGH when the bus is not busy. A HIGH-to-LOW transition of the data line while the clock is HIGH is defined as the START condition (S). A LOW-to-HIGH transition of the data line while the clock is HIGH is defined as the STOP condition (P) (see [Figure 16](#)).

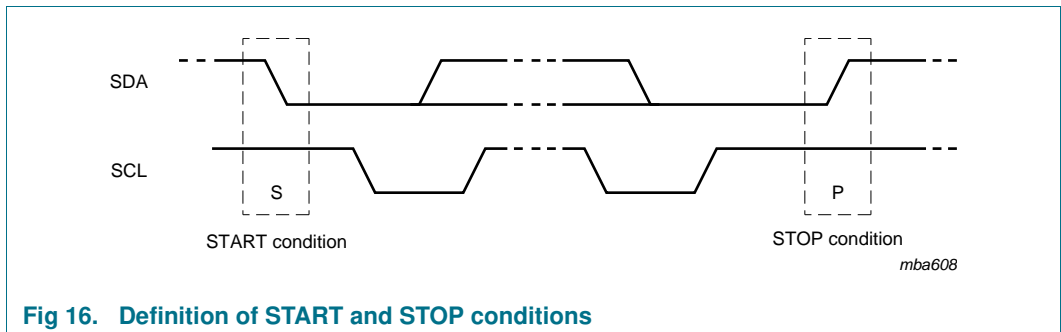

Fig 16. Definition of START and STOP conditions

7.2 System configuration

A device generating a message is a ‘transmitter’; a device receiving is the ‘receiver’. The device that controls the message is the ‘master’ and the devices which are controlled by the master are the ‘slaves’ (see [Figure 17](#)).

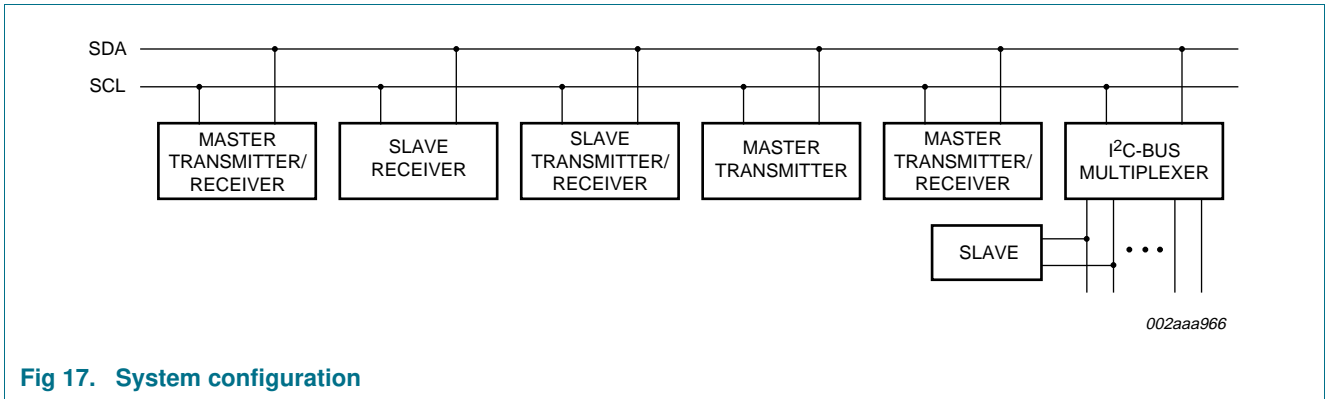

Fig 17. System configuration

7.3 Acknowledge

The number of data bytes transferred between the START and the STOP conditions from transmitter to receiver is not limited. Each byte of eight bits is followed by one acknowledge bit. The acknowledge bit is a HIGH level put on the bus by the transmitter, whereas the master generates an extra acknowledge related clock pulse.

A slave receiver which is addressed must generate an acknowledge after the reception of each byte. Also a master must generate an acknowledge after the reception of each byte that has been clocked out of the slave transmitter. The device that acknowledges has to pull down the SDA line during the acknowledge clock pulse, so that the SDA line is stable LOW during the HIGH period of the acknowledge related clock pulse; set-up time and hold time must be taken into account.

A master receiver must signal an end of data to the transmitter by not generating an acknowledge on the last byte that has been clocked out of the slave. In this event, the transmitter must leave the data line HIGH to enable the master to generate a STOP condition.

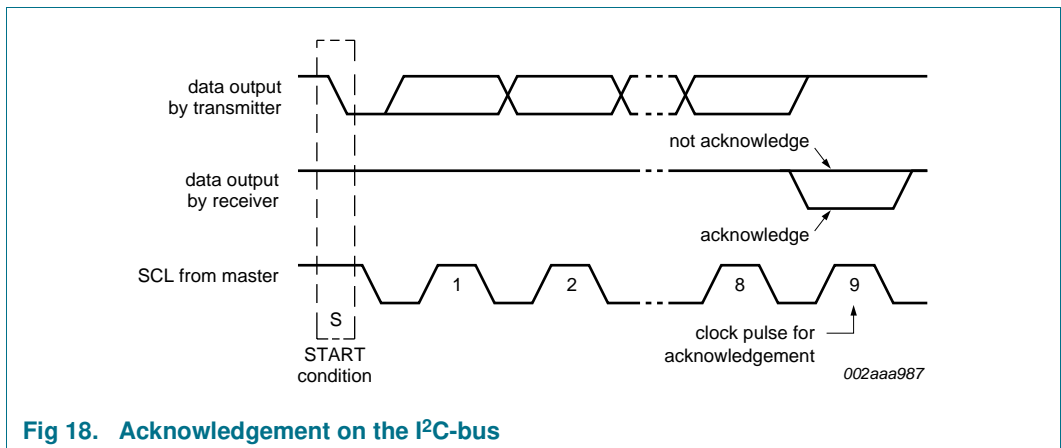
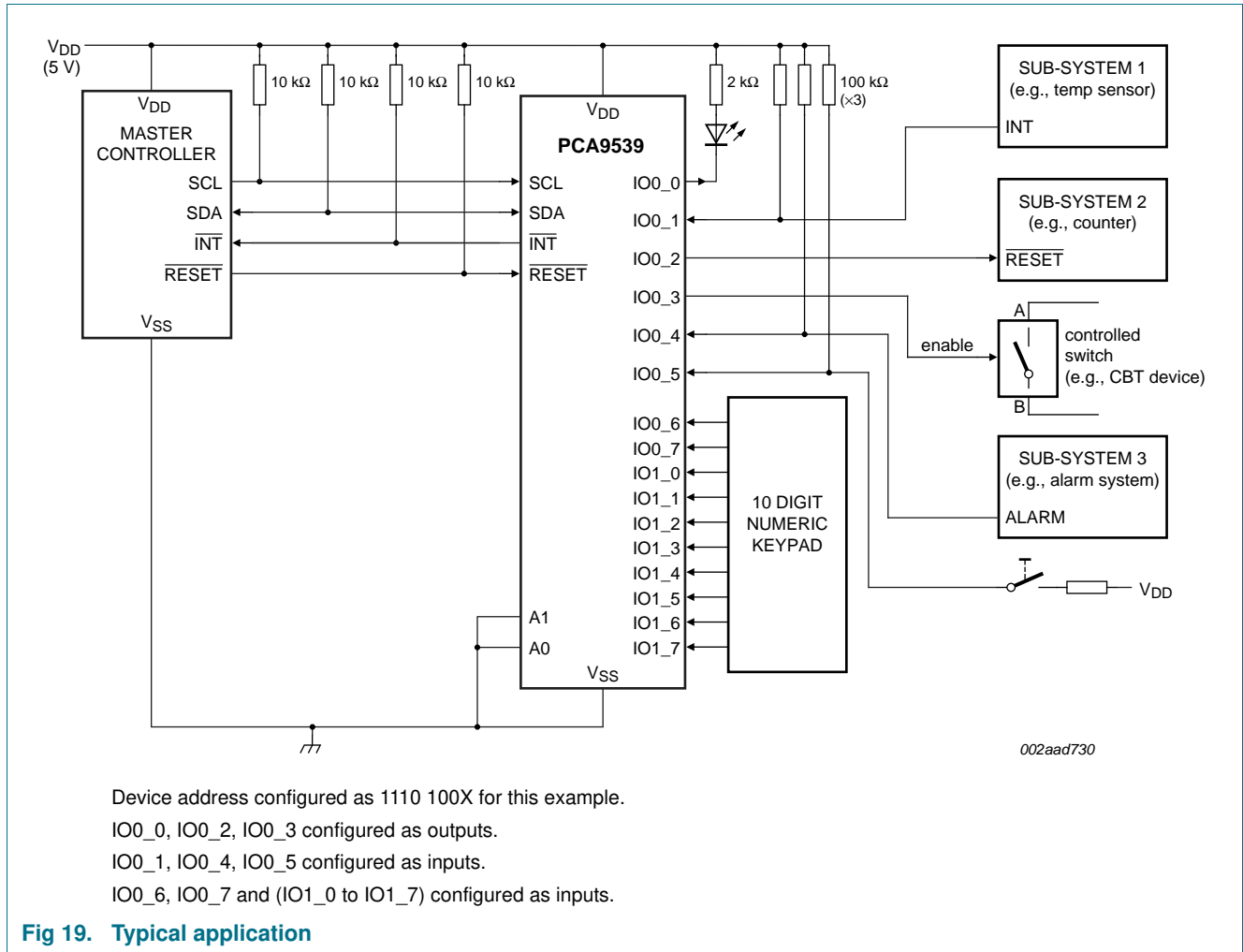

Fig 18. Acknowledgement on the I²C-bus

8. Application design-in information



8.1 Minimizing I_{DD} when the I/Os are used to control LEDs

When the I/Os are used to control LEDs, they are normally connected to V_{DD} through a resistor as shown in Figure 19. Since the LED acts as a diode, when the LED is off the I/O V_I is about 1.2 V less than V_{DD}. The supply current, I_{DD}, increases as V_I becomes lower than V_{DD}.

Designs needing to minimize current consumption, such as battery power applications, should consider maintaining the I/O pins greater than or equal to V_{DD} when the LED is off. Figure 20 shows a high value resistor in parallel with the LED. Figure 21 shows V_{DD} less than the LED supply voltage by at least 1.2 V. Both of these methods maintain the I/O V_I at or above V_{DD} and prevents additional supply current consumption when the LED is off.

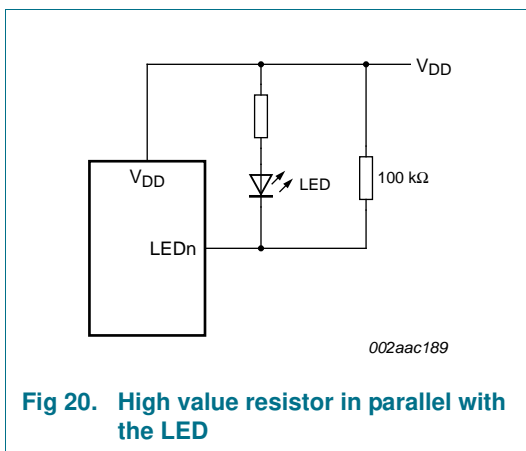

Fig 20. High value resistor in parallel with the LED

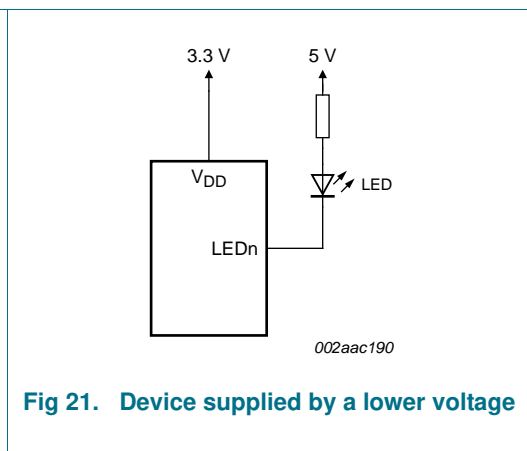

Fig 21. Device supplied by a lower voltage

9. Limiting values

Table 13. Limiting values

In accordance with the Absolute Maximum Rating System (IEC 60134).

Symbol	Parameter	Conditions	Min	Max	Unit
V _{DD}	supply voltage		-0.5	+6.0	V
V _{I/O}	voltage on an input/output pin		V _{SS} - 0.5	6	V
I _O	output current	on an I/O pin	-	±50	mA
I _I	input current		-	±20	mA
I _{DD}	supply current		-	160	mA
I _{SS}	ground supply current		-	200	mA
P _{tot}	total power dissipation		-	200	mW
T _{stg}	storage temperature		-65	+150	°C
T _{amb}	ambient temperature	operating			
		all devices except PCA9539PW/Q900 and PCA9539RPW/Q900	-40	+85	°C
		PCA9539PW/Q900 and PCA9539RPW/Q900	-40	+125	°C
T _{j(max)}	maximum junction temperature		-	125	°C

10. Static characteristics

Table 14. Static characteristics for all devices except PCA9539PW/Q900 and PCA9539RPW/Q900
 $V_{DD} = 2.3 \text{ V to } 5.5 \text{ V}; V_{SS} = 0 \text{ V}; T_{amb} = -40 \text{ }^{\circ}\text{C to } +85 \text{ }^{\circ}\text{C};$ unless otherwise specified.

Symbol	Parameter	Conditions	Min	Typ	Max	Unit
Supplies						
V_{DD}	supply voltage		2.3	-	5.5	V
I_{DD}	supply current	Operating mode; $V_{DD} = 5.5 \text{ V}$; no load; $f_{SCL} = 100 \text{ kHz}$; I/O = inputs	-	135	200	μA
I_{stb}	standby current	Standby mode; $V_{DD} = 5.5 \text{ V}$; no load; $V_I = V_{SS}$; $f_{SCL} = 0 \text{ kHz}$; I/O = inputs	-	0.25	1	μA
		Standby mode; $V_{DD} = 5.5 \text{ V}$; no load; $V_I = V_{DD}$; $f_{SCL} = 0 \text{ kHz}$; I/O = inputs	-	0.25	1	μA
V_{POR}	power-on reset voltage ^[1]	no load; $V_I = V_{DD}$ or V_{SS}	-	1.7	2.2	V
Input SCL; input/output SDA						
V_{IL}	LOW-level input voltage		-0.5	-	+0.3 V_{DD}	V
V_{IH}	HIGH-level input voltage		0.7 V_{DD}	-	5.5	V
I_{OL}	LOW-level output current	$V_{OL} = 0.4 \text{ V}$	3	-	-	mA
I_L	leakage current	$V_I = V_{DD} = V_{SS}$	-1	-	+1	μA
C_i	input capacitance	$V_I = V_{SS}$	-	6	10	pF
I/Os						
V_{IL}	LOW-level input voltage		-0.5	-	+0.3 V_{DD}	V
V_{IH}	HIGH-level input voltage		0.7 V_{DD}	-	5.5	V
I_{OL}	LOW-level output current	$V_{DD} = 2.3 \text{ V to } 5.5 \text{ V}; V_{OL} = 0.5 \text{ V}$ ^[2]	8	9	-	mA
		$V_{DD} = 2.3 \text{ V to } 5.5 \text{ V}; V_{OL} = 0.7 \text{ V}$ ^[2]	10	11	-	mA
V_{OH}	HIGH-level output voltage	$I_{OH} = -8 \text{ mA}; V_{DD} = 2.3 \text{ V}$ ^[3]	1.8	-	-	V
		$I_{OH} = -10 \text{ mA}; V_{DD} = 2.3 \text{ V}$ ^[3]	1.7	-	-	V
		$I_{OH} = -8 \text{ mA}; V_{DD} = 3.0 \text{ V}$ ^[3]	2.6	-	-	V
		$I_{OH} = -10 \text{ mA}; V_{DD} = 3.0 \text{ V}$ ^[3]	2.5	-	-	V
		$I_{OH} = -8 \text{ mA}; V_{DD} = 4.75 \text{ V}$ ^[3]	4.1	-	-	V
		$I_{OH} = -10 \text{ mA}; V_{DD} = 4.75 \text{ V}$ ^[3]	4.0	-	-	V
$I_{L IH}$	HIGH-level input leakage current	$V_{DD} = 5.5 \text{ V}; V_I = V_{DD}$	-	-	1	μA
$I_{L IL}$	LOW-level input leakage current	$V_{DD} = 5.5 \text{ V}; V_I = V_{SS}$	-	-	-1	μA
C_i	input capacitance		-	3.7	5	pF
C_o	output capacitance		-	3.7	5	pF
Interrupt INT						
I_{OL}	LOW-level output current	$V_{OL} = 0.4 \text{ V}$	3	-	-	mA
Select inputs A0, A1 and RESET						
V_{IL}	LOW-level input voltage		-0.5	-	+0.3 V_{DD}	V
V_{IH}	HIGH-level input voltage		0.7 V_{DD}	-	5.5	V
I_{LI}	input leakage current		-1	-	+1	μA

[1] V_{DD} must be lowered to 0.2 V for at least 5 μs in order to reset part.

[2] Each I/O must be externally limited to a maximum of 25 mA and each octal (IO0_0 to IO0_7 and IO1_0 to IO1_7) must be limited to a maximum current of 100 mA for a device total of 200 mA.

[3] The total current sourced by all I/Os must be limited to 160 mA (80 mA for IO0_0 through IO0_7 and 80 mA for IO1_0 through IO1_7).

Table 15. Static characteristics for PCA9539PW/Q900 and PCA9539RPW/Q900
V_{DD} = 3.0 V to 5.5 V; V_{SS} = 0 V; T_{amb} = -40 °C to +125 °C; unless otherwise specified.

Symbol	Parameter	Conditions	Min	Typ	Max	Unit
Supplies						
V _{DD}	supply voltage		3.0	-	5.5	V
I _{DD}	supply current	Operating mode; V _{DD} = 5.5 V; no load; f _{SCL} = 100 kHz; I/O = inputs	-	135	200	μA
I _{stb}	standby current	Standby mode; V _{DD} = 5.5 V; no load; V _I = V _{SS} ; f _{SCL} = 0 kHz; I/O = inputs	-	0.25	1	μA
		Standby mode; V _{DD} = 5.5 V; no load; V _I = V _{DD} ; f _{SCL} = 0 kHz; I/O = inputs	-	0.25	1	μA
V _{POR}	power-on reset voltage ^[1]	no load; V _I = V _{DD} or V _{SS}	-	1.7	2.2	V
Input SCL; input/output SDA						
V _{IL}	LOW-level input voltage		-0.5	-	+0.3V _{DD}	V
V _{IH}	HIGH-level input voltage		0.7V _{DD}	-	5.5	V
I _{OL}	LOW-level output current, SDA	V _{OL} = 0.4 V				
		V _{DD} = 5.5 V	3	-	-	mA
		V _{DD} = 3.0 V	2.5	-	-	mA
I _L	leakage current	V _I = V _{DD} = V _{SS}	-1	-	+1	μA
C _i	input capacitance	V _I = V _{SS}	-	6	10	pF
I/Os						
V _{IL}	LOW-level input voltage		-0.5	-	+0.3V _{DD}	V
V _{IH}	HIGH-level input voltage		0.7V _{DD}	-	5.5	V
I _{OL}	LOW-level output current	V _{OL} = 0.5 V				
		V _{DD} = 4.5 V	^[2] 8	9	-	mA
		V _{DD} = 3.0 V	^[2] 7.5	-	-	mA
		V _{OL} = 0.7 V				
		V _{DD} = 4.5 V	^[2] 10	11	-	mA
		V _{DD} = 3.0 V	^[2] 9.5	-	-	mA
V _{OH}	HIGH-level output voltage	I _{OH} = -8 mA				
		V _{DD} = 4.5 V	^[3] 4.1	-	-	V
		V _{DD} = 3.0 V	^[3] 2.5	-	-	V
		I _{OH} = -10 mA				
		V _{DD} = 4.5 V	^[3] 4.0	-	-	V
		V _{DD} = 3.0 V	^[3] 2.4	-	-	V
I _{LIH}	HIGH-level input leakage current	V _{DD} = 5.5 V; V _I = V _{DD}	-	-	1	μA
I _{LIL}	LOW-level input leakage current	V _{DD} = 5.5 V; V _I = V _{SS}	-	-	-1	μA
C _i	input capacitance		-	3.7	5	pF
C _o	output capacitance		-	3.7	5	pF
Interrupt INT						
I _{OL}	LOW-level output current	V _{OL} = 0.4 V	3	-	-	mA

Table 15. Static characteristics for PCA9539PW/Q900 and PCA9539RPW/Q900 ...continued
 $V_{DD} = 3.0\text{ V to }5.5\text{ V}$; $V_{SS} = 0\text{ V}$; $T_{amb} = -40\text{ }^{\circ}\text{C to }+125\text{ }^{\circ}\text{C}$; unless otherwise specified.

Symbol	Parameter	Conditions	Min	Typ	Max	Unit
Select inputs A0, A1 and RESET						
V _{IL}	LOW-level input voltage		-0.5	-	+0.3V _{DD}	V
V _{IH}	HIGH-level input voltage		0.7V _{DD}	-	5.5	V
I _{LI}	input leakage current		-1	-	+1	μA

- [1] V_{DD} must be lowered to 0.2 V for at least 5 μs in order to reset part.
- [2] Each I/O must be externally limited to a maximum of 25 mA and each octal (IO0_0 to IO0_7 and IO1_0 to IO1_7) must be limited to a maximum current of 100 mA for a device total of 200 mA.
- [3] The total current sourced by all I/Os must be limited to 160 mA (80 mA for IO0_0 through IO0_7 and 80 mA for IO1_0 through IO1_7).

11. Dynamic characteristics

Table 16. Dynamic characteristics

Symbol	Parameter	Conditions	Standard-mode I ² C-bus		Fast-mode I ² C-bus		Unit
			Min	Max	Min	Max	
f _{SCL}	SCL clock frequency		0	100	0	400	kHz
t _{BUF}	bus free time between a STOP and START condition		4.7	-	1.3	-	μs
t _{HD;STA}	hold time (repeated) START condition		4.0	-	0.6	-	μs
t _{SU;STA}	set-up time for a repeated START condition		4.7	-	0.6	-	μs
t _{SU;STO}	set-up time for STOP condition		4.0	-	0.6	-	μs
t _{VD;ACK}	data valid acknowledge time	[1]	0.3	3.45	0.1	0.9	μs
t _{HD;DAT}	data hold time		0	-	0	-	ns
t _{VD;DAT}	data valid time	[2]	300	-	50	-	ns
t _{SU;DAT}	data set-up time		250	-	100	-	ns
t _{LOW}	LOW period of the SCL clock		4.7	-	1.3	-	μs
t _{HIGH}	HIGH period of the SCL clock		4.0	-	0.6	-	μs
t _f	fall time of both SDA and SCL signals	[3]	-	300	20 + 0.1C _b	300	ns
t _r	rise time of both SDA and SCL signals	[3]	-	1000	20 + 0.1C _b	300	ns
t _{SP}	pulse width of spikes that must be suppressed by the input filter		-	50	-	50	ns
Port timing							
t _{v(Q)}	data output valid time	[4]	-	200	-	200	ns
t _{su(D)}	data input set-up time		150	-	150	-	ns
t _{h(D)}	data input hold time		1	-	1	-	μs

Table 16. Dynamic characteristics ...continued

Symbol	Parameter	Conditions	Standard-mode I ² C-bus		Fast-mode I ² C-bus		Unit
			Min	Max	Min	Max	
Interrupt timing							
t _{v(INT_N)}	valid time on pin $\overline{\text{INT}}$		-	4	-	4	μs
t _{rst(INT_N)}	reset time on pin $\overline{\text{INT}}$		-	4	-	4	μs
RESET timing							
t _{w(rst)}	reset pulse width	all devices except PCA9539RPW/Q900	4	-	4	-	ns
		PCA9539RPW/Q900	6	-	6	-	ns
t _{rec(rst)}	reset recovery time		0	-	0	-	ns
t _{rst}	reset time	[5][6]	400	-	400	-	ns

- [1] t_{VD;ACK} = time for acknowledgement signal from SCL LOW to SDA (out) LOW.
- [2] t_{VD;DAT} = minimum time for SDA data out to be valid following SCL LOW.
- [3] C_b = total capacitance of one bus line in pF.
- [4] t_{v(Q)} measured from 0.7V_{DD} on SCL to 50 % I/O output.
- [5] Resetting the device while actively communicating on the bus may cause glitches or errant STOP conditions.
- [6] Upon reset, the full delay will be the sum of t_{rst} and the RC time constant of the SDA bus.

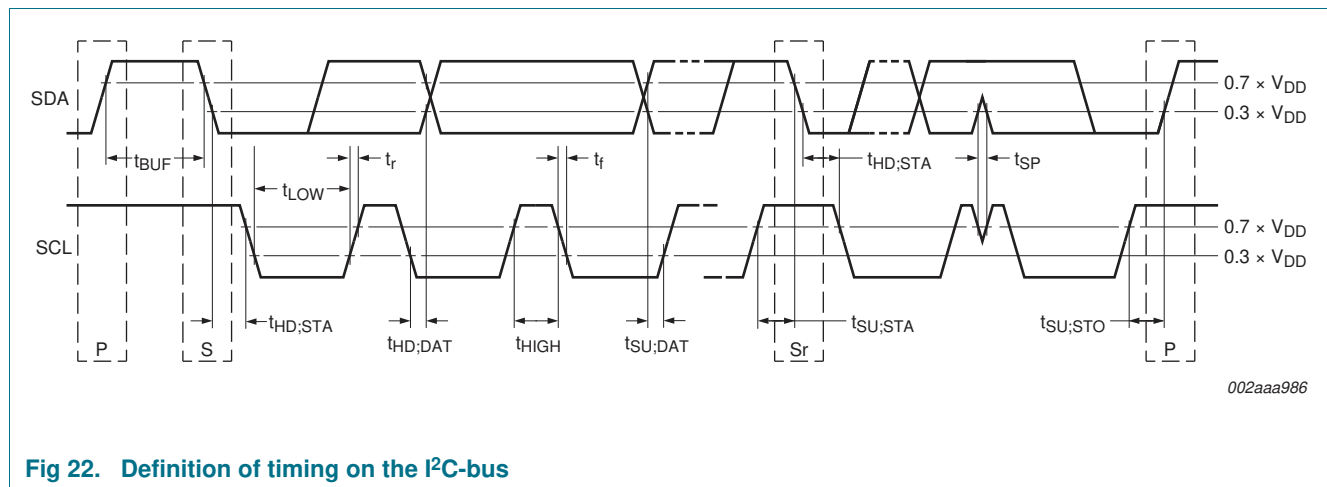
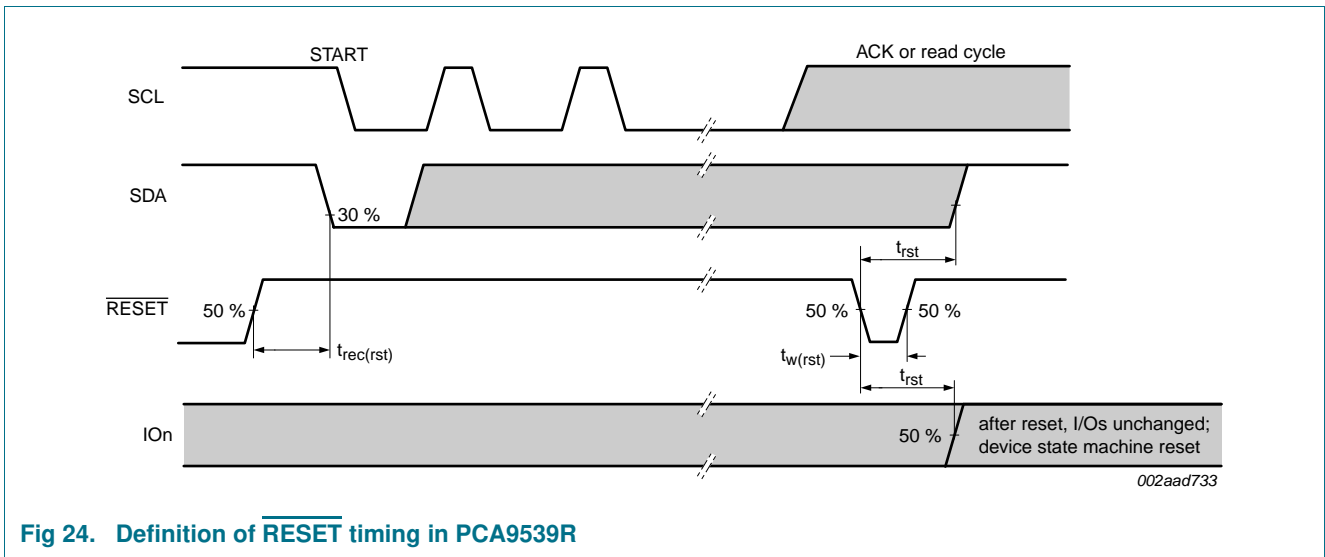
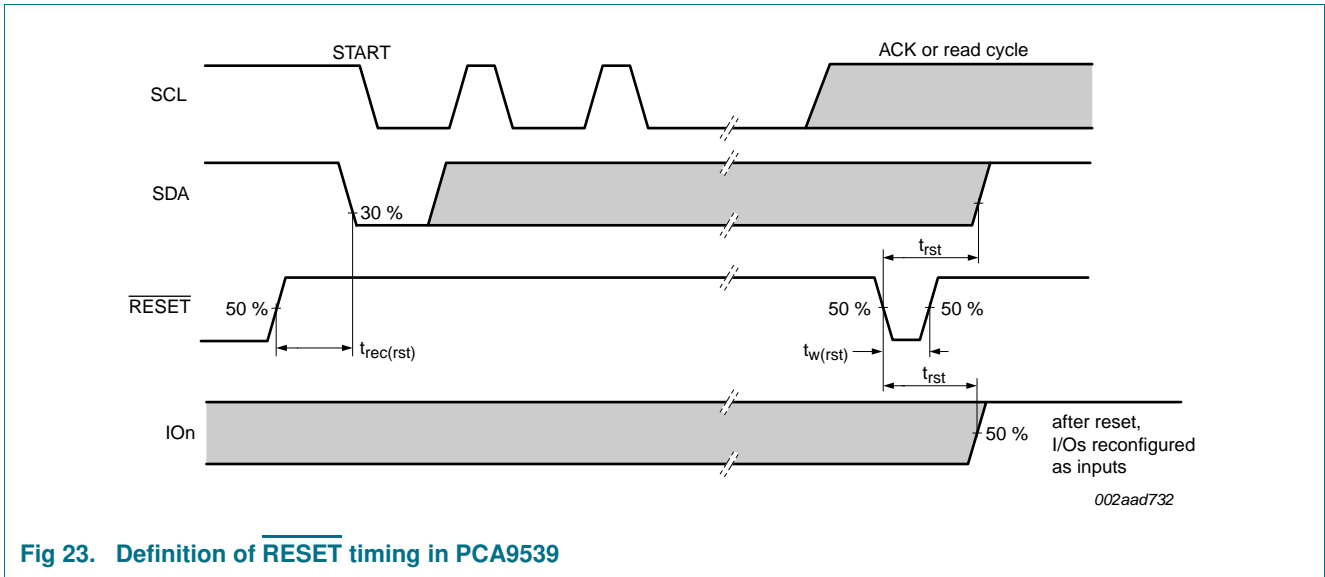

Fig 22. Definition of timing on the I²C-bus



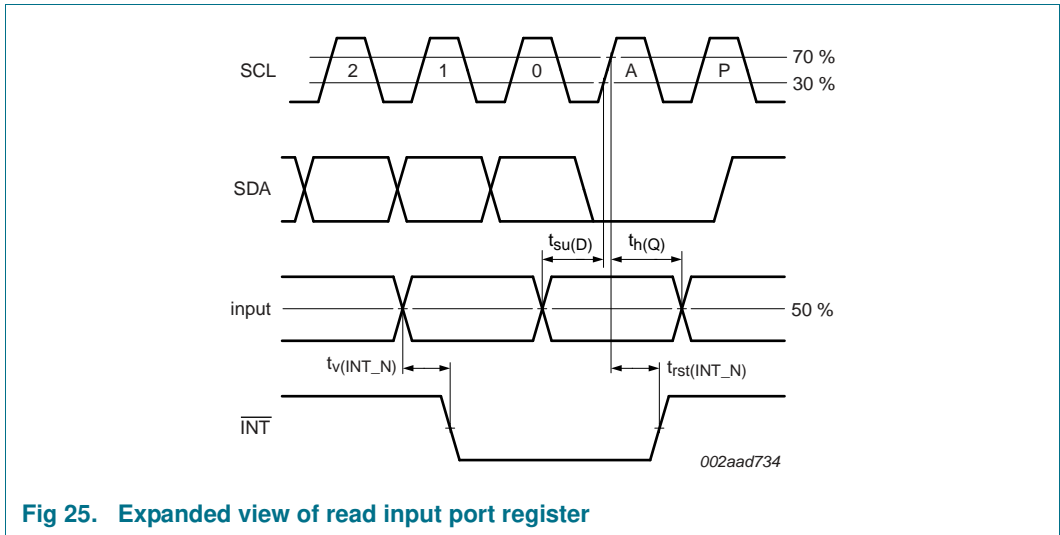

Fig 25. Expanded view of read input port register

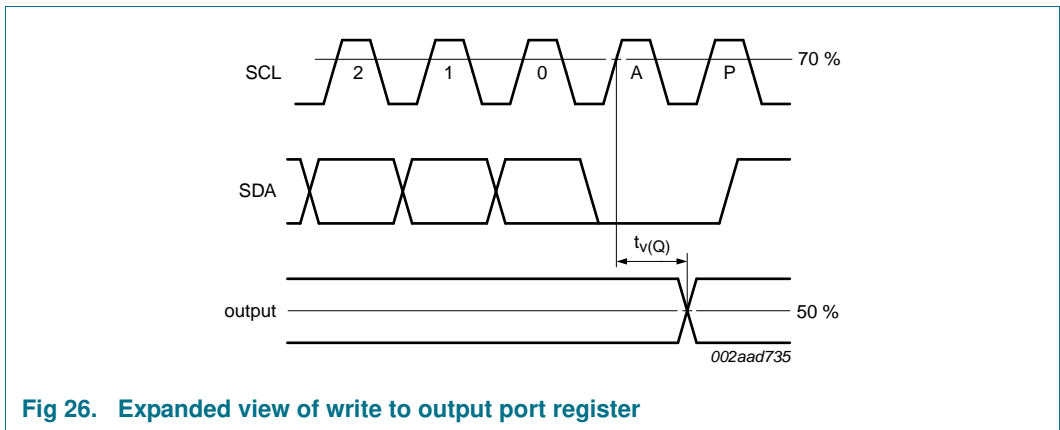

Fig 26. Expanded view of write to output port register

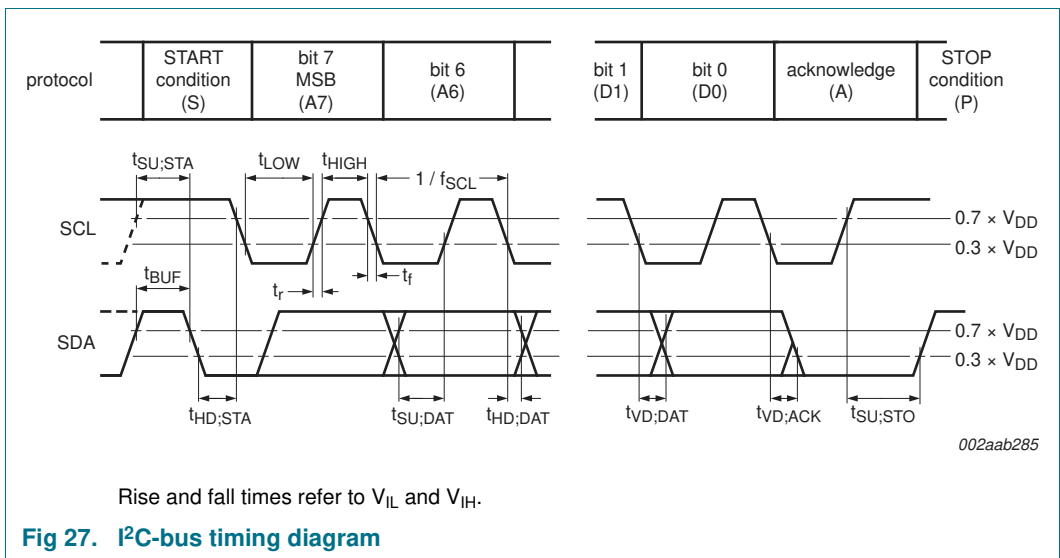

Fig 27. I²C-bus timing diagram

12. Test information

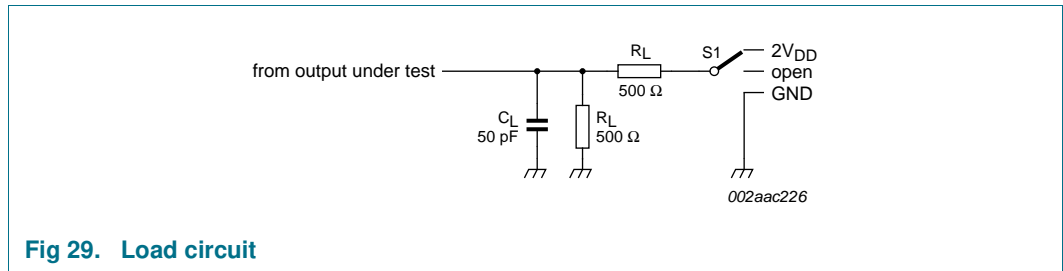
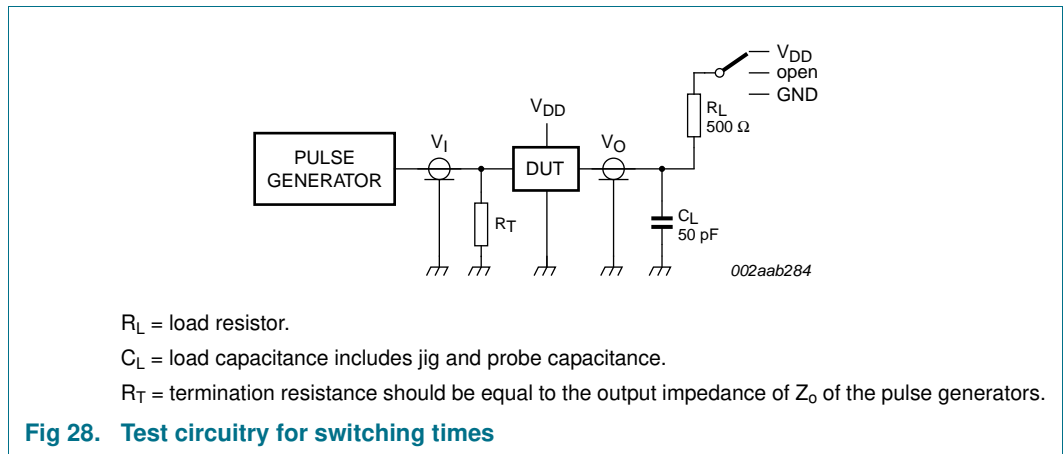

Table 17. Test data

Test	Load		Switch
	C_L	R_L	
$t_{V(Q)}$	50 pF	500 Ω	$2 \times V_{DD}$

13. Package outline

SO24: plastic small outline package; 24 leads; body width 7.5 mm

SOT137-1

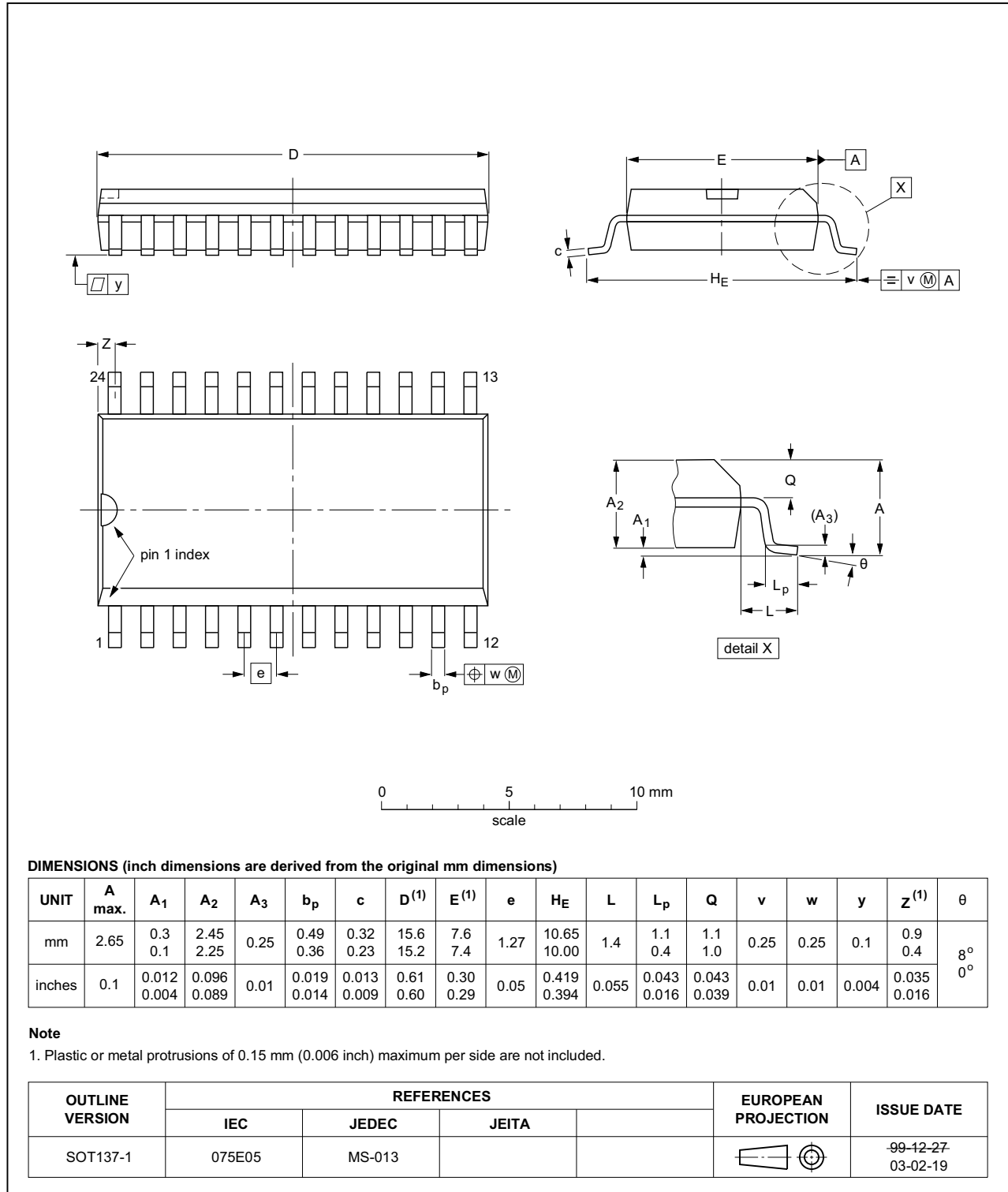

Fig 30. Package outline SOT137-1 (SO24)

TSSOP24: plastic thin shrink small outline package; 24 leads; body width 4.4 mm

SOT355-1

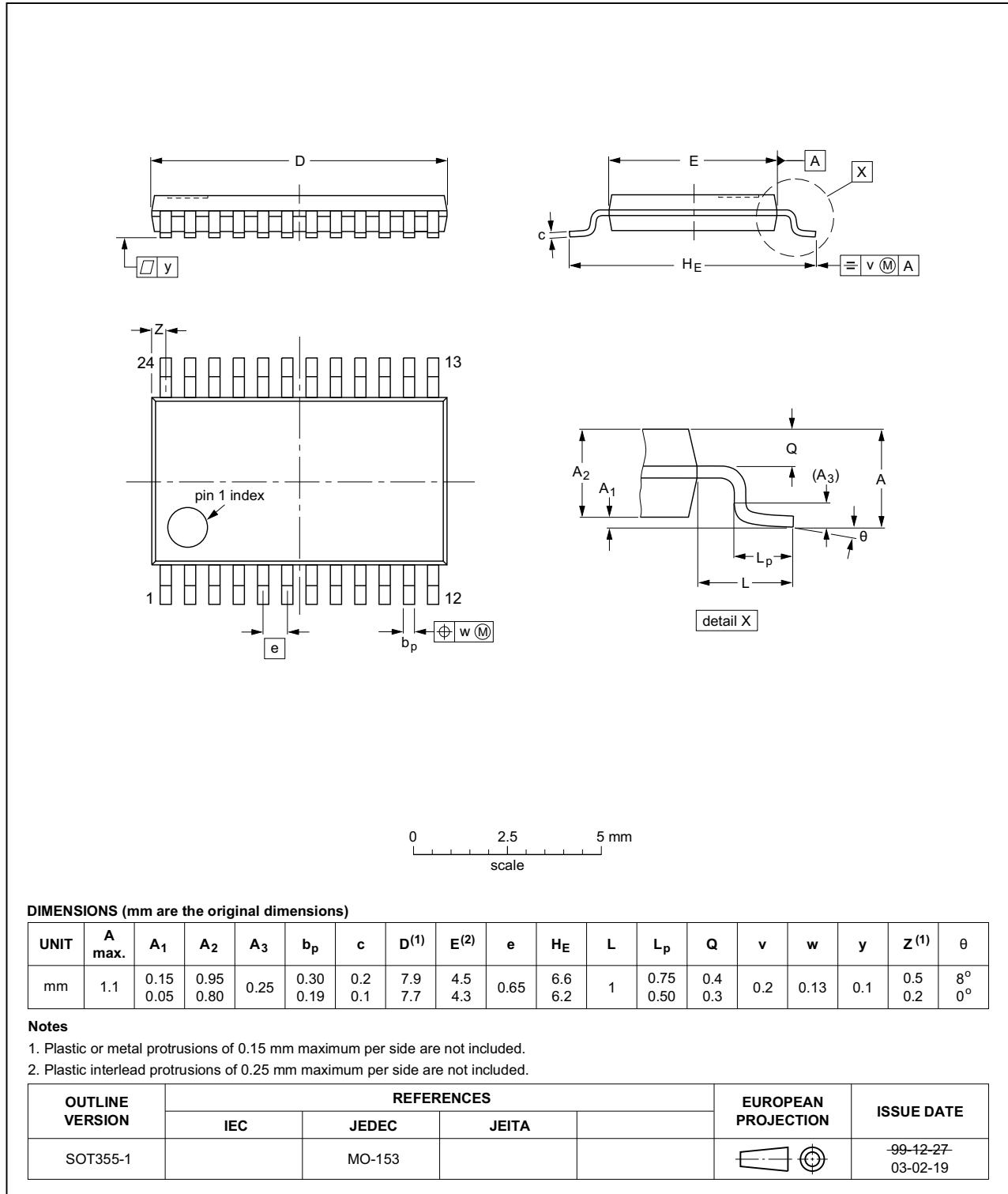

Fig 31. Package outline SOT355-1 (TSSOP24)

HVQFN24: plastic thermal enhanced very thin quad flat package; no leads;
24 terminals; body 4 x 4 x 0.85 mm

SOT616-1

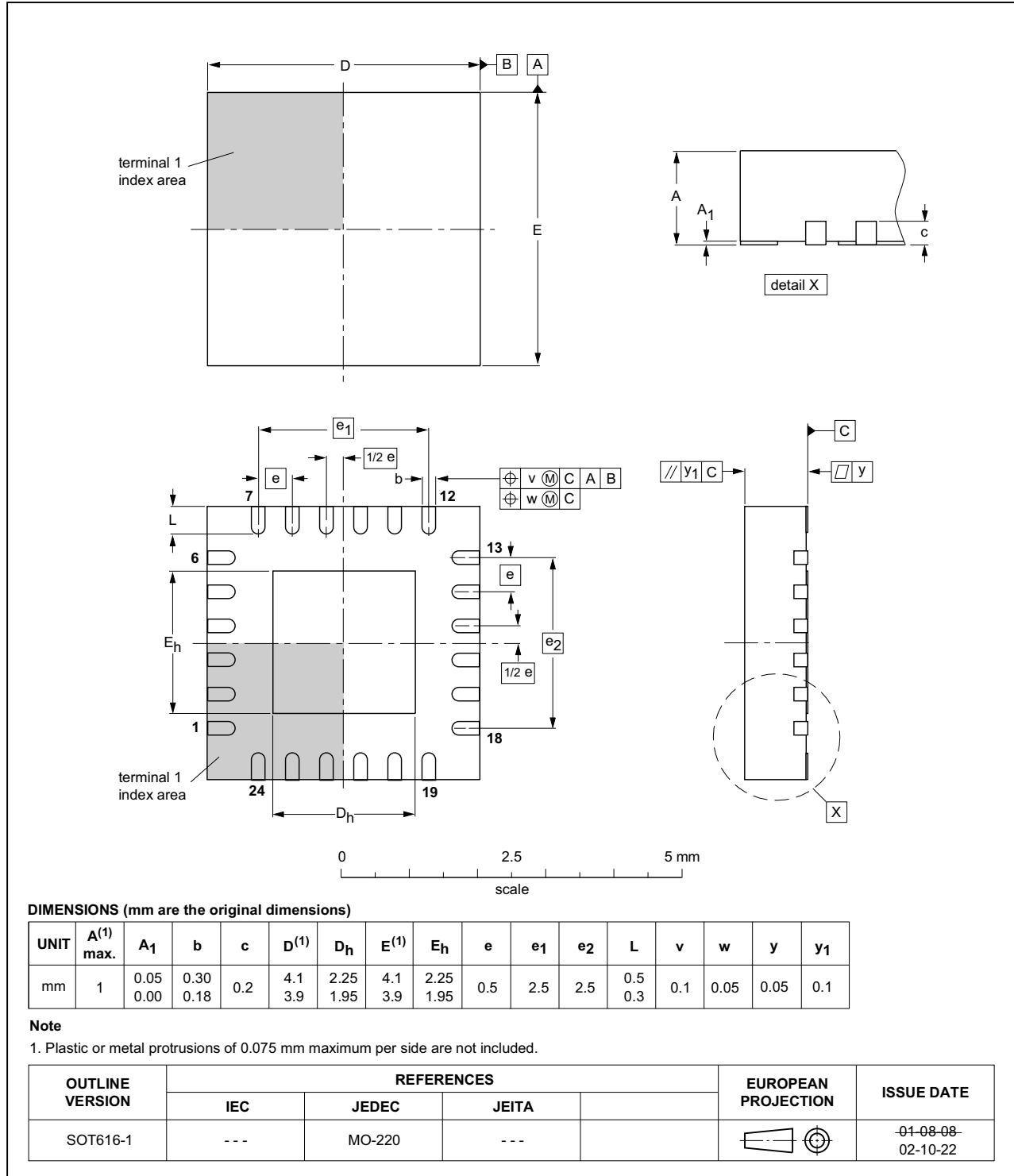

Fig 32. Package outline SOT616-1 (HVQFN24)

14. Handling information

All input and output pins are protected against ElectroStatic Discharge (ESD) under normal handling. When handling ensure that the appropriate precautions are taken as described in *JESD625-A* or equivalent standards.

15. Soldering of SMD packages

This text provides a very brief insight into a complex technology. A more in-depth account of soldering ICs can be found in Application Note *AN10365 "Surface mount reflow soldering description"*.

15.1 Introduction to soldering

Soldering is one of the most common methods through which packages are attached to Printed Circuit Boards (PCBs), to form electrical circuits. The soldered joint provides both the mechanical and the electrical connection. There is no single soldering method that is ideal for all IC packages. Wave soldering is often preferred when through-hole and Surface Mount Devices (SMDs) are mixed on one printed wiring board; however, it is not suitable for fine pitch SMDs. Reflow soldering is ideal for the small pitches and high densities that come with increased miniaturization.

15.2 Wave and reflow soldering

Wave soldering is a joining technology in which the joints are made by solder coming from a standing wave of liquid solder. The wave soldering process is suitable for the following:

- Through-hole components
- Leaded or leadless SMDs, which are glued to the surface of the printed circuit board

Not all SMDs can be wave soldered. Packages with solder balls, and some leadless packages which have solder lands underneath the body, cannot be wave soldered. Also, leaded SMDs with leads having a pitch smaller than ~0.6 mm cannot be wave soldered, due to an increased probability of bridging.

The reflow soldering process involves applying solder paste to a board, followed by component placement and exposure to a temperature profile. Leaded packages, packages with solder balls, and leadless packages are all reflow solderable.

Key characteristics in both wave and reflow soldering are:

- Board specifications, including the board finish, solder masks and vias
- Package footprints, including solder thieves and orientation
- The moisture sensitivity level of the packages
- Package placement
- Inspection and repair
- Lead-free soldering versus SnPb soldering

15.3 Wave soldering

Key characteristics in wave soldering are:

- Process issues, such as application of adhesive and flux, clinching of leads, board transport, the solder wave parameters, and the time during which components are exposed to the wave
- Solder bath specifications, including temperature and impurities

15.4 Reflow soldering

Key characteristics in reflow soldering are:

- Lead-free versus SnPb soldering; note that a lead-free reflow process usually leads to higher minimum peak temperatures (see [Figure 33](#)) than a SnPb process, thus reducing the process window
- Solder paste printing issues including smearing, release, and adjusting the process window for a mix of large and small components on one board
- Reflow temperature profile; this profile includes preheat, reflow (in which the board is heated to the peak temperature) and cooling down. It is imperative that the peak temperature is high enough for the solder to make reliable solder joints (a solder paste characteristic). In addition, the peak temperature must be low enough that the packages and/or boards are not damaged. The peak temperature of the package depends on package thickness and volume and is classified in accordance with [Table 18](#) and [19](#)

Table 18. SnPb eutectic process (from J-STD-020D)

Package thickness (mm)	Package reflow temperature (°C)	
	Volume (mm ³)	
	< 350	≥ 350
< 2.5	235	220
≥ 2.5	220	220

Table 19. Lead-free process (from J-STD-020D)

Package thickness (mm)	Package reflow temperature (°C)		
	Volume (mm ³)		
	< 350	350 to 2000	> 2000
< 1.6	260	260	260
1.6 to 2.5	260	250	245
> 2.5	250	245	245

Moisture sensitivity precautions, as indicated on the packing, must be respected at all times.

Studies have shown that small packages reach higher temperatures during reflow soldering, see [Figure 33](#).

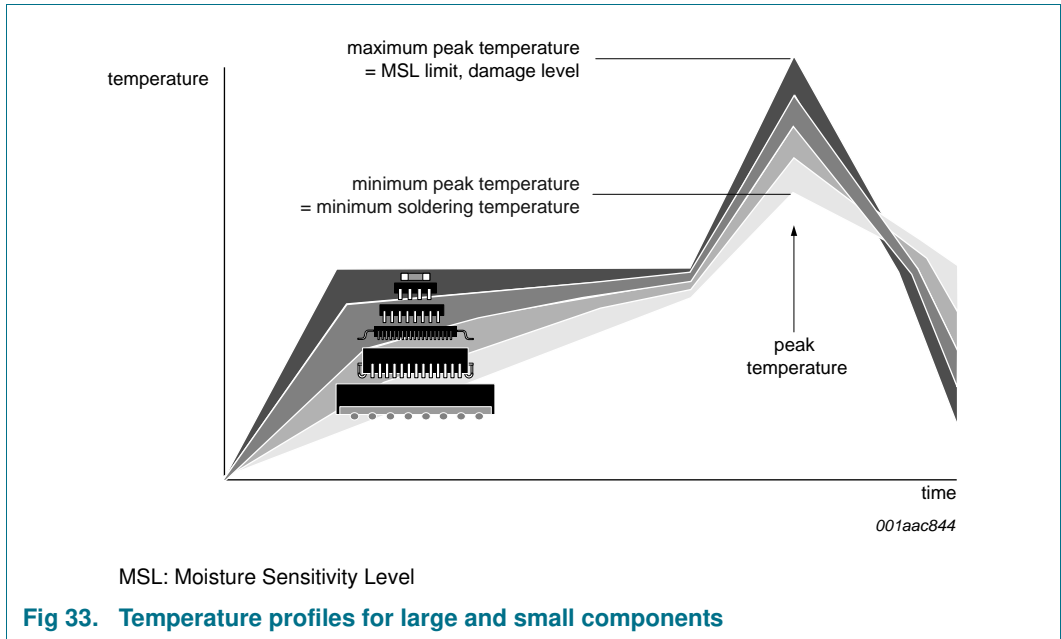

For further information on temperature profiles, refer to Application Note *AN10365* "Surface mount reflow soldering description".

16. Soldering: PCB footprints

Footprint information for reflow soldering of SO24 package

SOT137-1

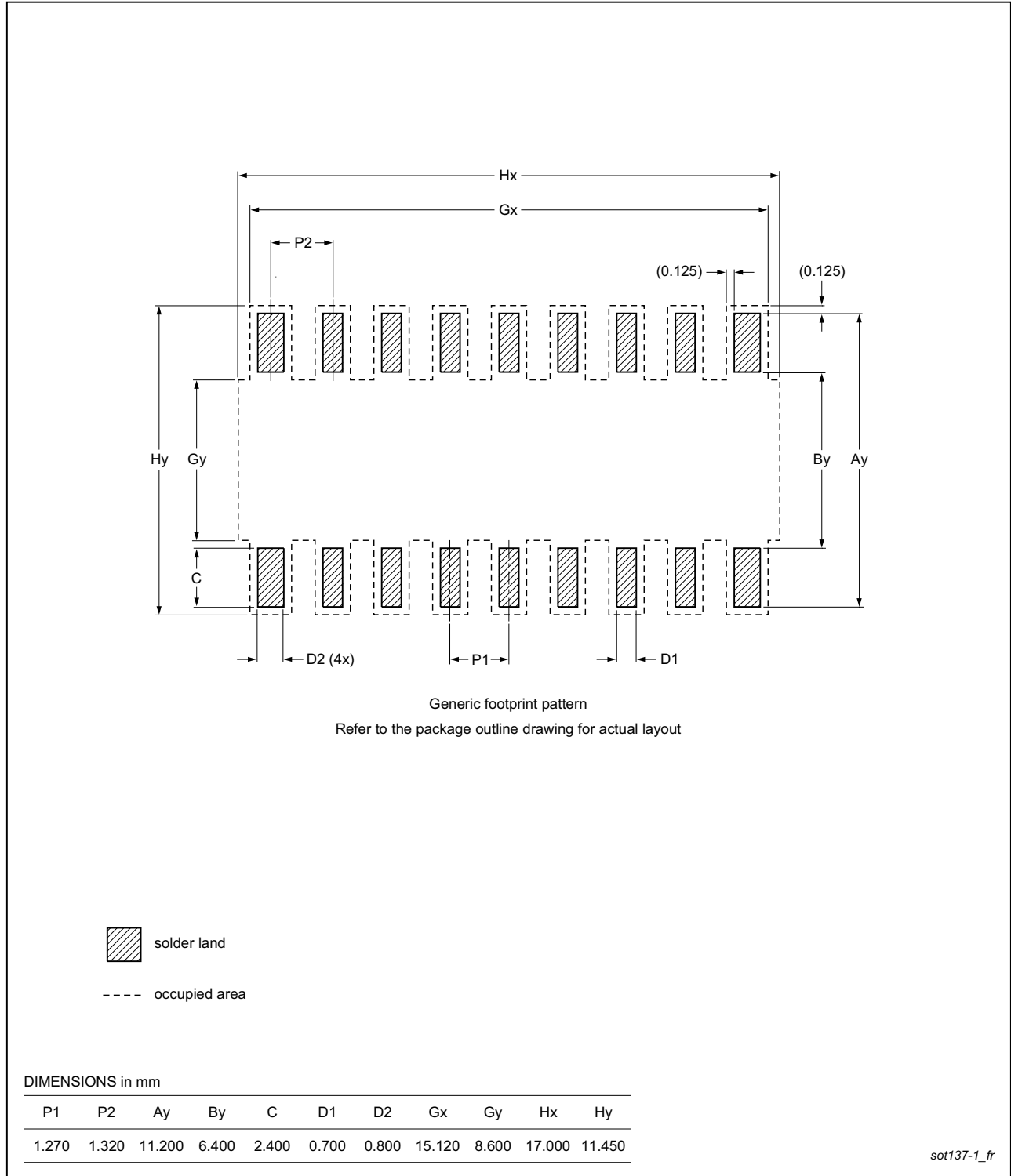

Fig 34. PCB footprint for SOT137-1 (SO24); reflow soldering

Footprint information for reflow soldering of TSSOP24 package

SOT355-1

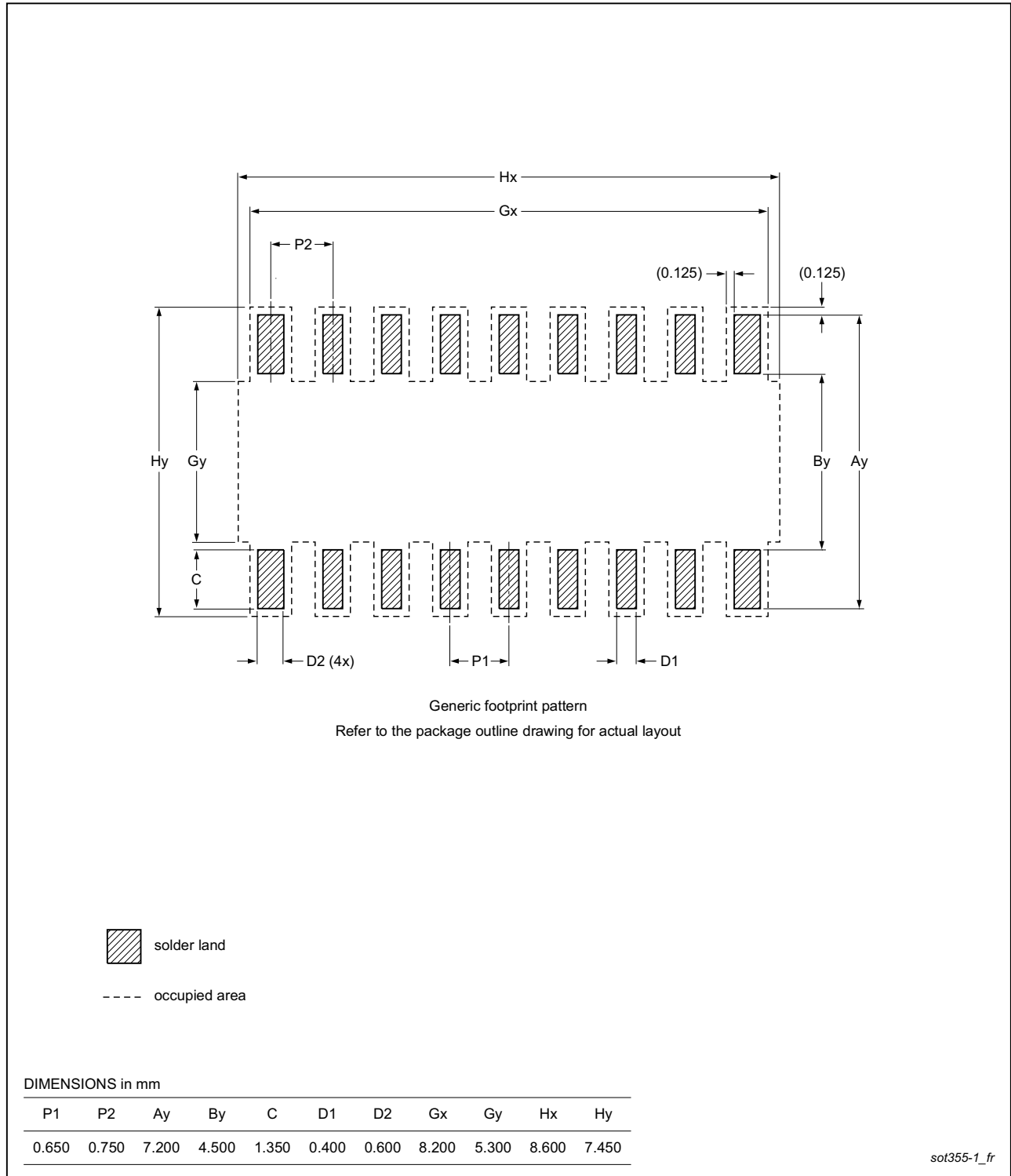

Fig 35. PCB footprint for SOT355-1 (TSSOP24); reflow soldering

Footprint information for reflow soldering of HVQFN24 package

SOT616-1

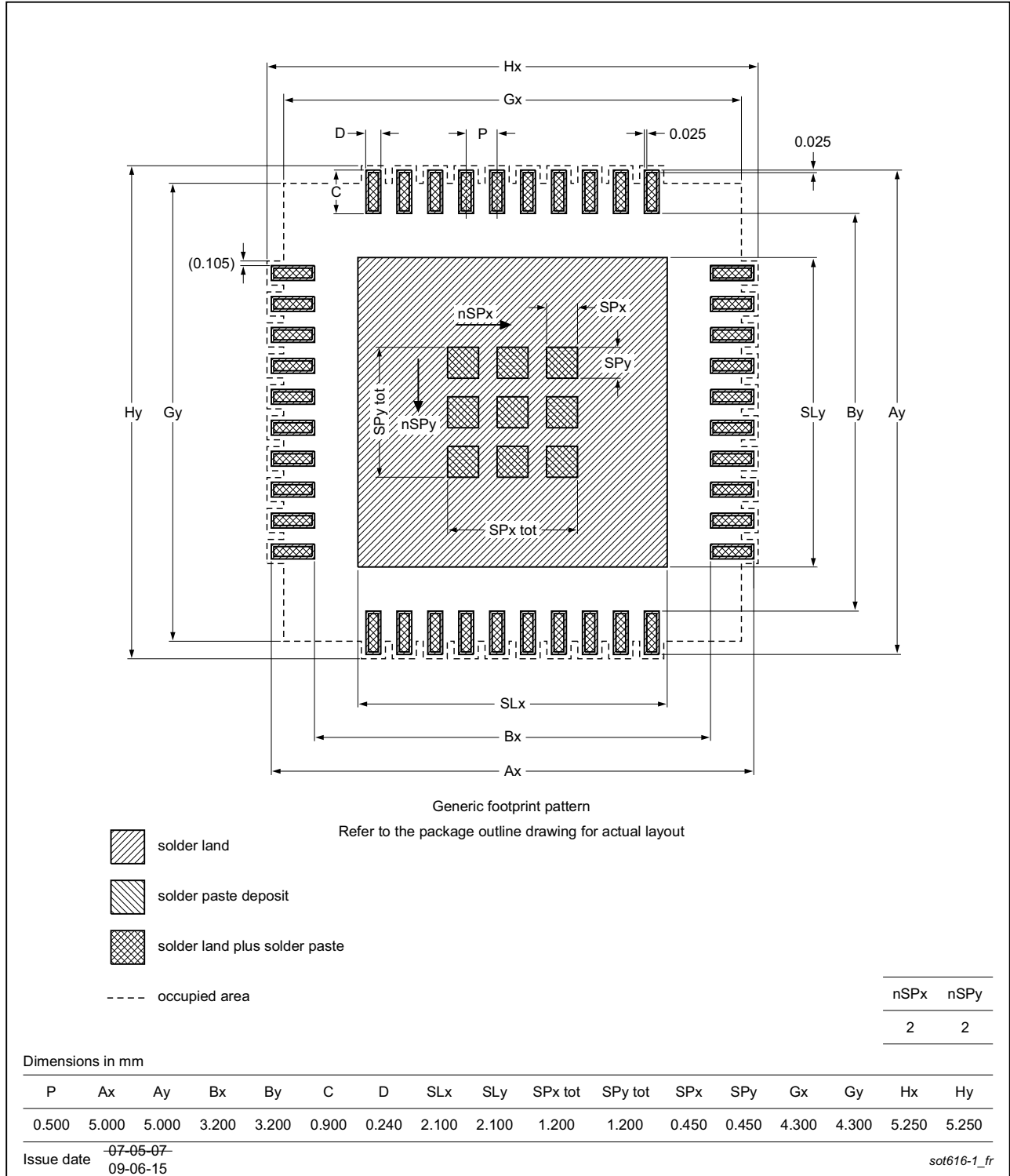

Fig 36. PCB footprint for SOT616-1 (HVQFN24); reflow soldering

17. Abbreviations

Table 20. Abbreviations

Acronym	Description
ACPI	Advanced Configuration and Power Interface
CBT	Cross-Bar Technology
CDM	Charged-Device Model
CMOS	Complementary Metal-Oxide Semiconductor
ESD	ElectroStatic Discharge
FET	Field-Effect Transistor
FF	Flip-Flop
GPIO	General Purpose Input/Output
HBM	Human Body Model
I ² C-bus	Inter-Integrated Circuit bus
I/O	Input/Output
LED	Light Emitting Diode
SMBus	System Management Bus

18. Revision history

Table 21. Revision history

Document ID	Release date	Data sheet status	Change notice	Supersedes
PCA9539_PCA9539R v.9	20171108	Product data sheet	201710002I	PCA9539_PCA9539R v.8.2
Modifications:	<ul style="list-style-type: none"> • Table 14 “Static characteristics for all devices except PCA9539PW/Q900 and PCA9539RPW/Q900”, Table 15 “Static characteristics for PCA9539PW/Q900 and PCA9539RPW/Q900”; : Corrected V_{POR} typ and max limit 			
PCA9539_PCA9539R v.8.2	20161123	Product data sheet	-	PCA9539_PCA9539R v.8.1
Modifications:	<ul style="list-style-type: none"> • Added PCA9539RPW/Q900 to Figure 6 “Pin configuration for TSSOP24” • Table 16 “Dynamic characteristics”, t_{w(rst)}: added AC parameters for PCA9539RPW/Q900 			
PCA9539_PCA9539R v.8.1	20161123	Product data sheet	-	PCA9539_PCA9539R v.8
Modifications:	<ul style="list-style-type: none"> • Added PCA9539RPW/Q900 			
PCA9539_PCA9539R v.8	20141126	Product data sheet	-	PCA9539_PCA9539R v.7
Modifications:	<ul style="list-style-type: none"> • Table 15 “Static characteristics for PCA9539PW/Q900 and PCA9539RPW/Q900”: updated I_{OL} and V_{OH}; changed operating power supply voltage range from “5.0 V ± 10 %” to “3.0 V to 5.5 V” for PCA9539PW/Q900 			
PCA9539_PCA9539R v.7	20140415	Product data sheet	-	PCA9539_PCA9539R v.6
PCA9539_PCA9539R v.6	20130206	Product data sheet	-	PCA9539_PCA9539R v.5
PCA9539_PCA9539R v.5	20080728	Product data sheet	-	PCA9539_PCA9539R v.4
PCA9539_PCA9539R v.4	20080519	Product data sheet	-	PCA9539 v.3
PCA9539 v.3	20060921	Product data sheet	-	PCA9539 v.2
PCA9539 v.2 (9397 750 14048)	20040930	Product data sheet	-	PCA9539 v.1

Table 21. Revision history ...continued

Document ID	Release date	Data sheet status	Change notice	Supersedes
PCA9539 v.1 (9397 750 12898)	20040827	Product data sheet	-	-

19. Legal information

19.1 Data sheet status

Document status ^{[1][2]}	Product status ^[3]	Definition
Objective [short] data sheet	Development	This document contains data from the objective specification for product development.
Preliminary [short] data sheet	Qualification	This document contains data from the preliminary specification.
Product [short] data sheet	Production	This document contains the product specification.

[1] Please consult the most recently issued document before initiating or completing a design.

[2] The term 'short data sheet' is explained in section "Definitions".

[3] The product status of device(s) described in this document may have changed since this document was published and may differ in case of multiple devices. The latest product status information is available on the Internet at URL <http://www.nxp.com>.

19.2 Definitions

Draft — The document is a draft version only. The content is still under internal review and subject to formal approval, which may result in modifications or additions. NXP Semiconductors does not give any representations or warranties as to the accuracy or completeness of information included herein and shall have no liability for the consequences of use of such information.

Short data sheet — A short data sheet is an extract from a full data sheet with the same product type number(s) and title. A short data sheet is intended for quick reference only and should not be relied upon to contain detailed and full information. For detailed and full information see the relevant full data sheet, which is available on request via the local NXP Semiconductors sales office. In case of any inconsistency or conflict with the short data sheet, the full data sheet shall prevail.

Product specification — The information and data provided in a Product data sheet shall define the specification of the product as agreed between NXP Semiconductors and its customer, unless NXP Semiconductors and customer have explicitly agreed otherwise in writing. In no event however, shall an agreement be valid in which the NXP Semiconductors product is deemed to offer functions and qualities beyond those described in the Product data sheet.

19.3 Disclaimers

Limited warranty and liability — Information in this document is believed to be accurate and reliable. However, NXP Semiconductors does not give any representations or warranties, expressed or implied, as to the accuracy or completeness of such information and shall have no liability for the consequences of use of such information. NXP Semiconductors takes no responsibility for the content in this document if provided by an information source outside of NXP Semiconductors.

In no event shall NXP Semiconductors be liable for any indirect, incidental, punitive, special or consequential damages (including - without limitation - lost profits, lost savings, business interruption, costs related to the removal or replacement of any products or rework charges) whether or not such damages are based on tort (including negligence), warranty, breach of contract or any other legal theory.

Notwithstanding any damages that customer might incur for any reason whatsoever, NXP Semiconductors' aggregate and cumulative liability towards customer for the products described herein shall be limited in accordance with the *Terms and conditions of commercial sale* of NXP Semiconductors.

Right to make changes — NXP Semiconductors reserves the right to make changes to information published in this document, including without limitation specifications and product descriptions, at any time and without notice. This document supersedes and replaces all information supplied prior to the publication hereof.

Suitability for use — NXP Semiconductors products are not designed, authorized or warranted to be suitable for use in life support, life-critical or safety-critical systems or equipment, nor in applications where failure or malfunction of an NXP Semiconductors product can reasonably be expected to result in personal injury, death or severe property or environmental damage. NXP Semiconductors and its suppliers accept no liability for inclusion and/or use of NXP Semiconductors products in such equipment or applications and therefore such inclusion and/or use is at the customer's own risk.

Applications — Applications that are described herein for any of these products are for illustrative purposes only. NXP Semiconductors makes no representation or warranty that such applications will be suitable for the specified use without further testing or modification.

Customers are responsible for the design and operation of their applications and products using NXP Semiconductors products, and NXP Semiconductors accepts no liability for any assistance with applications or customer product design. It is customer's sole responsibility to determine whether the NXP Semiconductors product is suitable and fit for the customer's applications and products planned, as well as for the planned application and use of customer's third party customer(s). Customers should provide appropriate design and operating safeguards to minimize the risks associated with their applications and products.

NXP Semiconductors does not accept any liability related to any default, damage, costs or problem which is based on any weakness or default in the customer's applications or products, or the application or use by customer's third party customer(s). Customer is responsible for doing all necessary testing for the customer's applications and products using NXP Semiconductors products in order to avoid a default of the applications and the products or of the application or use by customer's third party customer(s). NXP does not accept any liability in this respect.

Limiting values — Stress above one or more limiting values (as defined in the Absolute Maximum Ratings System of IEC 60134) will cause permanent damage to the device. Limiting values are stress ratings only and (proper) operation of the device at these or any other conditions above those given in the Recommended operating conditions section (if present) or the Characteristics sections of this document is not warranted. Constant or repeated exposure to limiting values will permanently and irreversibly affect the quality and reliability of the device.

Terms and conditions of commercial sale — NXP Semiconductors products are sold subject to the general terms and conditions of commercial sale, as published at <http://www.nxp.com/profile/terms>, unless otherwise agreed in a valid written individual agreement. In case an individual agreement is concluded only the terms and conditions of the respective agreement shall apply. NXP Semiconductors hereby expressly objects to applying the customer's general terms and conditions with regard to the purchase of NXP Semiconductors products by customer.

No offer to sell or license — Nothing in this document may be interpreted or construed as an offer to sell products that is open for acceptance or the grant, conveyance or implication of any license under any copyrights, patents or other industrial or intellectual property rights.

Export control — This document as well as the item(s) described herein may be subject to export control regulations. Export might require a prior authorization from competent authorities.

Non-automotive qualified products — Unless this data sheet expressly states that this specific NXP Semiconductors product is automotive qualified, the product is not suitable for automotive use. It is neither qualified nor tested in accordance with automotive testing or application requirements. NXP Semiconductors accepts no liability for inclusion and/or use of non-automotive qualified products in automotive equipment or applications.

In the event that customer uses the product for design-in and use in automotive applications to automotive specifications and standards, customer (a) shall use the product without NXP Semiconductors' warranty of the product for such automotive applications, use and specifications, and (b) whenever customer uses the product for automotive applications beyond NXP Semiconductors' specifications such use shall be solely at customer's

own risk, and (c) customer fully indemnifies NXP Semiconductors for any liability, damages or failed product claims resulting from customer design and use of the product for automotive applications beyond NXP Semiconductors' standard warranty and NXP Semiconductors' product specifications.

Translations — A non-English (translated) version of a document is for reference only. The English version shall prevail in case of any discrepancy between the translated and English versions.

19.4 Trademarks

Notice: All referenced brands, product names, service names and trademarks are the property of their respective owners.

I²C-bus — logo is a trademark of NXP Semiconductors N.V.

20. Contact information

For more information, please visit: <http://www.nxp.com>

For sales office addresses, please send an email to: salesaddresses@nxp.com

21. Contents

1	General description	1	18	Revision history	35
2	Features and benefits	1	19	Legal information	37
3	Ordering information	2	19.1	Data sheet status	37
3.1	Ordering options	2	19.2	Definitions	37
3.1.1	Pin 1 quadrant indication	3	19.3	Disclaimers	37
4	Block diagram	4	19.4	Trademarks	38
5	Pinning information	5	20	Contact information	38
5.1	Pinning	5	21	Contents	39
5.2	Pin description	6			
6	Functional description	7			
6.1	Device address	7			
6.2	Registers	7			
6.2.1	Command byte	7			
6.2.2	Registers 0 and 1: Input port registers	8			
6.2.3	Registers 2 and 3: Output port registers	8			
6.2.4	Registers 4 and 5: Polarity inversion registers	8			
6.2.5	Registers 6 and 7: Configuration registers	9			
6.3	Power-on reset	9			
6.4	RESET input	9			
6.5	I/O port	9			
6.6	Bus transactions	10			
6.6.1	Writing to the port registers	10			
6.6.2	Reading the port registers	12			
6.6.3	Interrupt output	15			
7	Characteristics of the I²C-bus	15			
7.1	Bit transfer	15			
7.1.1	START and STOP conditions	15			
7.2	System configuration	16			
7.3	Acknowledge	16			
8	Application design-in information	17			
8.1	Minimizing I _{DD} when the I/Os are used to control LEDs	18			
9	Limiting values	18			
10	Static characteristics	19			
11	Dynamic characteristics	21			
12	Test information	25			
13	Package outline	26			
14	Handling information	29			
15	Soldering of SMD packages	29			
15.1	Introduction to soldering	29			
15.2	Wave and reflow soldering	29			
15.3	Wave soldering	29			
15.4	Reflow soldering	30			
16	Soldering: PCB footprints	32			
17	Abbreviations	35			

Please be aware that important notices concerning this document and the product(s) described herein, have been included in section 'Legal information'.

© NXP Semiconductors N.V. 2017.

All rights reserved.

For more information, please visit: <http://www.nxp.com>

For sales office addresses, please send an email to: salesaddresses@nxp.com

Date of release: 8 November 2017

Document identifier: PCA9539_PCA9539R