

REV	DESCRIPTION	ECN	DATE	OWN	APVD
D6	OBSOLETE -3	ECR-07-009593	09MAY07	TS	KB
E	REVISED	ECR-07-014805	09JUL07	KF	HY
E1	REVISED	ECR-12-000967	18JAN2012	TS	KB
E2	REVISED	ECR-16-003439	16MAR2017	KF	TK

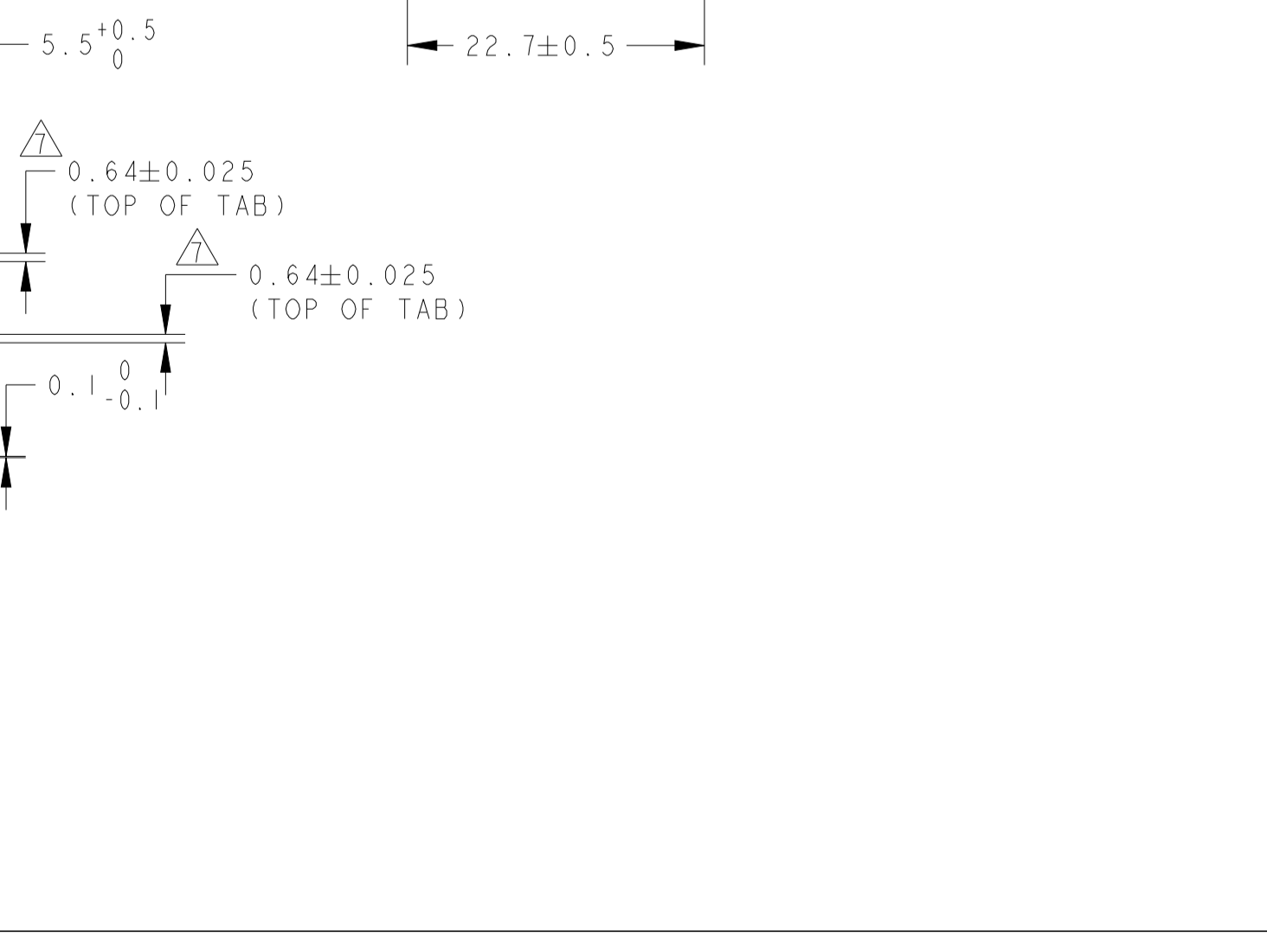
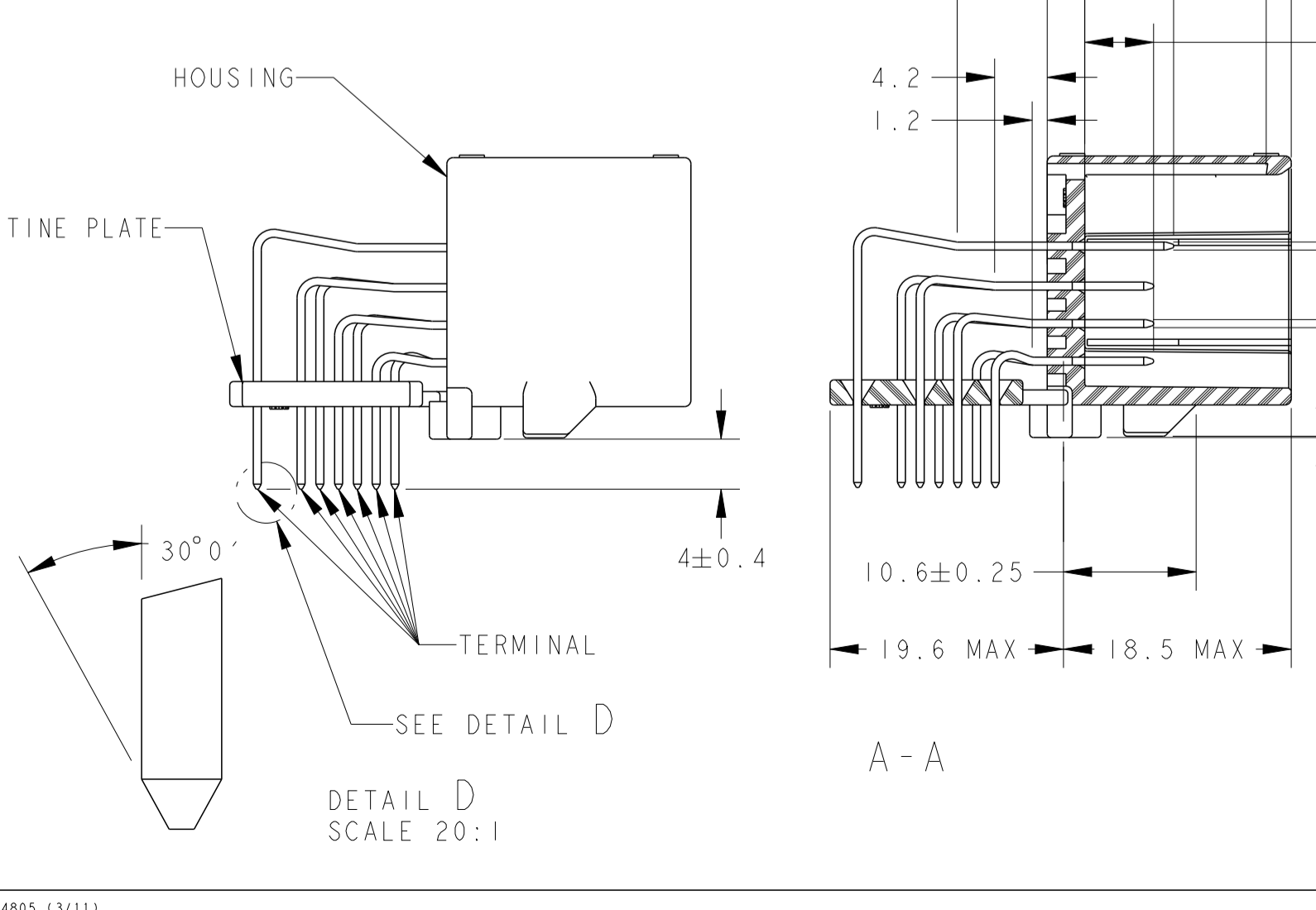
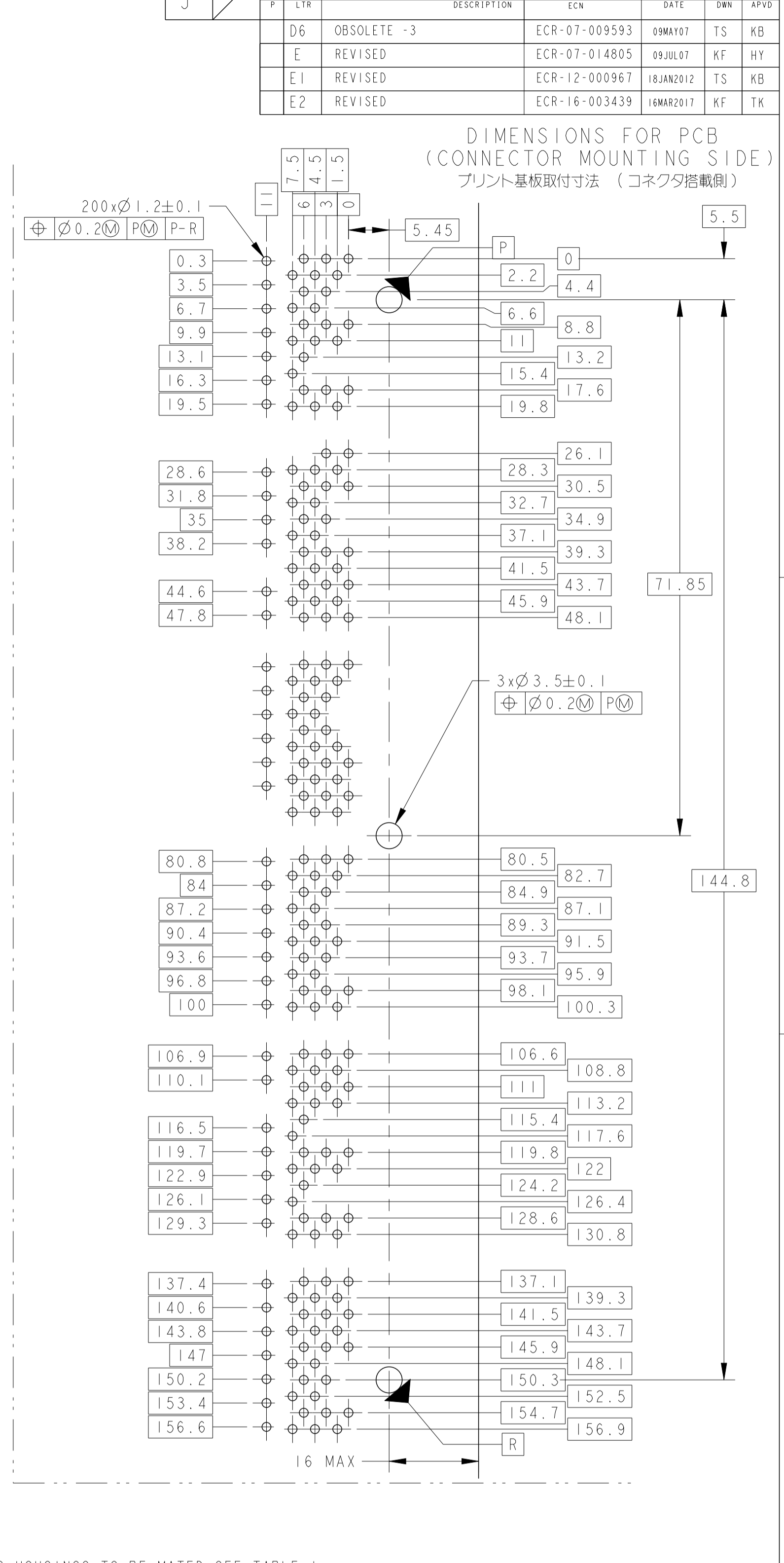
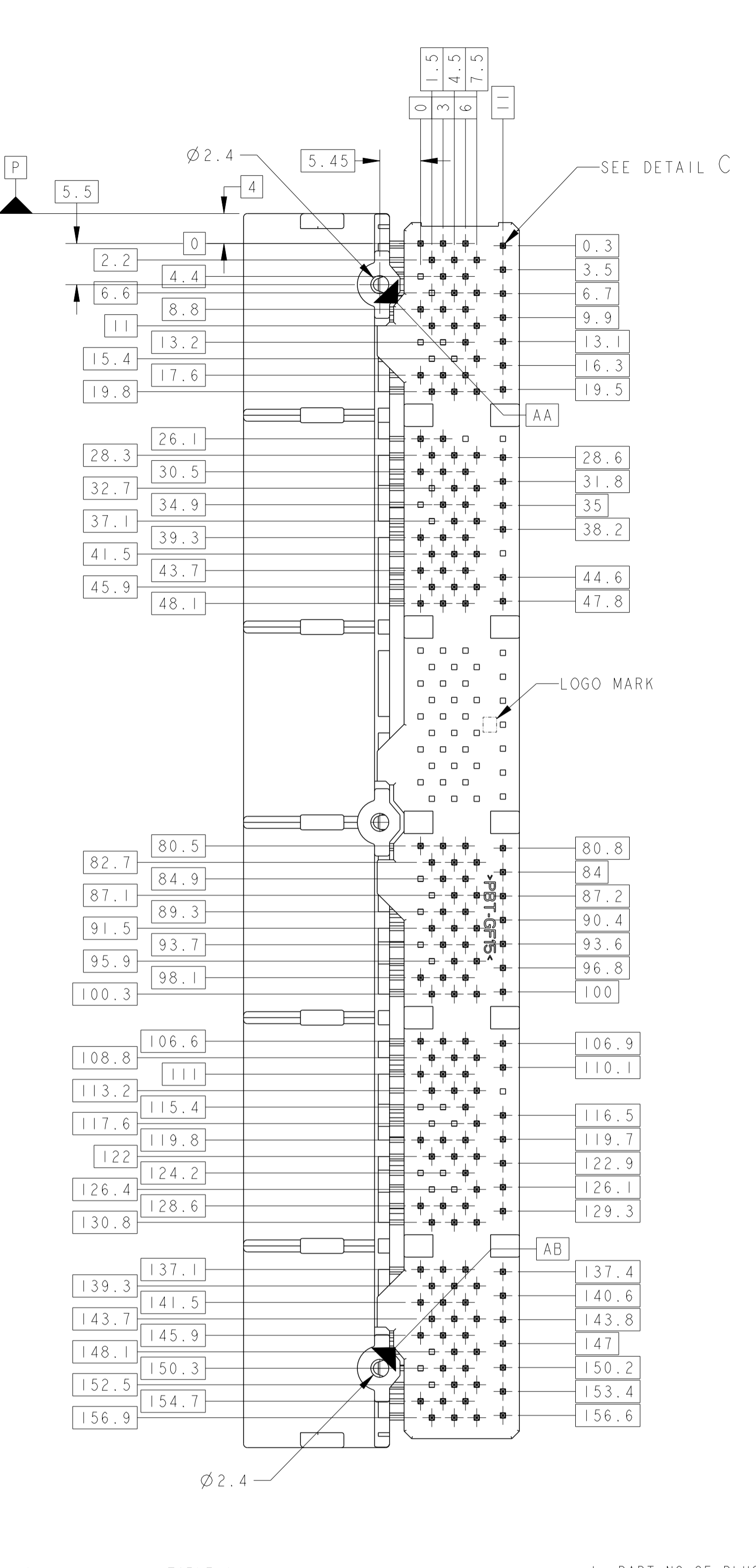
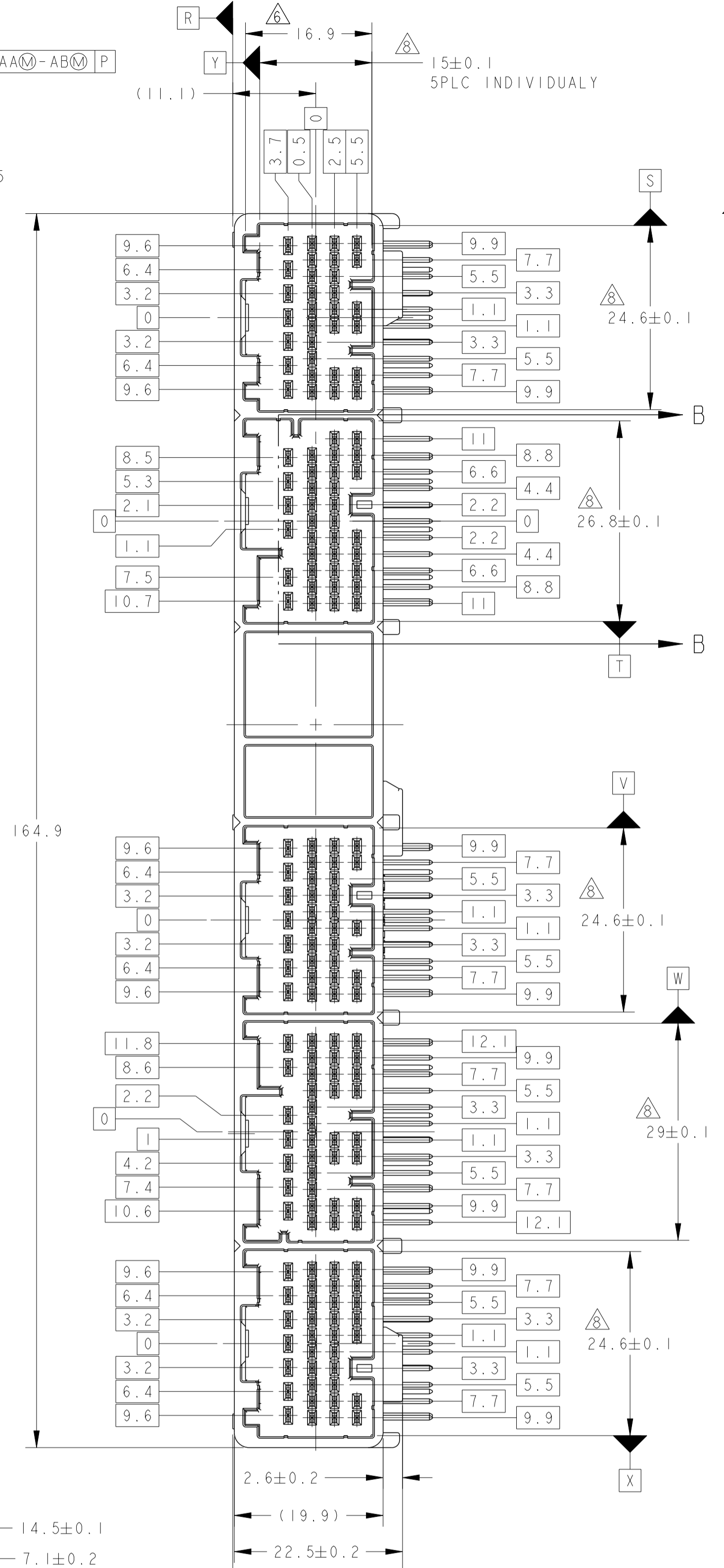
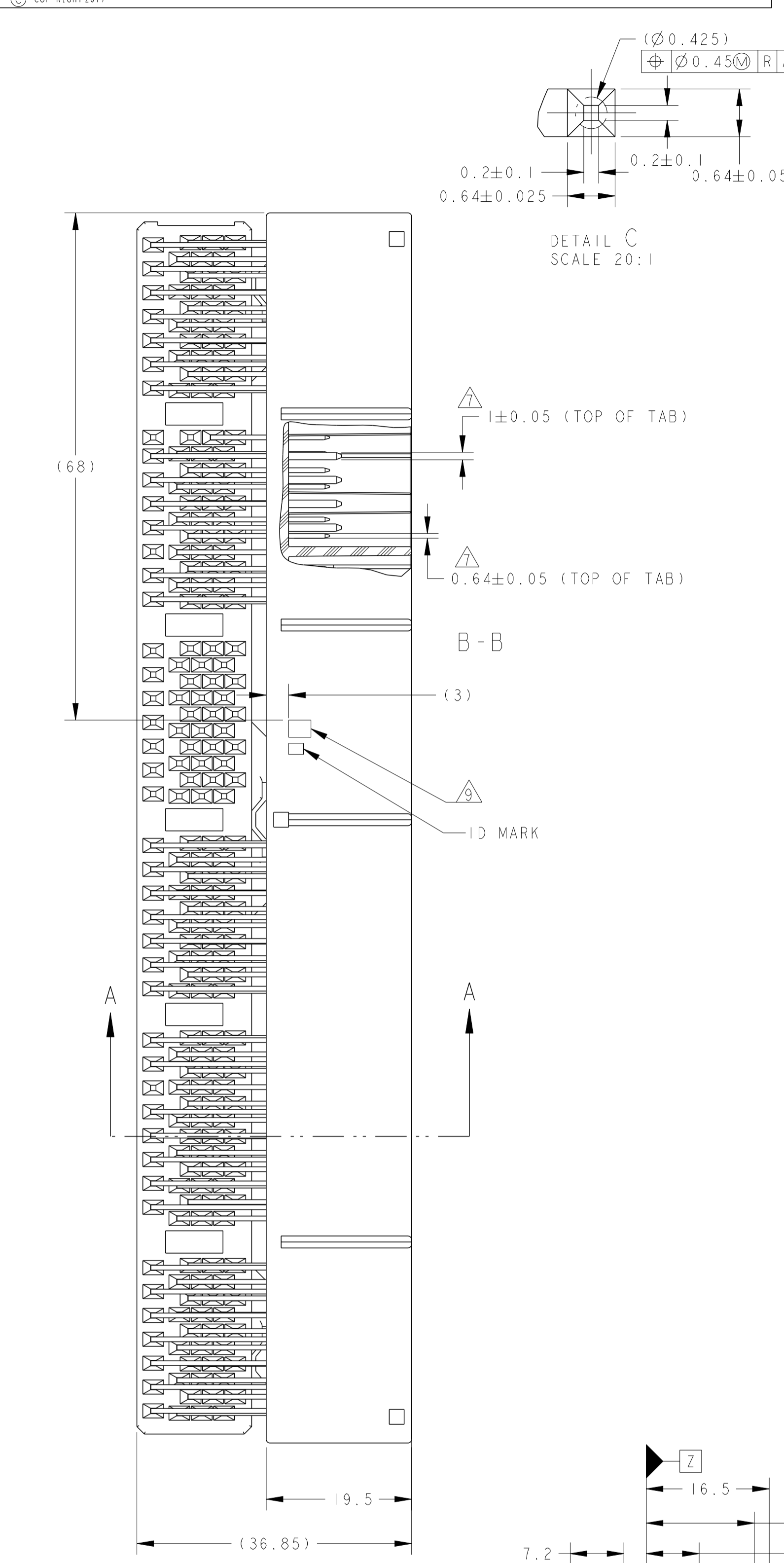

1. 嵌合相手ハウジング型番: TABLE-1 参照
2. パワ回路(32極): FIG-1 参照
3. 回路番号: FIG-1 参照
4. 推奨取り付け: JIS B1115, B1122 タッピングなし、ねじ2種、呼び径3、長さ: TABLE-1 参照
5. ねじ締めトルク: 0.392N·m MAX
6. Z からの 2mm の位置で測定
7. $\phi 0.3$ Z Y M DTM 組し、3次DTMについては、S, T, V, W, X を各々のブロック毎に適用すること
8. Z からの 7.5mm の位置で測定
9. コンタクト仕上識別用マーク: 表参照
10. 取扱説明書 NO.: 411-5932

1. PART NO OF PLUG HOUSINGS TO BE MATED: SEE TABLE 1
2. POWER CIRCUITS (32); SEE FIG-1
3. CIRCUIT NUMBERS; SEE FIG-1
4. RECOMMENDED SCREW: PAN-HEADED, TYPE 2 TAPPING SCREW, NOMINAL DIAMETER 3mm LENGTH; SEE TABLE-1 (JIS B1115, B1122).
5. FASTENING TORQUE FOR SCREW: 0.392N·m MAX.
6. MEASURED AT 2mm FROM Z
7. $\phi 0.3$ Z Y M DTM 組し、3次DTMについては、S, T, V, W, X OF EACH BLOCK.
8. MEASURED AT 7.5mm FROM Z
9. MARKING FOR DESCERNMENT OF THE CONTACT FINISH; SEE TABLE 10.
10. INSTRUCTION SHEET NO.: 411-5932

プリント基板厚 (mm) THICKNESS OF PCB (mm)	1.2	1.6
固定用ねじ着下長さ (mm) NOMINAL LENGTH OF SCREW (mm)	5	6

THIS DRAWING IS A CONTROLLED DOCUMENT.

OWN: H. FURUYAMA	10FEB2000	TE Connectivity
CHK: N. SAI	10FEB2000	
APVD: N. SAI	10FEB2000	SIZE: 025/040 EFL ECU CONNECTOR
PRODUCT SPEC	08-5674	167 POSITION CAP HOUSING ASSEMBLY
APPLICATION SPEC	114-5217, 5250	SIZE: A1
MATERIAL: PBT GF15 BRASS	FINISH: SEE TABLE	WEIGHT: 53.1 g
CUSTOMER DRAWING	SCALE: 2:1	SHEET: 1 OF 3

REVISIONS

REV	DESCRIPTION	ECN	DATE	OWN	APVD
D6	OBSOLETE -3	ECR-07-009593	09MAY07	TS	KB
E	REVISED	ECR-07-014805	09JUL07	KF	HY
E1	REVISED	ECR-12-000967	18JAN2012	TS	KB
E2	REVISED	ECR-16-003439	16MAR2017	KF	TK

4805 (3/11)

THIS DRAWING IS UNPUBLISHED. RELEASED FOR PUBLICATION 2017
 © COPYRIGHT 2017 ALL RIGHTS RESERVED.

LOC	DIST	REVISIONS					
J	-	P	LTR	DESCRIPTION	DATE	DWN	APVD
				SEE SHEET 1 OF 3			

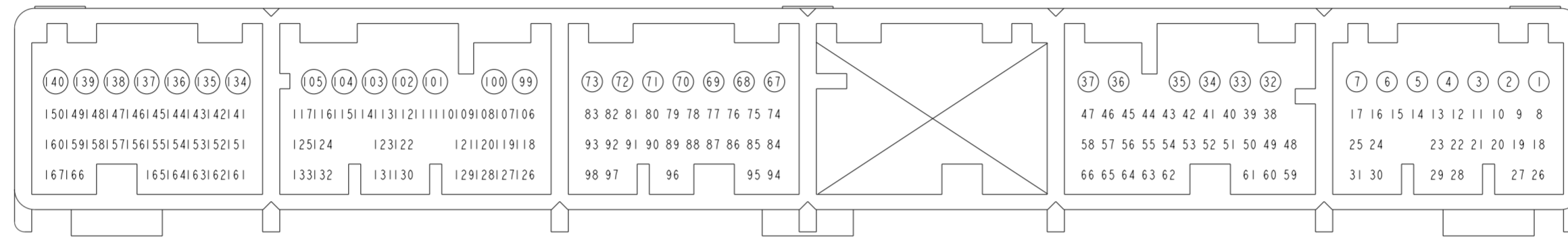

③ FIG 1 CIRCUIT NUMBERS ⑦ ; 040 CONTACT

62	PLASTIC BOX 通い箱	PLASTIC TUBE プラスチックチューブ	SELECTIVE-TIN (MATTE)	SELECTIVE GOLD X 135 SERECTIVE-TIN X 32 (BRIGHT)	99,100	8~31,38~66,74~98, 106~133,141~167	GRAY (灰色)	6318813-6
62	PLASTIC BOX 通い箱	PLASTIC TUBE プラスチックチューブ	SELECTIVE-TIN (MATTE)	SELECTIVE GOLD X 135 SERECTIVE-TIN X 32 (BRIGHT)	99,100	8~31,38~66,74~98, 106~133,141~167	BLACK (黒色)	6318813-2
61	PAPER BOX ダンボール箱	PLASTIC TUBE プラスチックチューブ	SELECTIVE-TIN (MATTE)	SELECTIVE GOLD X 83 SERECTIVE-TIN X 84 (BRIGHT)	99,100	18~31,48~66,84~98, 118~133,151~167	NATURAL (自然色)	6318813-3
61	PLASTIC BOX 通い箱	PLASTIC TUBE プラスチックチューブ	SELECTIVE-TIN (MATTE)	SELECTIVE GOLD X 83 SERECTIVE-TIN X 84 (BRIGHT)	99,100	18~31,48~66,84~98, 118~133,151~167	NATURAL (自然色)	6318813-1
3	PLASTIC BOX 通い箱	PLASTIC TUBE プラスチックチューブ	SELECTIVE-TIN (MATTE)	SELECTIVE-TIN X 167 (BRIGHT)	-	-	NATURAL (自然色)	1318813-7
③ MARKING (マーキング)	OUTER 外表	INNER 内装	SOLDERING SIDE 半田付け部	CONTACT SIDE 接触部側	040TAB	025 TAB	COLOR (色)	PART NUMBER (型番)
PACKING STYLE 梱包形態			CONTACT FINISH (仕上げ)		GOLD PLATED CIRCUIT NO (金めっき回路番号)			

THIS DRAWING IS A CONTROLLED DOCUMENT.

DWN K. FURUYAMA	10FEB2000	 TE Connectivity NAME 025/040 EFI ECU CONNECTOR 167 POSITION CAP HOUSING ASSEMBLY
CHK N. SAI	10FEB2000	
APVD N. SAI	10FEB2000	
PRODUCT SPEC 製品規格	SEE 1 OF 3	
APPLIC. SPEC 取付適用規格	SEE 1 OF 3	SIZE A2
MATERIAL 材料	SEE 1 OF 3	CAGE CODE 00779
FINISH 仕上	SEE 1 OF 3	DRAWING NO G-1318813
CUSTOMER DRAWING		RESTRICTED TO -
SCALE 1:1		SHEET 2 OF 3
		REV E2

THIS DRAWING IS UNPUBLISHED. RELEASED FOR PUBLICATION 2017
 © COPYRIGHT 2017 ALL RIGHTS RESERVED.

LOC	DIST	REVISIONS					
J	-	P	LTR	DESCRIPTION	DATE	DWN	APVD
				SEE SHEET 1 OF 3			

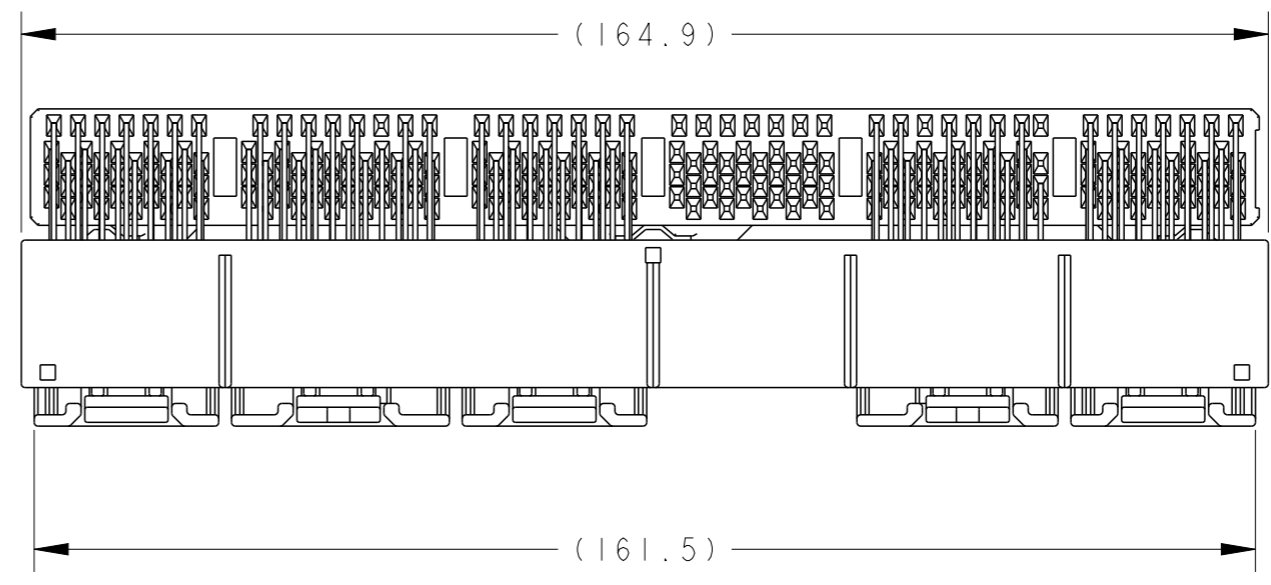
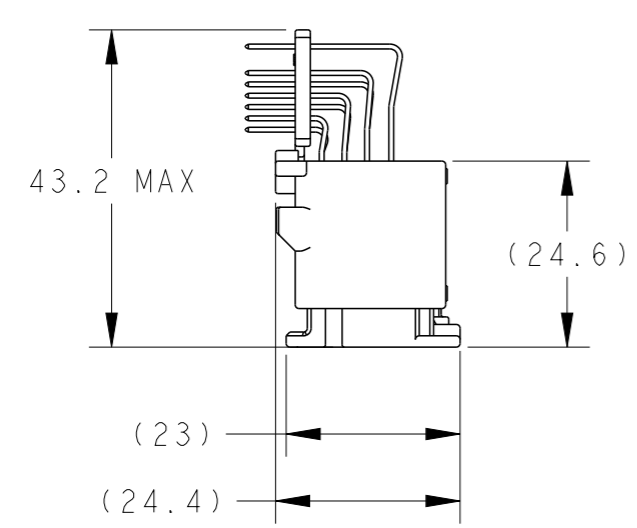

CAP ASSEMBLY & PLUG ASSEMBLY ENGAGEMENT DRAWING
 キャップアッセンブリ & プラグアッセンブリ 嵌合図

TABLE - 1

POSITION 極数	PART NUMBER 型番
34	1123337, 1674925
35	1123338, 1674558
32	1123339, 1674922
35	1123340, 1674928
31	1123341, 1674919

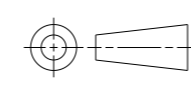
THIS DRAWING IS A CONTROLLED DOCUMENT.		DWN K. FURUYAMA 10FEB2000	 TE Connectivity	
DIMENSIONS: 単位: 耗 mm		CHK N. SAI 10FEB2000		
TOLERANCES UNLESS OTHERWISE SPECIFIED: 一般公差 = ± 0.3		APVD N. SAI 10FEB2000	NAME 名称 025/040 EFI ECU CONNECTOR 167P CAP HOUSING ASSY	
		PRODUCT SPEC 製品規格 SEE 1 OF 3	SIZE A3	
MATERIAL 材料 SEE 1 OF 3		APPLICATION SPEC 取付適用規格 SEE 1 OF 3	CAGE CODE 00779	DRAWING NO 番号 C-1318813
FINISH 仕上 SEE 1 OF 3		WEIGHT SEE 1 OF 3	RESTRICTED TO	
CUSTOMER DRAWING		SCALE 尺度 1:1		SHEET 3 OF 3
				REV E2