

AC/DC Drivers

# PWM Control IC

## BM1P105FJ

• **General**

The PWM control IC for AC/DC “BM1P105FJ” provides an optimum system for all products that include an electrical outlet.

A built-in start circuit that withstands 650 V helps to keep power consumption low. Both isolated and non-isolated versions are supported, making for simpler design of various types of low-power converters. Switching MOSFET and current detection resistors are external devices, thus achieving a higher degree of freedom in power supply design. The switching frequency is set as fixed. Since current mode control is used, a current limit is imposed in each cycle, and excellent performance is demonstrated in bandwidth and transient response. With a light load, frequency is reduced and higher efficiency is realized. A frequency hopping function is also built in, contributing to low EMI.

Also on chip are soft start and burst functions, a per-cycle overcurrent limiter, VCC overvoltage protection, overload protection, and other protection functions.

• **Basic Specifications**

- Operating power supply voltage range: VCC 8.9 V to 26.0 V  
VH: to 600 V
- Operating current: Normal: 0.60 mA (Typ.)  
Burst mode: 0.35 mA (Typ.)
- Oscillation frequency: BM1P105FJ: 100 kHz (Typ.)
- Operating temperature range: -40°C to +85°C

• **Application circuit**

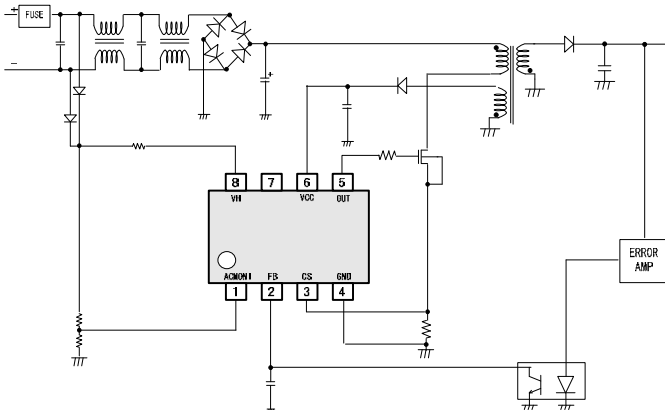

Figure 1. Application Circuit

• **Features**

- PWM frequency: 100 kHz
- PWM current mode method
- Frequency hopping function
- Burst operation during light load / Frequency reduction function
- 650 V start circuit
- VCC pin undervoltage protection
- VCC pin overvoltage protection
- CS pin open protection
- CS pin Leading-Edge-Blanking function
- Per-cycle overcurrent limiter function
- Overcurrent limiter with AC voltage compensation function
- Soft start function
- Secondary overcurrent protection circuit

• **Package**

SOP-J8 4.90 mm × 6.00 mm × 1.65 mm pitch 1.27 mm  
(Typ.) (Typ.) (Typ.) (Typ.)



• **Applications**

AC adapters, TVs, and household appliances (vacuum cleaners, humidifiers, air cleaners, air conditioners, IH cooking heaters, rice cookers, etc.)

• **Line-up**

	Frequency	VCCOVP	VCC recharge	X-cap discharge	Brown-out
BM1P061FJ	65kHz	Auto-restart	○	○	○
BM1P062FJ	65kHz	Latch	○	○	○
BM1P063FJ	65kHz	Auto-restart	○	×	×
BM1P064FJ	65kHz	Latch	○	×	×
BM1P065FJ	65kHz	Auto-restart	×	×	○
BM1P066FJ	65kHz	Latch	×	×	○
BM1P067FJ	65kHz	Auto-restart	×	×	×
BM1P068FJ	65kHz	Latch	×	×	×
BM1P101FJ	100kHz	Auto-restart	○	○	○
BM1P102FJ	100kHz	Latch	○	○	○
BM1P103FJ	100kHz	Auto-restart	○	×	×
BM1P104FJ	100kHz	Latch	○	×	×
BM1P105FJ	100kHz	Auto-restart	×	×	○
BM1P106FJ	100kHz	Latch	×	×	○
BM1P107FJ	100kHz	Auto-restart	×	×	×
BM1P108FJ	100kHz	Latch	×	×	×

• Absolute Maximum Ratings (Ta = 25°C)

Parameter	Symbol	Rating	Unit	Conditions
Maximum voltage 1	Vmax1	-0.3 ~ 30.0	V	VCC
Maximum voltage 2	Vmax2	-0.3 ~ 6.5	V	CS, FB, ACMONI
Maximum voltage 3	Vmax3	-0.3 ~ 15.0	V	OUT
Maximum voltage 4	Vmax4	-0.3 ~ 650	V	VH
OUT pin peak current	I <sub>OUT</sub>	±1.0	A	
Allowable dissipation	P <sub>d</sub>	674.9 (Note1)	mW	When mounted
Operating temperature range	T <sub>opr</sub>	-40 ~ +85	°C	
Storage temperature range	T <sub>str</sub>	-55 ~ +150	°C	

(Note1) SOP-J8: When mounted, 70 × 70 × 1.6 mm (glass epoxy on single-layer substrate). Reduce to 5.40 mW/°C when used at Ta = 25°C or above.

• Recommended Operating Conditions (Ta = 25°C)

Parameter	Symbol	Rating	Unit	Conditions
Supply voltage range 1	VCC	8.9 ~ 26.0	V	VCC pin voltage
Supply voltage range 2	VH	80 ~ 600	V	VH pin voltage

• Electrical Characteristics (Unless otherwise noted, Ta = 25°C, VCC = 15 V)

Parameter	Symbol	Rating			Unit	Conditions
		Min.	Typ.	Max.		
<b>[Circuit current]</b>						
Circuit current (ON) 1	I <sub>ON1</sub>	-	600	1000	μA	FB = 2.0 V (during pulse operation)
Circuit current (ON) 2	I <sub>ON2</sub>	-	350	450	μA	FB = 0.0 V (during burst operation)
<b>[VCC pin (5 pin) protection function ]</b>						
VCC UVLO voltage 1	V <sub>UVLO1</sub>	12.50	13.50	14.50	V	VCC rise
VCC UVLO voltage 2	V <sub>UVLO2</sub>	7.50	8.20	8.90	V	VCC drop
VCC UVLO hysteresis	V <sub>UVLO3</sub>	-	5.30	-	V	V <sub>UVLO3</sub> = V <sub>UVLO1</sub> - V <sub>UVLO2</sub>
VCC OVP voltage 1	V <sub>OVP1</sub>	26.00	27.50	29.00	V	VCC rise
VCC OVP voltage 2	V <sub>OVP2</sub>	-	23.50	-	V	VCC drop
VCC OVP hysteresis	V <sub>OVP3</sub>	-	4.00	-	V	
<b>[Output driver block]</b>						
OUT pin H voltage	V <sub>OUTH</sub>	10.5	12.5	14.5	V	IO = -20 mA
OUT pin L voltage	V <sub>OUTL</sub>	-	-	1.00	V	IO = +20 mA
OUT pin pull-down resistance	R <sub>PDOUT</sub>	75	100	125	kΩ	
<b>[ACMONI detection circuit]</b>						
ACMONI detection voltage1	V <sub>ACMONI1</sub>	0.92	1.00	1.08	V	ACMONI rises
ACMONI detection voltage2	V <sub>ACMONI2</sub>	0.63	0.70	0.77	V	ACMONI falls
ACMONI Hysteresis	V <sub>ACMONI3</sub>	0.20	0.30	0.40	V	
ACMONI Timer	T <sub>ACMONI1</sub>	180	256	330	ms	
<b>[Start circuit block]</b>						
Start current 1	I <sub>START1</sub>	0.400	0.700	1.000	mA	VCC = 0 V
Start current 2	I <sub>START2</sub>	1.000	3.000	5.000	mA	VCC = 10 V
OFF current	I <sub>START3</sub>	-	10	20	μA	Inflow current from VH pin after release of UVLO
Start current switching voltage	V <sub>SC</sub>	0.400	0.800	1.400	V	

• Electrical characteristics of control IC block (Unless otherwise noted, Ta = 25°C, VCC = 15 V)

Parameter	Symbol	Rating			Unit	Conditions
		Min.	Typ.	Max.		
<b>[PWM type DC/DC driver block]</b>						
Oscillation frequency 1a	$F_{SW1a}$	90	100	110	kHz	FB = 2.00 V average frequency
Oscillation frequency 2	$F_{SW2}$	-	25	-	kHz	FB = 0.40 V average frequency
Frequency hopping range	$F_{DEL1}$	-	6.0	-	kHz	FB = 2.00 V average frequency
Hopping fluctuation frequency	$F_{CH}$	75	125	175	Hz	
Minimum pulse width	$T_{min}$	-	400	-	ns	
Soft start time 1	$T_{SS1}$	0.30	0.50	0.70	ms	
Soft start time 2	$T_{SS2}$	0.60	1.00	1.40	ms	
Soft start time 3	$T_{SS3}$	1.20	2.00	2.80	ms	
Soft start time 4	$T_{SS4}$	2.40	4.00	5.60	ms	
Maximum duty	$D_{max}$	68.0	75.0	82.0	%	
FB pin pull-up resistance	$R_{FB}$	22	30	38	kΩ	
FB / CS gain	Gain	-	4.00	-	V/V	
FB burst voltage 1	$V_{BST1}$	0.300	0.400	0.500	V	FB drop
FB burst voltage 2	$V_{BST2}$	0.350	0.450	0.550	V	FB rise
FBOLP voltage 1a	$V_{FOLP1A}$	2.60	2.80	3.00	V	When overload is detected (FB rise)
FBOLP voltage 1b	$V_{FOLP1B}$	-	$V_{FOLP2A}-0.2$	-	V	When overload is detected (FB drop)
FBOLP detection timer	$T_{FOLP}$	44	64	84	ms	
<b>[Overcurrent detection block]</b>						
Overcurrent detection voltage	$V_{CS}$	0.380	0.400	0.420	V	Ton = 0 us
Overcurrent detection voltage SS1	$V_{CS\_SS1}$	-	0.100	-	V	0 [ms] ~ Tss1 [ms]
Overcurrent detection voltage SS2	$V_{CS\_SS2}$	-	0.150	-	V	TSS1 [ms] ~ TSS2 [ms]
Overcurrent detection voltage SS3	$V_{CS\_SS3}$	-	0.200	-	V	TSS2 [ms] ~ TSS3[ms]
Overcurrent detection voltage SS4	$V_{CS\_SS4}$	-	0.300	-	V	TSS3 [ms] ~ TSS4 [ms]
Leading edge blanking time	$T_{LEB}$	-	250	-	ns	
Overcurrent detection AC compensation factor	$K_{CS}$	12	20	28	mV/us	

• Pin Descriptions

Table1. I/O Pin Functions

No.	Pin Name	I/O	Function	ESD Diode	
				VCC	GND
1	ACMONI	I	Comparator input pin	-	○
2	FB	I	Feedback signal input pin	○	○
3	CS	I	Primary current sense pin	○	○
4	GND	I/O	GND pin	○	-
5	OUT	O	External MOS drive pin	○	○
6	VCC	I/O	Power supply input pin	-	○
7	N.C.	-	Non Connection	-	-
8	VH	I	Start circuit pin	-	○

• I/O Equivalent Circuit Diagram

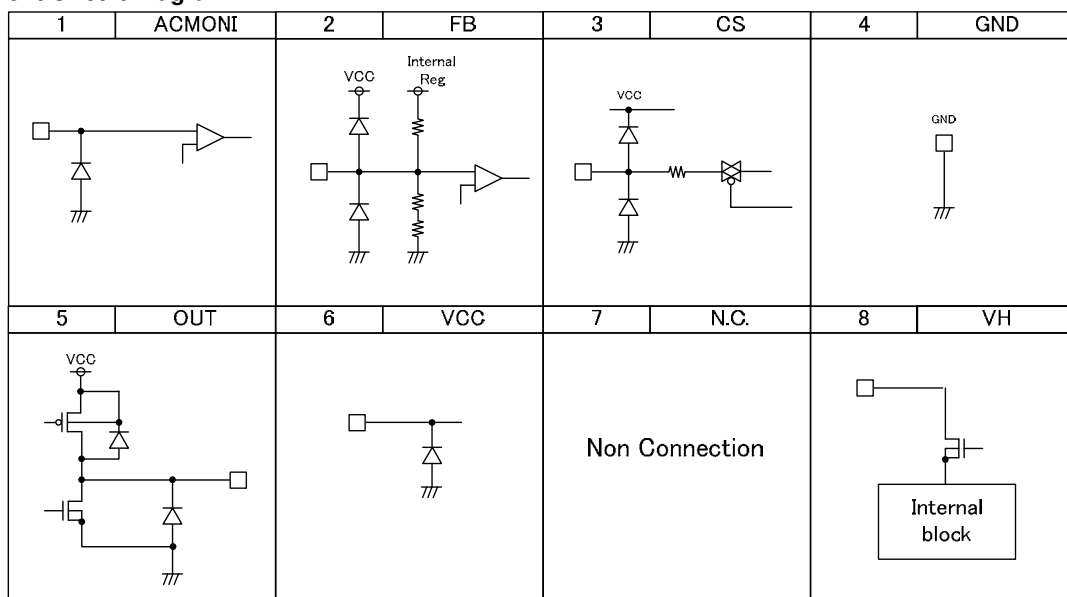

Figure 2. I/O Equivalent Circuit Diagram

• Block Diagram

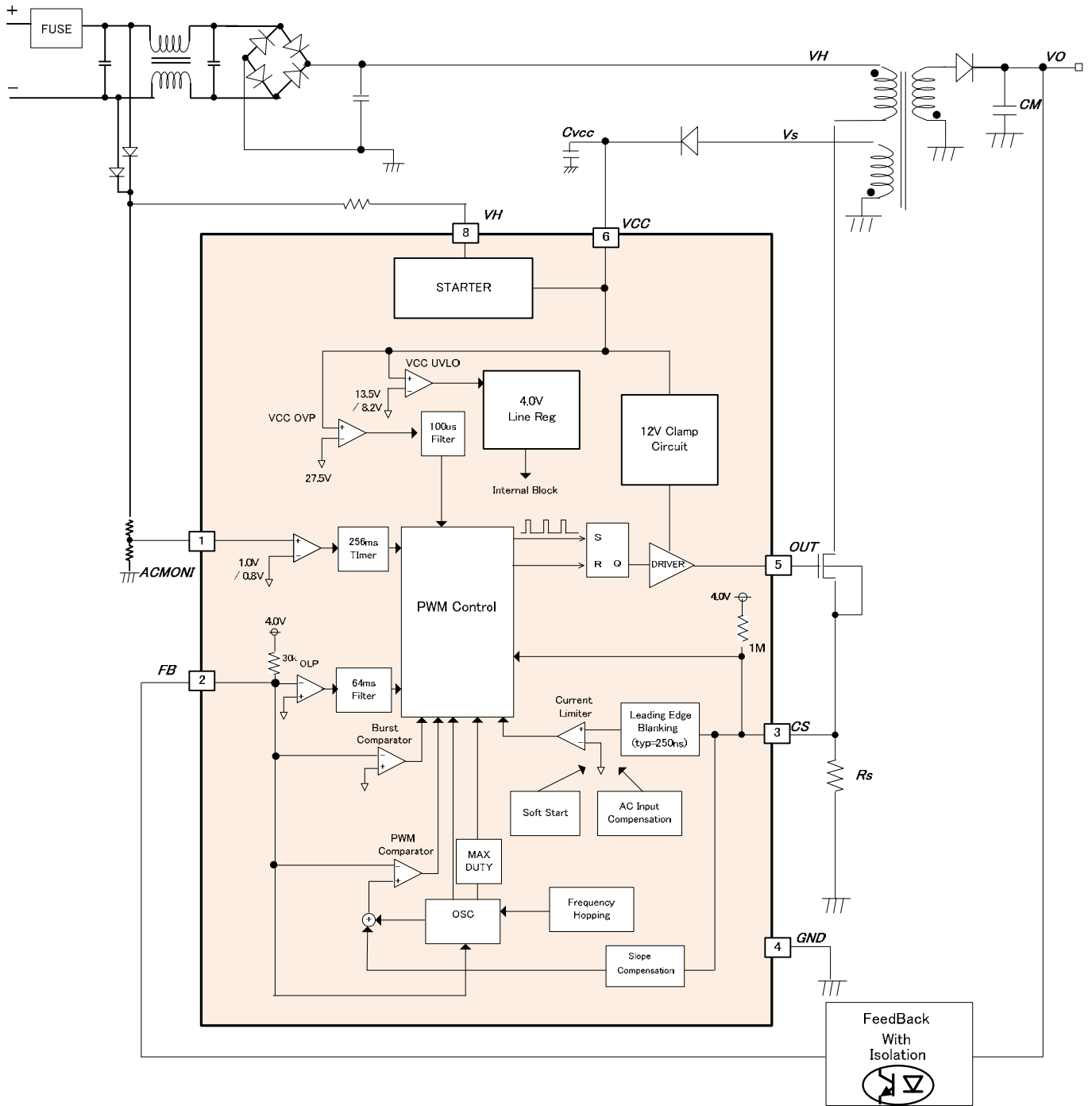

Figure 3. Block Diagram

• Description of application operations in blocks

(1) Start circuit (VH pin: 8 pin)

This IC has a built-in start circuit (withstands 650 V). This enables both low standby mode power and high-speed startup.

This start circuit operates only at startup. The current flow when operating is shown in Figure 5.

After startup, the power consumed is only for the idling current  $I_{START3}$  (typ = 10  $\mu$ A).

ex) When  $V_{ac} = 100$  V, power consumption is from start circuit only  
 $P_{VH} = 100$  V $\cdot\sqrt{2}$  $\cdot 10$   $\mu$ A = 1.41 mW

ex) When  $V_{ac} = 240$  V, power consumption is from start circuit only  
 $P_{VH} = 240$  V $\cdot\sqrt{2}$  $\cdot 10$   $\mu$ A = 3.38 mW

Startup time is determined based on the inflow current for the VH pin and the capacitance for the VCC pin.

Startup time reference values are shown in Figure 6. For example, when  $C_{VCC} = 10$   $\mu$ F, startup takes about 0.07 seconds.

When the VCC pin has been shorted to GND, the ISTART1 current in Figure 5 flows.

When the VH pin has been shorted to GND, a large current flows to GND from the VH line. To prevent this, insert resistor  $R_{VH}$  (5 k $\Omega$  ~ 60 k $\Omega$ ) to limit the current between the VH line and the VH pin of the IC.

When the VH pin is shorted, the power of  $VH^2/R_{VH}$  is applied to the resistor. Therefore, select a resistor size that is able to tolerate this amount of power.

If one resistor is not enough for the allowable power, connect two or more resistors in series.

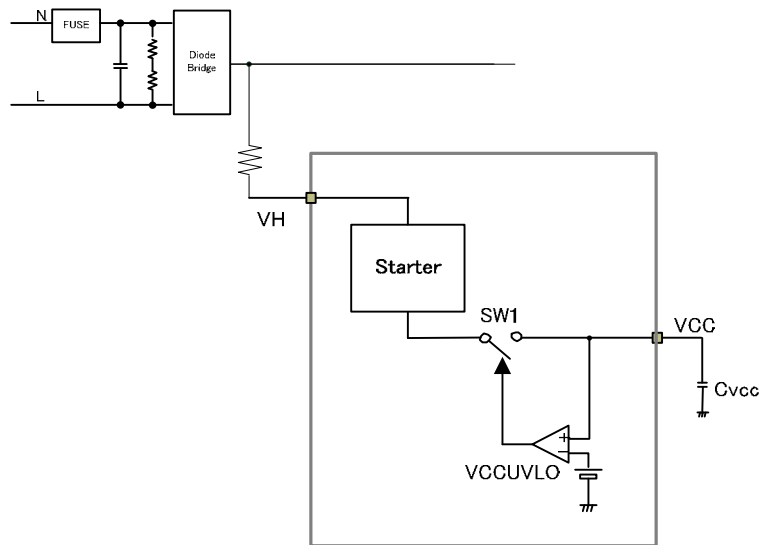

Figure 4. Block Diagram of Start Circuit

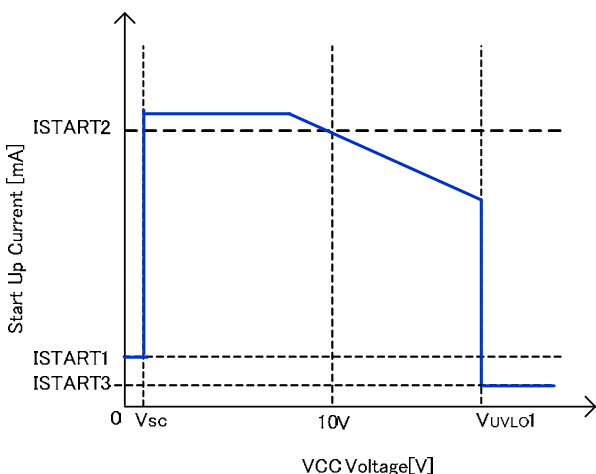

Figure 5. Start Current vs VCC Voltage

(\* Start current flows from the VH pin.)

The operating waveform at startup is as follows.

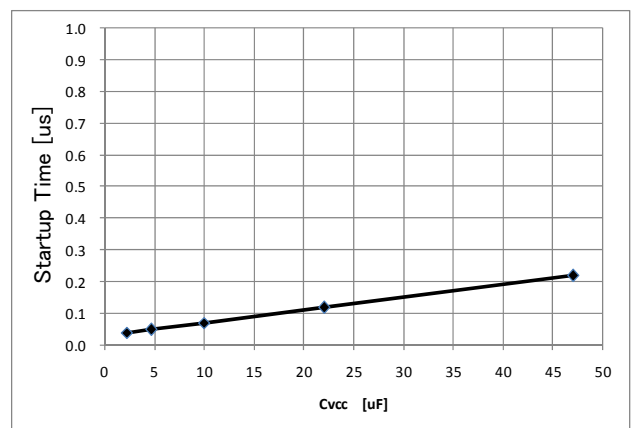

Figure 6. Startup Time (Reference Value)

( $C_{VCC}$  is capacitance for the VCC pin.)

The operating waveform at startup is shown in Figure 7.

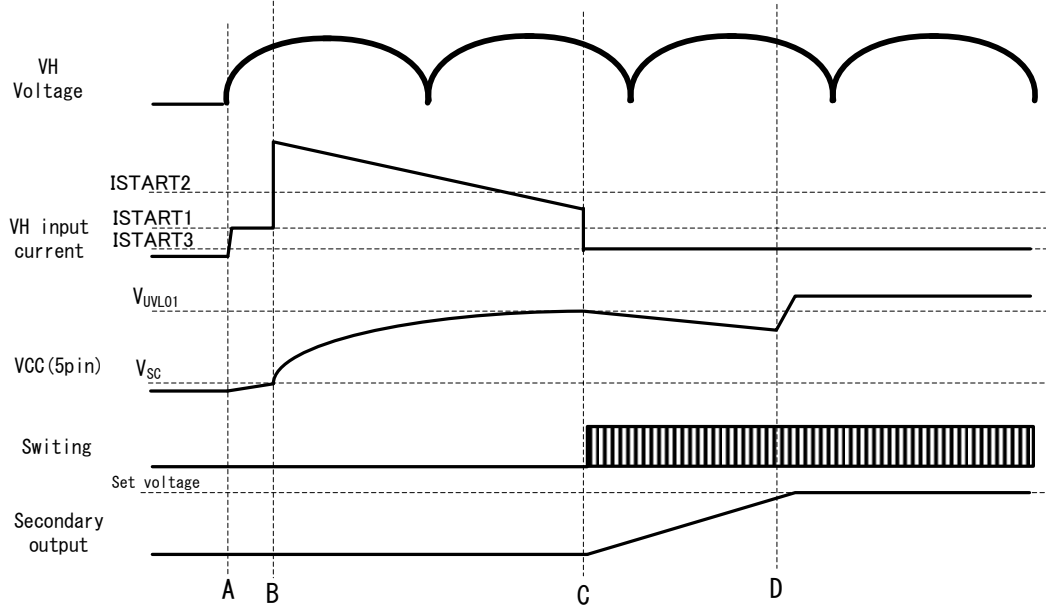

Figure 7. Operating Waveform at Startup

- A: VH voltage is applied when plugged into the outlet. At that time, charging starts from the VH pin via the start circuit to the VCC pin.  
At that time,  $V_{CC} < V_{SC}$  (typ = 0.8 V), so the VH input current is limited to ISTART1 by the VCC pin short protection function.
- B: Since  $V_{CC} > V_{SC}$  (typ = 0.8 V), VCC short protection is cancelled and current flow is from the VH input current.
- C: Since  $V_{CC} > V_{UVLO1}$  (typ = 13.5 V), the start circuit is stopped and the VH input current flow is only ISTART3 (typ = 10  $\mu$ A).  
When switching starts, secondary output begins to increase, but since secondary output is low, the VCC pin voltage is reduced. The drop rate of VCC is determined by the consumption current between the VCC pin capacitor and the IC and by the load current connected to the VCC pin. ( $V/t = C_{VCC}/I_{CC}$ )
- D: Since secondary output has risen to a constant voltage, voltage is applied from the auxiliary winding to the VCC pin, and VCC voltage is stabilized.

**(2) Startup sequences (soft start operation, light load operation, auto recovery operation during overload protection)**

Startup sequences are shown in Figure 8.  
See the sections below for detailed descriptions.

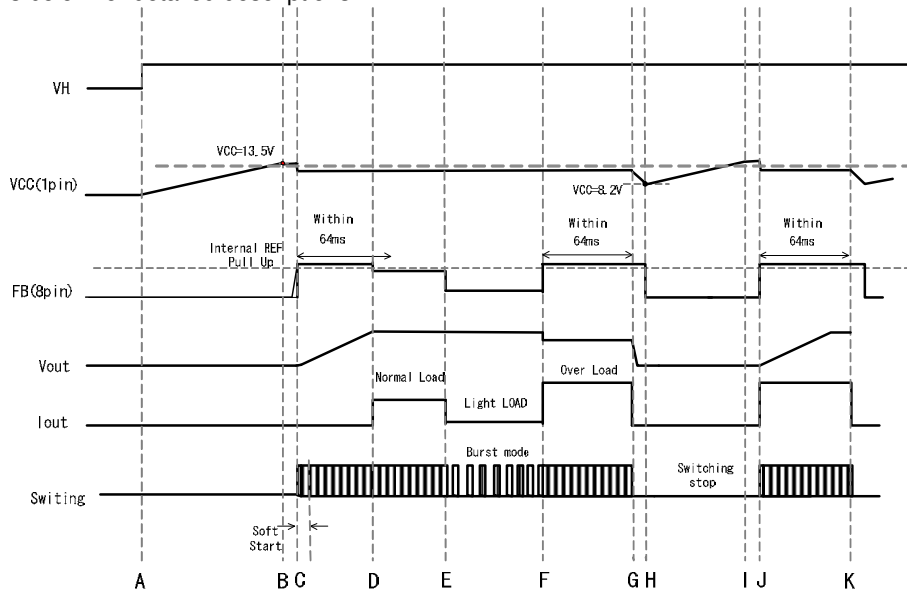

Figure 8. Startup Sequence Time Chart

- A: Voltage is applied to the input voltage (VH) pin (pin 8).
- B: The VCC pin (pin 6) voltage rises, and when  $VCC > V_{UVLO1}$  (13.5 V typ) this IC starts to operate.  
When protection functions (ACMONI, VCC, CS, FB pin, temperature) are judged as normal, switching operation begins. At this time, the VCC pin (pin 6) consumption current necessarily causes the VCC pin voltage to drop. When  $VCC < V_{UVLO2}$  (8.2 V typ), switching operation stops by VCC UVLO function. For that, set VCC capacitor to finish start-up before  $VCC < V_{UVLO2}$  (8.2V.typ)
- C: With the soft start function, excessive rises in voltage and current are prevented by adjusting the voltage level of the CS pin (pin 3). During a soft start, the IC changes the overcurrent detection voltage from  $V_{CC\_SS1}$  to  $V_{CC\_SS4}$  to prevent overshoot of the output voltage.  $V_{CC\_SS1}$  is described in Table 2 below.

Table 2 Overcurrent Detection Voltage at Startup

Soft start	Vlim1
Start ~ 0.5 ms	0.10 V (12%)
0.5 ms ~1 ms	0.15 V (25%)
1 ms ~2 ms	0.20 V (50%)
2 ms ~4 ms	0.30 V (75%)
4 ms ~	0.500 V (100%)

- D: When the switching operation starts, the secondary output voltage VOUT rises.  
After switching has started, set the output voltage to within  $T_{FOLP}$  (64 ms typ) to become the rated voltage.
- E: When there is a light load, burst operation suppresses power consumption.
- F: When there is an overload, the FB pin (pin 2) voltage becomes greater than  $V_{FOLP1A}$  to reduce the output voltage.
- G: If the FB pin (pin 2) voltage exceeds  $V_{FOLP1A}$  for  $T_{FOLP}$  (64 ms typ) or longer, the overload protection circuit stops the switching operation. For that, set to finish the start-up time within  $T_{FOLP}$  (64 ms typ).  
When the FB pin (pin 2) voltage exceeds  $V_{FOLP1B}$ , the IC's internal timer  $T_{FOLP}$  (64 ms typ) is reset.
- H: When VCC voltage becomes  $VCC < V_{UVLO2}$  (8.2 V typ), the start circuit operates and VCC charging is started.
- I: When VCC voltage becomes  $VCC > V_{UVLO1}$  (13.5 V typ), the start circuit stops charging VCC.
- J: Same as F
- K: Same as G

Startup waveforms are shown as reference examples in Figure 9 and Figure 10.



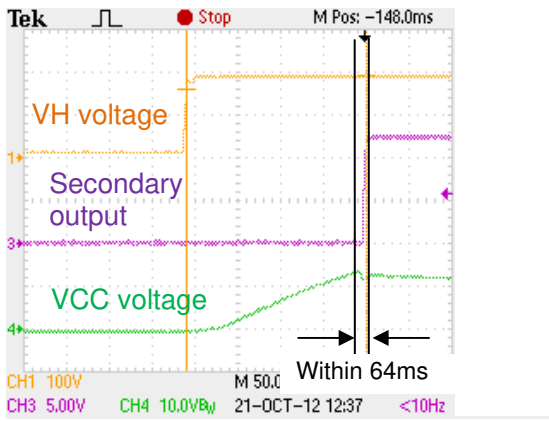

Figure 9. Waveform of No-load Startup

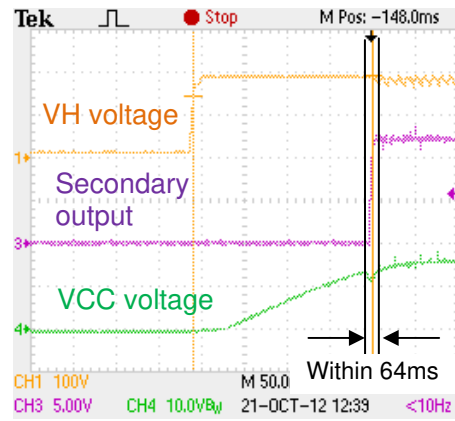

Figure 10. Waveform of High-load Startup

**(3) VCC pin protection function**

This IC includes a VCC pin under voltage protection function VCC UVLO (Under Voltage Protection) and overvoltage protection function VCC OVP (Over Voltage Protection).

The VCC UVLO function and VCC OVP function prevent damage to the switching MOSFET that can occur when the VCC voltage drops or becomes excessive.

**(3-1) VCC UVLO and VCC OVP functions**

VCC UVLO is an auto recovery type comparator with voltage hysteresis. For VCC OVP, the BM1P105FJ has an auto recovery type comparator.

After VCCOVP operation detects, switching operation re-start when  $V_{CC} < V_{OVP2}$  (typ=23.5V).

The operation is shown in Figure 11.

A mask time  $T_{LATCH}$  (typ = 100 us) is built in for VCC OVP to prevent miss-detection. The detection is performed when the VCC pin (pin 6) voltage continues to exceed  $V_{OVP1}$  (typ = 27.5 V) for  $T_{LATCH}$  (typ = 100 us).

This function masks surges or the like that occur at the pin. (See section (7) below.)

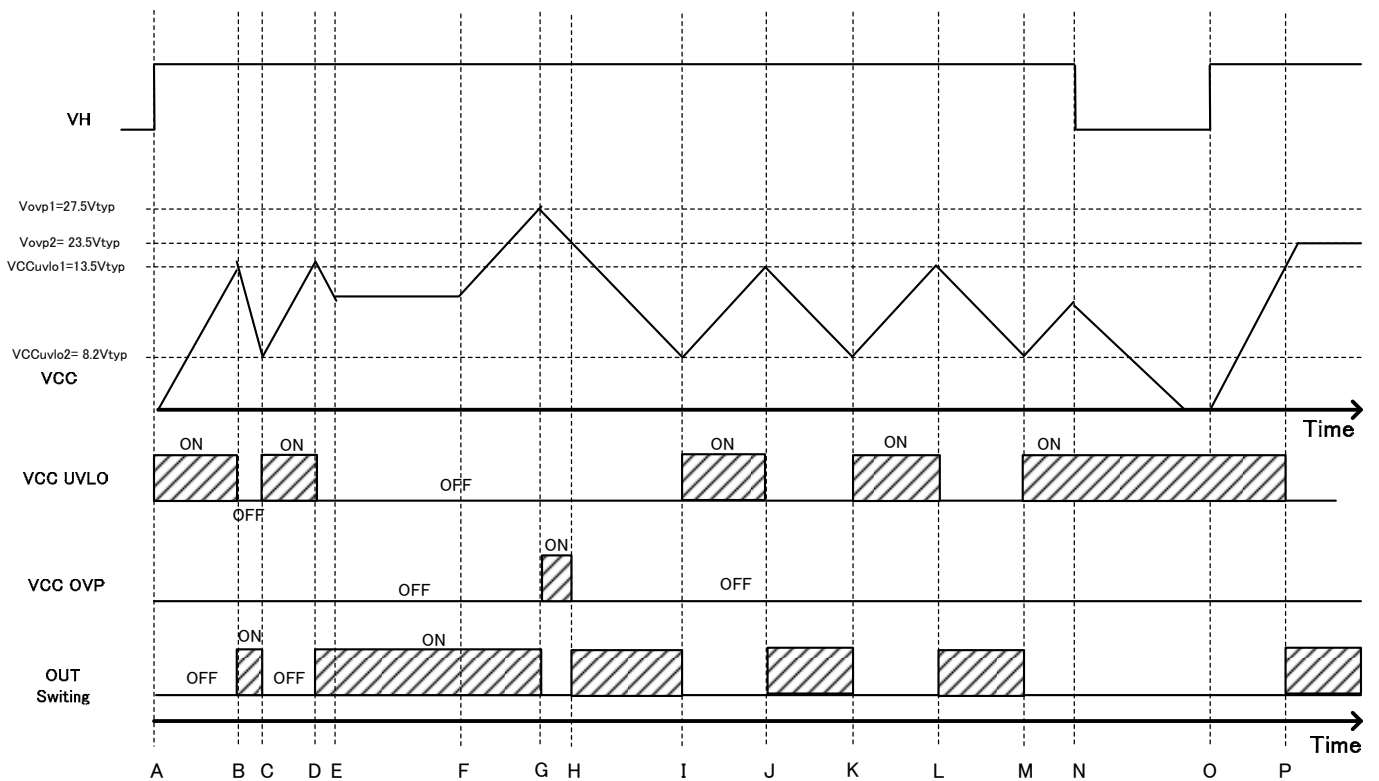

Figure 11. VCC UVLO / OVP Time Chart

- A: Voltage is applied to the VH pin (pin 8) and voltage at the VCC pin (pin 6) starts to rise.
- B: When VCC pin (pin 6) voltage >  $V_{UVLO1}$ , the VCC UVLO function is canceled and the DC/DC operation starts. Then VCC start-up circuit stops charging.
- C: When VCC pin (pin 6) voltage <  $V_{UVLO2}$ , the VCC UVLO function is operated and the DC/DC operation stops. Then VCC start-up circuit starts charging.
- D: When VCC pin (pin 6) voltage >  $V_{UVLO1}$ , the VCC UVLO function is canceled and the DC/DC operation starts. Then VCC start-up circuit stops charging.
- E: After finishing start-up, VCC pin voltage is stable as secondary output voltage is stable.
- F: VCC pin voltage rises
- G: When VCC pin (pin 6) voltage >  $V_{OCP}$  status continues for  $T_{LATCH}$  (typ = 100us), switching operation is stopped by the VCC OVP function.
- H: When VCC pin voltage <  $V_{OVP2}$ , VCCOVP function is released, and the switching operation re-starts.
- I: When VCC pin voltage <  $V_{UVLO2}$ , VCCUVLO function operates, and switching operation stops.
- J: When VCC pin (pin 6) voltage >  $V_{UVLO1}$ , the VCC UVLO function is canceled and the DC/DC operation starts.
- K: The same as I.
- L: The same as J.
- M: The same as K.
- N: High voltage line VH is reduced. Then VCC pin voltage drops because IC cannot charge the power to VCC pin.
- O: When  $VCC < V_{UVLO2}$ , the VCC UVLO function operates.
- P: When  $VCC > V_{UVLO}$ , start-up circuit stops, and the switching operation re-starts.

• Capacitance value of VCC pin

To ensure stable operation of the IC, set the VCC pin capacitance value to 10 uF or above.

If the capacitor for the VCC pin is too large, it will delay the response of the VCC pin to secondary output. In cases where the transformer has a low degree of coupling, a large surge can be generated at the VCC pin, which may damage the IC. In such cases, insert a resistance of 10 Ω to 100 Ω on a bus between the diode and capacitor after the auxiliary winding. As for constants, perform a waveform evaluation of the VCC pin and enter settings that will prevent any surge at the VCC pin from exceeding the absolute maximum rating for the VCC pin.

• VCC OVP voltage protection settings for increased secondary output

The VCC pin voltage is determined by the secondary output and the transformer ratio ( $N_p:N_s$ ). Accordingly, when secondary output has become large, it can be protected by VCC OVP. The VCC OVP protection settings are as follows.

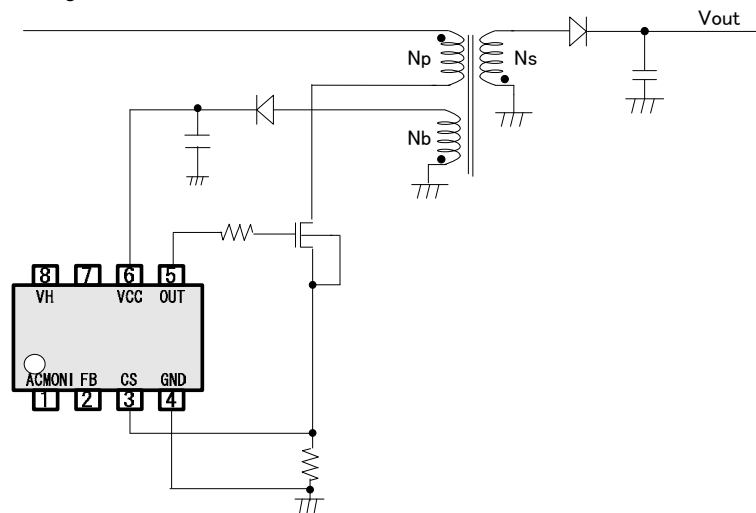

Figure 12 VCC OVP Settings

This is determined by  $VCC \text{ voltage} = V_{out} \times N_b/N_s$ .

( $V_{out}$ : Secondary output,  $N_b$ : auxiliary winding turns,  $N_s$ : secondary winding turns).

When secondary output voltage rises 30% high, and protection is desired, set the number of winding turns so that  $1.3 \times V_{out} \times (N_b/N_s) > V_{OVP1}$ .

For VCC OVP protection, since there is the  $T_{LATCH}$  (typ = 100 us) blanking time, VCC OVP protection cannot be detected for instantaneous surges at the VCC pin.

However, VCC OVP is detected when the VCC pin voltage has become higher than  $V_{OVP1}$  for at least the  $T_{LATCH}$  period, such as due to the impact of a low degree of transformer couplings, so an application evaluation should be done to check this before setting VCC OVP.

**(4) ACMONI pin protection function**

ACMONI(1pin) pin is for brown-out protection. When AC voltage falls, the brown-out function stops switching operation. The usage is shown in Figure 13. The voltage divide AC voltage by resistors is applied to ACMONI pin. When ACMONI pin voltage exceeds  $V_{ACMONI}$  (1.0V typ), IC detects normal state, and IC starts switching operation. The release condition of this function is different by DC detection and AC detection. (Fig-13 shows AC detection method) In DC detection, ACMONI pin voltage is lower than  $V_{ACMONI2}$  (0.7V typ) after switching operation, the internal timer of IC starts to operate. When the status which ACMONI pin voltage is lower than  $V_{ACMONI2}$  (0.7V typ) continues for  $T_{ACMONI1}$  (typ=256ms), the switching operation stops. In AC detection, when the status which ACMONI pin voltage is lower than  $V_{ACMONI1}$  (1.0V typ) continues for  $T_{ACMONI1}$  (typ=256ms), the switching operation stops. For that, even if AC voltage temporary disappearance occurs, the switching operation continues within  $T_{ACMONI1}$  (typ=256ms) period.

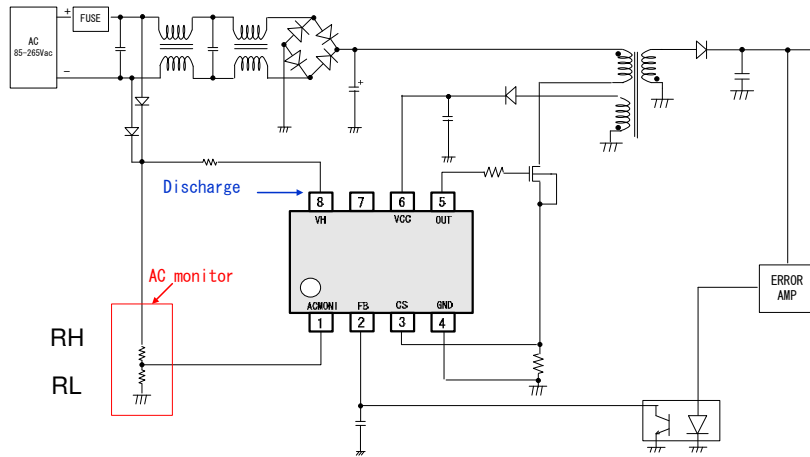

Figure 13. Application circuit

The detection value of brown-out sets by external resistors of AMMONI pin. The setting method is below:

○The setting : When AC line voltage is higher than the voltage “VHstart” , IC starts to operate  
 VHstart value is calculated by below equation.

$$VHstart = (RH + RL) / RL \times V_{ACMONI1} \quad *V_{ACMONI1} = 1.0V$$

Please set RH and RL by the equation.

Then brown-out protection voltage “VHend” is calculated by below equation.

$$VHend = (RH + RL) / RL \times V_{ACMONI2} \quad *V_{ACMONI2} = 0.7V$$

When brown-out function does not use, ACMONI pin voltage needs to be set the voltage from 1.3V to 5.0V  
 As the applied method, apply from outside or apply the voltage divided resistors from VCC.

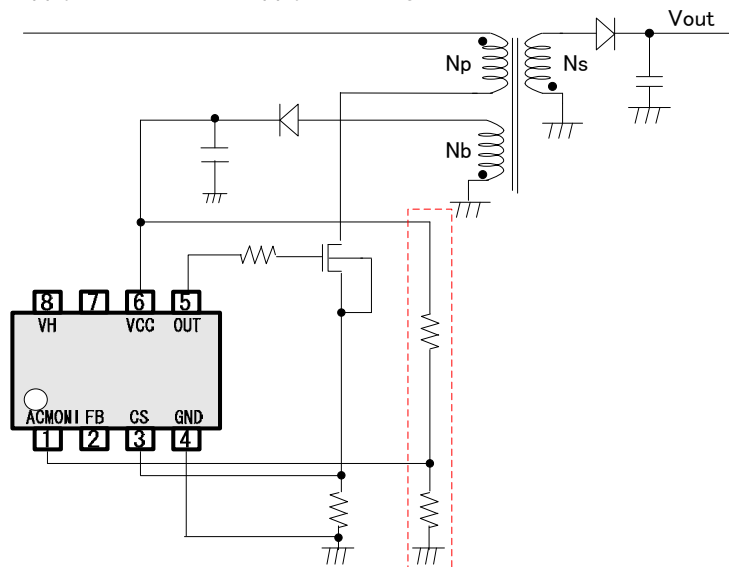

Figure 14. The setting of ACMONI pin in the case not to use brown-out function

(5) DC/DC driver (PWM comparator, frequency hopping, slope compensation, OSC, burst)

(5-1) PWM basic operations

Figure 15 shows a PWM basic block diagram and Figure 16 illustrates PWM basic operations.

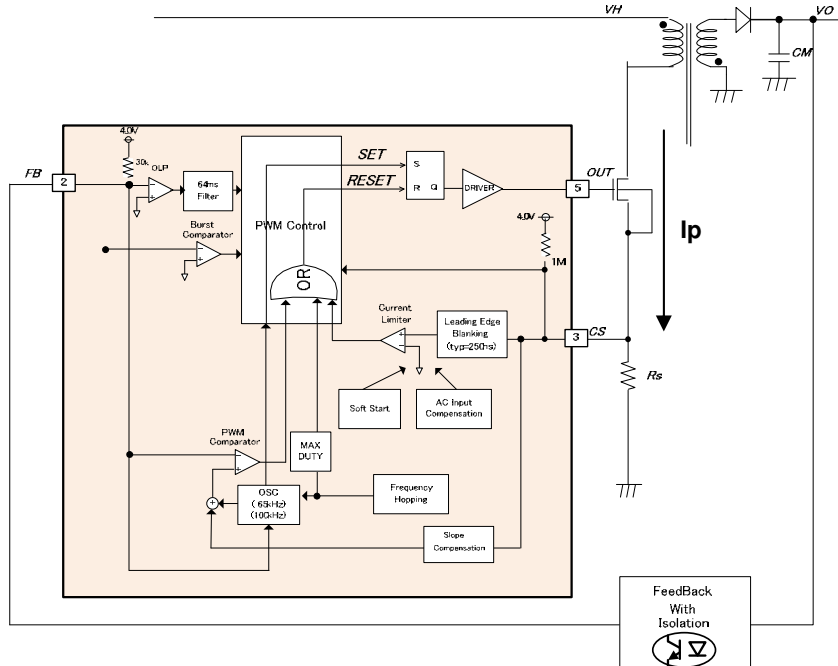

Figure 15. Block Diagram of IC Internal PWM Operations

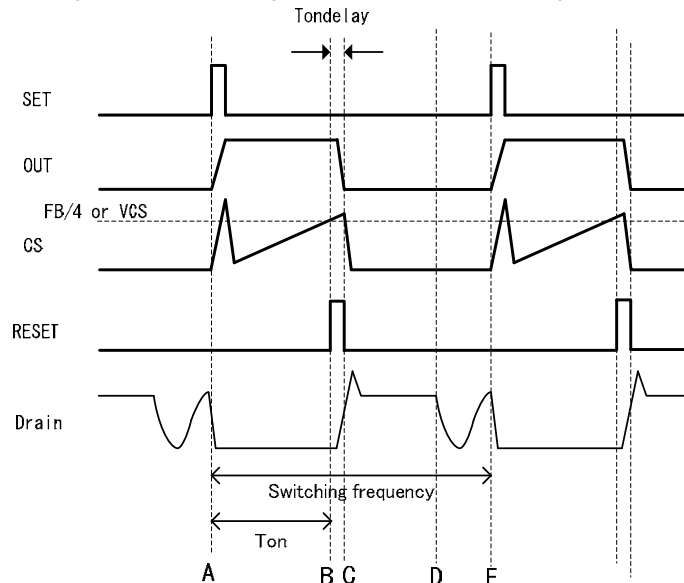

Figure 16. PWM Basic Operations

- A: A SET signal is output from the oscillator in the IC, and the MOSFET is turned ON. At that time, the capacitance between the MOSFET drain and source becomes discharged, and noise is generated at the CS pin. This noise is called the leading edge. This IC has a built-in filter for this noise. (See (6).) As a result of this filter and delay time, the minimum pulse width of the IC is 400 ns (typ). Afterward, current flow to the MOSFET and the  $V_{cs} = R_s \cdot I_p$  voltage is applied to the CS pin.
- B: When CS pin voltage rises greater than the FB pin voltage/Gain (typ = 4) or the overcurrent detection voltage  $V_{cs}$ , the RESET signal is output and OUT is turned off.
- C: There is a delay time  $T_{ondelay}$  between time point B and actual turn-off. This time results from differences in maximum power that occur based on the AC voltage. This IC includes a function that suppresses these differences. (See (5-4).)
- D: The energy that accumulates in the transformer during  $T_{on}$  status is discharged to the secondary side, and the drain voltage starts to oscillate freely based on the transformer  $L_p$  value and the MOSFET  $C_{ds}$  (drain-source capacitance).

E: Since the switching frequency within the IC is predetermined, SET signal output from the internal oscillator occurs for a set period starting from point A, and the MOSFET is turned on.

(5-2) Frequency operations

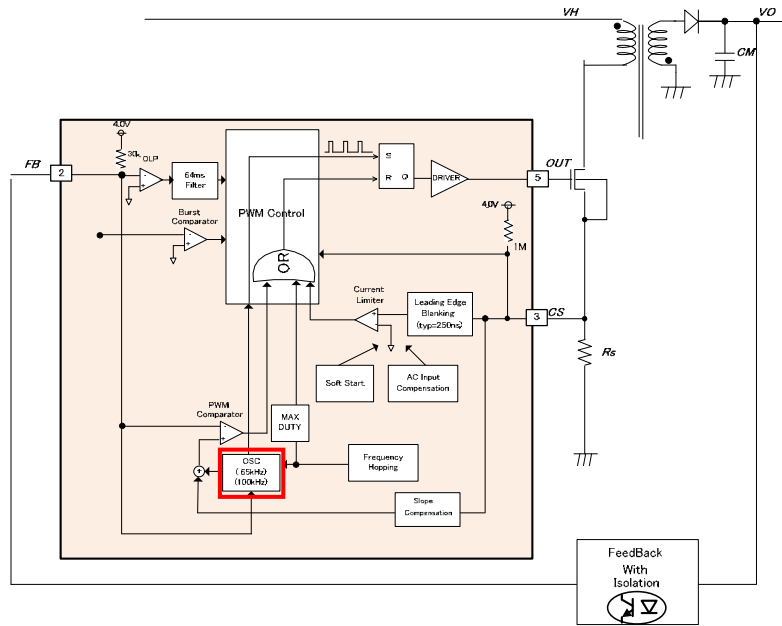

Figure 17. PWM Operations in IC

The PWM frequency is generated by the OSC block (internal oscillator) in Figure 17.

This oscillator has a switching frequency hopping function and the switching frequency fluctuates such as is shown in Figure 18.

The fluctuation cycle is 125 Hz. Due to this frequency hopping function, the frequency spectrum is dispersed and the frequency spectrum peak is lowered. This increases the margin for EMI testing.

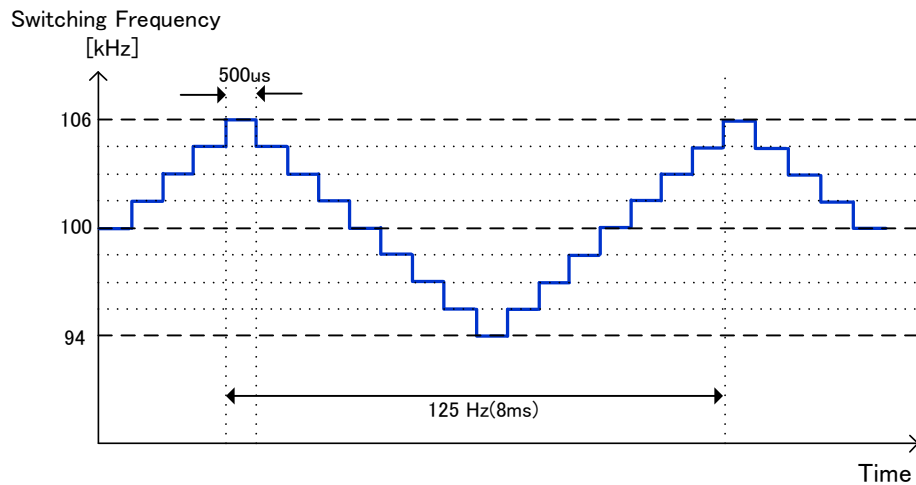

Figure 18. Frequency Hopping Function

In Figure 18, the duty is calculated as  $T_{on} \times \text{Switching frequency} \times 100$ . The maximum duty value is  $D_{max}$  (typ = 75%).

Since the PWM current mode method is being used, if the duty exceeds 50% sub harmonic oscillation may occur. 22 mV/us slope compensation is built in as a countermeasure to this.

To reduce power consumption when there is a light load, a burst mode circuit and frequency reduction circuit are built in. These operations are illustrated in Figure 19. As shown in this figure, frequency fluctuates according to the FB voltage. If the FB voltage is in the range shown for mode 2, switching loss is reduced by reducing internal oscillations based on the FB voltage.

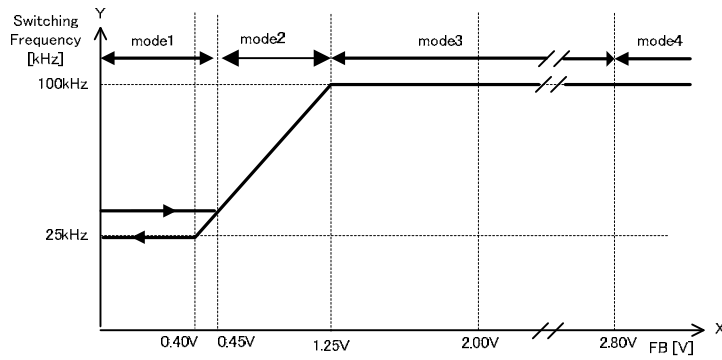

Figure 19. Operation with FB pin voltage

- mode1: Burst operation
- mode2: Frequency reduction operation (reduces maximum frequency.)
- mode3: Fixed frequency operation (operates at maximum frequency.)
- mode4: Overload operation (overload status is detected and pulse operation is stopped.)

**(5-3) Overcurrent detection operation**

$R_{FB}$  (30 kΩ.typ) is used as pull-up resistance for the FB pin with regard to the internal power supply (4.0 V).

When the load of the secondary output voltage (secondary load power) changes, the photo-coupler current changes, and so the FB pin voltage also changes.

FB voltage  $V_{FB}$  is determined by the equation FB voltage = 4 V -  $I_{FB}$ . ( $I_{FB}$ : photo coupler current)

For example, when the load becomes heavier, the FB current is reduced, so the FB voltage rises.

When the load becomes lighter, the FB current is increased, so the FB voltage drops.

In this way, secondary voltage is monitored by the FB pin.

As the FB pin voltage is monitored, if the load becomes lighter (if FB voltage drops), a burst mode operation or frequency reduction operation is executed.

Figure 20 shows the CS detection voltage with regard to FB voltage.

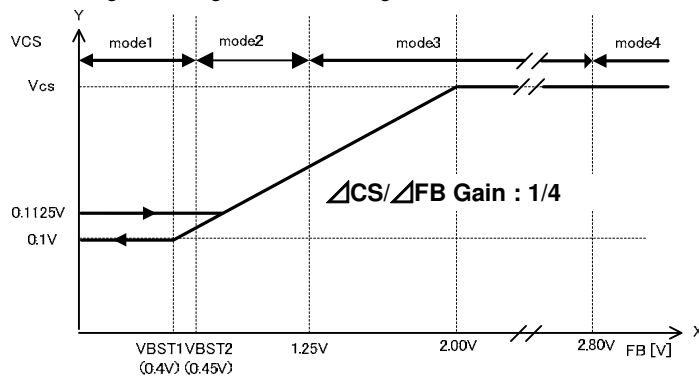

Figure 20 FB Voltage vs CS Voltage Characteristics

When FB voltage is less than 2.0 V or when the CS voltage exceeds the FB voltage / Gain (typ = 4), the MOSFET is turned off.

(See time point C in Figure 16.)

When the FB voltage exceeds 2.0 V, the CS voltage =  $V_{cs} + K_{cs} \cdot T_{on}$ .  $K_{cs} \cdot T_{on}$  depends on AC voltage compensation.

(See 5-4.)

Therefore, peak current  $I_p$  is determined as  $I_p = V_{cs1} / R_s$ .

The current value for the MOSFET should be set with a margin with regard to the  $I_p$  value obtained from this formula.

Maximum power is determined as  $P_{max} = 1/2 \times I_p \times I_p^2 \times f_{sw}$ . ( $I_p$ : primary inductance value,  $I_p$ : primary peak current,  $f_{sw}$ : switching frequency)

$V_{cs1}$  is determined as  $V_{cs1} = V_{cs} (typ = 0.4 V) + K_{cs} (typ = 20) \cdot T_{on} + V_{delay}$ .

$V_{delay}$  is the amount of CS voltage increase during the delay time  $R_{ondelay}$  between B and C in Figure 16.

This is calculated as  $V_{delay} = V_{in} / L_p \cdot T_{ondelay} \cdot R_s$ .

**(5-4) AC voltage dependent compensation of overcurrent limiter**

This IC has an AC voltage compensation function on chip. This function performs compensation for AC voltage by increasing the level of the overcurrent limiter over time. In the equation below, (A) and (B) are assigned values similar to those for AC 100 V and AC 200 V to perform compensation.

$$V_{cs1} = V_{cs} (\text{typ} = 0.4 \text{ V}) + \frac{K_{cs} (\text{typ} = 20) * T_{on}}{(A)} + \frac{V_{delay}}{(B)}$$

These operations are shown in Figures 21, 22, and 23.

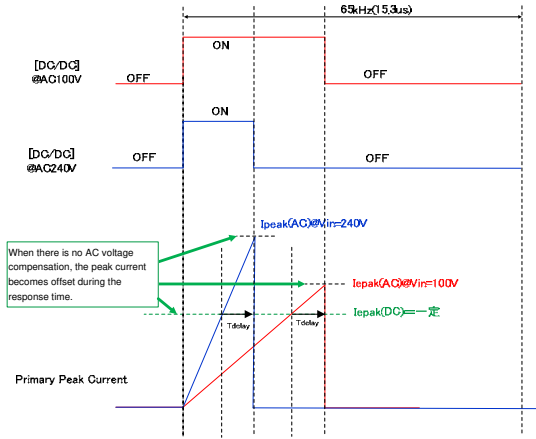

Figure 21. Without AC Voltage Compensation Function

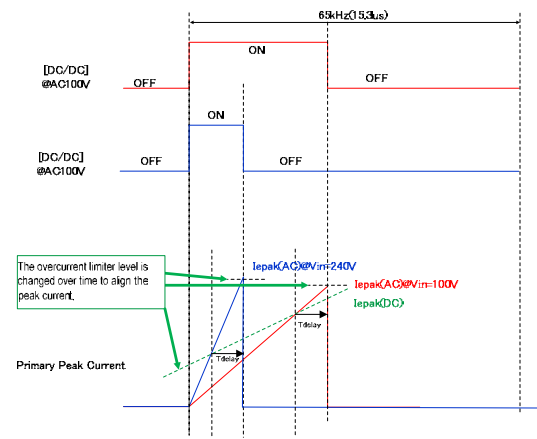

Figure 22. With AC Voltage Compensation Function

Primary peak current that flows during overload mode is defined as follows.

Primary peak current  $I_{peak} = V_{cs}/R_s + K_{cs} * T_{on}/R_s + V_{in}/L_p * T_{ondelay}$

$V_{cs}$ : Overcurrent limiter voltage in IC

$R_s$ : Current detection resistor

$V_{in}$ : Input DC voltage

$L_p$ : Primary peak current

$T_{ondelay}$ : Delay time after overcurrent limiter detection

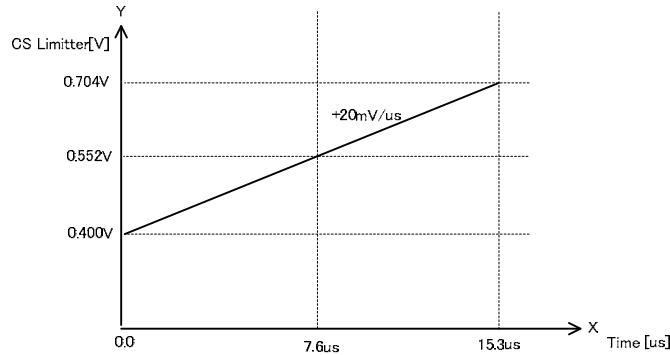

Figure 23. Overcurrent Limiter Voltage

**(6) L.E.B period**

When the driver MOSFET is turned on, a surge current is generated at time point A in Figure 16. At that time, the CS voltage (pin 4) rises, which may cause detection errors in the overcurrent limiter circuit.

To prevent these detection errors, the OUT pin in this IC is switched from low to high and the CS voltage (pin 4) is masked for 250 ns by the built-in L.E.B function (Leading Edge Blanking function). This blanking function can reduce the CS pin noise filter for the noise that is generated when switching the OUT pin from low to high.

However, if the CS pin noise does not stay within this 250 ns period, an RC filter should be applied to this pin, such as is shown in Figure 24. At this time, a delay time occurs due to the RC filter when the CS pin is detected. Even if there is no filter, attachment of  $R_{CS}$  as a surge countermeasure is recommended.

The recommended resistance for  $R_{CS}$  is 1 k $\Omega$ . When a filter ring is desired, use  $C_{CS}$  to adjust for this resistance.

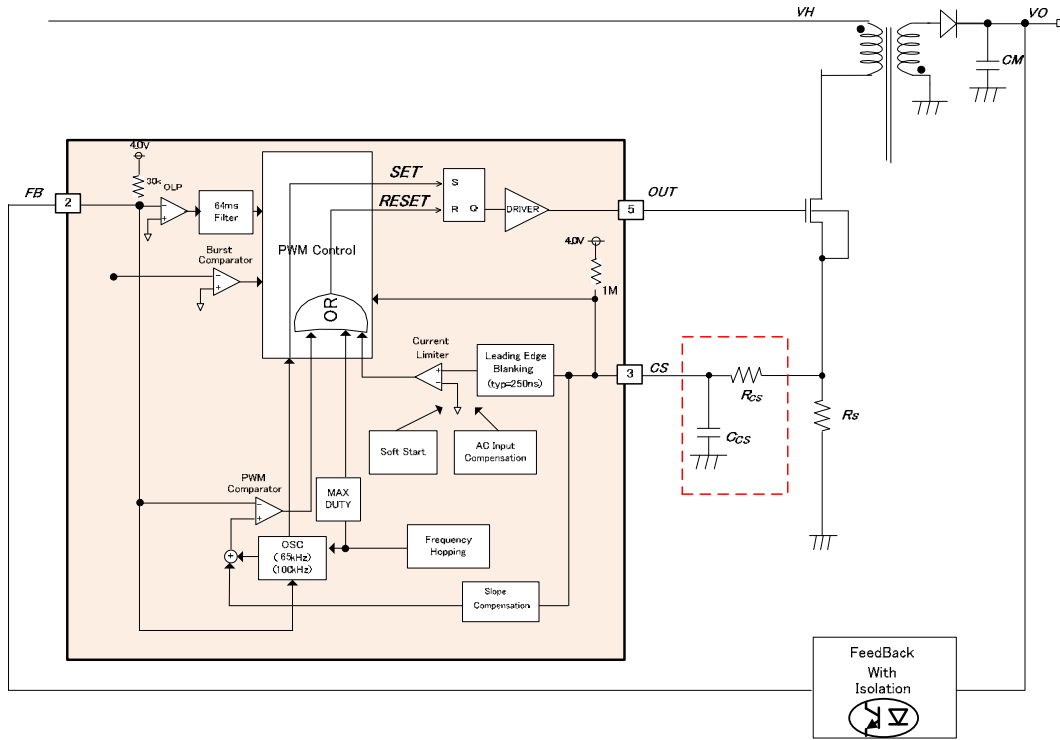

Figure24. Circuits Peripheral to the CS Pin

**(7) CS pin open protection**

When the CS pin (pin 4) has become an open pin, transient heat (due to noise, etc.) occurs in the IC, which may become damaged.

An open protection circuit has been built in to prevent such damage. (Auto recovery protection)

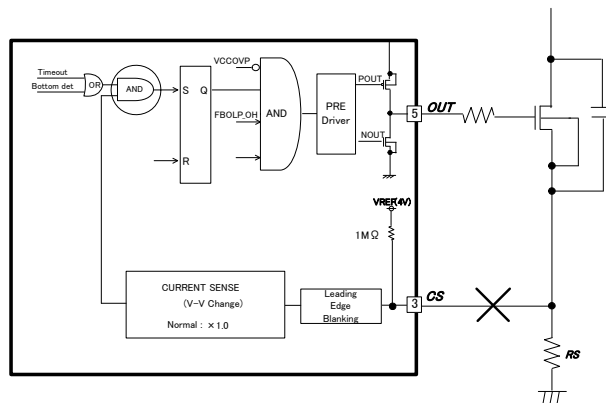

Figure 25. CS Pin Peripheral Circuit



**(8) Output overload protection function (FB OLP comparator)**

As is shown in mode4 of Figure 20, when the FB pin voltage rises to above a certain value, it is called an overload condition.

The output overload protection function stops switching operations when mode4 has an overload condition.

During an overload condition, the output voltage drops and so current no longer flows to the photo coupler while the FB voltage (pin 2) rises.

When the FB voltage (pin 2) exceeds  $V_{FOLP1A}$  (2.8 V typ) continuously for  $T_{FOLP2}$  (64 ms typ), it is judged as an overload condition and switching is stopped.

While the FB pin (pin 2) exceeds  $V_{FOLP1A}$  (2.8 V typ), if the FB pin (pin 2) voltage drops below  $V_{FOLP1B}$  (2.6 V typ) during the  $T_{FOLP}$  (64 ms typ) period, the overload protection timer is reset. Switching operation are performed during the  $T_{FOLP}$  (64 ms typ) period. At startup, the FB pin (pin 2) voltage is pulled up by a resistance to the IC internal voltage, and operations start when the voltage reaches  $V_{FOLP1A}$  (2.8 V typ) or above. Therefore, at startup the start time of secondary output voltage must be set so that the FB voltage (pin 2) drops to  $V_{FOLP1B}$  (2.6 V typ) or below within the  $T_{FOLP}$  (64 ms typ) period. Once FBOLP is detected, the switching operation stops, and VCC voltage falls down because secondary output voltage falls down. When VCC voltage is lower than  $V_{UVLO2}$ (8.2V.typ), IC is reset, and IC starts by starter circuit shown in (1).

The switching stop time is calculated by VCC pin voltage and VCC capacitor and Icc current

$$\text{Stop time : } T_{\text{stop}} \quad T_{\text{stop}} = C_{\text{vcc}} * (V_{\text{CC}} - V_{\text{UVLO2}}) / I_{\text{CC}}$$

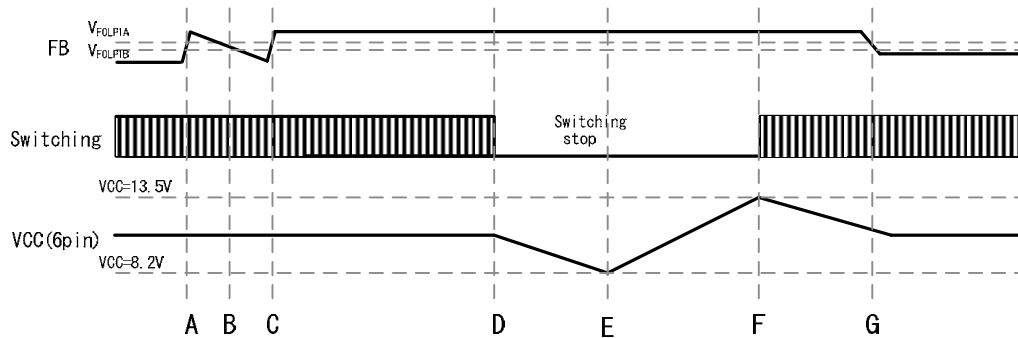

Figure 26. Overload Protection (Auto Recovery)

- A: Since  $FB > V_{FOLP1A}$ , the FBOLP comparator detects an overload.
- B: When  $FB < V_{FOLP1B}$  within  $T_{FOLP}$  (typ=64ms) period, FB overload detection is released, and FBOLP timer is reset.
- C: Since  $FB > V_{FOLP1A}$ , the FBOLP comparator detects an overload.
- D: When the condition at C continues for  $T_{FOLP}$  (typ = 64 ms), switching is stopped by the overload protection function. As switching operation stops, VCC pin voltage falls down because output voltage falls down.
- E: When  $V_{CC} \text{ pin voltage} < V_{UVLO2}$ , IC is reset by VCC UVLO function, and start-up circuit operates.
- F: When  $V_{CC} \text{ pin voltage} > V_{UVLO1}$ , VCC UVLO is released, and switching operation starts.
- G: Because secondary output voltage is stable, VCC pin voltage is also stable.

**(9-1) OUT pin clamp function**

To protect the external MOSFET, the high voltage level of the OUT pin (pin 5) is clamped to  $V_{OUTH}$  (typ = 12.5 V). The VCC pin (pin 6) voltage is raised to prevent MOSFET gate damage. (Shown in Figure27.)

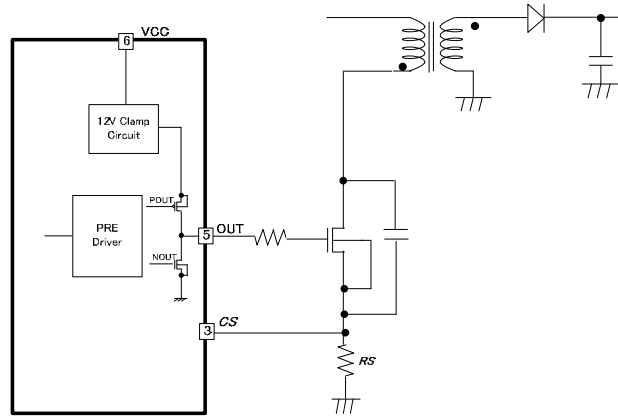

Figure 27. OUT Pin (Pin 5) Schematic

**(9-2) OUT pin driver circuit**

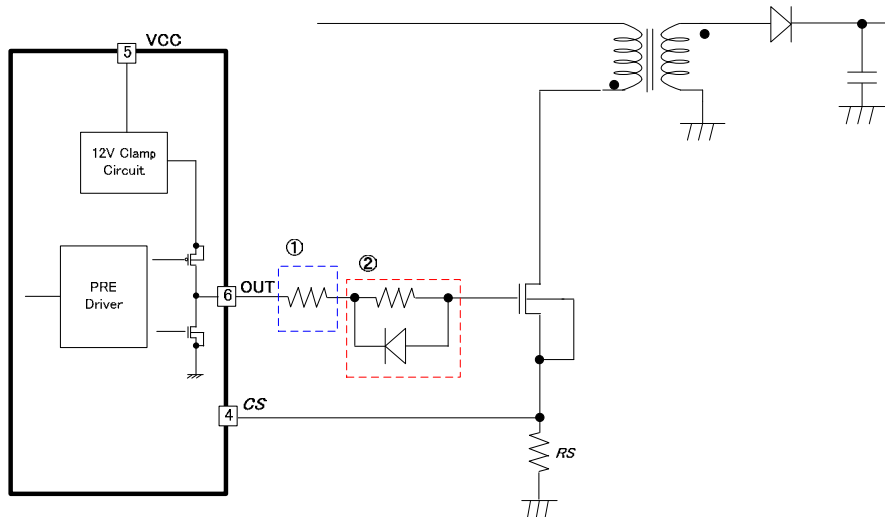

Figure 28. OUT Pin (Pin 5) Driver Circuit

Switching noise that occurs when OUT is turned on or off may cause EMI-related problems.

In such cases, the MOSFET turn-on time and turn-off time must be delayed.

However, when the turn off time is delayed, switching loss increases.

Figure 28 shows a delay circuit for the OUT pin. In Figure 28, ① is valid during both turn-on and turn-off operations.

② shows a delay in the turn-on only, while turn-off is accelerated.

(10) Caution points for board layout pattern

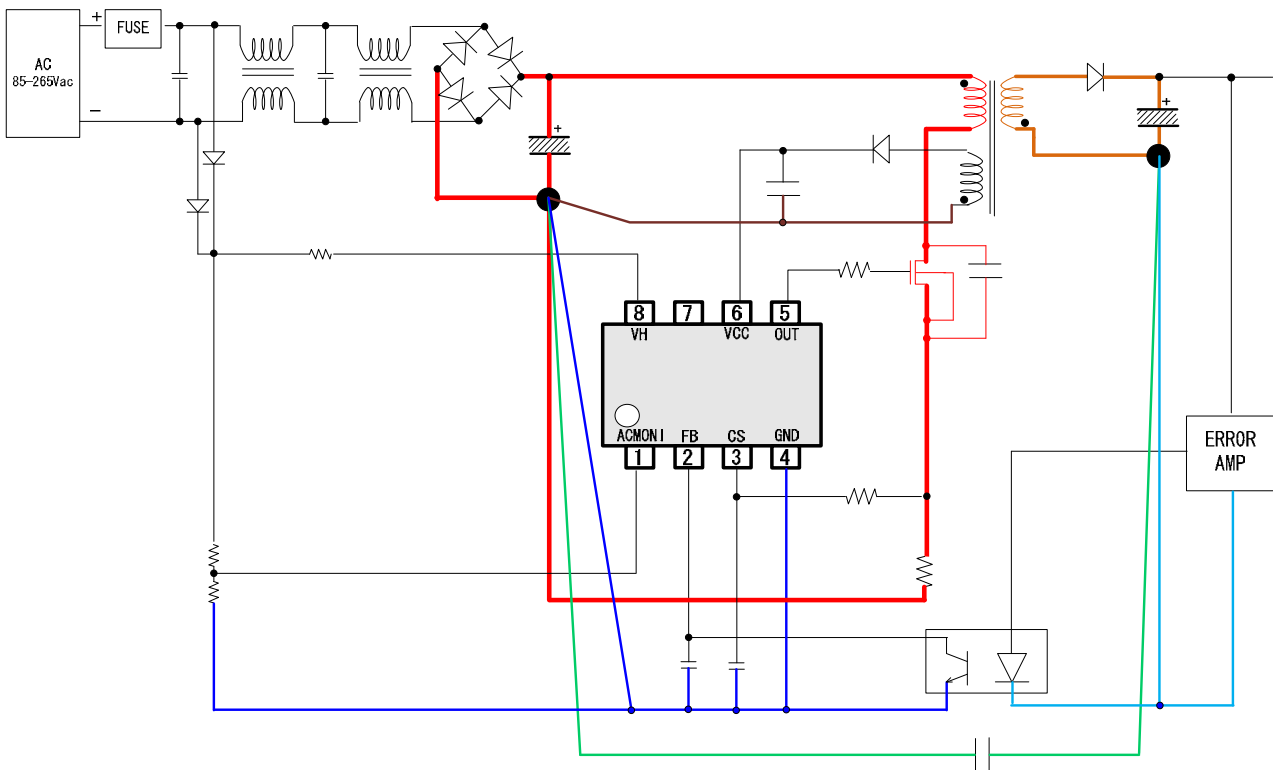

Figure 29. Board Layout Pattern

• Caution points

- ① The red lines shown in Figure 29 are large current pathways. In the layout, these should be as short as possible since they can cause ringing, dissipation, etc. Also, any loops that occur in the red line should be made as small as possible in this layout.
- ② The orange lines in the secondary side of Figure 29 should also be made short and thick like the red lines and should be made with small loops in this layout.
- ③ Be sure to implement grounding for the red lines, brown lines, blue lines, and green lines.
- ④ The green lines are pathways for surges on the secondary side to escape to the primary side, and since a large current may flow instantaneously, they should be laid out independently of the red lines and blue lines.
- ⑤ The blue lines are GND lines for IC control. They do not have any large current flow, but they are susceptible to noise effects, so they should be laid out independently of the red lines, green lines, and brown lines.
- ⑥ The brown lines are current pathways for the VCC pin. A current flows on these lines during switching, so they should also be laid out independently.
- ⑦ Do not route any IC control lines directly under the transformer, since they may be affected by magnetic flux.

(Application circuit example)

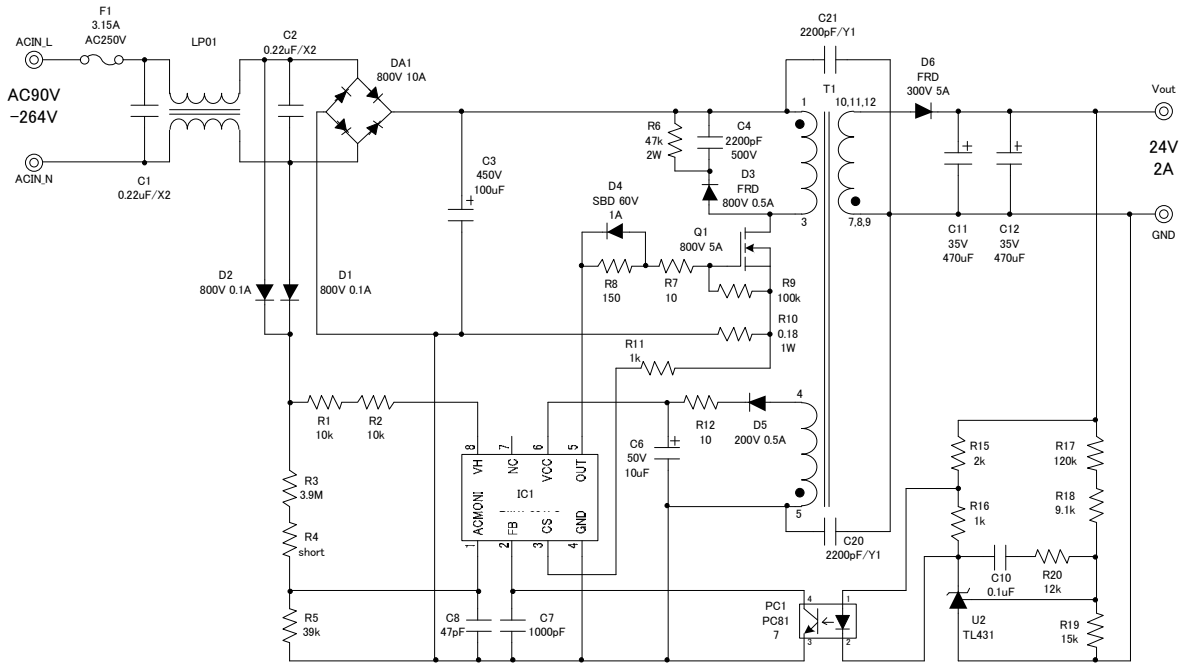

Figure 30. Application Circuit Example

• **Operation modes of protection circuit**

Table 3 lists the operation mode of each protection function.

Table 3. Operation Modes of Protection Circuit

Function	Operation mode
VCC Undervoltage Locked Out	Auto recovery
VCC Overvoltage Protection	Auto recovery (with 100- $\mu$ s timer)
FB Over Limited Protection	Auto recovery (with 64- $\mu$ s timer)
CS OPEN Protection	Auto recovery (with 100- $\mu$ s timer)

• **Sequence**

The sequence for this IC is shown in Figure 31.

A transition to OFF mode occurs under all conditions when VCC exceeds 8.2 V.

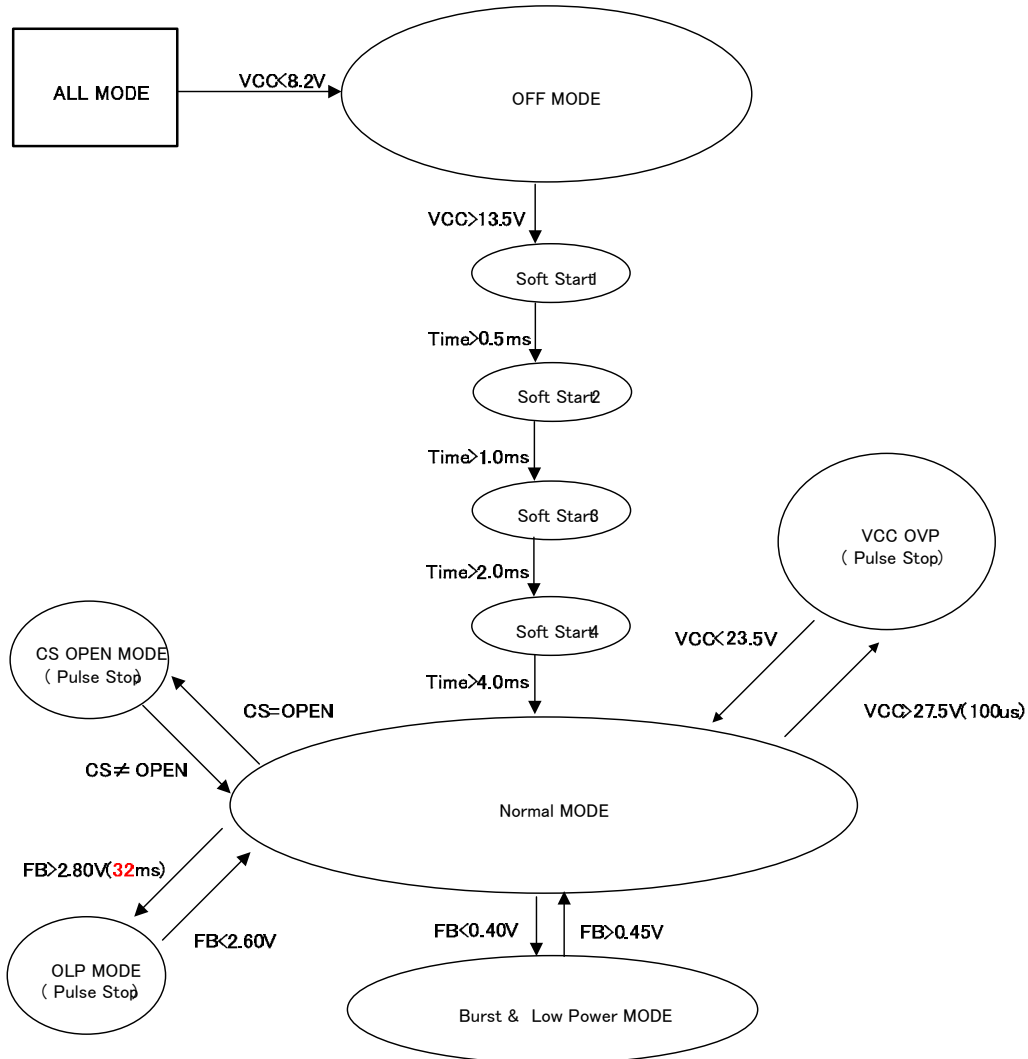

Figure 31. Sequence Diagram

• Thermal loss

In the thermal design, set operations for the following conditions.

(The temperature shown below is the guaranteed temperature, so be sure that a margin is taken into account.)

1. Ambient temperature  $T_a$  must be 85°C or less.
2. IC loss must be within the allowable dissipation  $P_d$ .

The thermal abatement characteristics are follows. (PCB: 70 mm x 70 mm x 1.6 mm, when mounted on glass epoxy substrate)

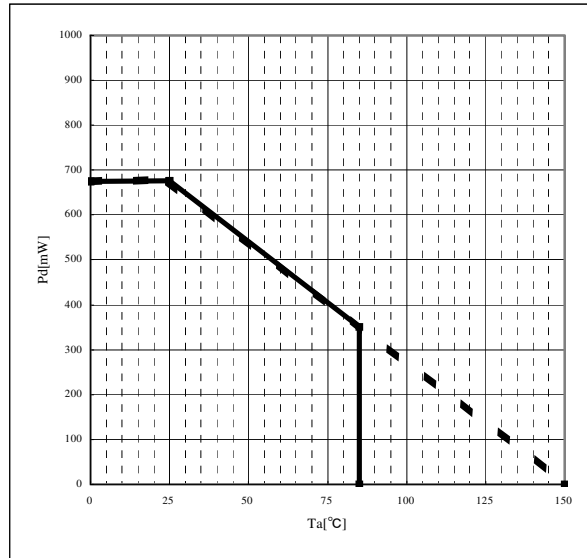

Figure 32. Thermal Abatement Characteristics

## Operational Notes

### 1. Reverse Connection of Power Supply

Connecting the power supply in reverse polarity can damage the IC. Take precautions against reverse polarity when connecting the power supply, such as mounting an external diode between the power supply and the IC's power supply pins.

### 2. Power Supply Lines

Design the PCB layout pattern to provide low impedance supply lines. Separate the ground and supply lines of the digital and analog blocks to prevent noise in the ground and supply lines of the digital block from affecting the analog block. Furthermore, connect a capacitor to ground at all power supply pins. Consider the effect of temperature and aging on the capacitance value when using electrolytic capacitors.

### 3. Ground Voltage

Ensure that no pins are at a voltage below that of the ground pin at any time, even during transient condition.

### 4. Ground Wiring Pattern

When using both small-signal and large-current ground traces, the two ground traces should be routed separately but connected to a single ground at the reference point of the application board to avoid fluctuations in the small-signal ground caused by large currents. Also ensure that the ground traces of external components do not cause variations on the ground voltage. The ground lines must be as short and thick as possible to reduce line impedance.

### 5. Thermal Consideration

Should by any chance the power dissipation rating be exceeded the rise in temperature of the chip may result in deterioration of the properties of the chip. The absolute maximum rating of the Pd stated in this specification is when the IC is mounted on a 70mm x 70mm x 1.6mm glass epoxy board. In case of exceeding this absolute maximum rating, increase the board size and copper area to prevent exceeding the Pd rating.

### 6. Recommended Operating Conditions

These conditions represent a range within which the expected characteristics of the IC can be approximately obtained. The electrical characteristics are guaranteed under the conditions of each parameter.

### 7. Inrush Current

When power is first supplied to the IC, it is possible that the internal logic may be unstable and inrush current may flow instantaneously due to the internal powering sequence and delays, especially if the IC has more than one power supply. Therefore, give special consideration to power coupling capacitance, power wiring, width of ground wiring, and routing of connections.

### 8. Operation Under Strong Electromagnetic Field

Operating the IC in the presence of a strong electromagnetic field may cause the IC to malfunction.

### 9. Testing on Application Boards

When testing the IC on an application board, connecting a capacitor directly to a low-impedance output pin may subject the IC to stress. Always discharge capacitors completely after each process or step. The IC's power supply should always be turned off completely before connecting or removing it from the test setup during the inspection process. To prevent damage from static discharge, ground the IC during assembly and use similar precautions during transport and storage.

### 10. Inter-pin Short and Mounting Errors

Ensure that the direction and position are correct when mounting the IC on the PCB. Incorrect mounting may result in damaging the IC. Avoid nearby pins being shorted to each other especially to ground, power supply and output pin. Inter-pin shorts could be due to many reasons such as metal particles, water droplets (in very humid environment) and unintentional solder bridge deposited in between pins during assembly to name a few.

Operational Notes – continued

11. Unused Input Pins

Input pins of an IC are often connected to the gate of a MOS transistor. The gate has extremely high impedance and extremely low capacitance. If left unconnected, the electric field from the outside can easily charge it. The small charge acquired in this way is enough to produce a significant effect on the conduction through the transistor and cause unexpected operation of the IC. So unless otherwise specified, unused input pins should be connected to the power supply or ground line.

12. Regarding the Input Pin of the IC

This monolithic IC contains P+ isolation and P substrate layers between adjacent elements in order to keep them isolated. P-N junctions are formed at the intersection of the P layers with the N layers of other elements, creating a parasitic diode or transistor. For example (refer to figure below):

When GND > Pin A and GND > Pin B, the P-N junction operates as a parasitic diode.  
 When GND > Pin B, the P-N junction operates as a parasitic transistor.

Parasitic diodes inevitably occur in the structure of the IC. The operation of parasitic diodes can result in mutual interference among circuits, operational faults, or physical damage. Therefore, conditions that cause these diodes to operate, such as applying a voltage lower than the GND voltage to an input pin (and thus to the P substrate) should be avoided.

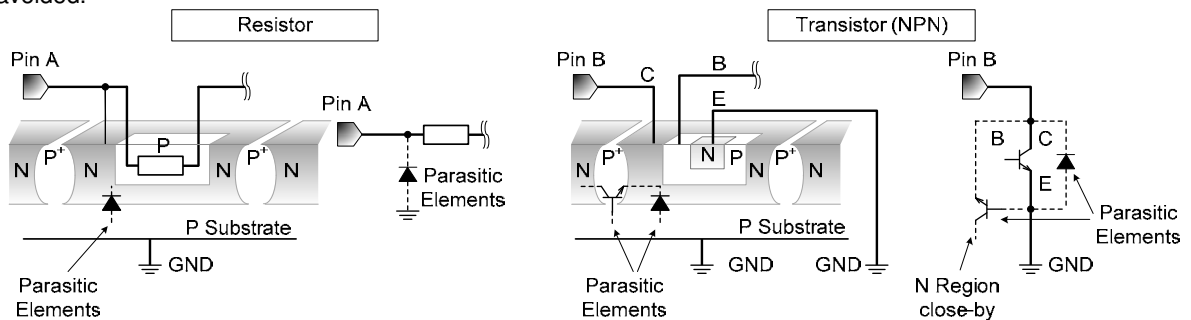

Figure 31. Example of monolithic IC structure

13. Ceramic Capacitor

When using a ceramic capacitor, determine the dielectric constant considering the change of capacitance with temperature and the decrease in nominal capacitance due to DC bias and others.

14. Area of Safe Operation (ASO)

Operate the IC such that the output voltage, output current, and power dissipation are all within the Area of Safe Operation (ASO).

15. Thermal Shutdown Circuit(TSD)

This IC has a built-in thermal shutdown circuit that prevents heat damage to the IC. Normal operation should always be within the IC's power dissipation rating. If however the rating is exceeded for a continued period, the junction temperature (Tj) will rise which will activate the TSD circuit that will turn OFF all output pins. When the Tj falls below the TSD threshold, the circuits are automatically restored to normal operation.

Note that the TSD circuit operates in a situation that exceeds the absolute maximum ratings and therefore, under no circumstances, should the TSD circuit be used in a set design or for any purpose other than protecting the IC from heat damage.

16. Over Current Protection Circuit (OCP)

This IC incorporates an integrated overcurrent protection circuit that is activated when the load is shorted. This protection circuit is effective in preventing damage due to sudden and unexpected incidents. However, the IC should not be used in applications characterized by continuous operation or transitioning of the protection circuit.



● Part Number selection

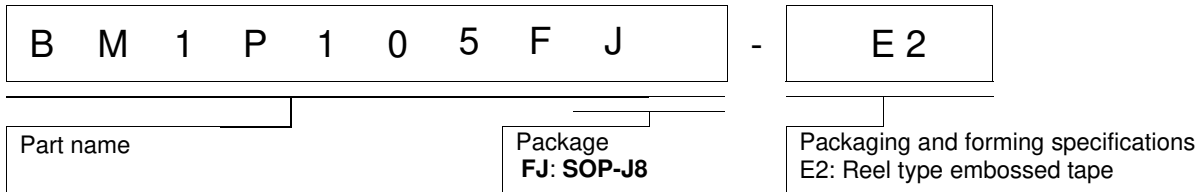

● Marking diagram

● Line-up

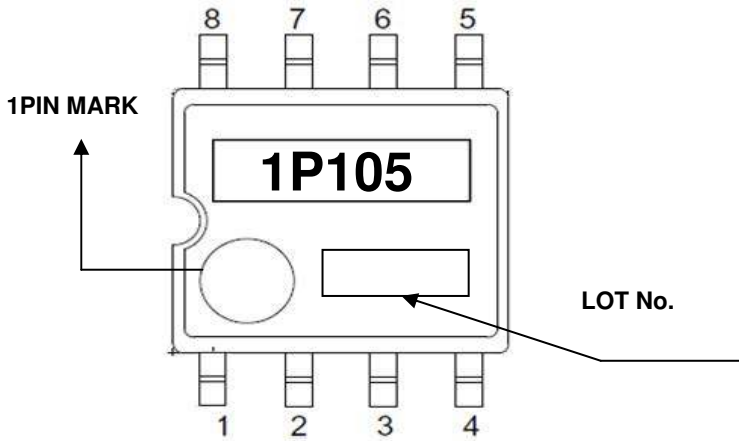

Model name (BM1PXXXFJ)
BM1P061FJ
BM1P062FJ
BM1P063FJ
BM1P064FJ
BM1P065FJ
BM1P066FJ
BM1P067FJ
BM1P068FJ
BM1P101FJ
BM1P102FJ
BM1P103FJ
BM1P104FJ
BM1P105FJ
BM1P106FJ
BM1P107FJ
BM1P108FJ

Physical Dimension, Tape and Reel Information

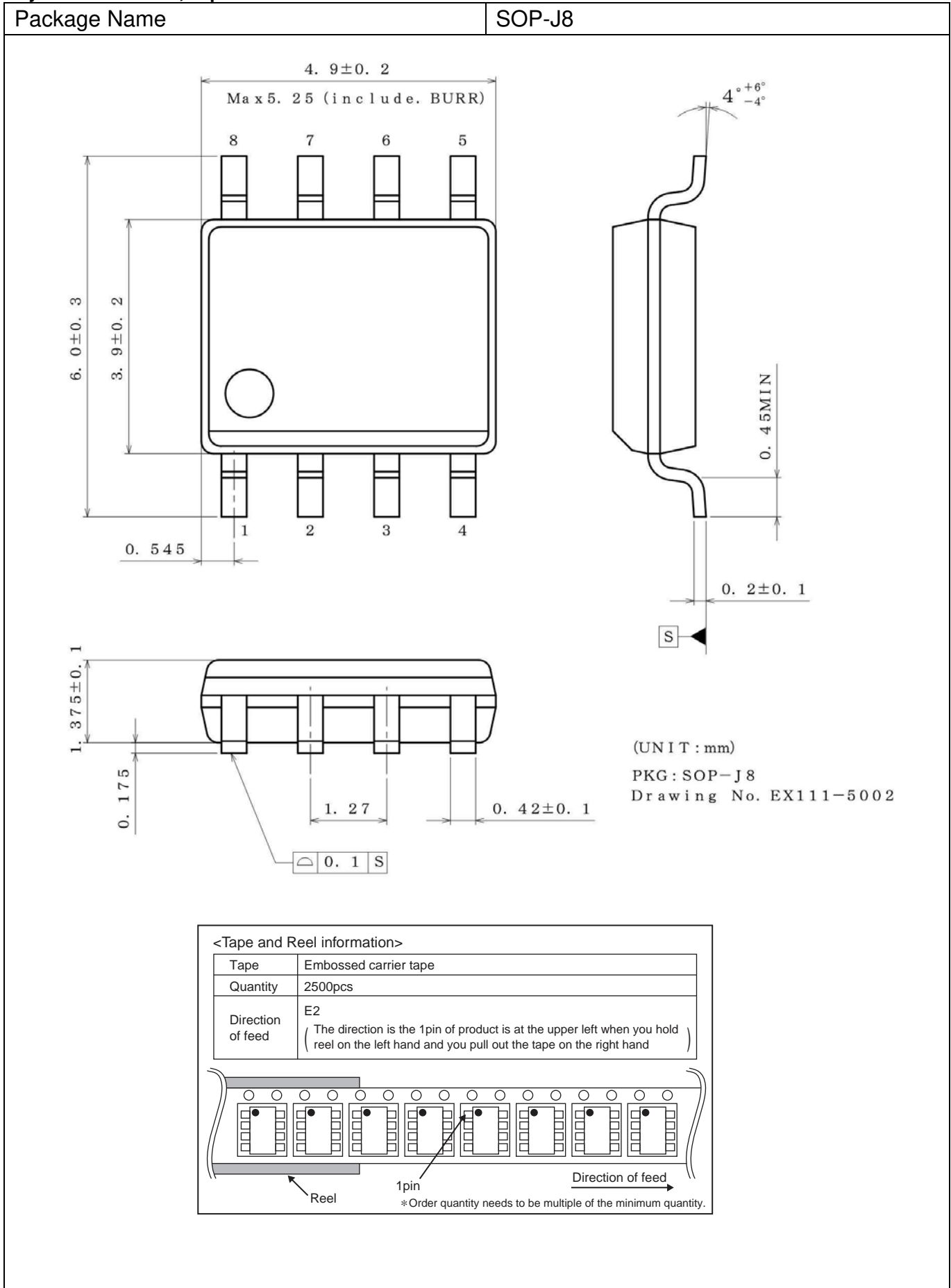

## Revision History

Date	Revision	Changes
20.Jan.2014	001	New Release

# Notice

## Precaution on using ROHM Products

- Our Products are designed and manufactured for application in ordinary electronic equipments (such as AV equipment, OA equipment, telecommunication equipment, home electronic appliances, amusement equipment, etc.). If you intend to use our Products in devices requiring extremely high reliability (such as medical equipment <sup>(Note 1)</sup>, transport equipment, traffic equipment, aircraft/spacecraft, nuclear power controllers, fuel controllers, car equipment including car accessories, safety devices, etc.) and whose malfunction or failure may cause loss of human life, bodily injury or serious damage to property ("Specific Applications"), please consult with the ROHM sales representative in advance. Unless otherwise agreed in writing by ROHM in advance, ROHM shall not be in any way responsible or liable for any damages, expenses or losses incurred by you or third parties arising from the use of any ROHM's Products for Specific Applications.

(Note1) Medical Equipment Classification of the Specific Applications

JAPAN	USA	EU	CHINA
CLASS III	CLASS III	CLASS II b	CLASS III
CLASS IV		CLASS III	

- ROHM designs and manufactures its Products subject to strict quality control system. However, semiconductor products can fail or malfunction at a certain rate. Please be sure to implement, at your own responsibilities, adequate safety measures including but not limited to fail-safe design against the physical injury, damage to any property, which a failure or malfunction of our Products may cause. The following are examples of safety measures:
  - Installation of protection circuits or other protective devices to improve system safety
  - Installation of redundant circuits to reduce the impact of single or multiple circuit failure
- Our Products are designed and manufactured for use under standard conditions and not under any special or extraordinary environments or conditions, as exemplified below. Accordingly, ROHM shall not be in any way responsible or liable for any damages, expenses or losses arising from the use of any ROHM's Products under any special or extraordinary environments or conditions. If you intend to use our Products under any special or extraordinary environments or conditions (as exemplified below), your independent verification and confirmation of product performance, reliability, etc. prior to use, must be necessary:
  - Use of our Products in any types of liquid, including water, oils, chemicals, and organic solvents
  - Use of our Products outdoors or in places where the Products are exposed to direct sunlight or dust
  - Use of our Products in places where the Products are exposed to sea wind or corrosive gases, including Cl<sub>2</sub>, H<sub>2</sub>S, NH<sub>3</sub>, SO<sub>2</sub>, and NO<sub>2</sub>
  - Use of our Products in places where the Products are exposed to static electricity or electromagnetic waves
  - Use of our Products in proximity to heat-producing components, plastic cords, or other flammable items
  - Sealing or coating our Products with resin or other coating materials
  - Use of our Products without cleaning residue of flux (even if you use no-clean type fluxes, cleaning residue of flux is recommended); or Washing our Products by using water or water-soluble cleaning agents for cleaning residue after soldering
  - Use of the Products in places subject to dew condensation
- The Products are not subject to radiation-proof design.
- Please verify and confirm characteristics of the final or mounted products in using the Products.
- In particular, if a transient load (a large amount of load applied in a short period of time, such as pulse. is applied, confirmation of performance characteristics after on-board mounting is strongly recommended. Avoid applying power exceeding normal rated power; exceeding the power rating under steady-state loading condition may negatively affect product performance and reliability.
- De-rate Power Dissipation (Pd) depending on Ambient temperature (Ta). When used in sealed area, confirm the actual ambient temperature.
- Confirm that operation temperature is within the specified range described in the product specification.
- ROHM shall not be in any way responsible or liable for failure induced under deviant condition from what is defined in this document.

## Precaution for Mounting / Circuit board design

- When a highly active halogenous (chlorine, bromine, etc.) flux is used, the residue of flux may negatively affect product performance and reliability.
- In principle, the reflow soldering method must be used; if flow soldering method is preferred, please consult with the ROHM representative in advance.

For details, please refer to ROHM Mounting specification

### Precautions Regarding Application Examples and External Circuits

1. If change is made to the constant of an external circuit, please allow a sufficient margin considering variations of the characteristics of the Products and external components, including transient characteristics, as well as static characteristics.
2. You agree that application notes, reference designs, and associated data and information contained in this document are presented only as guidance for Products use. Therefore, in case you use such information, you are solely responsible for it and you must exercise your own independent verification and judgment in the use of such information contained in this document. ROHM shall not be in any way responsible or liable for any damages, expenses or losses incurred by you or third parties arising from the use of such information.

### Precaution for Electrostatic

This Product is electrostatic sensitive product, which may be damaged due to electrostatic discharge. Please take proper caution in your manufacturing process and storage so that voltage exceeding the Products maximum rating will not be applied to Products. Please take special care under dry condition (e.g. Grounding of human body / equipment / solder iron, isolation from charged objects, setting of Ionizer, friction prevention and temperature / humidity control).

### Precaution for Storage / Transportation

1. Product performance and soldered connections may deteriorate if the Products are stored in the places where:
  - [a] the Products are exposed to sea winds or corrosive gases, including Cl<sub>2</sub>, H<sub>2</sub>S, NH<sub>3</sub>, SO<sub>2</sub>, and NO<sub>2</sub>
  - [b] the temperature or humidity exceeds those recommended by ROHM
  - [c] the Products are exposed to direct sunshine or condensation
  - [d] the Products are exposed to high Electrostatic
2. Even under ROHM recommended storage condition, solderability of products out of recommended storage time period may be degraded. It is strongly recommended to confirm solderability before using Products of which storage time is exceeding the recommended storage time period.
3. Store / transport cartons in the correct direction, which is indicated on a carton with a symbol. Otherwise bent leads may occur due to excessive stress applied when dropping of a carton.
4. Use Products within the specified time after opening a humidity barrier bag. Baking is required before using Products of which storage time is exceeding the recommended storage time period.

### Precaution for Product Label

QR code printed on ROHM Products label is for ROHM's internal use only.

### Precaution for Disposition

When disposing Products please dispose them properly using an authorized industry waste company.

### Precaution for Foreign Exchange and Foreign Trade act

Since our Products might fall under controlled goods prescribed by the applicable foreign exchange and foreign trade act, please consult with ROHM representative in case of export.

### Precaution Regarding Intellectual Property Rights

1. All information and data including but not limited to application example contained in this document is for reference only. ROHM does not warrant that foregoing information or data will not infringe any intellectual property rights or any other rights of any third party regarding such information or data. ROHM shall not be in any way responsible or liable for infringement of any intellectual property rights or other damages arising from use of such information or data.:
2. No license, expressly or implied, is granted hereby under any intellectual property rights or other rights of ROHM or any third parties with respect to the information contained in this document.

### Other Precaution

1. This document may not be reprinted or reproduced, in whole or in part, without prior written consent of ROHM.
2. The Products may not be disassembled, converted, modified, reproduced or otherwise changed without prior written consent of ROHM.
3. In no event shall you use in any way whatsoever the Products and the related technical information contained in the Products or this document for any military purposes, including but not limited to, the development of mass-destruction weapons.
4. The proper names of companies or products described in this document are trademarks or registered trademarks of ROHM, its affiliated companies or third parties.

**General Precaution**

1. Before you use our Products, you are requested to carefully read this document and fully understand its contents. ROHM shall not be in any way responsible or liable for failure, malfunction or accident arising from the use of any ROHM's Products against warning, caution or note contained in this document.
2. All information contained in this document is current as of the issuing date and subject to change without any prior notice. Before purchasing or using ROHM's Products, please confirm the latest information with a ROHM sales representative.
3. The information contained in this document is provided on an "as is" basis and ROHM does not warrant that all information contained in this document is accurate and/or error-free. ROHM shall not be in any way responsible or liable for any damages, expenses or losses incurred by you or third parties resulting from inaccuracy or errors of or concerning such information.