

### DESCRIPTION

The MP86956 is a monolithic half-bridge with built-in internal power MOSFETs and gate drivers. The MP86956 achieves 70A of continuous output current over a wide input supply range.

The MP86956 takes a monolithic IC approach that drives up to 70A of current per phase. The integration of drivers and MOSFETs results in high efficiency due to an optimal dead time and parasitic inductance reduction. The MP86956 can operate from 100kHz to 3MHz.

The MP86956 offers many features to simplify system design. The MP86956 works with controllers with a tri-state PWM signal and comes with an accurate current sense to monitor the inductor current and temperature sense to report the junction temperature.

The MP86956 is ideal for server applications where efficiency and small size are a premium. The MP86956 is available in LGA and TLGA (5mmx6mm) packages.

### FEATURES

- Wide 3V to 16V Operating Input Range
- 70A Output Current
- Current Sense: Accu-Sense™
- Temperature Sense
- Accepts Tri-State PWM Signal
- Current-Limit Protection
- Over-Temperature Protection (OTP)
- Fault Reporting
- Available in LGA and TLGA (5mmx6mm) Packages

### APPLICATIONS

- Server Core Voltage
- Graphic Card Core Regulators
- Power Modules

All MPS parts are lead-free, halogen-free, and adhere to the RoHS directive. For MPS green status, please visit the MPS website under Quality Assurance. "MPS", the MPS logo, and "Simple, Easy Solutions" are trademarks of Monolithic Power Systems, Inc. or its subsidiaries.

### TYPICAL APPLICATION

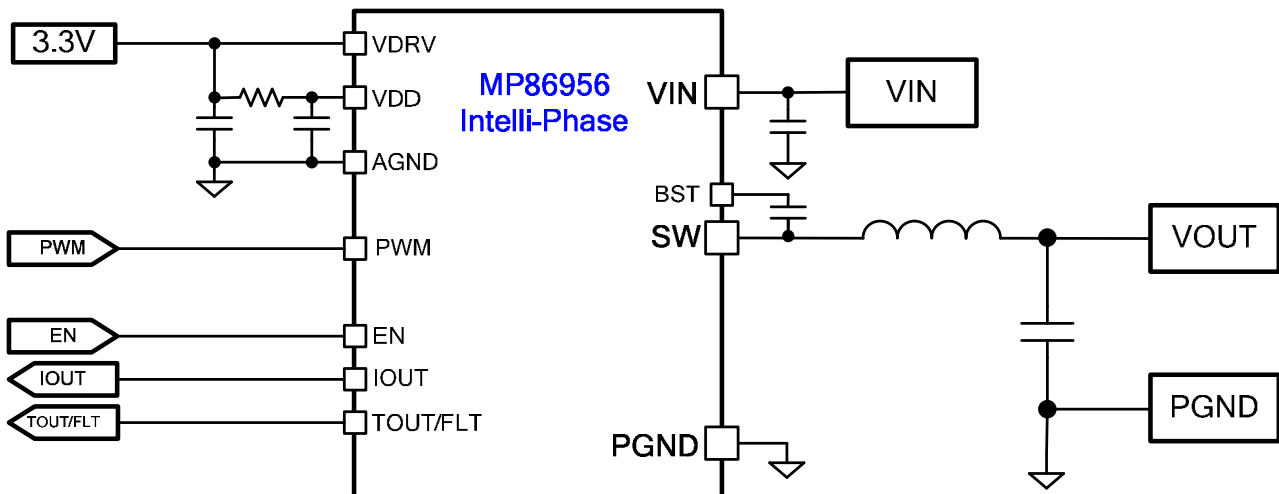

### ORDERING INFORMATION

Part Number*	Package	Top Marking
MP86956GMJ	LGA-41 (5mmx6mm)	See Below
MP86956GMJT	TLGA-41 (5mmx6mm)	

\* For Tape & Reel, add suffix -Z (e.g.: MP86956GMJ-Z, MP86956GMJT-Z).

#### TOP MARKING (MP86956GMJ)

MPSYYWW  
**MP86956**  
**LLLLLLL**

MPS: MPS prefix  
 YY: Year code  
 WW: Week code  
 MP86956: Part number  
 LLLLLLL: Lot number

#### TOP MARKING (MP86956GMJT)

MPSYYWW  
**MP86956**  
**LLLLLLL**  
**T**

MPS: MPS prefix  
 YY: Year code  
 WW: Week code  
 MP86956: Part number  
 LLLLLLL: Lot number  
 T: Thin

### PACKAGE REFERENCE

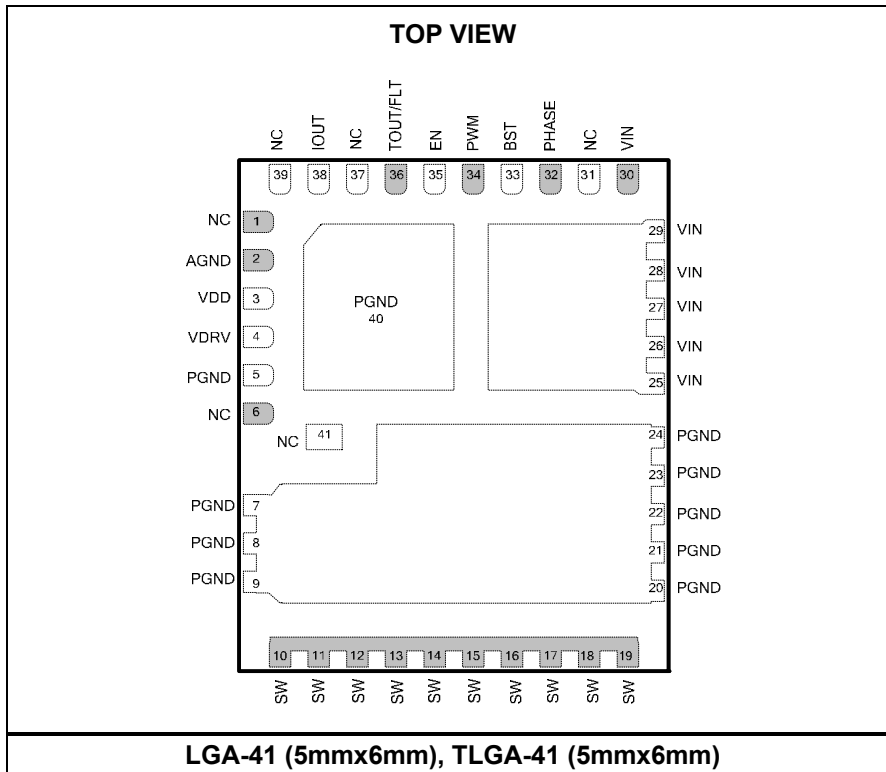

## PIN FUNCTIONS

Pin #	Pin Name	Descriptions
1, 6, 31, 37, 39, 41	NC	<b>No connection.</b>
2	AGND	<b>Analog ground.</b>
3	VDD	<b>Supply voltage for internal circuitry.</b> Connect VDD to VDRV through a 2.2Ω resistor. Decouple VDD with a 1μF capacitor to AGND. Connect AGND and PGND at the VDD capacitor.
4	VDRV	<b>Driver voltage.</b> Connect VDRV to a 3.3V supply. Decouple VDRV with a 1μF to a 4.7μF ceramic capacitor.
5, 7 - 9, 20 - 24, 40	PGND	<b>Power ground.</b>
10 - 19	SW	<b>Phase node.</b>
25 - 30	VIN	<b>Input supply voltage.</b> Place input ceramic capacitors (C <sub>IN</sub> ) close to the device to support the switching current with minimal parasitic inductance.
32	PHASE	<b>Switching node for the bootstrap capacitor connection.</b> PHASE pin is connected to SW internally.
33	BST	<b>Bootstrap.</b> BST requires a 0.1μF to 0.22μF capacitor to drive the power switch's gate above the supply voltage. Connect the capacitor between SW and BST to form a floating supply across the power switch driver.
34	PWM	<b>Pulse-width modulation input.</b> Leave PWM floating or drive PWM to a mid-state level to put SW in a high impedance state.
35	EN	<b>Enable.</b> Pull EN low to disable the MP86956 and place SW in a high impedance state.
36	TOUT/FLT	<b>Single-pin temperature sense and fault reporting.</b> TOUT/FLT is pulled up to the VDD voltage when a fault occurs.
38	IOUT	<b>Current sense output.</b> Use an external resistor to adjust the voltage proportional to the inductor current.

### ABSOLUTE MAXIMUM RATINGS <sup>(1)</sup>

Supply voltage (V <sub>IN</sub> )	18V
V <sub>IN</sub> to V <sub>PHASE (DC)</sub>	-0.3V to 25V
V <sub>IN</sub> to V <sub>PHASE (10ns)</sub>	-5V to 32V
V <sub>SW</sub> to PGND (DC)	-0.3V to V <sub>IN</sub> + 0.3V
V <sub>SW</sub> to PGND (25ns)	-5V to 25V
V <sub>BST</sub>	V <sub>PHASE</sub> + 4V
V <sub>DD</sub> , V <sub>DRV</sub>	-0.3V to +4V
All other pins	-0.3V to VDD + 0.3V
Instantaneous current	125A
Junction temperature	150°C
Lead temperature	260°C
Storage temperature	-65°C to +150°C

### Recommended Operating Conditions <sup>(2)</sup>

Supply voltage (V <sub>IN</sub> )	3.0V to 16V
Driver voltage (VDRV)	3.0V to 3.6V
Logic voltage (VDD)	3.0V to 3.6V
Operating junction temp. (T <sub>J</sub> )	-40°C to +125°C

### Thermal Resistance <sup>(3)</sup> θ<sub>JB</sub> θ<sub>JC\_TOP</sub>

LGA-41 (5mmx6mm)	2.2	8.7	°C/W
TLGA-41 (5mmx6mm)	2.2	2.0	°C/W

#### NOTES:

- Exceeding these ratings may damage the device.
- The device is not guaranteed to function outside of its operating conditions.
- θ<sub>JB</sub>: Thermal resistance from the junction to board around the PGND soldering point.  
θ<sub>JC\_TOP</sub>: Thermal resistance from the junction to the top of the package.

## ELECTRICAL CHARACTERISTICS

$V_{IN} = 12V$ ,  $V_{DRV} = V_{DD} = EN = 3.3V$ ,  $T_A = 25^\circ C$  for typical value,  $T_J = -40^\circ C$  to  $125^\circ C$  for max and min values, unless otherwise noted.

Parameter	Symbol	Condition	Min	Typ	Max	Units
$I_{IN}$ shutdown		EN = low		90	180	$\mu A$
$V_{IN}$ under-voltage lockout threshold rising				2.5	3.0	V
$V_{IN}$ under-voltage lockout threshold hysteresis				450		mV
$I_{VDRV}$ quiescent current		PWM = low		250	350	$\mu A$
$I_{VDD}$ quiescent current		PWM = low		3		mA
VDD voltage UVLO rising				2.75	2.95	V
VDD voltage UVLO hysteresis				300		mV
High-side current limit <sup>(4)</sup>	$I_{LIM\_FLT}$	Cycle-by-cycle up to 8 cycles		110		A
Low-side current limit <sup>(4)</sup>		Negative current limit, cycle-by-cycle, no fault report		-35		A
Negative current limit low-side off time <sup>(4)</sup>				200		ns
High-side current limit shutdown counter <sup>(4)</sup>				8		Times
Dead time at SW is rising <sup>(4)</sup>				2		ns
Dead time at SW is falling <sup>(4)</sup>		Positive inductor current		6		ns
		Negative inductor current		28		ns
EN input high threshold voltage			2.30			V
EN input low threshold voltage					0.8	V
PWM high to SW rising delay <sup>(4)</sup>	$t_{Rising}$			20		ns
PWM low to SW falling delay <sup>(4)</sup>	$t_{Falling}$			20		ns
PWM tri-state to SW Hi-Z delay <sup>(4)</sup>	$t_{LT}$			40		ns
	$t_{TL}$			30		ns
	$t_{HT}$			40		ns
	$t_{TH}$			30		ns
Minimum PWM pulse width <sup>(4)</sup>				30		ns
IOUT sense gain accuracy <sup>(4)</sup>		$20A \leq I_{SW} \leq 70A$	-2	0	+2	%
IOUT sense gain	$G_{IOUT}$			5		$\mu A/A$
IOUT sense offset		$I_{SW} = 0A$ , $V_{IOUT} = 1.2V$ , $T_J = 25^\circ C$	-2	0	2	$\mu A$
		SW = Hi-Z, $V_{IOUT} = 1.2V$	-1	0	1	$\mu A$
IOUT pin voltage range <sup>(4)</sup>	$V_{IOUT}$		0.7		2.1	V

**ELECTRICAL CHARACTERISTICS (continued)**

$V_{IN} = 12V$ ,  $V_{DRV} = V_{DD} = EN = 3.3V$ ,  $T_A = 25^{\circ}C$  for typical value and  $T_J = -40^{\circ}C$  to  $125^{\circ}C$  for max and min values, unless otherwise noted.

Parameter	Symbol	Condition	Min	Typ	Max	Units
TOUT/FLT sense gain <sup>(4)</sup>				8		mV/°C
TOUT/FLT sense offset <sup>(4)</sup>		$T_J = 25^{\circ}C$		800		mV
Over-temperature shutdown and fault flag <sup>(4)</sup>				160		°C
TOUT/FLT when fault <sup>(4)</sup>			3.0	3.3		V
PWM resistor		Pull up, EN = high		6		kΩ
		Pull down, EN = high		5		kΩ
PWM logic high voltage			2.30			V
PWM tri-state region			1.10		1.8	V
PWM logic low voltage					0.80	V

**NOTE:**

4) Guaranteed by design or characterization data, not tested in production.

**PWM TIMING DIAGRAM**

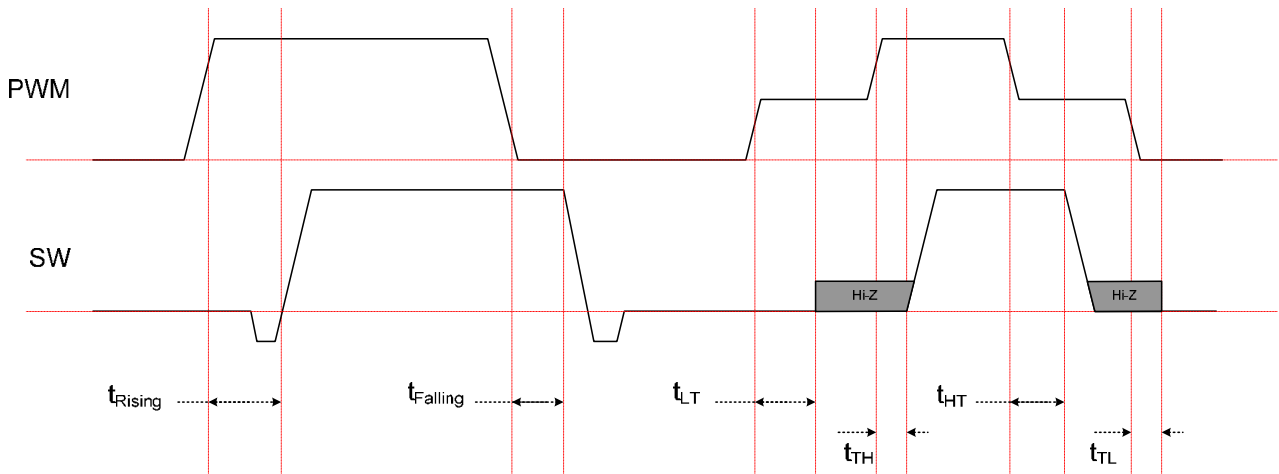

### TYPICAL CHARACTERISTICS

**Efficiency and Loss**

$V_{IN} = 12V$ ,  $L = 150nH$ ,  $F_{SW} = 500kHz$

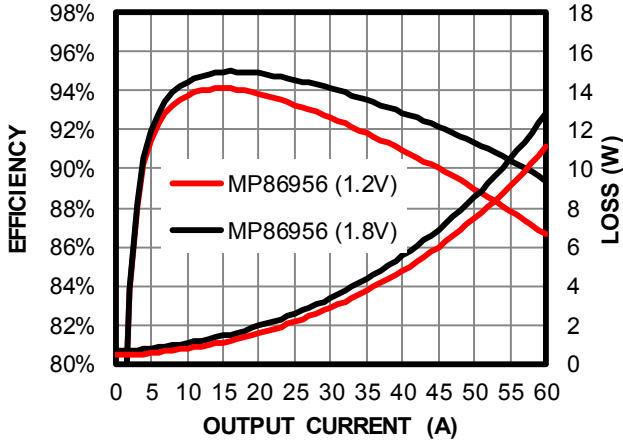

**VDD UVLO**

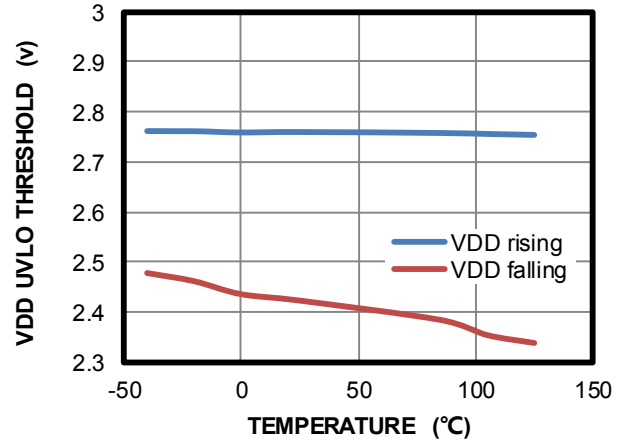

**EN\_HI**

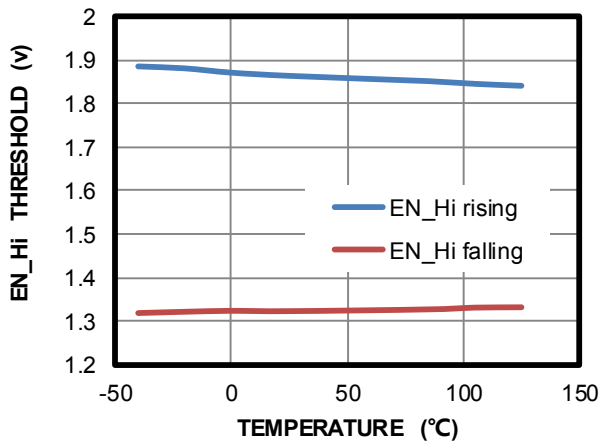

**PWM\_LO**

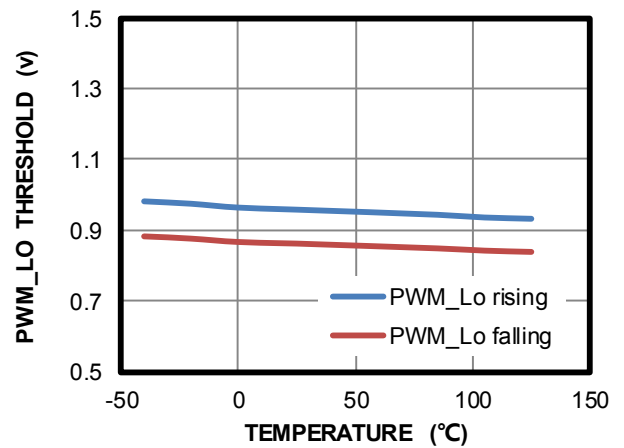

**PWM\_HI**

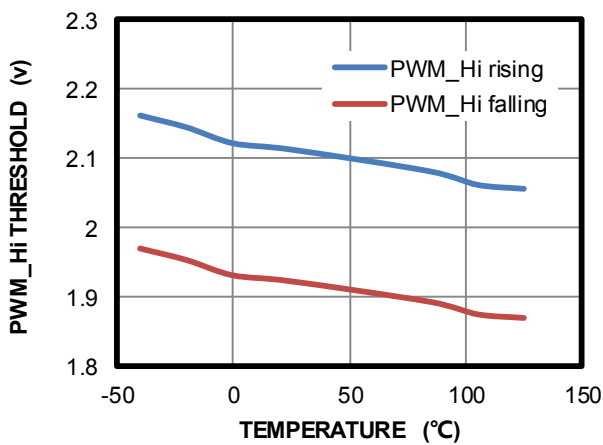

## TYPICAL PERFORMANCE CHARACTERISTICS

### Switching

$V_{IN} = 12V$ ,  $L = 150nH$ , Load = 30A

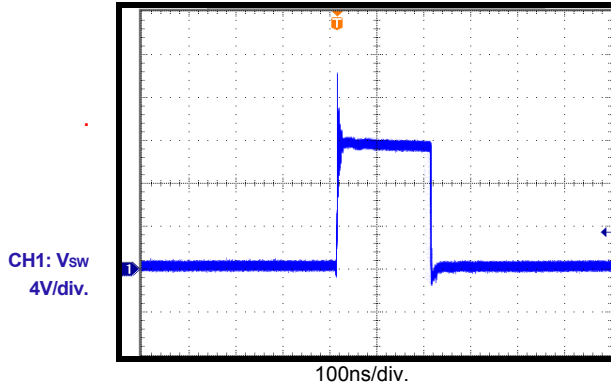

### Dead Time @ SW Ringing

Load = 30A

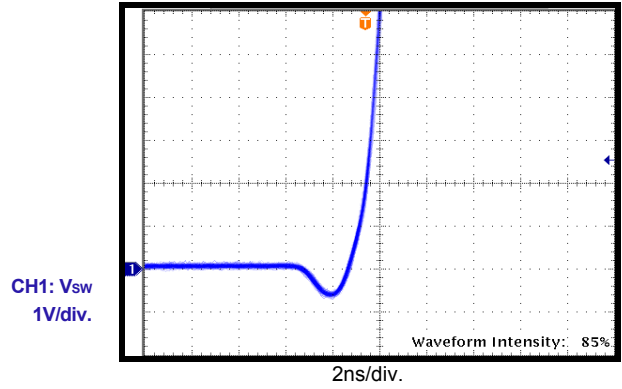

### IOUT Output

Load = 0A

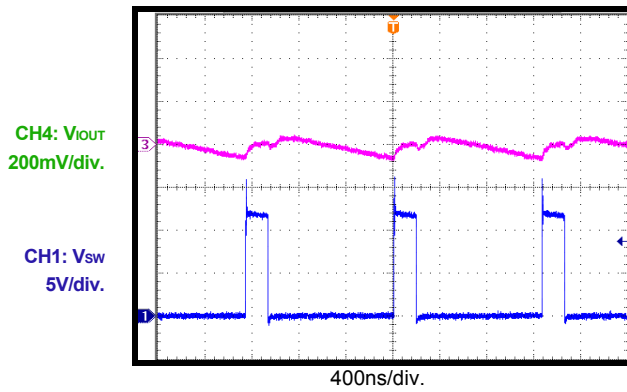

### IOUT Output

Load = 30A

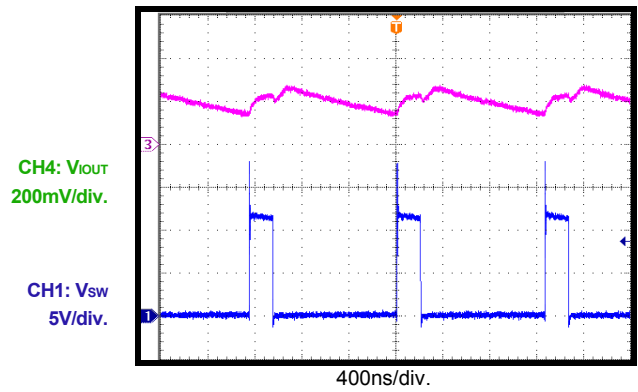

### HS Current Limit

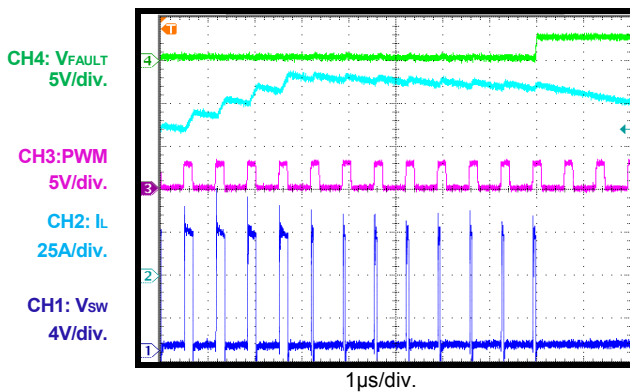

**BLOCK DIAGRAM**

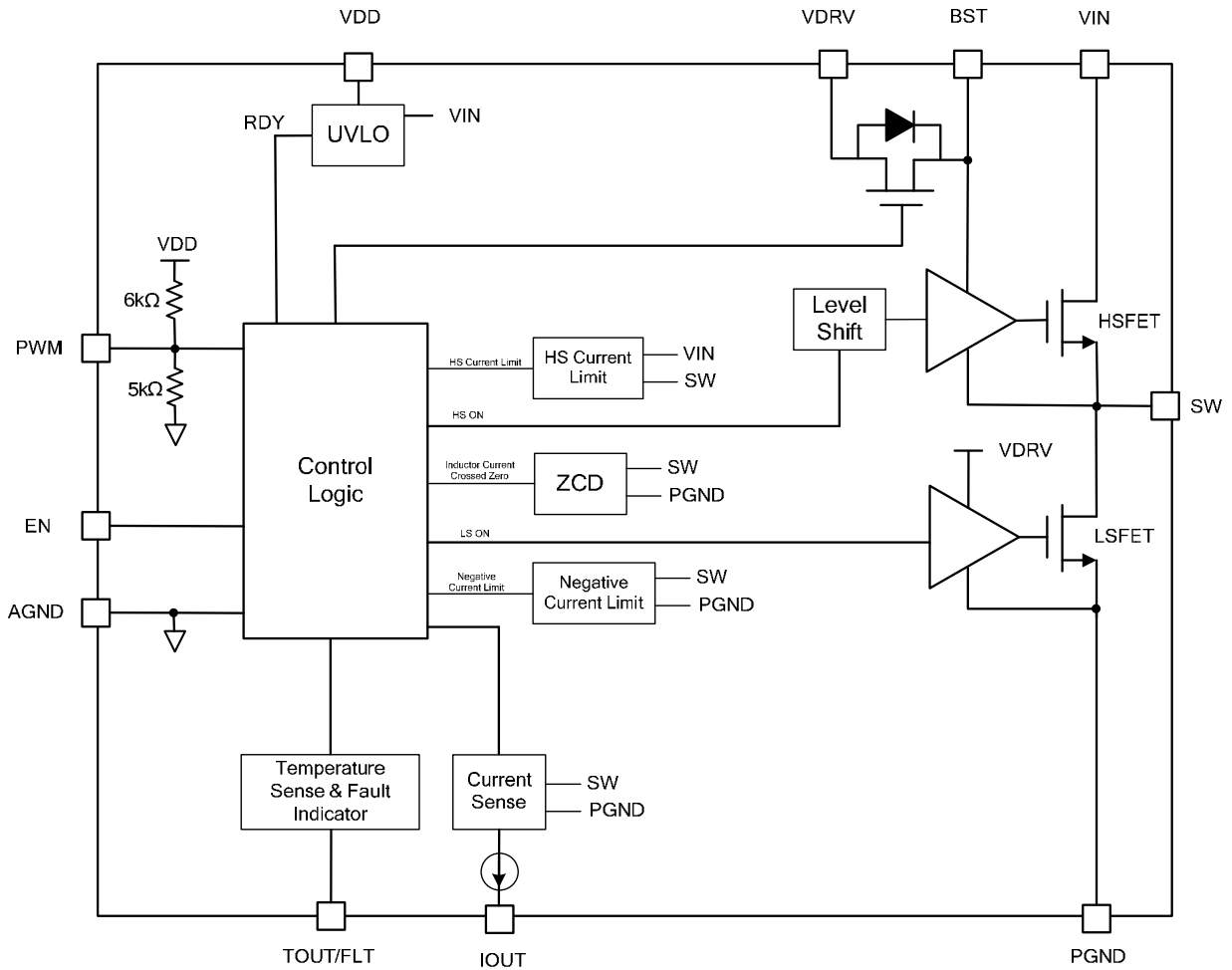

**Figure 1: Functional Block Diagram**



## APPLICATION INFORMATION

### Operation

The MP86956 is a 70A, monolithic, half-bridge driver with MOSFETs ideally suited for multi-phase buck regulators. An external 3.3V supply is required to supply both VDD and VDRV. When EN transitions from low to high and the VDRV signals are sufficiently high, operation begins.

### Pulse-Width Modulation (PWM)

The pulse-width modulation (PWM) input pin is capable of tri-state input. When the PWM input signal is within the tri-state threshold window for a typical 50ns ( $T_{HT}$  or  $T_{LT}$ ), the high-side MOSFET (HS-FET) turns off immediately, and the low-side MOSFET (LS-FET) enters diode emulation mode, which is on until zero-current detection (ZCD). The tri-state PWM input can come from a forced mid-voltage PWM signal or made by floating the PWM input. The internal current source charges the signal to a middle voltage. Refer to the PWM timing diagram on page 5 for the propagation delay definition from PWM to SW node.

### Diode Emulation Mode

In diode emulation mode, when PWM is low or in a tri-state input, the LS-FET is turned on whenever the inductor current is positive. The LS-FET turns off if the inductor current is negative or after the inductor current crosses the zero current. Diode emulation mode can be enabled by driving PWM to a middle state or by floating PWM.

### Current Sense

IOUT is a bidirectional current source pin proportional to the inductor current. The current sensing gain is 5 $\mu$ A/A. A resistor is used to program the voltage gain proportional to the inductor current, if needed.

The IOUT output has two states (see Table 1). In disable mode (EN = low), the current sense circuit is disabled, and IOUT is in Hi-Z (high impedance) state.

**Table 1: IOUT Output States**

PWM	EN	IOUT
PWM	High	Active
x	Low	Hi-Z

An IOUT voltage range of 0.7 - 2.1V is required to achieve an accurate IOUT current output of up to +350 $\mu$ A/-200 $\mu$ A (i.e.: +70A/-40A). Generally, there is a resistor ( $R_{IOUT}$ ) connected from IOUT to an external voltage that is capable of sinking small currents to provide enough voltage level to meet the required operating voltage range. A proper reference voltage,  $V_{CM}$ , and  $R_{IOUT}$  values can be determined with Equation (1) and Equation (2):

$$0.7V < I_{IOUT} \times R_{IOUT} + V_{CM} < 2.1V \quad (1)$$

$$I_{IOUT} = I_{SW} \times G_{IOUT} \quad (2)$$

Where  $V_{CM}$  is a reference voltage connected to  $R_{IOUT}$ .

Intelli-Phase's current sense output can be used by the controller to monitor the output current accurately. The cycle-by-cycle current information from IOUT can be used for phase-current balancing, over-current protection, and active-voltage positioning (output voltage droop).

### Positive and Negative Inductor Current Limit

When HS-FET over-current is detected, the HS-FET turns off for that PWM cycle. If there are eight consecutive cycles of an HS-FET current limit event, the HS-FET latches off, TOUT/FLT pulls high to VDD, and the LS-FET turns on until ZCD. Toggle EN or recycle  $V_{IN}$  or  $V_{DD}$  to release the latch and restart the device.

When the LS-FET detects a -35A valley current, the MP86956 turns off the LS-FET and turns on the HS-FET for 200ns to limit the negative current. The LS-FET negative current limit will not trigger a fault report.

### Temperature Sense Output with Fault indicator (TOUT/FLT)

TOUT/FLT is a pin with two functions: junction temperature sense and fault detection.

TOUT/FLT is a voltage output proportional to the junction temperature whenever VDD is higher than its UVLO and the part is in active mode. The gain is 8mV/ $^{\circ}$ C and has a +800mV offset at 25 $^{\circ}$ C. For example, 0.8V @  $T_J = 25^{\circ}$ C and 1.6V @  $T_J = 125^{\circ}$ C.

When any fault occurs, TOUT/FLT is pulled to the VDD voltage to report the fault event regardless of the temperature. 200ns after the fault has occurred, the PWM impedance changes accordingly to indicate the fault type. Table 2 shows the PWM status regarding each fault event.

**Table 2: PWM Resistance when a Fault Occurs**

Fault Type	PWM
HS-FET current limit protection	10kΩ to AGND
Over-temperature protection	20kΩ to AGND
SW-PGND short protection	1kΩ to VDD

TOUT/FLT can monitor three fault events.

1. Over-current limit (HS-FET): To trip the over-current fault, the current limit must be exceeded eight consecutive times. Once a fault occurs, the MP86956 latches off to

turn off the HS-FET. The LS-FET turns OFF when the inductor current reaches zero. PWM uses a 10kΩ resistor to AGND to indicate the fault type.

2. Over-temperature fault at  $T_j > 160^\circ\text{C}$ : Once a fault occurs, the MP86956 latches off to turn off the HS-FET. The LS-FET turns off when the inductor current reaches zero. PWM uses a 20kΩ resistor to AGND to indicate the fault type.
3. SW to PGND shorted: Once a fault occurs, the MP86956 latches off to turn off the HS-FET. PWM is pulled high (1kΩ to VDD) to indicate the fault type.

The fault latch can be released by toggling EN or by recycling VIN or VDD.

For multi-phase operation, connect TOUT/FLT of each Intelli-Phase together (see Figure 3).

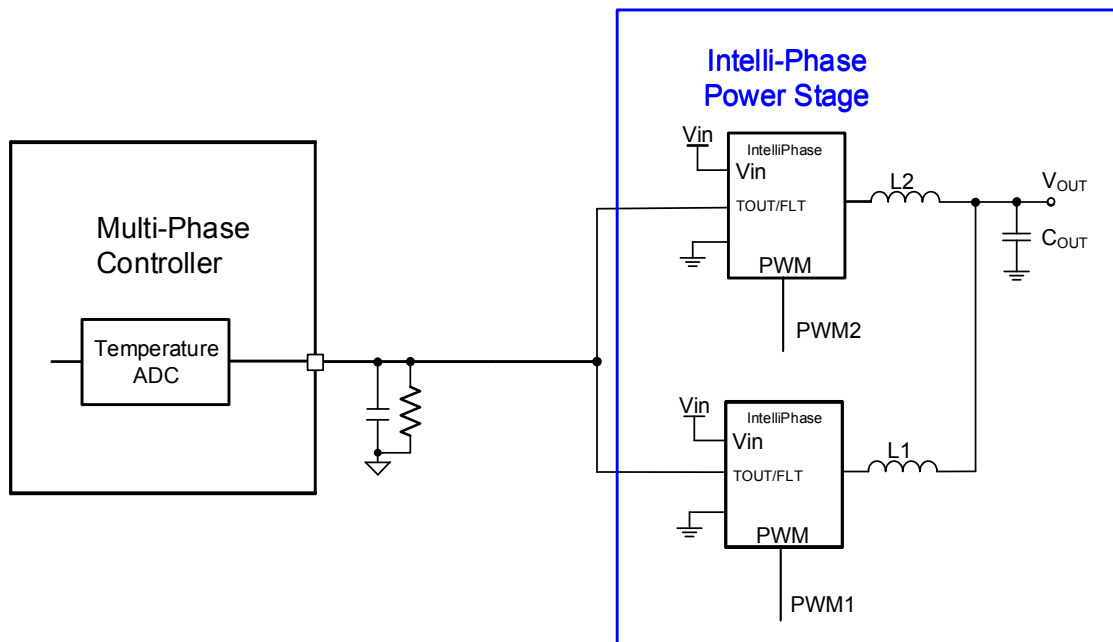
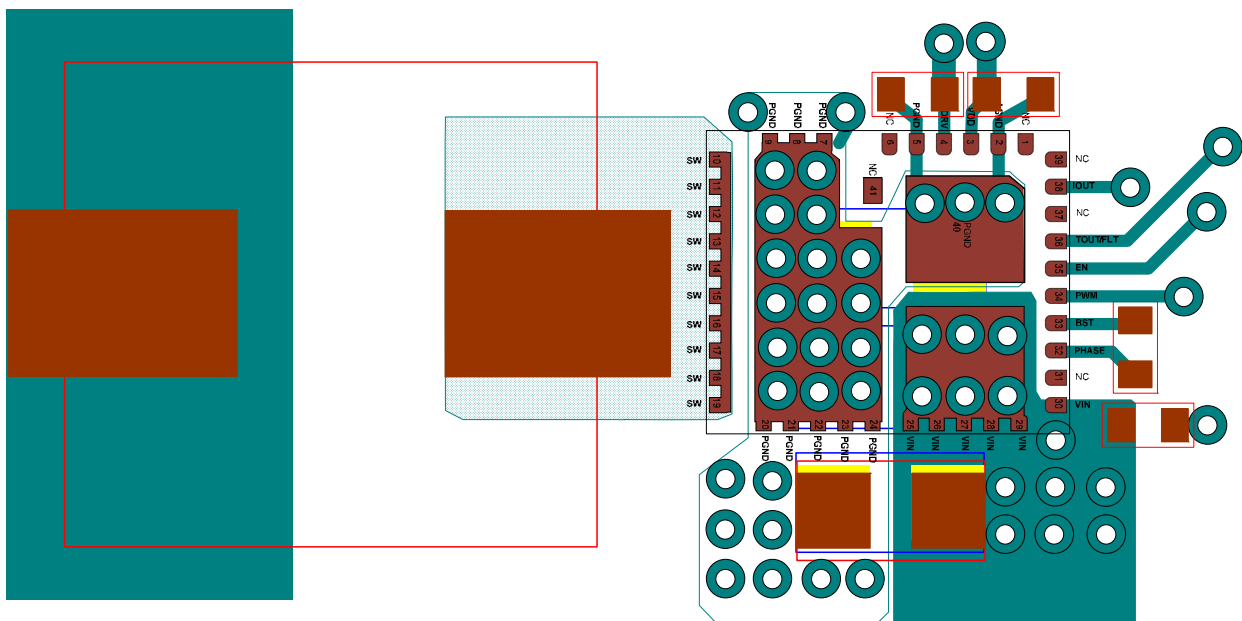

**Figure 3: Multi-Phase Temperature Sense Utilization**

### PCB Layout Guidelines

Efficient PCB layout is critical for stable operation. For best results, refer to Figure 4 and follow the guidelines below.

1. Place the input MLCC capacitors as close to VIN and PGND as possible.
2. Place the major MLCC capacitors on the same layer as the MP86956.
3. Place as many VIN and PGND vias underneath the package as possible.
4. Place the vias between the VIN or PGND long pads.
5. Place a VIN copper plane on the second inner layer to form the PCB stack as positive/negative/positive to reduce the parasitic impedance from the input MLCC capacitor to the MP86956.
6. Ensure that the copper plane on the inner layer at least covers the VIN vias underneath the package and input MLCC capacitors.
7. Place more PGND vias close to the PGND pin/pad to minimize both parasitic resistance/impedance and thermal resistance.
8. Place BST capacitor and VDRV capacitor as close to the MP86956's pins as possible.
9. Use a trace width of 20 mils or higher to route the path.
10. Avoid placing vias on the BST driving path.
11. Use a 0.1 - 0.22 $\mu$ F bootstrap capacitor.
12. Place the VDD decoupling capacitor close to the device.
13. Connect AGND and PGND at the point of the VDD capacitor's ground connection.
14. Keep the IOUT signal trace away from high-current path like SW and PWM.



**Figure 4: Example of PCB Layout (Placement and Top Layer PCB)**

Input Capacitor: 0805 package (top and bottom sides) and 0402 package (top side)

Inductor: 11x8 package

VDD/BST/VDRV capacitor: 0402 package

Via size: 20/10 mils

# PACKAGE INFORMATION

## LGA-41 (5mmx6mm)

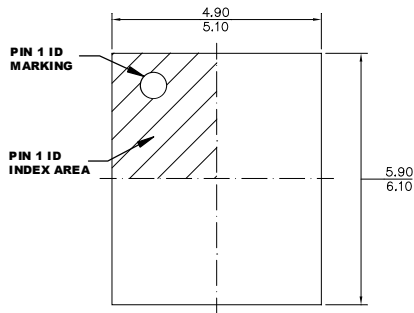

**TOP VIEW**

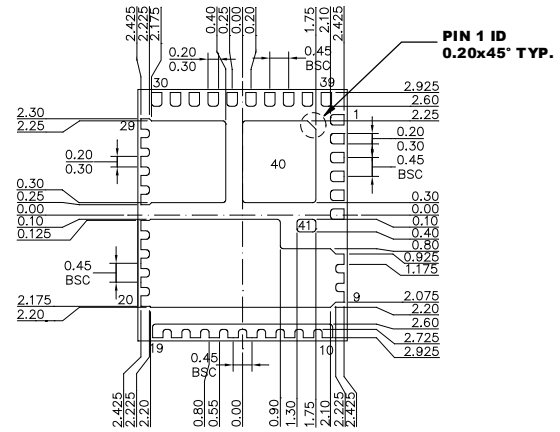

**BOTTOM VIEW**



**SIDE VIEW**

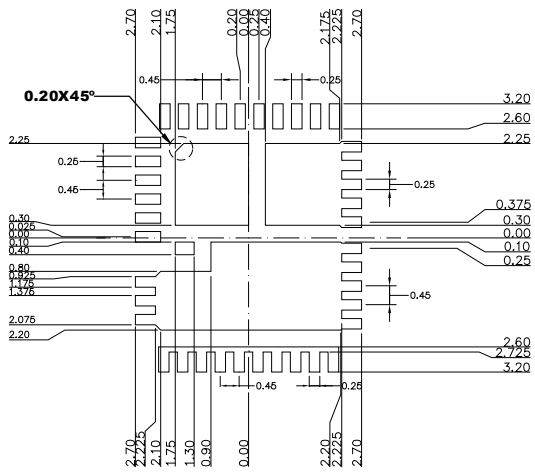

**RECOMMENDED LAND PATTERN**

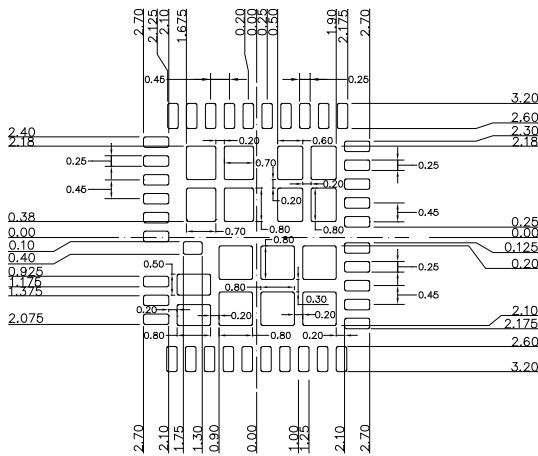

**RECOMMENDED STENCIL DESIGN**

**NOTE:**

- 1) ALL DIMENSIONS ARE IN MILLIMETERS.
- 2) LEAD COPLANARITY SHALL BE 0.10 MILLIMETERS MAX.
- 3) JEDEC REFERENCE IS MO-303.
- 4) DRAWING IS NOT TO SCALE.

PACKAGE INFORMATION (continued)

TLGA-41 (5mmx6mm)

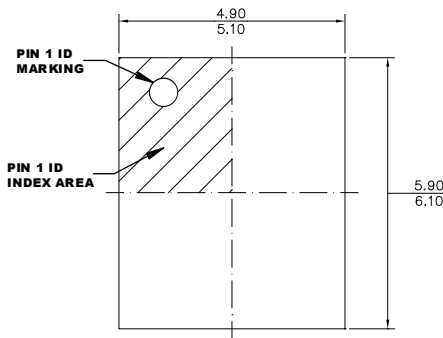

TOP VIEW

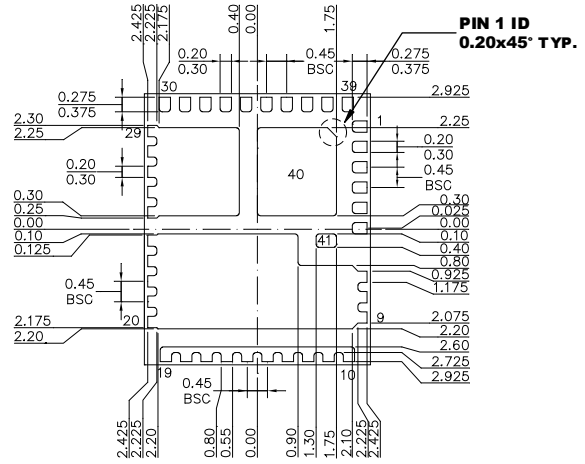

BOTTOM VIEW



SIDE VIEW

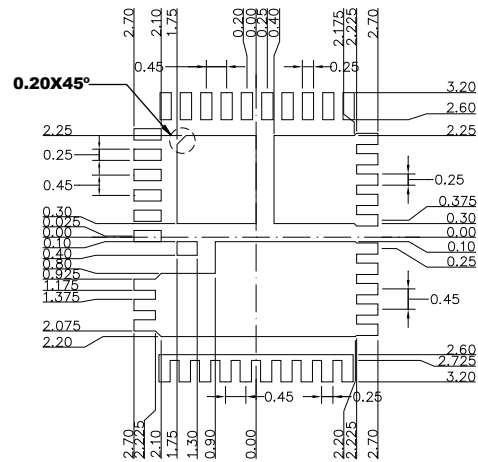

RECOMMENDED LAND PATTERN

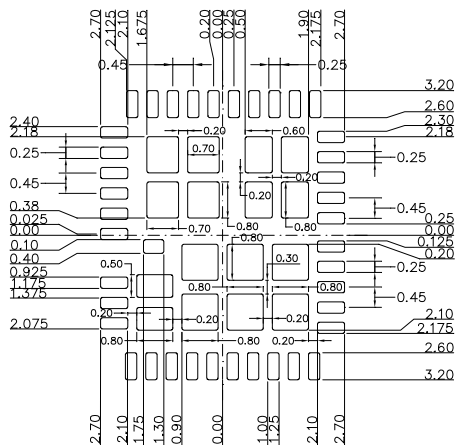

RECOMMENDED STENCIL DESIGN

NOTE:

- 1) ALL DIMENSIONS ARE IN MILLIMETERS.
- 2) LEAD COPLANARITY SHALL BE 0.10 MILLIMETERS MAX.
- 3) JEDEC REFERENCE IS MO-303.
- 4) DRAWING IS NOT TO SCALE.

## Revision History

Revision #	Revision Date	Description	Pages Updated
1.1	4/27/2020	Remove all TLGA information	Page1-13
1.2	07/10/2020	Update the descriptions for pin 32	P3
		Add ( $V_{IN}$ to $V_{PHASE}$ ) to Absolute Maximum Ratings	P3
		Update the typical NOCP LS off time to 200ns	P4
		Update the typical minimum PWM pulse width to 30ns	P4
		Revise Typical Characteristics for threshold of EN	P6
		Revise the figure of temperature sense utilization for multi-phase operation	P10
		Correct the BST capacitor's capacitance to 0.22uF	P11
		Update the recommended Land Pattern and Stencil Design	P12
1.3	07/20/2020	Add TLGA information	Page1-13

**NOTICE:** The information in this document is subject to change without notice. Please contact MPS for current specifications. Users should warrant and guarantee that third party Intellectual Property rights are not infringed upon when integrating MPS products into any application. MPS will not assume any legal responsibility for any said applications.