



# **EVQ8633B-LE-00A**

## **High Efficiency, 16V, 20A Synchronous Step-Down Converter Evaluation Board**

### **DESCRIPTION**

The EVQ8633B-LE-00A is an evaluation board for the MPQ8633B, a high-efficiency, monolithic, synchronous, step-down converter.

This EVB can deliver 20A of continuous load current over a wide operating input range. High efficiency can be achieved over a wide output current load range.

The MPQ8633B adopts internally compensated constant-on-time (COT) control mode that provides fast transient response and eases loop stabilization.

This EVB can be turned on or off via a remote on/off input (EN) referenced to ground. This input is compatible with popular logic devices.

### **ELECTRICAL SPECIFICATION**

Parameter	Symbol	Value	Units
Input voltage	V <sub>IN</sub>	8 - 16	V
Output voltage	V <sub>OUT</sub>	1	V
Output current	I <sub>OUT</sub>	20	A

### **FEATURES**

- Wide Input Voltage Range from 2.7V:
  - 2.7V to 16V with External 3.3V VCC Bias
  - 4V to 16V with Internal VCC Bias or External 3.3V VCC Bias
- Differential Output Voltage Remote Sense
- Programmable Accurate Current Limit Level
- 20A Output Current
- Low R<sub>DS(ON)</sub> Integrated Power MOSFETs
- Proprietary Switching Loss Reduction Technique

- Adaptive Constant-on-Time (COT) Control for Ultrafast Transient Response
- Stable with Zero-ESR Output Capacitor
- 0.5% Reference Voltage Over 0°C to +70°C Junction Temperature Range
- 1% Reference Voltage Over -40°C to +125°C Junction Temperature Range
- Selectable Pulse-Skip Mode or Forced CCM Operation
- Excellent Load Regulation
- Output Voltage Tracking
- Output Voltage Discharge
- PGOOD Active Clamped Low Level during Power Failure
- Programmable Soft Start Time from 1ms
- Pre-Bias Start-Up
- Selectable Switching Frequency of 600kHz, 800kHz, or 1000kHz
- Non-Latch OCP, UVP, UVLO, Thermal Shutdown, and Latch-Off for OVP
- Output Adjustable from 0.6V to 90%\*V<sub>in</sub>, Up to 5.5V Max
- Available in a QFN (3mmx4mm) Package

### **APPLICATIONS**

- Telecom and Networking Systems
- Servers, Cloud-Computing, Storage
- Base Stations
- General Purpose Point-of-Load (PoL)
- 12V Distribution Power Systems
- High-End TVs
- Game Consoles and Graphic Cards

All MPS parts are lead-free, halogen-free, and adhere to the RoHS directive. For MPS green status, please visit the MPS website under Quality Assurance. "MPS", the MPS logo, and "Simple, Easy Solutions" are trademarks of Monolithic Power Systems, Inc. or its subsidiaries.

EVQ8633B-LE-00A EVALUATION BOARD

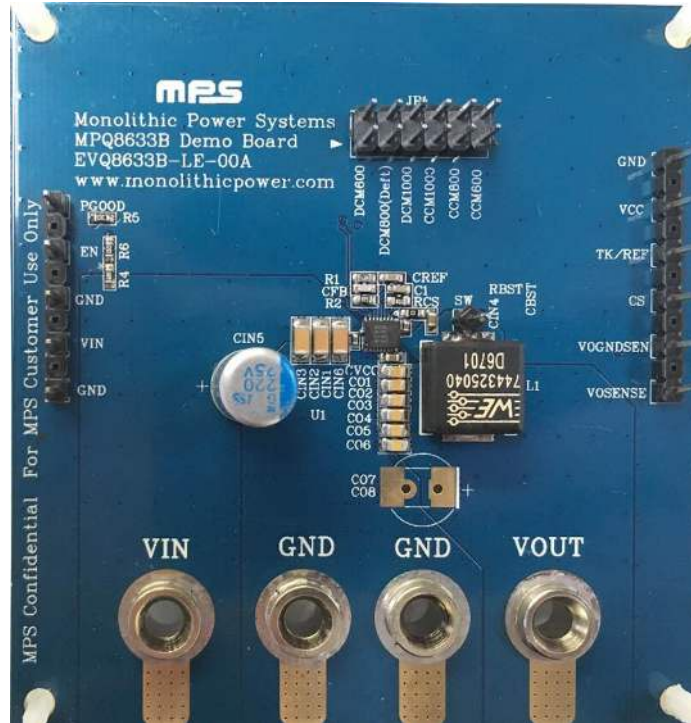

(L x W x H) 81.3mm x 77.5mm x 1.6 mm

Board Number	MPS IC Number
EVQ8633B-LE-00A	MPQ8633BGLE

### EVALUATION BOARD SCHEMATIC

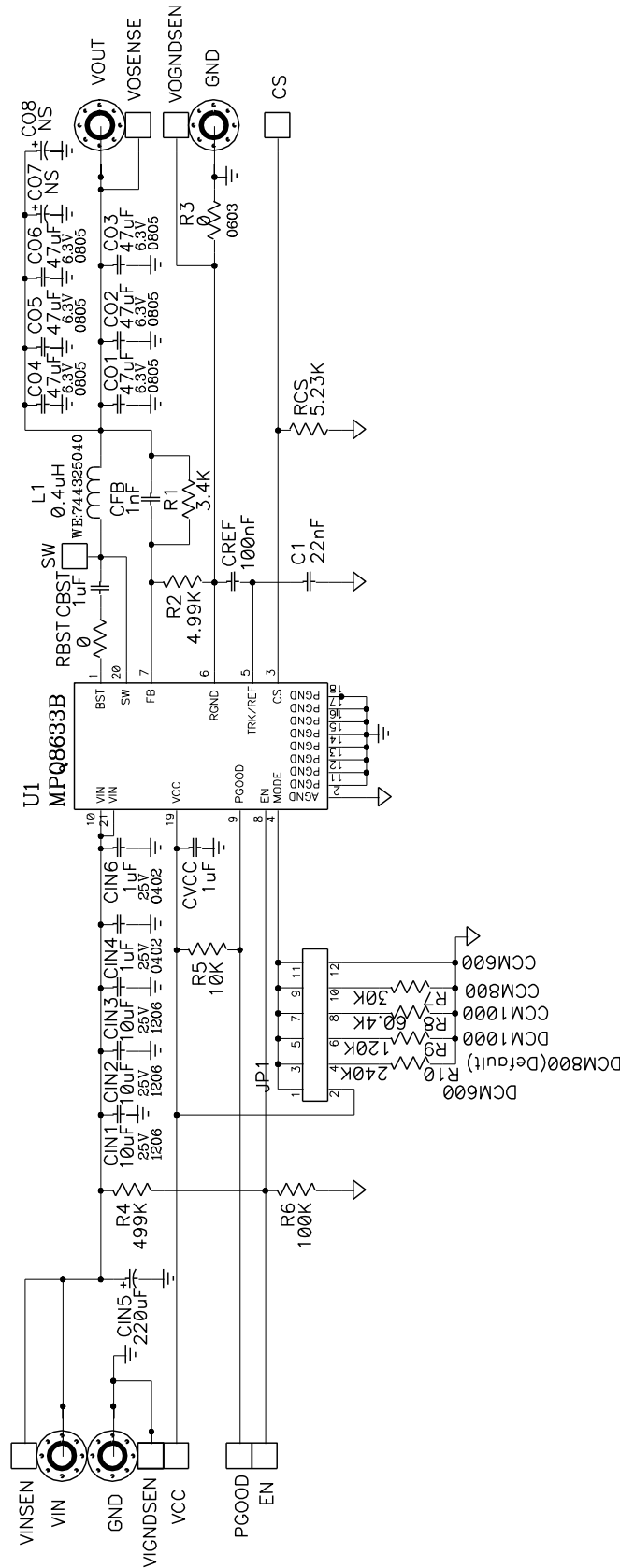

**EVQ8633B-LE-00A BILL OF MATERIALS**

Qty	Ref	Value	Description	Package	Manufacturer	Part Number
1	C1	22nF	CAP, 25V, 10%, X7R	CAP0603	Generic	
2	CBST, CVCC	1 $\mu$ F	CAP CER 1 $\mu$ F 6.3V 10% X7R 0603	CAP0603	Generic	
1	CFB	1nF	CAP, 50V, 10%, X7R	CAP0603	Generic	
3	CIN1, CIN2, CIN3	10 $\mu$ F	Capacitor, 25V, X7R, 10%	CAP1206	Murata or Generic	GRM31CR71E106KA12L
2	CIN4, CIN6	1 $\mu$ F/25V	CAP CER 1 $\mu$ F 25V 10% X6S 0402	CAP0402	Murata or Generic	GRM155C81E105KE11D
1	CIN5	220 $\mu$ F	220 $\mu$ F, 25V, 16mOhm ESR	D8P3.5mm	Chemi-Con or Generic	APSG250ELL221MHB5S
6	CO1, CO2, CO3, CO4, CO5, CO6	47 $\mu$ F	CAP, 6.3V, X5R, 20%	CAP0805	Murata or Generic	GRM21BR60J476ME15L
1	CO7	NS		D2		
1	CO8	NS		D8P3.5mm		
1	CREF	100nF	CAP CER 0.1 $\mu$ F 25V 10% X7R 0603	CAP0603	Generic	
1	L1	0.4 $\mu$ H	Inductor	10x10mm	Würth or Generic	WE-744325040
1	R1	3.4k	Film Res., 1%	0603	Generic	
1	R2	4.99k	Film Res., 1%	0603	Generic	
2	R3, RBST	0	Film Res., 5%	0603	Generic	
1	R4	499k	Film Res., 1%	0603	Generic	
1	R5	10k	Film Res., 1%	0603	Generic	
1	R6	100k	Film Res., 1%	0603	Generic	
1	R7	30k	Film Res., 1%	0603	Generic	
1	R8	60.4k	Film Res., 1%	0603	Generic	
1	R9	120k	Film Res., 1%	0603	Generic	
1	R10	240k	Film Res., 1%		Generic	
1	RCS	5.23k	Film Res., 1%	0603	Generic	
1	U1	MQ8633 BGLE	16V/20A Step Down Convert	QFN21- 3x4mm	MPS	MQ8633BGLE

### EVB TEST RESULTS

Performance waveforms are tested on the EVQ8633B-LE-00A evaluation board.

$V_{IN} = 12V$ ,  $V_{OUT} = 1V$ ,  $L = 400nH$ ,  $T_A = +25^{\circ}C$ , unless otherwise noted.

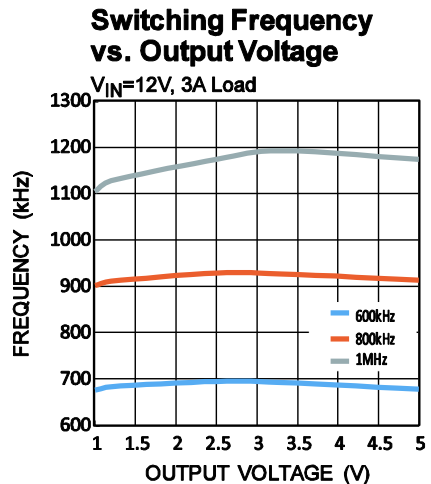
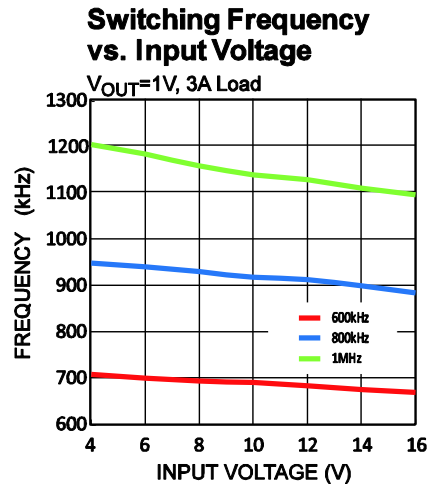
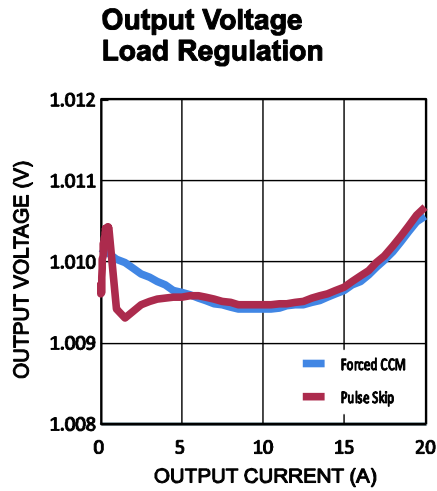
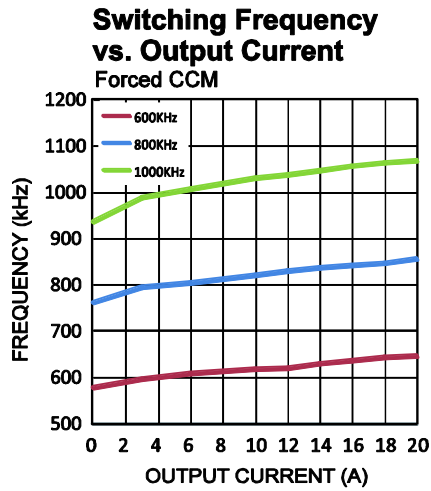
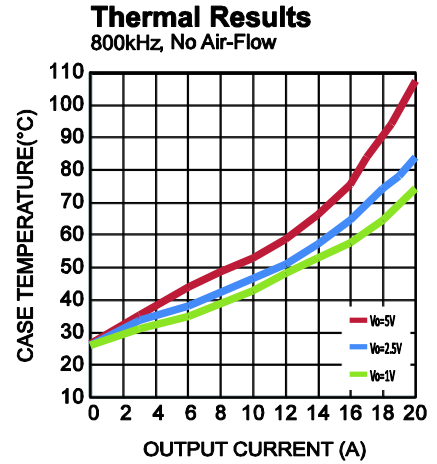
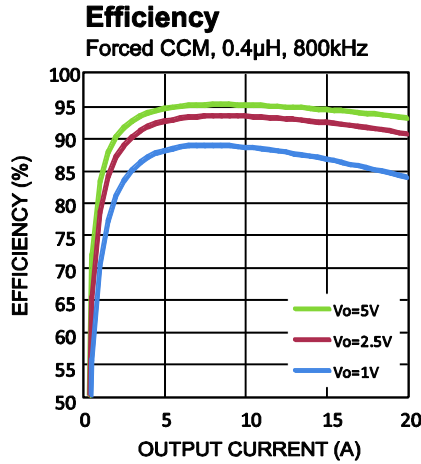
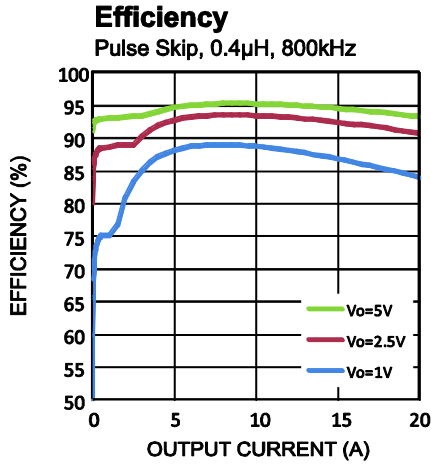

**EVB TEST RESULTS (continued)**

Performance waveforms are tested on the EVQ8633B-LE-00A evaluation board.

 $V_{IN} = 12V$ ,  $V_{OUT} = 1V$ ,  $L = 400nH$ ,  $T_A = +25^{\circ}C$ , unless otherwise noted.

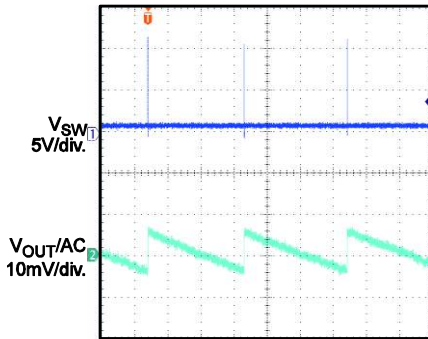
**Steady State**
 $I_{OUT} = 0A$ , Pulse Skip

200µs/div.

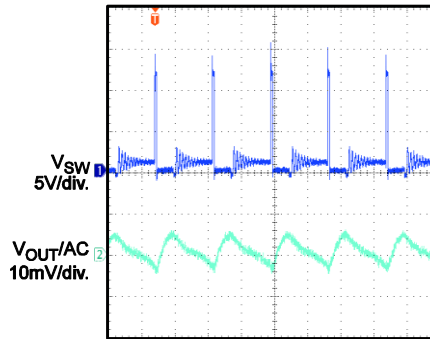
**Steady State**
 $I_{OUT} = 0.5A$ , Pulse Skip

2µs/div.

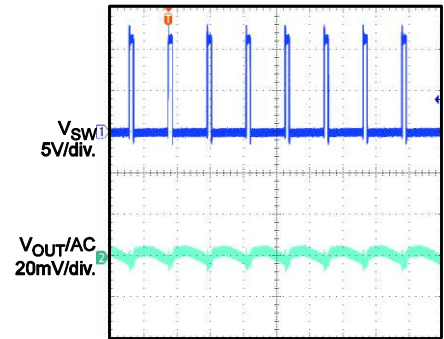
**Steady State**
 $I_{OUT} = 20A$ , Pulse Skip

1µs/div.

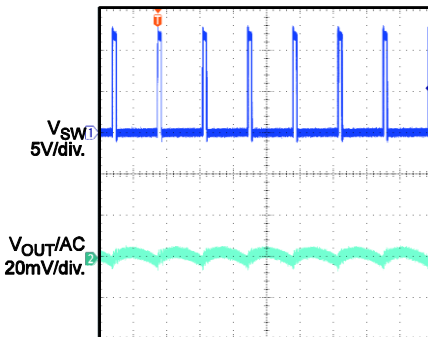
**Steady State**
 $I_{OUT} = 0A$ , Forced CCM

1µs/div

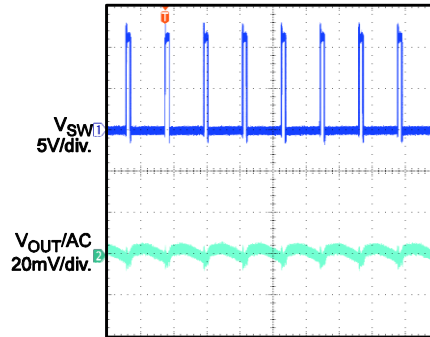
**Steady State**
 $I_{OUT} = 20A$ , Forced CCM

1µs/div

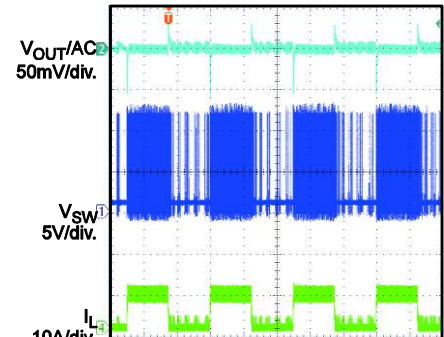
**Load Transient**
 $I_{OUT} = 0A \sim 8A$ , Pulse Skip

400µs/div

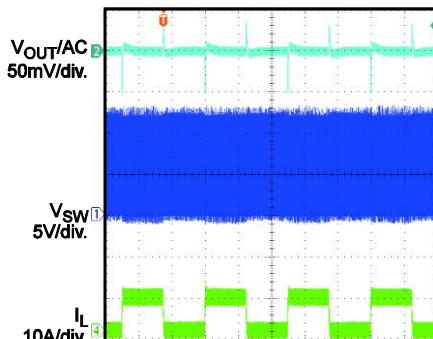
**Load Transient**
 $I_{OUT} = 0A \sim 8A$ , Forced CCM

400µs/div

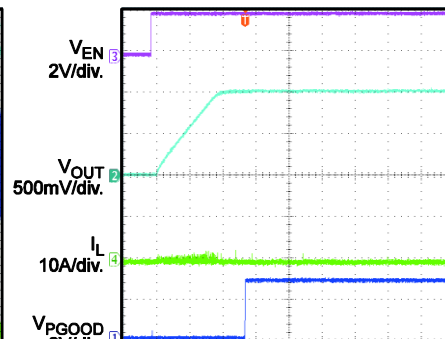
**Power Up through EN**
 $I_{OUT} = 0A$ , Pulse Skip

1ms/div

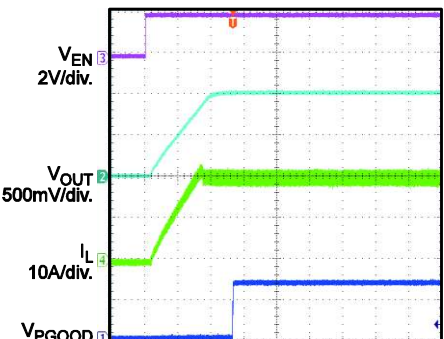
**Power Up through EN**
 $I_{OUT} = 20A$ , Pulse Skip

1ms/div

## EVB TEST RESULTS (continued)

Performance waveforms are tested on the EVQ8633B-LE-00A evaluation board.

$V_{IN} = 12V$ ,  $V_{OUT} = 1V$ ,  $L = 400nH$ ,  $T_A = +25^{\circ}C$ , unless otherwise noted.

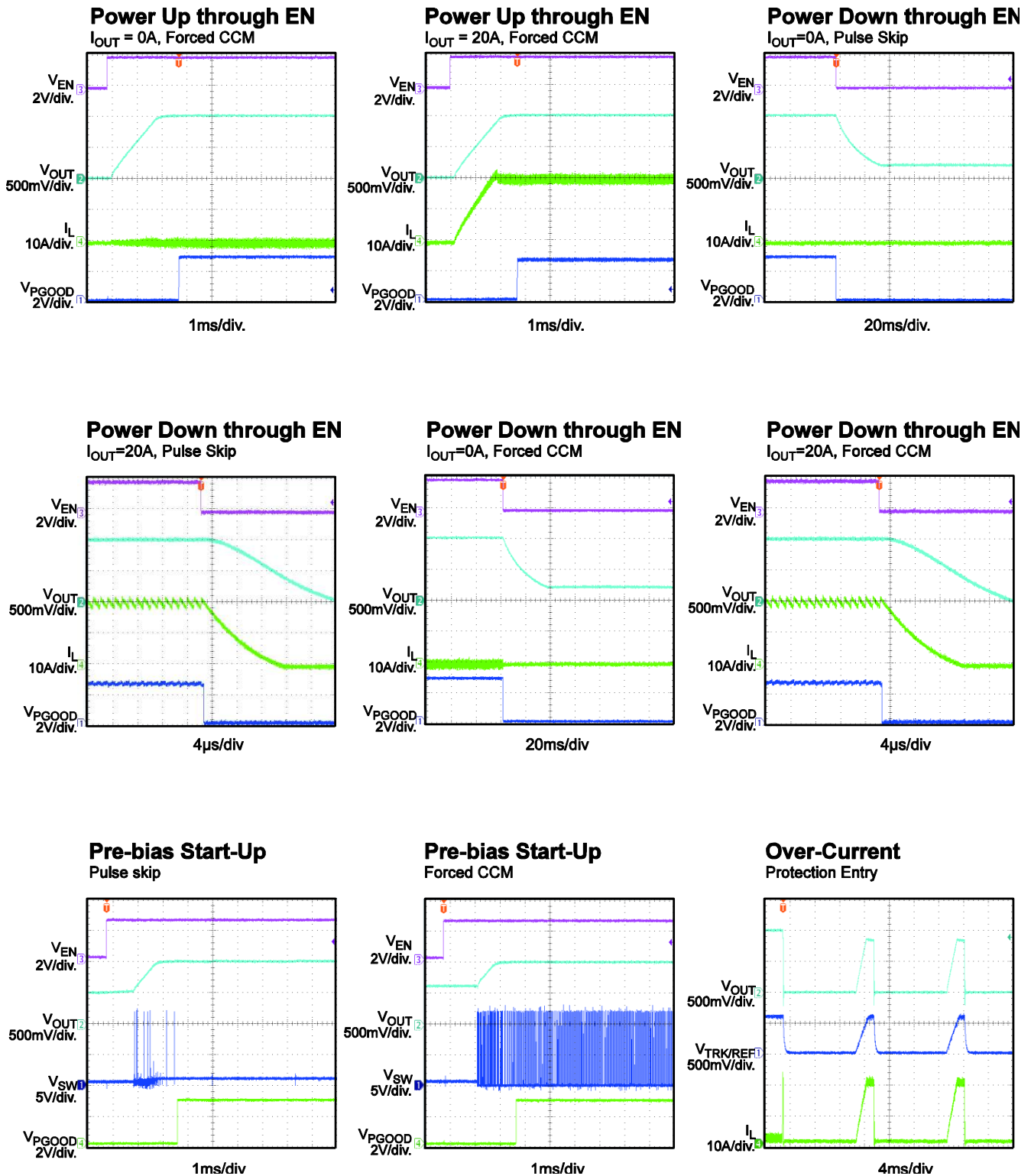

### EVB TEST RESULTS (continued)

Performance waveforms are tested on the EVQ8633B-LE-00A evaluation board.

$V_{IN} = 12V$ ,  $V_{OUT} = 1V$ ,  $L = 400nH$ ,  $T_A = +25^{\circ}C$ , unless otherwise noted.

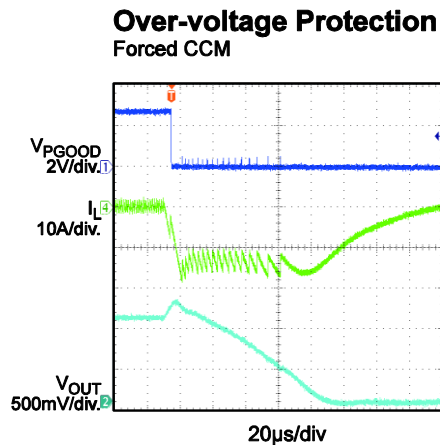
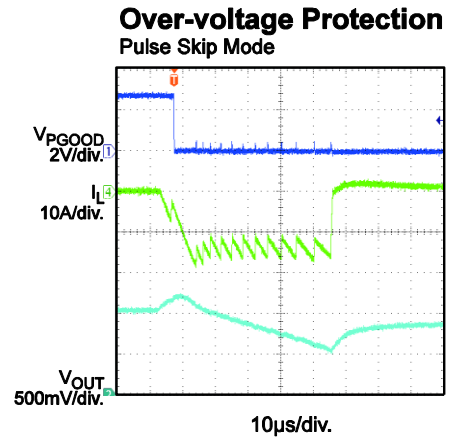
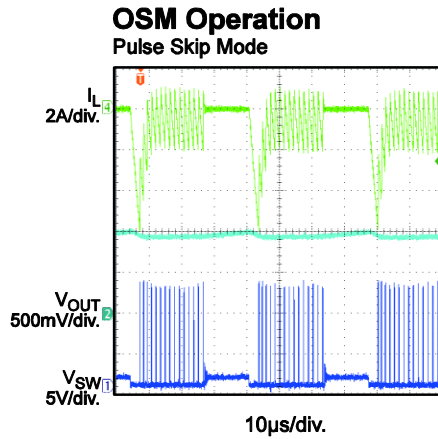
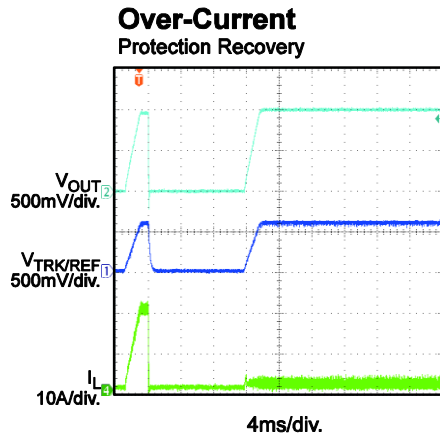



## PRINTED CIRCUIT BOARD LAYOUT

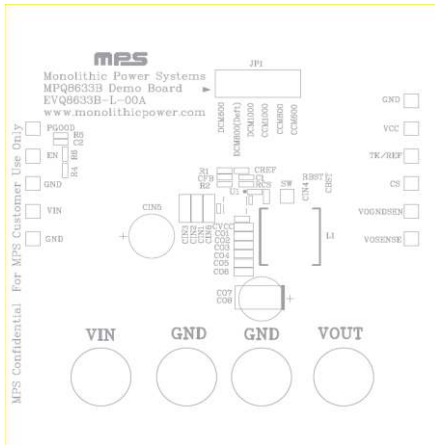

Figure 1: Top Silk Layer

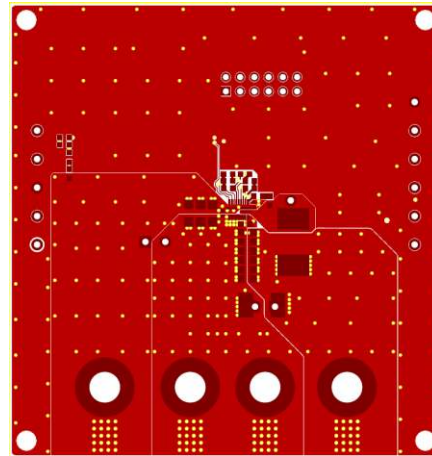

Figure 2: Top Layer

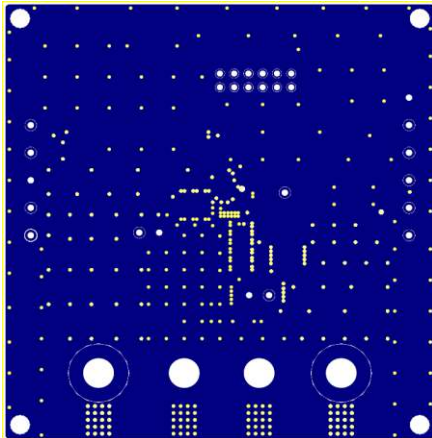

Figure 3: Inner Layer 1

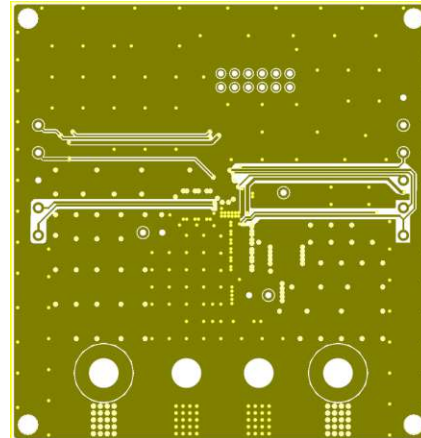

Figure 4: Inner Layer 2

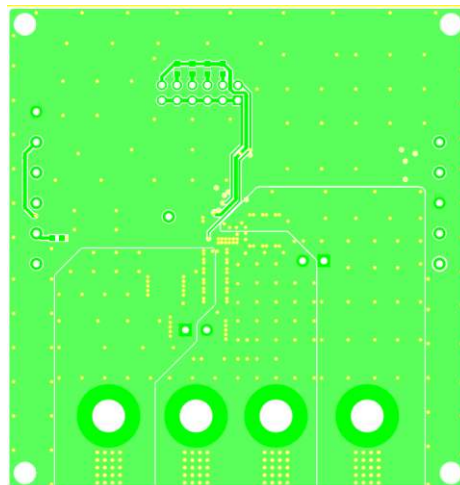

Figure 5: Bottom Layer

## QUICK-START GUIDE

The input voltage of the evaluation board can range from 8V to 16V. The minimum 8V input voltage is limited by the EN signal, which is derived from VIN through a resistor divider (R4 and R6). A lower input voltage (as low as 2.7V) can be set by fine-tuning the resistor divider values or by over-driving EN with an external control signal. The following is the procedure to turn on the evaluation board.

1. Connect the positive and negative terminals of the load to the VOUT and GND pins, respectively.
2. Preset the power supply output voltage between 8V and 16V and then turn the power supply off.
3. Connect the positive and negative terminals of the power supply output to the VIN and GND pins, respectively. Ensure that the power supply has a high enough current limit to supply the power.
4. Turn the power supply on. The EVQ8633B-LE-00A will start up automatically.
5. To use the enable function, apply a digital input to the EN pin. Drive EN above 1.5V to turn on the regulator. Drive EN below 1V to turn off the regulator.
6. Use R1 and R2 to set the output voltage with  $V_{FB} = 0.6V$ . Follow the Application Information section in the device datasheet to select the proper values for R1, R2, the inductor, and the output capacitor when the output voltage is changed.
7. The JP1 jumper can be used to select the operating frequency (600kHz, 800kHz, or 1000kHz) and light-load operation mode (pulse-skip mode, discontinuous conduction mode, or continuous conduction mode).

**NOTICE:** The information in this document is subject to change without notice. Please contact MPS for current specifications. Users should warrant and guarantee that third party Intellectual Property rights are not infringed upon when integrating MPS products into any application. MPS will not assume any legal responsibility for any said applications.