

LOC	DIST	P	F	ZONE	LTR	DESCRIPTION	DATE	APPD
AD	39				F	REV PER 0010-1175-95	12-28-96	JH
					G	REV PER 0G21-0081-98	18JUL98	MC
					H	REV PER 0G3C-0062-00	11FEB00	MZ
					H1	REV PER ECO-09-021826	05JAN10	AEG

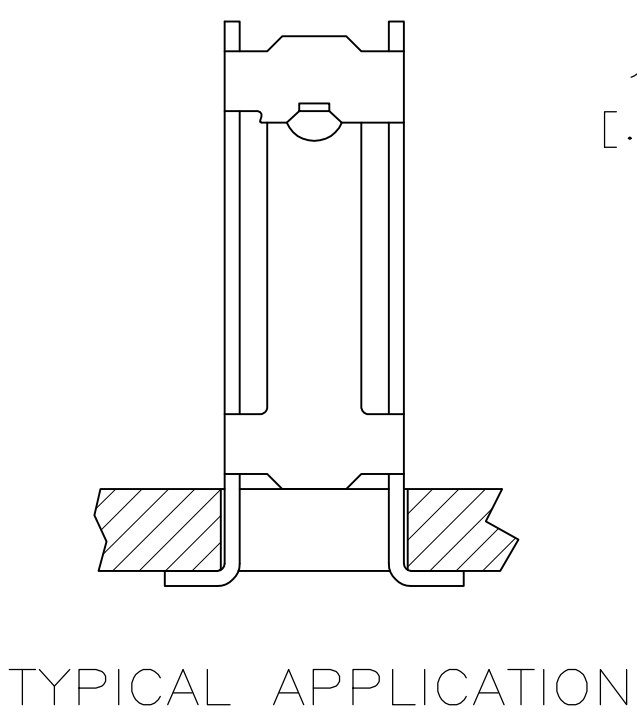

- 1 POINT OF MEASUREMENT FOR PLATING THICKNESS (INSIDE BEAMS).
- 2 SHEAR LINES DEFINE LOOSE PIECE PART.
- 3 "H" RECEPTACLE CENTERS MAY VARY DEPENDING ON REQUIREMENTS. MINIMUM NOMINAL CENTER SPACING BETWEEN ADJACENT RECEPTACLES IS 3.81±0.08[.150±.003].
- 4 GOLD FLASH OVER 0.00127[.000050] NICKEL ENTIRE TERMINAL, 0.00038[.000015] GOLD ON CONTACT AREA ONLY.
- 5 GOLD FLASH OVER 0.00127[.000050] NICKEL ENTIRE TERMINAL, 0.00076[.000030] GOLD ON CONTACT AREA ONLY.
- 6 0.00127[.000050] GOLD OVER 0.00127[.000050] NICKEL ENTIRE TERMINAL.
- 7 0.00076[.000030] GOLD OVER 0.00127[.000050] NICKEL ENTIRE TERMINAL.
- 8 0.00038[.000015] GOLD ON CONTACT AREA, 0.00254-0.00508[.000100-.000200] BRIGHT TIN-LEAD ON TERMINATION AREA, ALL OVER 0.00127[.000050] NICKEL ENTIRE TERMINAL.
- 9 0.00076[.000030] GOLD ON CONTACT AREA, 0.00254-0.00508[.000100-.000200] BRIGHT TIN-LEAD ON TERMINATION AREA, ALL OVER 0.00127[.000050] NICKEL ENTIRE TERMINAL.
- 10 0.00200 [.000079] MIN TIN.
- 11 OBSOLETE PARTS: OBSOLETE CIS STREAMLINING PER D.RENAUD/D.SINISI
- 12 OBSOLETE

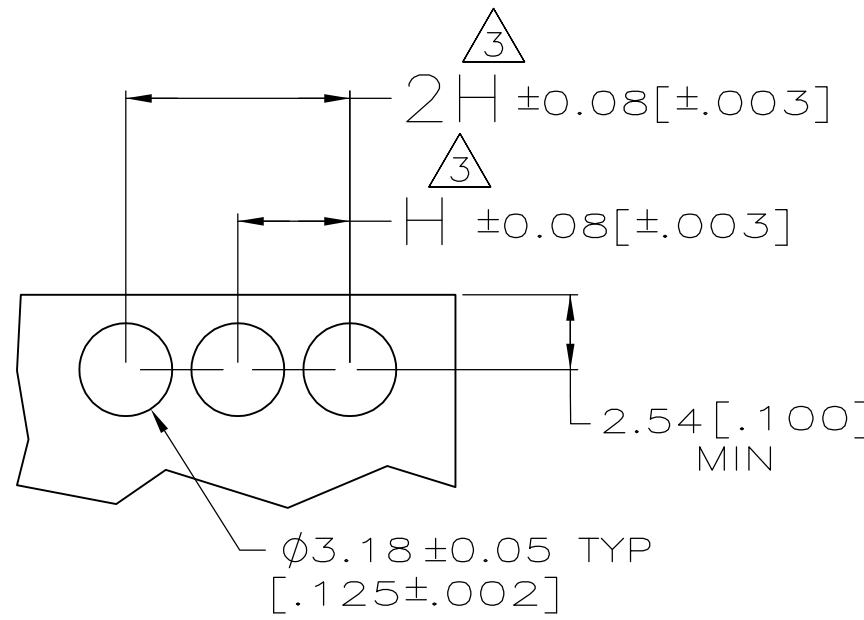
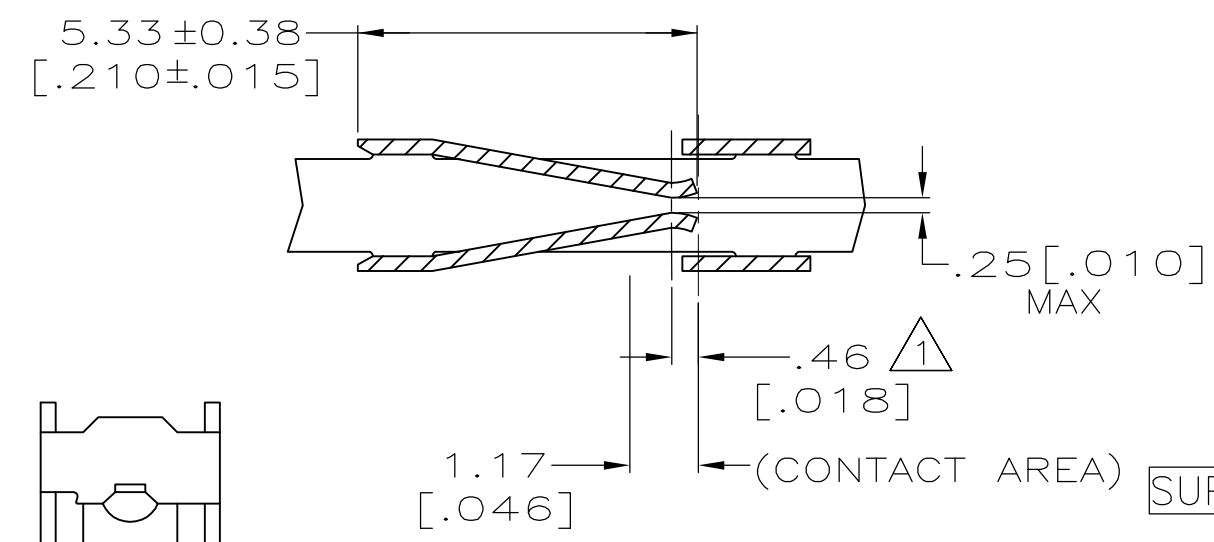
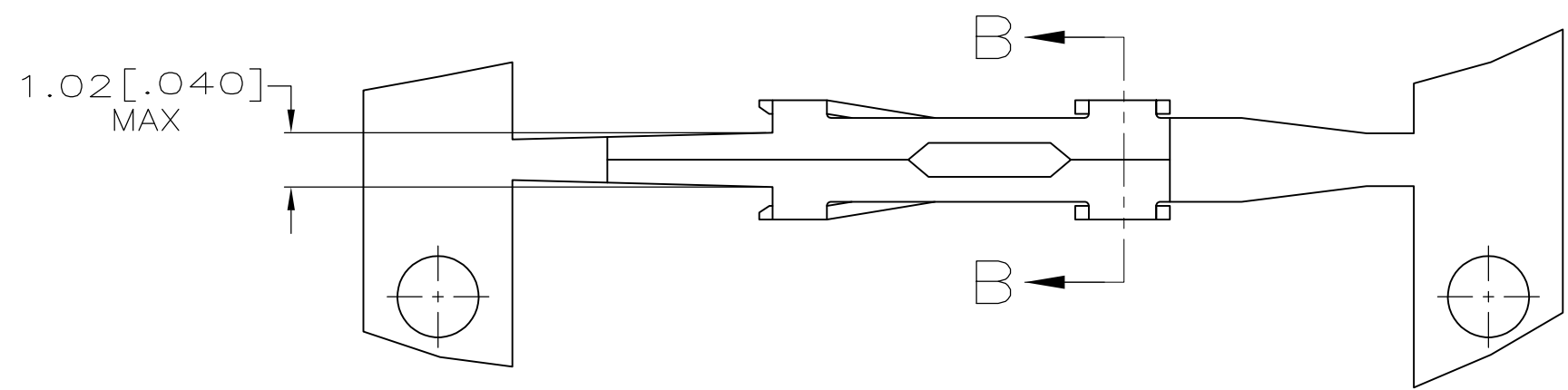
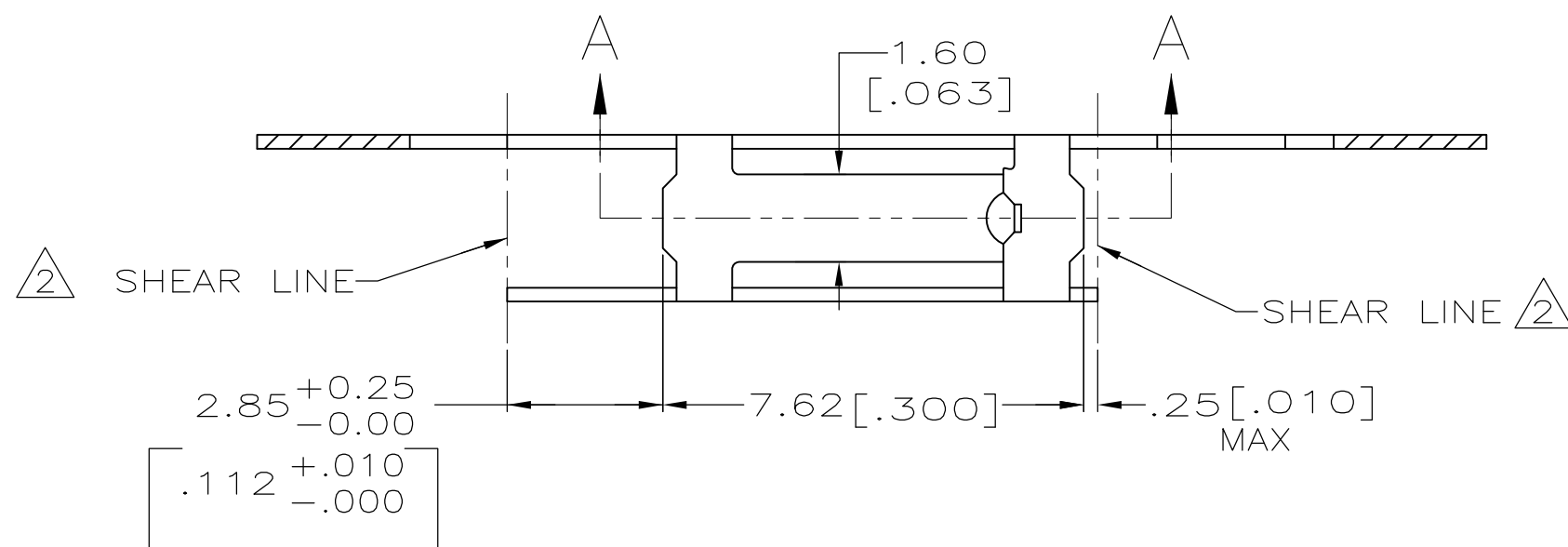
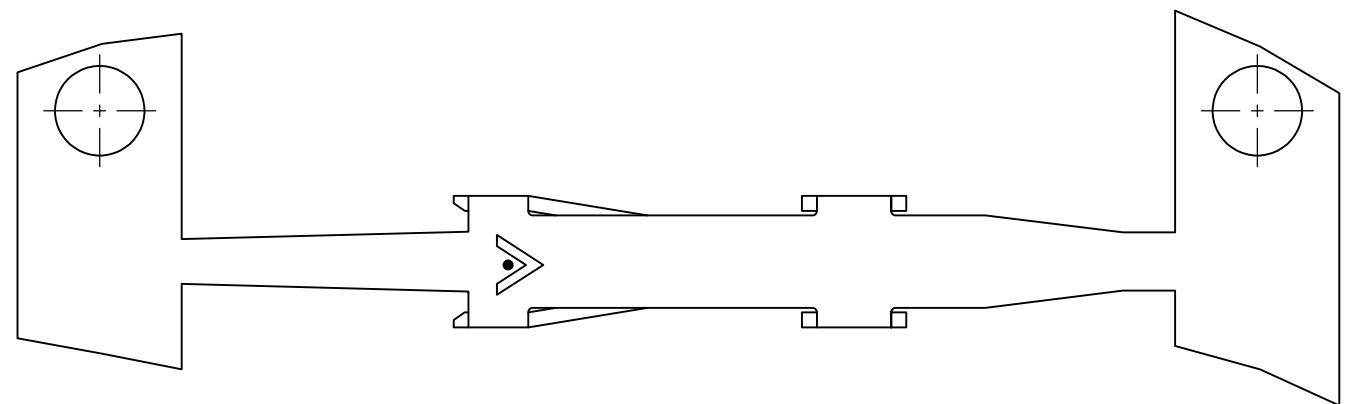
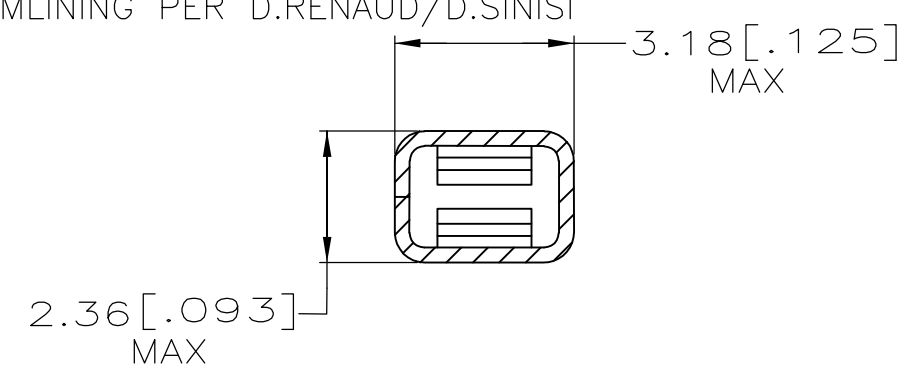

	MINIATURE			
		-	10	1-86477-1
OBSOLETE	MINIATURE	86480-7	9	1-86477-0
OBSOLETE	MINIATURE	86480-6	8	86477-9
OBSOLETE	MINIATURE	86480-5	7	86477-8
		-	-	-
OBSOLETE	MINIATURE	86480-4	6	86477-6
		-	-	-
	MINIATURE	86480-3	10	86477-3
	MINIATURE	86480-2	5	86477-2
	MINIATURE	86480-1	4	86477-1
	REELED FOR APPLICATOR	LOOSE PIECE PART NO	FINISH	PART NUMBER

DO NOT SCALE PRINT. UNLESS SPECIFIED DIMENSIONS IN mm [INCHES] TOLERANCES ON :		DR 12-28-96 E.BRANDBERG		AMP Incorporated Harrisburg, PA 17105-3608	
2 PLC DEC ± -		CHK 12-28-96 J. HERRINGTON			
3 PLC DEC ± 0.13[.005]		APPD 12-28-96 J. HERRINGTON		NAME RECEPTACLE, MOD I STANDARD PRESSURE, TYPE A	
ANGLES ± -		APPD 12-28-96 D. TROUT			
MATERIAL PHOS BRONZE		PRODUCT SPEC -		SIZE C	
FINISH SEE TABLE		APPLICATION SPEC -		CAGE CODE 00779	
		WEIGHT -		DRAWING NO C-86477	
				SCALE 8:1	
				SHEET 1 OF 1	

THIS DRAWING IS A CONTROLLED DOCUMENT FOR AMP INCORPORATED. IT IS SUBJECT TO CHANGE AND THE CONTROLLING ENGINEERING ORGANIZATION SHOULD BE CONTACTED FOR THE LATEST REVISION.