

1W

The GP Series is a line of miniature high voltage converters that provide outputs up to 6kV, positive or negative in a compact PCB mount package. This line features low power consumption, making it ideal for portable, battery powered applications. The isolated output is proportional to the input, and is linear from approximately 0.7 volts in. The isolated output allows for user selectable output polarity.

Excellent filtering techniques and a low noise quasi-sinewave oscillator provide clean, reliable DC to HV DC conversion with low ripple and low EMI/RFI. The GP Series units are component level converters that are easy to integrate, low cost, and come with decades of field proven reliability.

Features

- Output voltages from 200V to 6kV
- Output voltage proportional to input
- Low turn-on voltage 0.7VDC
- Input to output isolation
- Dual output models
- No minimum load
- 3 Year warranty

Models & Ratings

Model Number ^(2,3)	Output Voltage	Output Current	Input Current		Ripple
			No Load	Full Load	
GP02	0 to 200V	5mA	<45mA	<150mA	<1.75%
GP03R	0 to 300V	3.3mA	<45mA	<125mA	<0.5%
GP05	0 to 500V	2mA	<15mA	<125mA	<0.5%
GP06R	0 to 600V	1.67mA	<15mA	<125mA	<0.5%
GP12	0 to 1200V	0.84mA	<25mA	<125mA	<0.75%
GP15	0 to 1500V	0.66mA	<20mA	<125mA	<0.75%
GP25	0 to 2500V	0.4mA	<30mA	<130mA	<1%
GP30R	0 to 3000V	0.34mA	<40mA	<130mA	<1%
GP40 ⁽³⁾	0 to 4000V	0.25mA	<50mA	<130mA	<1%
GP50 ⁽³⁾	0 to 5000V	0.2mA	<75mA	<150mA	<1.5%
GP60 ⁽³⁾	0 to 6000V	0.167mA	<85mA	<175mA	<1%

Notes:

1. All orderable part numbers are listed above.
2. R suffix is used as a RoHS indicator for legacy models.

3. Models GP40, GP50, and GP60 do not have internal bleeder resistors on the output. Provisions must be made externally to discharge the output capacitors.

DC-HVDC CONVERTER



Typical Applications



- Mass Spectrometry
- Electrostatic Chucks
- Electrophoresis
- Capacitor Charging
- Particle Counter
- Ignition/Spark
- Sustaining Ion Pumps

Dimensions

1.50" x 1.50" x 0.63" (38.1 x 38.1 x 16.0mm)

Input

Characteristic	Minimum	Typical	Maximum	Units	Notes & Conditions
Input Voltage	0.7		12	VDC	
Input Current, Full Load			175	mA	See Models & Ratings table
Input Current, No Load			85	mA	See Models & Ratings table

Output

Characteristic	Minimum	Typical	Maximum	Units	Notes & Conditions
Output Voltage			6000	VDC	See Models & Ratings table
Output Current			5	mA	See Models & Ratings table
Output Voltage Tolerance		±3		%	At Max Vout, Full Load
Minimum Load	No minimum load required				
Regulation	Unregulated, Output is proportional to input. See application notes				
Ripple and Noise	0.5		1.75	%	See Models & Ratings table
Response Time		20		msec	0 to Max Vout, Full load [G01 to G60]

General

Characteristic	Minimum	Typical	Maximum	Units	Notes & Conditions
Isolation: Input to Output			3500	V	< ±3500 Bias
Switching Frequency	60		400	kHz	
Construction	Case material is Diallyl Phthalate (DAP). UL 94V-0 rated solid vacuum encapsulation				
Mean Time Between Failure	2.31			Mhrs	Bellcore TR 332

Environmental

Characteristic	Minimum	Typical	Maximum	Units	Notes & Conditions
Operating Temperature (case)	-20		+70	°C	
Storage Temperature	-20		+105	°C	
Cooling	Natural convection				
Humidity			95	%RH	Non-condensing

Notes:

- Maximum rated output current is available at maximum rated output voltage and derates linearly as input voltage is decreased.
- Output voltage is load dependent. Under light or no-load conditions, reduce the input voltage so maximum rated output voltage is not exceeded.
- Specifications after 30 minute warm-up, full load, at 25°C unless otherwise indicated.
- Proper thermal management techniques are required to maintain safe case temperature at maximum power output.

Mechanical Details

Top View

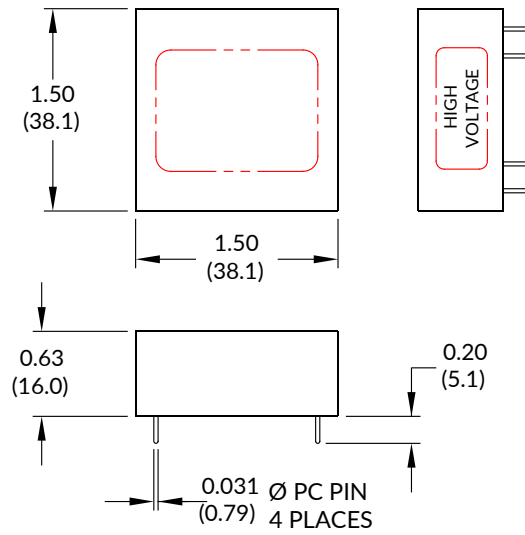

Pin	Function
1	(+) Input
2	(-) Input
3	(+) Output
4	(-) Output

PCB Layout - Top View

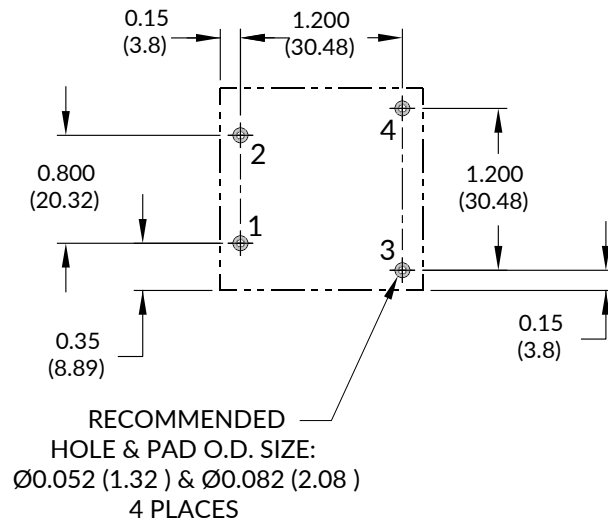

Notes:

1. All dimensions are in inches (mm)
2. Weight 1.5oz (43g)

3. Tolerance: X.XX±0.02 (0.51)
4. Pin Tolerance: ±0.005 (0.127)

Block Diagram

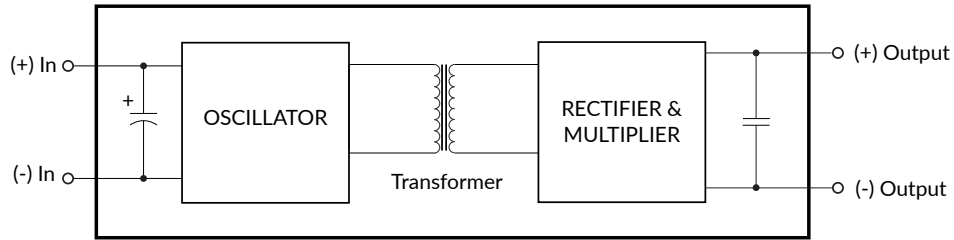

Application Notes

Positive Output

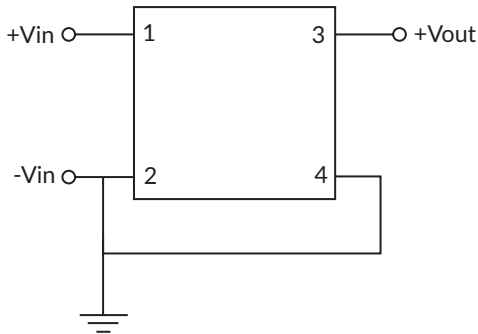

Negative Output

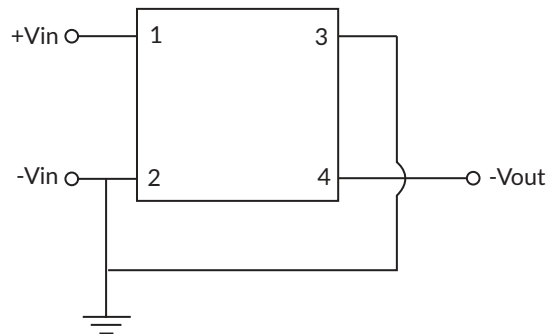

Application Notes

Output Voltage vs. Input Voltage

