

4

3

2

1

THIS DRAWING IS UNPUBLISHED. RELEASED FOR PUBLICATION
© COPYRIGHT ALL RIGHTS RESERVED.

LOC	DIST	REVISIONS			
P	LTR	DESCRIPTION	DATE	DWN	APVD
	C2	ECR-16-009824	28JUL2016	GK	SD

REPLACED BY OCEAN STYLE APPLICATOR PART NUMBER 2836294-1

FOR REPLACEMENT PARTS FOR APPLICATOR 567072-2 REFER TO ADDITIONAL PAGE(S). SPARE PARTS KIT (IF LISTED) WILL REMAIN AVAILABLE.

THE REPLACEMENT OCEAN STYLE APPLICATOR HAS THE SAME TERMINATOR/PRESS INTERFACE AS APPLICATOR 567072-2

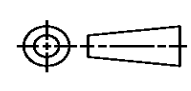
THIS DRAWING IS A CONTROLLED DOCUMENT.		DWN	GOPALAKRISHNA HV		
DIMENSIONS:		CHK	GOPALAKRISHNA HV		
		TOLERANCES UNLESS OTHERWISE SPECIFIED:		APVD	
		0 PLC ± 1 PLC ± 2 PLC ± 3 PLC ± 4 PLC ± ANGLES ±		STOUGH DALE	
MATERIAL		PRODUCT SPEC		NAME	
FINISH		APPLICATION SPEC		MINIATURE QUICK CHANGE APPLICATOR SIDE FEED(110 SERIES F)	
		WEIGHT	SIZE	CAGE CODE	DRAWING NO
			A3		©- 567072-2
		CUSTOMER DRAWING		SCALE	SHEET 1 OF 2 REV C2



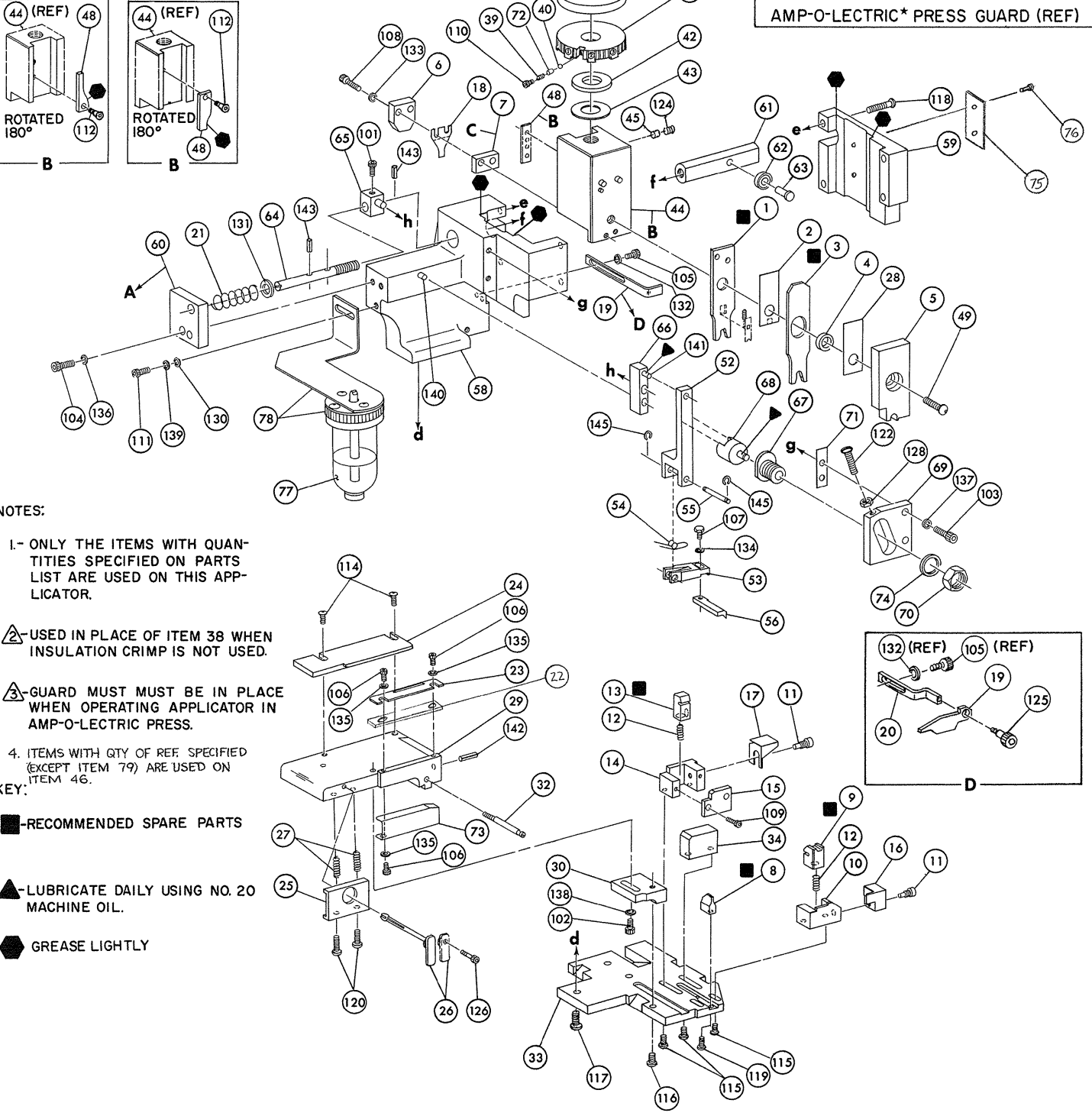
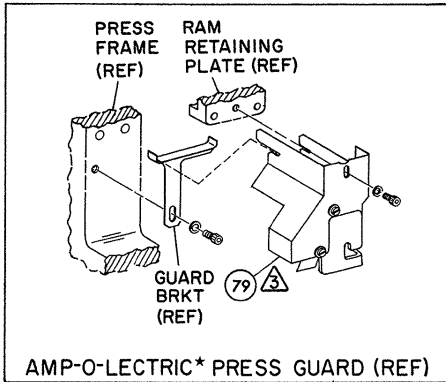
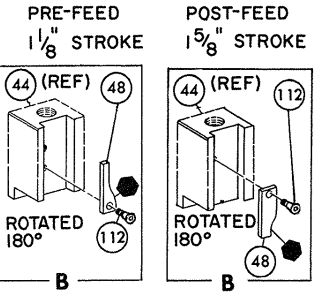
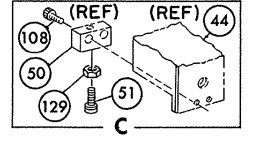
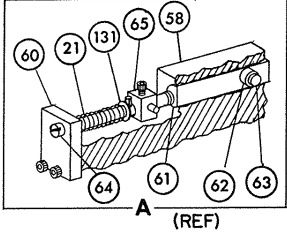

- NOTES:**
- 1- ONLY THE ITEMS WITH QUANTITIES SPECIFIED ON PARTS LIST ARE USED ON THIS APPLICATOR.
 - 2- USED IN PLACE OF ITEM 38 WHEN INSULATION CRIMP IS NOT USED.
 - 3- GUARD MUST BE IN PLACE WHEN OPERATING APPLICATOR IN AMP-O-LECTRIC PRESS.
 - 4. ITEMS WITH QTY OF REF SPECIFIED (EXCEPT ITEM 79) ARE USED ON ITEM 46.
- KEY:**
- -RECOMMENDED SPARE PARTS
 - ▲ -LUBRICATE DAILY USING NO. 20 MACHINE OIL.
 - ◆ -GREASE LIGHTLY

REF	21045-3	RING, RETAINING 'C' (.187 DIA) FEED FINGER PIN	145	REF	454220-1	CAP, HOUSING	59
	3-354779-9	PIN, WIRE DISC (.3185) C	144	REF	454485-1	HOUSING	58
REF	5-21028-1	PIN, SLOT SPR (.125 DIA X .50) ADJ ROD	143				57
1	4-21028-0	PIN, SLOT SPR (.093 DIA X .75) STR G PLATE	142	1	690542-2	PAWL, FEED	56
REF	1-21030-1	PIN, DOWEL (.187 DIA X .50) LEVER	141	REF	240624-1	PIN, FEED FINGER	55
REF	1-21030-6	PIN, DOWEL (.187 DIA X 1.25) HOUSING	140	REF	691499-1	SPRING, FEED FINGER	54
	21024-5	WASHER, LOCK (NO 10) LUB ASSY	139	REF	690541-1	FINGER, FEED	53
1	21024-5	WASHER, LOCK (NO 10) STRIP GUIDE ADJ BLOCK	138	REF	455679-1	LEVER, TERMINAL FEED ARM	52
REF	21024-5	WASHER, LOCK (NO 10) ADJ PLATE	137	1	811242-2	BUMPER, HOLDDOWN	51
REF	21024-5	WASHER, LOCK (NO 10) FEED GUIDE ROD	136	1	690753-1	SPACER, TONKER	50
3	21024-2	WASHER, LOCK (NO 4) FRONT STRIP GUIDE	135	1	7-21002-9	BOLT, CRIMPER	49
1	21024-4	WASHER, LOCK (NO 8) FEED FINGER	134	1	690602-5	CAM PRE FEED 1/8 STROKE	48
2	21024-4	WASHER, LOCK (NO 8) DEPRESSOR	133				47
1	21024-4	WASHER, LOCK (NO 8) STRIPPER	132	1	459456-1	APPLICATOR, BASIC (SUB ASSY)	46
REF	21899-4	WASHER, FLAT (5/16 DIA) SCREW ADJ	131	1	690191-1	PLUG, NYLON	45
	21899-2	WASHER, FLAT (NO 10) LUB ASSY	130	1	455673-1	RAM	44
1	21018-5	NUT, HEX MACH (6-32) HOLDDOWN	129	1	690125-1	WASHER, LAMINATED	43
REF	21018-5	NUT, HEX MACH (6-32) FEED ADJ	128	1	690124-1	WASHER, RAM	42
2	3-354779-5	PIN, WIRE DISC (.3165) B	127			DISC, SPACER	41
—	22353-8	SCR, SHLD. (.187 DIA X .250 LG) DRAG LEVER	126	1	23241-6	BALL, STEEL	40
1	456567-1	SCR, SHLD. (.188 DIA X .125 LG) STRIPPER	125	1	690170-1	SPRING, COMPRESSION	39
1	21009-2	SCR, SKT SET (1/4-20 X .25) (LOC-WEL) RAM	124	1	690142-1	DISC, INSULATION	38
2	2-354779-4	PIN, WIRE DISC (.3110) A	123	1	354777-1	DISC, WIRE	37
REF	6-23715-5	SCR, PAN. HD MACH (6-32 X 1.50) FEED ADJ	122	1	22480-5	WASHER, SPRING	36
			121	1	690212-1	POST, RAM	35
2	2-21002-9	SCR, BUT HD SKT CAP (10-32 X .75) DRAG	120	1	690786-6	SUPPORT, TERMINAL	34
1	22733-8	SCR, BUT HD SKT CAP (8-32 X .38) (LOC-WEL) ANVIL	119	REF	455675-1	PLATE, BASE	33
REF	2-21002-9	SCR, BUT HD SKT CAP (10-32 X .75) CAP	118	1	690432-3	SCREW, ADJUSTMENT	32
REF	17177-1	SCR, BUT HD SKT CAP (1/4-20 X .62) HOUSING	117	1	986950-1	WASHER, FLAT PRECISION	31
REF	2-21002-7	SCR, BUT HD SKT CAP (10-32 X .50) SG ADJ BLOCK	116	REF	455689-1	BLOCK, STRIP GUIDE ADJ	30
4	2-21002-2	SCR, BUT HD SKT CAP (8-32 X .50) SHEAR	115	1	455671-1	PLATE, STRIP GUIDE	29
2		SCR, BUT HD SKT CAP (8-32 X) R STRIP GUIDE	114	1	1-455888-4	SPACER, FRONT SHEAR DEPRESSOR	28
			113	2	1-22284-0	SPRING, DRAG	27
1	2-21003-0	SCR, FLAT HD SKT CAP (6-32 X .50) CAM	112	1	690546-1	LEVER, DRAG RELEASE	26
	3-21000-4	SCR, SKT HD CAP (10-32 X .38) LUBRICATOR ASSY	111	1	240792-1	DRAG, STOCK	25
1	23030-1	SCR, SKT HD CAP (6-32 X .25) (LOC-WEL) CP DISC	110	1	7690504-3	GUIDE STRIP (REAR)	24
		SCR, SKT HD CAP (6-32 X) REAR SHEAR PLATE	109	1	690438-1	GUIDE, STRIP (FRONT)	23
		SCR, SKT HD CAP (8-32 X) DEPRESSOR	108	1	463157-1	SPACER, FT. STRIP GUIDE	22
1	2-22603-0	SCR, HEX HD MACH (8-32 X .31) FEED FINGER	107	REF	4-22284-9	SPRING, FEED RETURN	21
3	1-21000-3	SCR, SKT HD CAP (4-40 X .25) F STRIP GUIDE	106	1	458950-1	ARM, STRIPPER	20
1	2-21000-7	SCR, SKT HD CAP (8-32 X .50) STRIPPER	105	1	458949-1	STRIPPER	19
REF	3-21000-7	SCR, SKT HD CAP (10-32 X .75) FEED ROD GUIDE	104			HOLDER, TERMINAL	18
REF	3-21000-6	SCR, SKT HD CAP (10-32 X .62) FEED ADJ BLOCK	103			GUARD, CHIP (REAR)	17
1	3-21000-4	SCR, SKT HD CAP (10-32 X .38) SG ADJ BLOCK	102	1	691667-1	GUARD, CHIP (FRONT)	16
REF	3-21000-4	SCR, SKT HD CAP (10-32 X .38) PIVOT BLOCK	101	—		PLATE, SHEAR (REAR)	15
REF	455749-1	GUARD, WINDOW	79	—		HOLDER, SHEAR (REAR)	14
1	1-465184-0	LUBRICATOR ASSY	78	—		SHEAR, FLOAT (REAR)	13
		OIL, LUBRICATING	77	1	5-22280-0	SPRING, SHEAR	12
2	21017-2	SCR, DRIVE (#2x.19) I.D. PLATE	76	1	690461-1	STOP, SHEAR	11
1	461264-1	PLATE, IDENTIFICATION	75	1	690459-1	HOLDER, SHEAR (FRONT)	10
REF	458109-1	WASHER, SPECIAL	74	1	454276-1	SHEAR, FLOAT (FRONT)	9
1	454877-3	PLATE, STRIP GUIDE COVER	73	1	1-803653-3	ANVIL	8
1	690603-1	SPRING, ASSIST	72			SPACER, DEPRESSOR (REAR)	7
REF	690517-1	SPACER	71			DEPRESSOR, SHEAR (REAR)	6
	22594-8	NUT, HEX	70	1	1-455889-3	DEPRESSOR, SHEAR (FRONT)	5
	240628-1	PLATE, ADJUSTMENT	69	1	238011-4	SPACER, TUBULAR, INS CRIMPER	4
	240626-1	SHAFT, PIVOT	68	1	693453-1	CRIMPER, INSULATION	3
	240633-1	BUSHING	67	1	455888-7	SPACER, CRIMPER	2
	455680-1	LEVER, INTERMEDIATE	66	1	1-456407-1	CRIMPER, WIRE	1
	240629-1	BLOCK, PIVOT	65				
	240632-2	SCREW, ADJUSTMENT FEED ROD	64				
	240659-3	PIN, CAM ROLLER	63				
	240658-1	ROLLER, CAM	62				
	454398-2	ROD, FEED	61				
REF	454178-1	GUIDE, FEED ROD	60				

QTY	PART NO	DESCRIPTION	ITEM NO	
		REMARKS	NO	REV
			TO APPLY TERMINAL	114-2036
		APPL USED ON MACHINE PART NO	MACH SERIAL NO	DISTRIBUTION
		CUSTOMER NAME	APPL SERIAL NO	ORIGINAL
		ADDRESS	PURCHASE ORDER	CUSTOMER COPY
		CITY	ENG APP	FIELD ENG COPY

CRIMPING DATA					APPLICATOR WILL APPLY
PAD LTR	CRIMP HEIGHT	WIRE SIZE	STRIP LENGTH		63138
A	.058	18			63261
B	.054	20			1217634
C	.052	22			
D	NOT USED				
CRIMP	SIZE	TYPE	FEED	APPL INST	
WIRE	.120	F	.480	A1 8040	
INSUL	.160	F			
WIRE RANGE	#18-22	INSULATION RANGE	.070-.128	PRESS NO	565435-5
REMARKS AMP-O-LECTRIC PRE-FEED					
I.D. PLATE (REF) 4612641					
SET UP GAGE 10-1					
458637-11182					
C1	ECR-06-029591	AY/TC	4-06	DR 42931	APP 6181
C	0150-09-14-02	AY/TC	7-02	JE BEATTY	11/19/99
B	0150-7512-97	PS/BL	2-97	CHK 2-99	REL 1/20/03
A	0150-10821-510	LEF/CL	1/20/03	LEF 1/20/03	
C1	REV PER EON 2479	3/2/2013			
NAME L MINIATURE QUICK CHANGE APPLICATOR					
SIDE FEED (110 SERIES FASTON TAB)					



LOC A D NO 567072-2 REV C1