

PRODUCT NO.	DESCRIPTION
73474-101	HEAT STAKE VERSION
73474-101LF	HEAT STAKE VERSION

**FRONT VIEW**

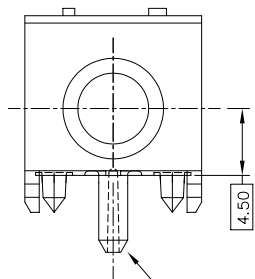

HEAT-STAKE PEG VERSION

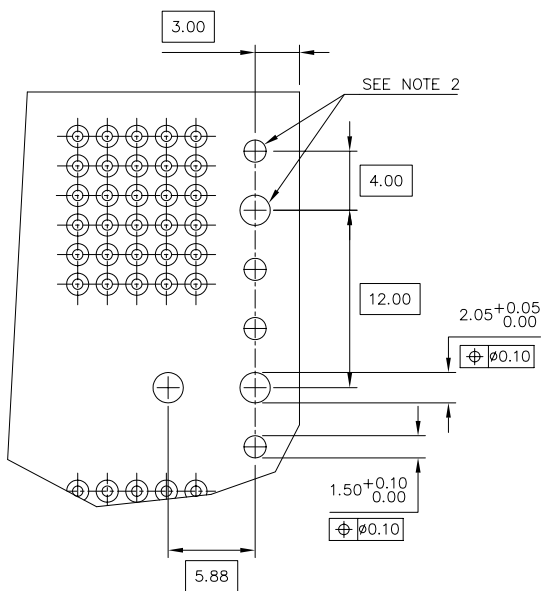
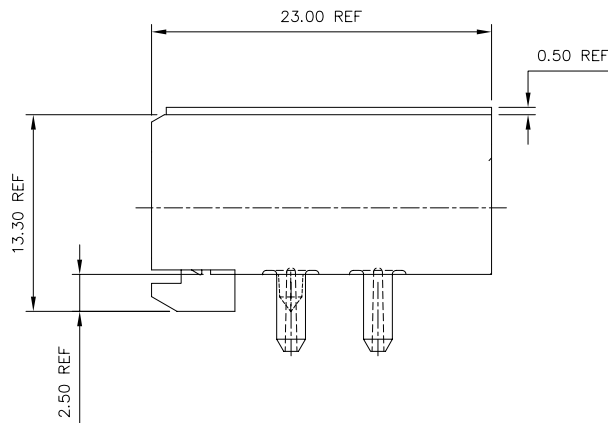

REQUIRED PC BOARD LAYOUT  
COMPONENT SIDE

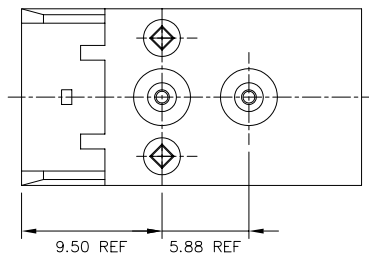

**NOTES:**

- HOUSING MATERIAL: LCP, 30% GLASS FILLED  
FLAME RETARDANT PER UL 94V-0.  
COLOR: NATURAL
- INDICATED HOLES ARE UNPLATED.
- SEE SHEET 2 FOR PRESS-PEG VERSION.  
SEE SHEET 3 FOR SCREW-DOWN VERSION.
- THE PRODUCTS WHERE THE PART NUMBER ENDS IN "LF" MEET THE EUROPEAN UNION DIRECTIVES AND OTHER COUNTRY REGULATIONS AS DESCRIBED IN GS-22-008.  
ALL PRODUCTS WILL WITHSTAND EXPOSURE TO 260°C FOR 60 SECONDS IN A CONVECTION, INFRA-RED OR VAPOR PHASE REFLOW OVEN.

mat'l. code		surface		tolerance		projection		product family	
SEE NOTES		ISO 1302 ✓		ISO 406 ISO 1101		mm		METRAL ACC	
ltr	ecn	no	dr	date	tolerances unless otherwise specified		title		
G	v11668	LSS	6/12/01		angles	linear	xx ±.01/3		RECEPTACLE GUIDE
H	v12868	CGD	1/02/02				xxx ±.005/.13		MODULE, 5 ROW
J	v05-0007	TAB	1/11/05		σ±2'		xxxx ±.0020/.050		scale 1:1
K	v05-0223	TAB	3/11/05	dr	M. FETROW		5/19/97		dwg no
L	v05-0730	DAI	8/04/05	enr	c. PENDLETON		5/19/97		sheet 1 of 5
M	m05-0231	MHT	10/28/05	chr	c. PENDLETON		5/19/97		size
N	M06-0286	MNR	7/27/06	app	c. PENDLETON		5/19/97		A3
sheet	revision	N	N	N	N	N	FCJ		
index	sheet	1	2	3	4	5	type Product Customer Drawing		

PRODUCT NO.	DESCRIPTION
73474-201	PRESS-PEG VERSION
73474-201LF	PRESS-PEG VERSION

**FRONT VIEW**

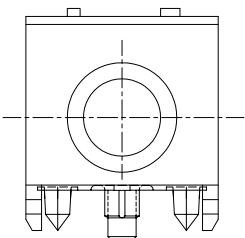

PRESS PEG VERSION

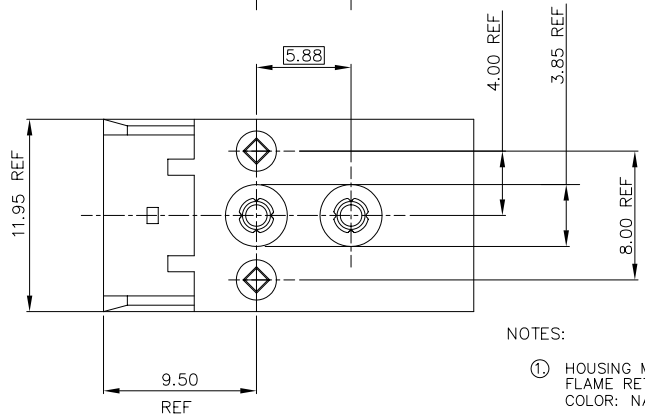
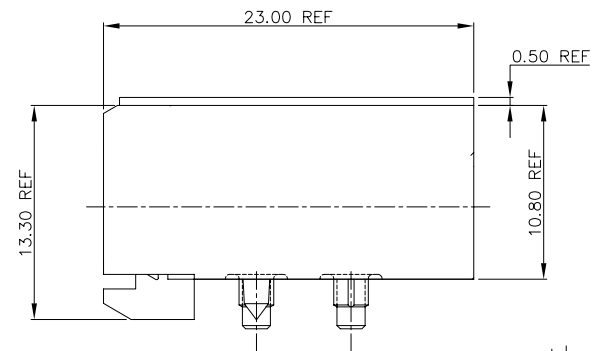

**NOTES:**

- ① HOUSING MATERIAL: LCP, 30% GLASS FILLED  
FLAME RETARDANT PER UL 94V-0.  
COLOR: NATURAL
- ② INDICATED HOLES ARE UNPLATED.
- 3. THIS SHEET SHOWS DIMENSIONS OF OPTIONAL PRESS-PEG ONLY.  
FOR ALL OTHER DIMENSIONS AND REQUIREMENTS SEE SHEET 1.  
FOR HEAT-STAKE VERSION SEE SHEET 1, FOR SCREW-DOWN  
VERSION, SEE SHEET 3.

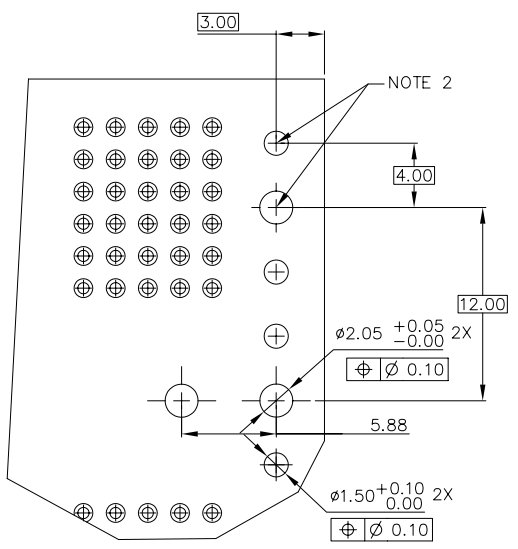

REQUIRED PC BOARD LAYOUT  
COMPONENT SIDE

mat'l. code SEE NOTES		surface ISO 1302 ✓	tolerance ISO 406 ISO 1101	projection 	product family METRAL ACC
ltr	ecn no	dr	date	tolerances unless otherwise specified	title RECEPTACLE GUIDE MODULE, 5 ROW
N				angles linear xx ±.01/.3 xxx ±.005/.13 σ±2' xxx ±.0020/.050	scale 1:1
		dr	M. FETROW	5/19/97	
		enr	C. PENDLETON	5/19/97	
		chr	C. PENDLETON	5/19/97	
		app	C. PENDLETON	5/19/97	
sheet index	revision sheet				dwg no 73474 sheet 2 of 5 size A3 type Product Customer Drawing



Copyright FCI

PRODUCT NO.	DESCRIPTION
73474-301	SCREW DOWN VERSION
73474-301LF	SCREW DOWN VERSION

**FRONT VIEW**

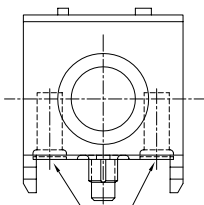

SCREW DOWN VERSION

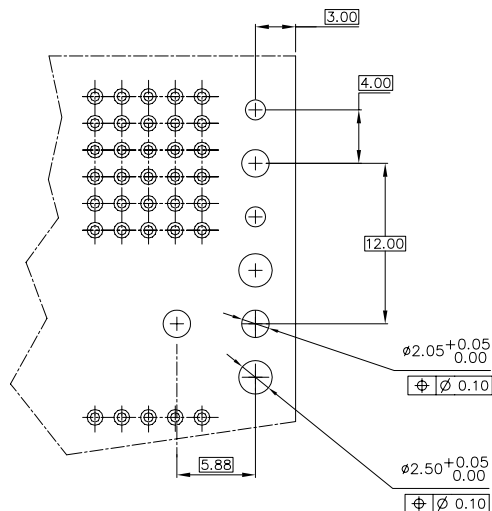
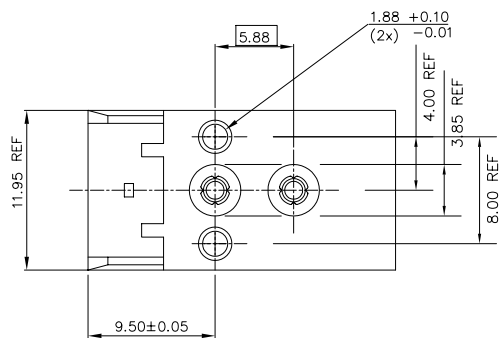
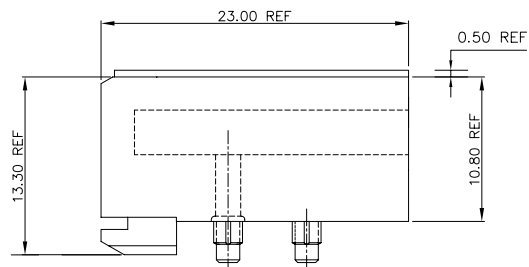

REQUIRED P.C. BOARD LAYOUT COMPONENT SIDE

NOTES:

- HOUSING MATERIAL: LCP, 30% GLASS FILLED FLAME RETARDANT PER UL 94V-0. COLOR: NATURAL
- THIS SHEET SHOWS DIMENSIONS OF OPTIONAL SCREW-DOWN ONLY. FOR ALL OTHER DIMENSIONS AND REQUIREMENTS SEE SHEET 1. FOR HEAT-STAKE VERSION SEE SHEET 1, FOR PRESS-PEG, SEE SHEET 2.
- TWO MOUNTING SCREWS, P/N 63787-001, OR 63787-001LF FOR 73474-301LF, FOR MAX PCB THICKNESS 2.4mm [0.094"]. P/N 63787-002 OR 63787-002LF FOR 73474-301LF MAX PCB THICKNESS 3.2mm [0.126"]. MUST BE ORDERED SEPARATELY
- THE MATING CONNECTOR FOR THIS APPLICATION MUST USE A WALL-LESS HEADER HOUSING, P/N 63735-101, TO AVOID INTERFERENCE WITH MOUNTING SCREW HEADS.



FCIconnect.com

Copyright FCI

mat'l. code SEE NOTES		surface ISO 1302 ✓	tolerance ISO 406 ISO 1101	projection 	product family METRAL ACC
ltr	ecn no/dr	date	tolerances unless otherwise specified		title RECEPTACLE GUIDE MODULE, 5 ROW
N			angles	linear xx ±.01/.3 xxx ±.005/.13 xxxx ±.0020/.050	mm ←→
			dr	M. FETROW 5/19/97	scale 1:1
			enr	C. PENDLETON 5/19/97	FCI
			chr	C. PENDLETON 5/19/97	
			app	C. PENDLETON 5/19/97	
sheet index	revision sheet				dwg no 73474 sheet 3 of 5 size A3
					type Product Customer Drawing

PRODUCT NO.	DESCRIPTION
73474-302	SCREW DOWN VERSION
73474-302LF	SCREW DOWN VERSION

**FRONT VIEW**

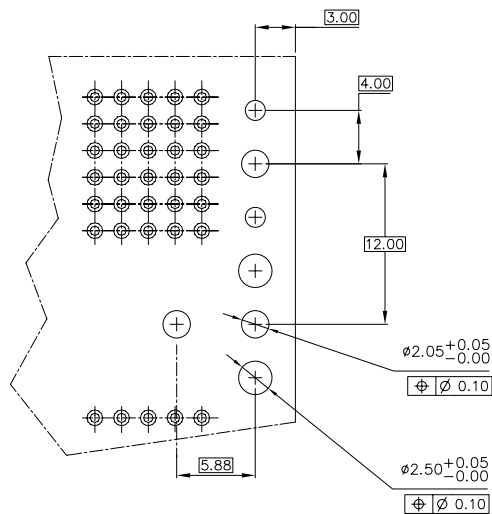
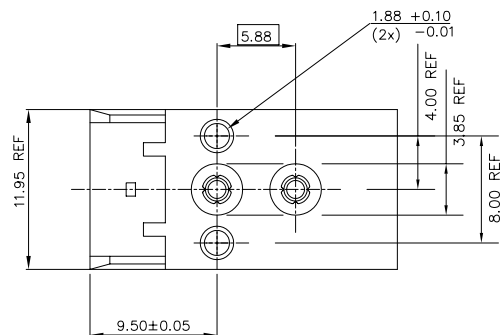
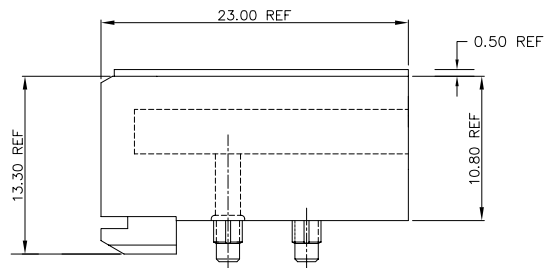
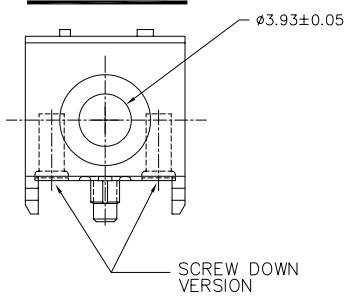

REQUIRED P.C. BOARD LAYOUT  
COMPONENT SIDE

**NOTES:**

- HOUSING MATERIAL: LCP, 30% GLASS FILLED  
FLAME RETARDANT PER UL 94V-0.  
COLOR: NATURAL
- THIS SHEET SHOWS DIMENSIONS OF OPTIONAL SCREW-DOWN ONLY.  
FOR ALL OTHER DIMENSIONS AND REQUIREMENTS SEE SHEET 1.  
FOR HEAT-STAKE VERSION SEE SHEET 1, FOR PRESS-PEG,  
SEE SHEET 2.
- TWO MOUNTING SCREWS, P/N 63787-001, OR 63787-001LF FOR  
73474-301LF, FOR MAX PCB THICKNESS 2.4mm [0.094"].  
P/N 63787-002 OR 63787-002LF FOR 73474-301LF MAX  
PCB THICKNESS 3.2mm [0.126"].  
MUST BE ORDERED SEPARATELY
- THE MATING CONNECTOR FOR THIS APPLICATION MUST USE A  
WALL-LESS HEADER HOUSING, P/N 63735-101, TO AVOID  
INTERFERENCE WITH MOUNTING SCREW HEADS.

FCI  
FCIconnect.com

Copyright FCI

mat'l. code		surface		tolerance		projection		product family	
SEE NOTES		ISO 1302 ✓		ISO 406 ISO 1101		mm		METRAL ACC	
ltr	ecn	no	dr	date	tolerances unless otherwise specified				
N					angles	linear	xx ±.01/.3	title	
					0°±2'		xxx ±.005/.13	RECEPTACLE GUIDE	
							xxxx ±.0020/.050	MODULE, 5 ROW	
			dr	M. FETROW	5/19/97	scale 1:1		dwg no	
			enr	C. PENDLETON	5/19/97	FCI		sheet 4 of 5 size	
			chr	C. PENDLETON	5/19/97			73474 A3	
			app	C. PENDLETON	5/19/97			type Product Customer Drawing	
sheet	revision								
index	sheet								

PRODUCT NUMBER	DESCRIPTION
73474-401M	PRESS PEG VERSION
73474-401	PRESS PEG VERSION
73474-401LF	PRESS PEG VERSION

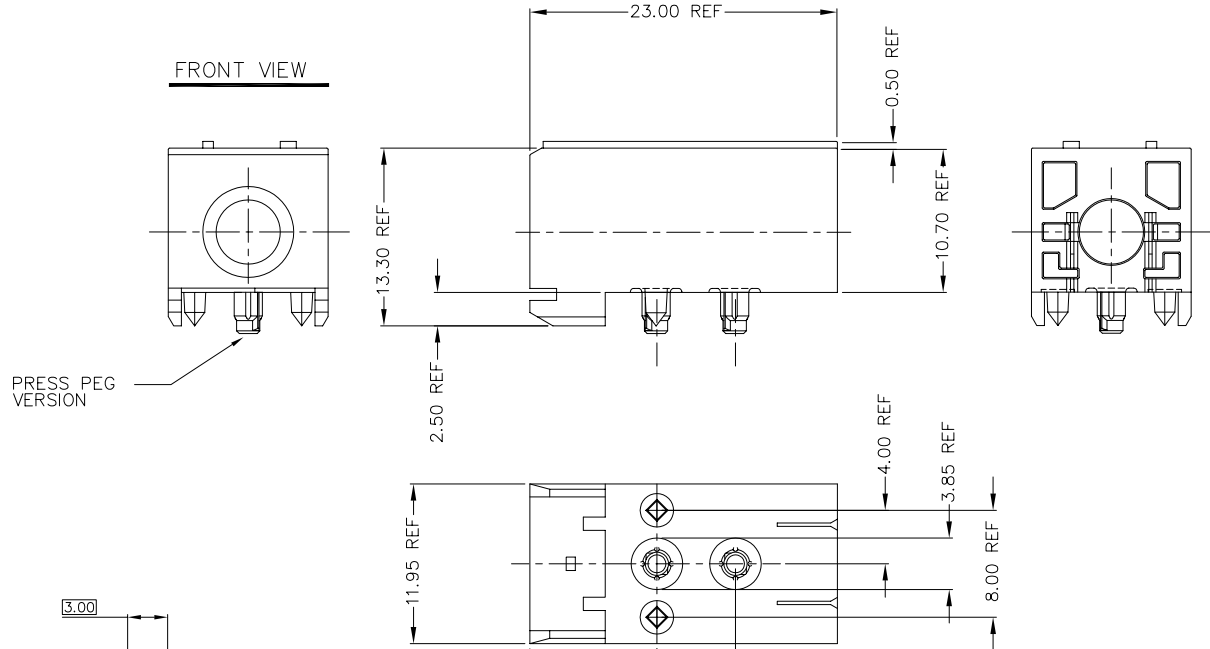

NOTES:

- HOUSING MATERIAL: LCP, 30% GLASS FILLED  
FLAME RETARDANT PER UL 94V-0.  
COLOR: NATURAL
- INDICATED HOLES ARE UNPLATED.
- THIS SHEET SHOWS DIMENSIONS OF OPTIONAL PRESS-PEG ONLY.  
FOR ALL OTHER DIMENSIONS AND REQUIREMENTS SEE SHEET 1.  
FOR HEAT-STAKE VERSION SEE SHEET 1, FOR SCREW-DOWN  
VERSION, SEE SHEET 3.

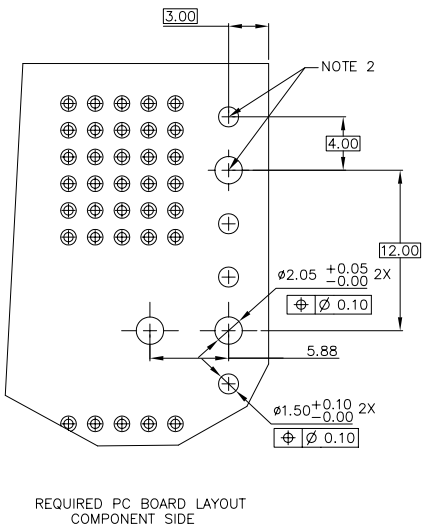

mat'l. code		surface	tolerance	projection	product family
SEE NOTES		ISO 1302 ✓	ISO 406 ISO 1101		METRAL ACC
ltr	ecn no	dr	date	title	
N				RECEPTACLE GUIDE MODULE, 5 ROW	
		angles	linear	mm	scale 1:1
		$\sigma \pm 2'$	xxx ±.01/.3 xxx ±.005/.13 xxxx ±.0020/.050		
		dr	M. FETROW	5/19/97	dwg no
		enr	C. PENDLETON	5/19/97	sheet 5 of 5
		chr	C. PENDLETON	5/19/97	size
		app	C. PENDLETON	5/19/97	A3
					type Product Customer Drawing
sheet index	revision sheet				

FCI  
FCIconnect.com

Copyright FCI