



R701P

MICROSTEPPING DRIVER

FEATURES & BENEFITS

REPLACES R701 MICROSTEPPING DRIVE

- 10 microstepping driver
- Common Ground or Common + 5 Volts Input Option Available
- Optically isolated Step, Direction, and Disable/Enable inputs
- Automatic Current Reduction
- Adjustable trimpot for noise and vibration reduction
- Operates from 18 to 80 VDC
- Selectable Driver Peak Current Ranges: 0 to 7 Amps
- Low Power Dissipation from 1 to 12 Watts (1 to 7 Amps)
- Excellent sinusoidal current waveform for smooth operation
- Low current ripple for low noise
- Low Cost
- High Efficiency

OPTIONS

ADJUST TRIMPOT

This trimpot adjusts the motor for the smoothest possible low speed operation. Set the motor speed to about ¼ revolutions per second, and then, using a flathead screwdriver turn the trimpot until a distinct null is noted in the motor's vibration. This will result in the most even microstep placement for a given motor and power supply voltage. The trimpot is located on the opposite side of main connector on the driver.



AUTO CURRENT REDUCTION

The R701P reduces motor phase current to 70% of the set value when the motor is holding. To disable this feature, set SW9 "OFF". Choices for hold current are 70% or 100% for the R701P.

OPTION SET SWITCHES

Terminal 11: Current Set (OPTIONAL) - Connect one end of the resistor to this terminal.

Terminal 12: Current Set (OPTIONAL) - Connect the other end of the resistor to this terminal.

This terminal is a filter ground.

Resistor Values to set the Current

DIP switches 1, 2, 3, 4, and 5 must be set to ON if an external current set resistor is used.

OPTION SET SWITCHES



- 1 = CURRENT SET
- 2 = CURRENT SET
- 3 = CURRENT SET
- 4 = CURRENT SET
- 5 = CURRENT SET
- 6 = NOT USED
- 7 = NOT USED
- 8 = NOT USED
- 9 = AUTO STANDBY
- 10 = NEMA 34 & 42 MOTOR



DIMENSIONS

Size: 2.5" x 2.5" x 0.838"

(63.5 mm x 63.5 mm x 21.3 mm)

Weight: 3.6 oz (100 gm)

Mounting: Four #6-32 screws,
1.75" x 2.372" (44.5 mm x 60.2 mm)

Cover: Aluminum, Anodized

Plate: Aluminum, Hard Anodized

Color: Blue exterior, White Text

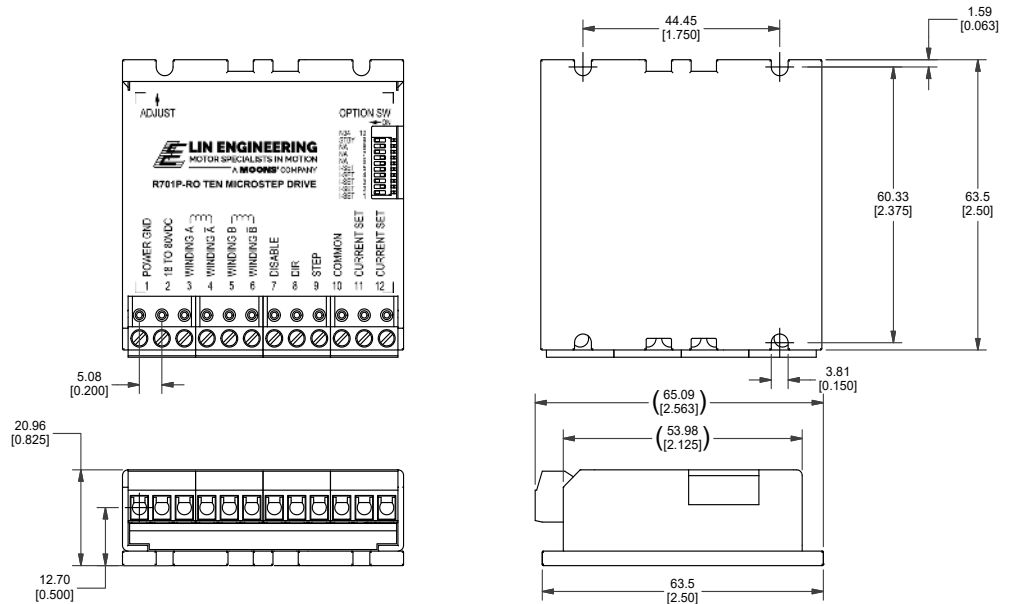

PIN OUTS

Pin #	Color
1	Power Ground
2	+18 to 80 VDC
3	A Phase
4	A Bar Phase
5	B Phase
6	B Bar Phase
7	Disable Input
8	Direction Input
9	Step Input
10	+5 VDC
11	Current Set
12	Current Set

To set the current with the correct resistor, use the following table:

Current (Amps)	Resistance (Ohms)
1	8.2K
2	18K
3	36K
4	62K
5	120K
6	270K

ELECTRICAL SPECIFICATIONS

- Supply Voltage: +18 to 80 VDC
- Peak Current: 0 to 7 Amps
- Auto Current Reduction: 70% of set current, 1 second after last Step Pulse
- Quiescent Current: 15 mAmps or less
- Resolution: 10 microstepping
- Motor Inductance: 1 - 50 mH

OPERATING SPECIFICATIONS

- Step Pulse Time on falling edge (0) (COMMON 3.3V-5V): 0.5 μ S minimum
- Step Pulse Time on rising edge (1) (COMMON 3.3V-5V): 3.0 μ S minimum
- Step Pulse Time on falling edge (0) (GND): 3 μ S minimum
- Step Pulse Time on rising edge (1) (GND): 0.5 μ S minimum
- Direction Setup: 0 μ S minimum
- Operating Temperature: 0° to 70° Celsius
- Humidity Range: 0 to 95% (non-condensing)
- Power Dissipation: 1 to 13 Watts (1 to 7 Amps)

ACCESSORIES

- No accessories are needed for this product.
- Other units needed to run this: Power Supply, Function Generator (or other squarewave signal source), Step Motor, Resistors.

Motion Control, Solved.

MOTOR ENGINEERING & MANUFACTURING



Optimized
For Your
Application



Quick
Prototype
Turnaround



Small Batch
to OEM Volume
Production



US Based
Support &
Manufacturing