

Features

- 5W WPC 1.2 Compliant Wireless Power Transmitter Single Chip Solution for TX-A6
- Excellent EMI performance eliminates need for EMI filters
- 12V Operating Input Voltage
- Closed-Loop Power Transfer Control Between Base Station and Mobile Device
- Demodulates and Decodes WPC-Compliant Message Packets
- 5V Regulated DC/DC Converter
- Integrated RESET Function
- Internal half-bridge power MOSFETs
- Proprietary Back-Channel Communication
- I²C Interface
- Push-Pull GPIO/LED Indicator Outputs
- Over-Temperature Protection
- Optional Buzzer Support
- Foreign Object Detection (FOD)

Applications

- WPC-Compliant Wireless Charging Base Stations

Description

The P9036B is a highly integrated WPC-compliant wireless power transmitter IC for power transmitter WPC design TX-A6. This device operates with a 12Vdc adaptor, and drives an external load directly via an internal half-bridge. It controls the transferred power by changing the switching frequency of the half-bridge inverter from 110 kHz to 205 kHz as specified by the WPC specification for an “A6” transmitter. It contains logic circuits required to demodulate and decode WPC-compliant message packets sent by the mobile device to adjust the transferred power.

The P9036B is an intelligent device, which manages mobile device detection, and selection of one of the three coils of the A6 transmitter coil without user supervision. The A6 configuration allows free mobile device positioning over a wider area than configurations that use a single coil, detecting a mobile device for charging while minimizing idle power. Once the mobile device is detected and authenticated, the P9036B continuously monitors all communications from the mobile device, and adjusts the transmitted power accordingly by varying the switching frequency of the internal half-bridge inverter.

The P9036B can optionally support a proprietary back-channel communication mode, which enables the device to communicate with IDT’s wireless power receiver solutions. This feature enables additional layers of capabilities beyond the standard WPC requirements.

The P9036B includes over-temperature/current protection and WPC compliant Foreign Object Detection (FOD) to protect the base station from overloading in the presence of a metallic foreign object. Additionally, it manages fault conditions associated with power transfer and controls LED outputs to indicate operating status.

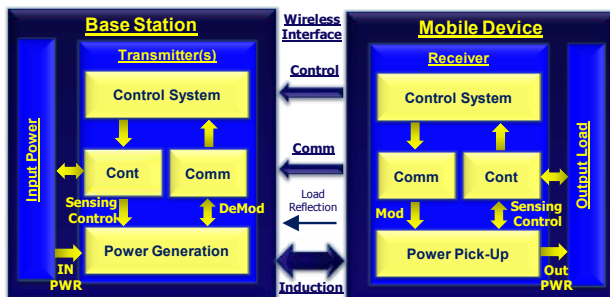

Package: 6x6-48 TQFN

SIMPLIFIED APPLICATION DIAGRAM

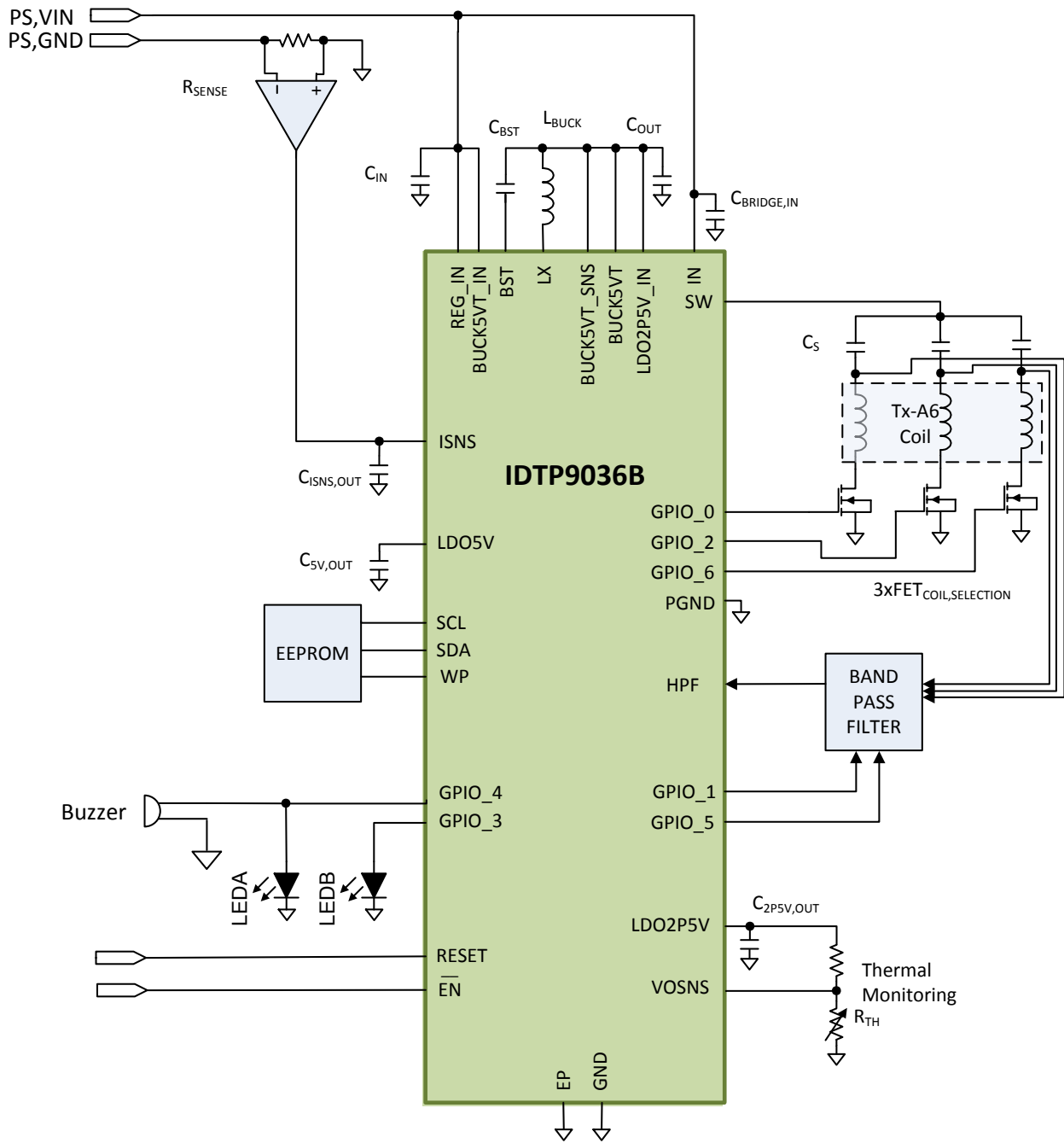

Figure 1. P9036B Simplified Application Schematic

ABSOLUTE MAXIMUM RATINGS

Stresses above the ratings listed below (Table 1 and Table 2) can cause permanent damage to the P9036B. These ratings, which are standard values for IDT commercially rated parts, are stress ratings only. Functional operation of the device at these or any other conditions above those indicated in the operational sections of the specifications is not implied. Exposure to absolute maximum rating conditions for extended periods can affect product reliability. Electrical parameters are guaranteed only over the recommended operating temperature range.

Table 1 Absolute Maximum Ratings Summary. All voltages are referred to GND, unless otherwise noted.

PINS	RATING	UNITS
BUCK5VT_IN, REG_IN, IN, IN1, IN2, SW, SW1, SW2	-0.3 to 24	V
$\overline{\text{EN}}$, LX	-0.3 to VIN+0.3	V
BST	-0.3 to VIN+5	V
LDO2P5V	-0.3 to 2.75	V
AGND, DGND, PGND, PGND1, PGND2, PGND3, GND, REFGND, EP, IC1, IC2, IC5	-0.3 to +0.3	V
BUCK5VT_SNS, BUCK5VT, GPIO0, GPIO1, GPIO2, GPIO3, GPIO4, GPIO5, GPIO6, HPF, ISNS, LDO2P5V_IN, LDO5V, RESET, SCL, SDA, VOSNS	-0.3 to +6.0	V

Table 2 Package Thermal Information

SYMBOL	DESCRIPTION	RATING	UNITS
θ_{JA}	Thermal Resistance Junction to Ambient (NTG48 - TQFN)	30.8	°C/W
θ_{JC}	Thermal Resistance Junction to Case (NTG48 - TQFN)	14.6	°C/W
θ_{JB}^2	Thermal Resistance Junction to Board (NTG48 - TQFN)	0.75	°C/W
T_J	Junction Operating Temperature	-40 to +125	°C
T_A	Ambient Operating Temperature	-40 to +85	°C
T_{STG}	Storage Temperature	-55 to +150	°C
T_{LEAD}	Lead Temperature (soldering, 10s)	+300	°C

Note 1: The maximum power dissipation is $P_{D(MAX)} = (T_{J(MAX)} - T_A) / \theta_{JA}$ where $T_{J(MAX)}$ is 125°C, the maximum junction operating temperature. Exceeding the maximum allowable power dissipation will result in excessive die temperature, and the device will enter thermal shutdown.

Note 2: This thermal rating was calculated on JEDEC 51 standard 4-layer board with dimensions 4" x 4" in still air conditions.

Note 3: Actual thermal resistance is affected by PCB size, solder joint quality, layer count, copper thickness, air flow, altitude, and other unlisted variables.

Note 4: For the NTG48 package, connecting the 4.1 mm X 4.1 mm EP to internal/external ground planes with a 5x5 matrix of PCB plated-through-hole (PTH) vias, from top to bottom sides of the PCB, is recommended for improving the overall thermal performance.

Table 3 ESD Information

TEST MODEL	PINS	RATINGS	UNITS
HBM	All	±2000	V
CDM	All	±500	V

ELECTRICAL CHARACTERISTICS

\overline{EN} = RESET = 0V, REG_IN = BUCK5VT_IN = 12V. T_A = -40 to +85°C, unless otherwise noted. Typical values are at 25°C, unless otherwise noted.

Table 4 Device Characteristics

SYMBOL		DESCRIPTION	CONDITIONS	MIN	TYP	MAX	UNITS
Input Supplies & Switching Frequency							
V_{IN}		Input Supply Operating Voltage Range ¹		11.4	12	12.6	V
I_{IN}^2	I_{IN_A}	Standby Input Current	After power-up sequence complete. Average including pinging		18		mA
	I_{IN_S}	Sleep Mode Input Current	\overline{EN} = 5V to V_{IN}		460	600	μA
F_{SW_LOW}		Switching Frequency at SW	WPC-compliant Operating Range	110			kHz
F_{SW_HIGH}						205	kHz
UVLO & Current Limit							
V_{IN_UVLO}	Under-Voltage Protection Trip Point	V_{IN} rising				10.3	V
		V_{IN} falling		9.0			
		Hysteresis			625		mV
I_{IN_OCP}	Over-Current Protection Trip Point	V_{IN} = 12.6V, cycle-by-cycle protection.		5.2		6.5	A
DC-DC Converter (For Biasing Internal Circuitry Only)³							
$V_{BUCK5VT_IN}$		Input Voltage Range ¹		11.4		12.6	V
$V_{BUCK5VT}$		Output Voltage	External I_{Load} = 8mA	4.5	5	5.5	V
I_{OUT}^5		External Load				8	mA
F_{SW}		Switching Frequency at LX			3		MHz
Low Drop Out Regulators (For Biasing Internal Circuitry Only)³							
LDO2P5V³							
$V_{LDO2P5V_IN}$		Input Voltage Range	Supplied from BUCK5VT		5		V
$V_{LDO2P5V}$		Output Voltage	I_{Load} = 2mA		2.5		V
I_{OUT}		External Load				8	mA
LDO5V³							
V_{REG_IN}		Input Voltage Range	See Note 1.	11.4		12.6	V
V_{LDO5V}		Output Voltage	I_{Load} = 2mA		5		V
Thermal Shutdown							
T_{SD}	Thermal Shutdown	Temperature Rising Threshold			140		°C
		Temperature Falling Threshold			110		

ELECTRICAL CHARACTERISTICS

\overline{EN} = RESET = 0V, REG_IN = BUCK5VT_IN = 12V. T_A = -40 to +85°C, unless otherwise noted. Typical values are at 25°C, unless otherwise noted.

Table 4 Device Characteristics, Continued

SYMBOL	DESCRIPTION	CONDITIONS	MIN	TYP	MAX	UNITS
EN						
V_{IH}				900		mV
V_{IL}				550		mV
I_{EN}	\overline{EN} input current	$V_{EN} = 5V$		7.5		μA
		$V_{EN} = V_{IN} = 12.6V$		35		μA
General Purpose Inputs / Outputs (GPIO)						
V_{IH}	Input Threshold High		3.5			V
V_{IL}	Input Threshold Low				1.5	V
I_{LKG}	Input Leakage		-1		+1	μA
V_{OH}	Output Logic High	$I_{OH} = -8mA$	4			V
V_{OL}	Output Logic Low	$I_{OL} = 8mA$			0.5	V
I_{OH}	Output Current High		-8			mA
I_{OL}	Output Current Low				8	mA
RESET						
V_{IH}	Input Threshold High		3.5			V
V_{IL}	Input Threshold Low				1.5	V
I_{LKG}	Input Leakage		-1		+1	μA
SCL, SDA (I²C Interface)						
f_{SCL}	Clock Frequency	EEPROM loading, Step 1, P9036B as Master		100		kHz
f_{SCL}	Clock Frequency	EEPROM loading, Step 2, P9036B as Master		300		kHz
f_{SCL}	Clock Frequency	P9036B as Slave	0		400	kHz
$t_{HD,STA}$	Hold Time (Repeated) for START Condition		0.6			μs
$t_{HD,DAT}$	Data Hold Time	I ² C-bus devices	10			ns
t_{LOW}	Clock Low Period		1.3			μs
t_{HIGH}	Clock High Period		0.6			μs
$t_{SU,STA}$	Set-up Time for Repeated START Condition		100			ns

ELECTRICAL CHARACTERISTICS

\overline{EN} = RESET = 0V, REG_IN = BUCK5VT_IN = 12V. T_A = -40 to +85°C, unless otherwise noted. Typical values are at 25°C, unless otherwise noted.

Table 4 Device Characteristics, Continued

SYMBOL	DESCRIPTION	CONDITIONS	MIN	TYP	MAX	UNITS
t_{BUF}	Bus Free Time Between STOP and START Condition		1.3			μ s
C_B	Capacitive Load for Each Bus Line				100	pF
C_{BIN}	SCL, SDA Input Capacitance ⁵			5		pF
V_{IL}	Input Threshold Low	When powered by device 5V			1.5	V
V_{IH}	Input Threshold High		3.5			V
I_{LKG}	Leakage Current		-1.0		1.0	μ A
V_{OL}	Output Logic Low (SDA)	$I_{PD} = 2mA$			0.5	V
Analog-to-Digital Converter						
N	ADC Conversion Resolution			12		Bit
f_{SAMPLE}	Sampling Rate			62.5		kSPS
Channel	Number of Channels at ADC MUX input			8		
ADC _{CLK}	ADC Clock Frequency			1		MHz
V_{IN_FS}	Full-Scale Input Voltage			2.39		V
Microcontroller						
F_{CLOCK}	Clock Frequency			40		MHz
V_{MCU}	MCU Supply Voltage from internal 2.5V LDO			2.5		V

Note 1: BUCK5VT_IN, REG_IN. These pins must be connected together at all times.

Note 2: This current is the sum of the input currents for REG_IN and BUCK5VT_IN.

Note 3: DC-DC BUCK5VT, LDO2P5V and LDO5V are intended only as internal device supplies and must not be loaded externally except for the EEPROM, thermistor, LED, buzzer and pull-up resistor loads (up to an absolute maximum of 8mA), as recommended in the WPC "Qi" Compliance Schematic and the WPC "Qi" Compliance Bill of Materials. If any of these outputs is used to power external loads, the performance of the P9036B is not guaranteed.

Note 4: Any of the GPIO pins is capable of sourcing 8mA, but if more than one is sourcing current, the total current must not exceed 8mA.

Note 5: The 2.5V LDO is powered by the 5V DC/DC converter, so the LDO's output current must be counted in the output current budget of the DC/DC converter.

PIN CONFIGURATION

TQFN-48L

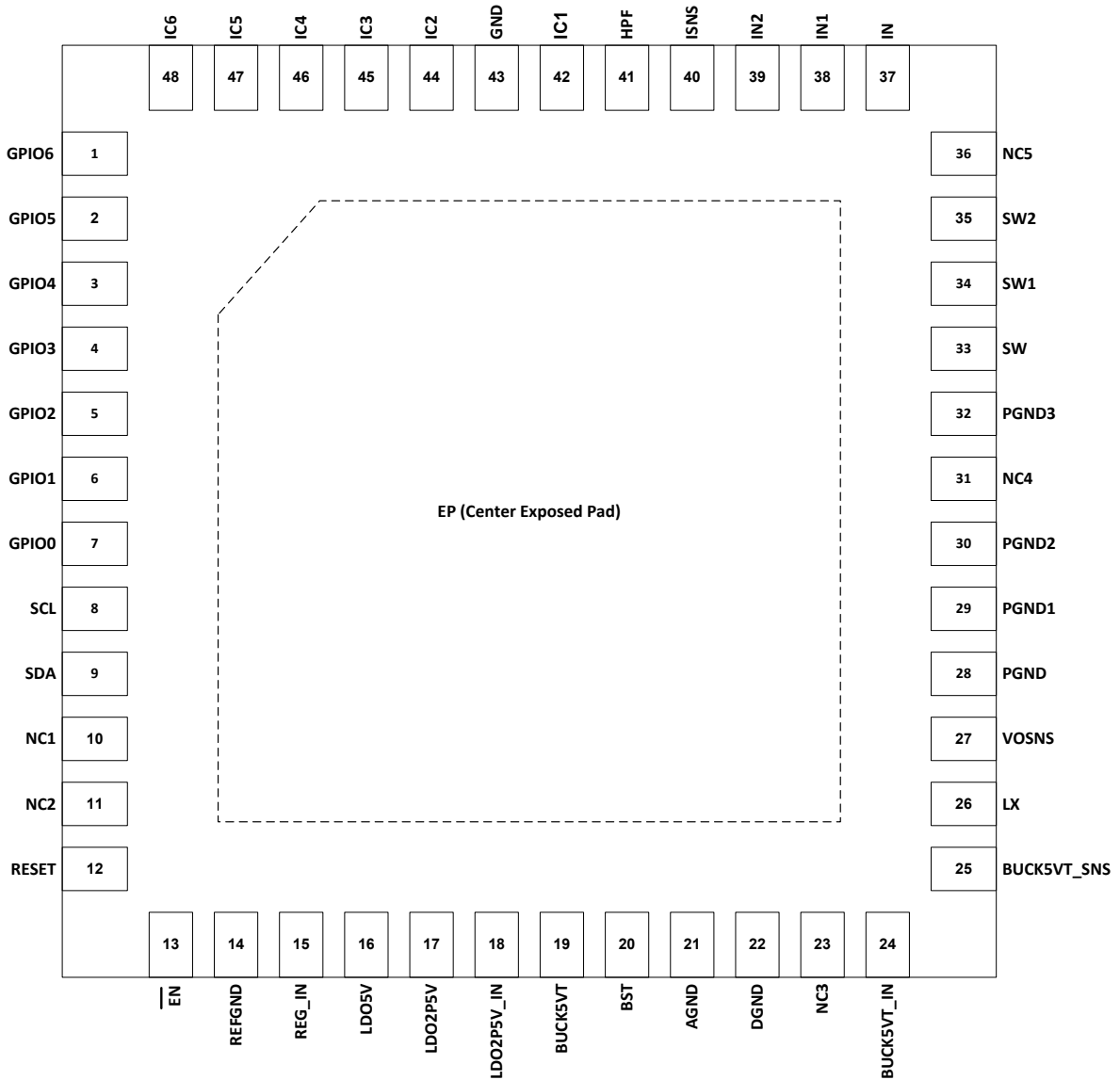

Figure 2 P9036B Pin Configuration (NTG48 TQFN-48L 6.0 mm x 6.0 mm x 0.75 mm, 0.4mm pitch)

PIN DESCRIPTION

Table 5 P9036B NTG48 Package Pin Functions by Pin Number

1	GPIO6	I/O	General purpose input/output 6.
2	GPIO5	I/O	General purpose input/output 5.
3	GPIO4	I/O	General purpose input/output 4.
4	GPIO3	I/O	General purpose input/output 3.
5	GPIO2	I/O	General purpose input/output 2.
6	GPIO1	I/O	General purpose input/output 1.
7	GPIO0	I/O	General purpose input/output 0.
8	SCL	I/O	I ² C clock.
9	SDA	I/O	I ² C data.
10	NC1	-	Internally connected. Must be connected to GND.
11	NC2	-	Internally connected. Must be left unconnected.
12	RESET	I	Active-high chip reset pin. A 47k Ω resistor must be connected between this pin and GND.
13	$\overline{\text{EN}}$	I	Active-low enable pin. Device is suspended and placed in low current (sleep) mode when pulled high. Tie to GND for stand-alone operation.
14	REFGND	-	Signal ground connection. Must be connected to AGND.
15	REG_IN ¹	I	LDO5V power supply input. As a minimum, a 1 μ F ceramic capacitor must be connected between this pin and PGND. This pin must be connected to pin 24.
16	LDO5V ²	O	5V LDO output. As a minimum, a 1 μ F ceramic capacitor must be connected between this pin and PGND.
17	LDO2P5V ²	O	2.5V LDO output. As a minimum, a 1 μ F ceramic capacitor must be connected between this pin and PGND.
18	LDO2P5V_IN	I	2.5V LDO input. The LDO2P5V_IN input must be connected to BUCK5VT. As a minimum, a 0.1 μ F ceramic capacitor must be connected between this pin and GND.
19	BUCK5VT ²	I	Power and digital supply input to internal circuitry.

Table 5 P9036B NTG48 Package Pin Functions by Pin Number

PIN	NAME	TYPE	DESCRIPTION
20	BST	I	Bootstrap pin for BUCK converter top switch gate drive supply.
21	AGND	-	Analog ground connection. Connect to signal ground. Must be connected to REFGND.
22	DGND	-	Digital ground connection. Must be connected to GND.
23	NC3	-	Internally connected. Must be left unconnected.
24	BUCK5VT_IN ¹	I	Buck converter power supply input. As a minimum, a 0.1μF in parallel with a 1μF ceramic capacitor must be connected between this pin and PGND. This pin must be connected to pin 15.
25	BUCK5VT_SNS	I	Buck regulator feedback. Connect to the high side of the buck converter output capacitor.
26	LX	O	Switch Node of BUCK converter. Connects to one of the inductor's terminals.
27	VOSNS	I	Voltage sense input. This pin can be used to sense voltages such as thermistors, GPIOs, Input voltages. See the Electrical Characteristics Table (V_{IN_FS}) for input voltage limits.
28	PGND	-	Power ground.
29	PGND1	-	Power ground.
30	PGND2	-	Power ground.
31	NC4	-	Internally connected. Must be left unconnected.
32	PGND3	-	Power ground.
33	SW	O	Internal – monolithic – power MOSFET, half bridge switching node. These pins drive the transmitter coil.
34	SW1	O	
35	SW2	O	
36	NC5	-	Internally connected. Must be left unconnected.
37	IN	I	Internal – monolithic – power MOSFET, half bridge power supply input pins.
38	IN1	I	
39	IN2	I	
40	ISNS	O	ISNS output signal. Current used by the transmitter as measured at the input voltage. Attach a 22nF ceramic capacitor to this pin for filtering purposes.

Table 5 P9036B NTG48 Package Pin Functions by Pin Number

PIN	NAME	TYPE	DESCRIPTION
41	HPF	I	High pass filter input. This pin is used to read the communication from the receiver.
42	IC1		Reserved for special designs. Must be connected to GND.
43	GND	-	Ground.
44	IC2		Reserved for special designs. Must be connected to GND.
45	IC3		Reserved for special designs. Must be left unconnected.
46	IC4		Reserved for special designs. Must be left unconnected.
47	IC5		Reserved for special designs. Must be connected to GND.
48	IC6		Reserved for special designs. Must be left unconnected.
49	EP (Center Exposed Pad)	Thermal	EP, Center Exposed Pad, is on the bottom of the package and must be electrically tied to GND. For good thermal performance, solder to a large copper pad embedded with a pattern of plated through-hole vias. The die is not electrically bonded to the EP, and the EP must not be used as a current-carrying electrical connection.

Note 1: REG_IN, BUCK5VT_IN. These pins must be connected together at all times.

Note 2: DC-DC BUCK5VT, LDO2P5V and LDO5V are intended only as internal device supplies and must not be loaded externally except for the EEPROM, thermistor, LED, buzzer and pull-up resistor loads (up to an absolute maximum of 8mA), as recommended in the WPC “Qi” Compliance Schematic and the WPC “Qi” Compliance Bill of Materials.

TYPICAL PERFORMANCE CHARACTERISTICS

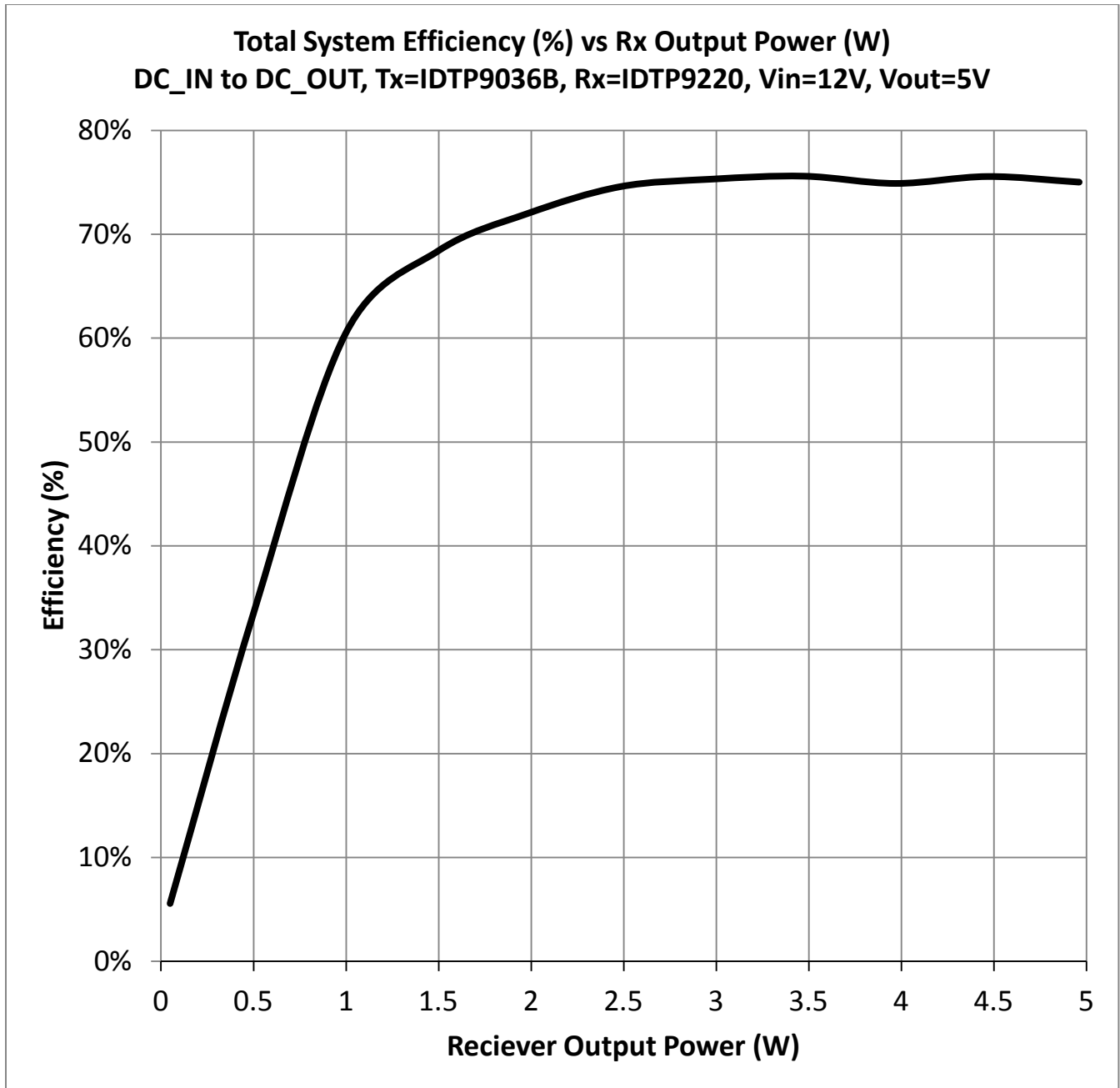

Figure 3. Efficiency vs. RX Output Power

BLOCK DIAGRAM

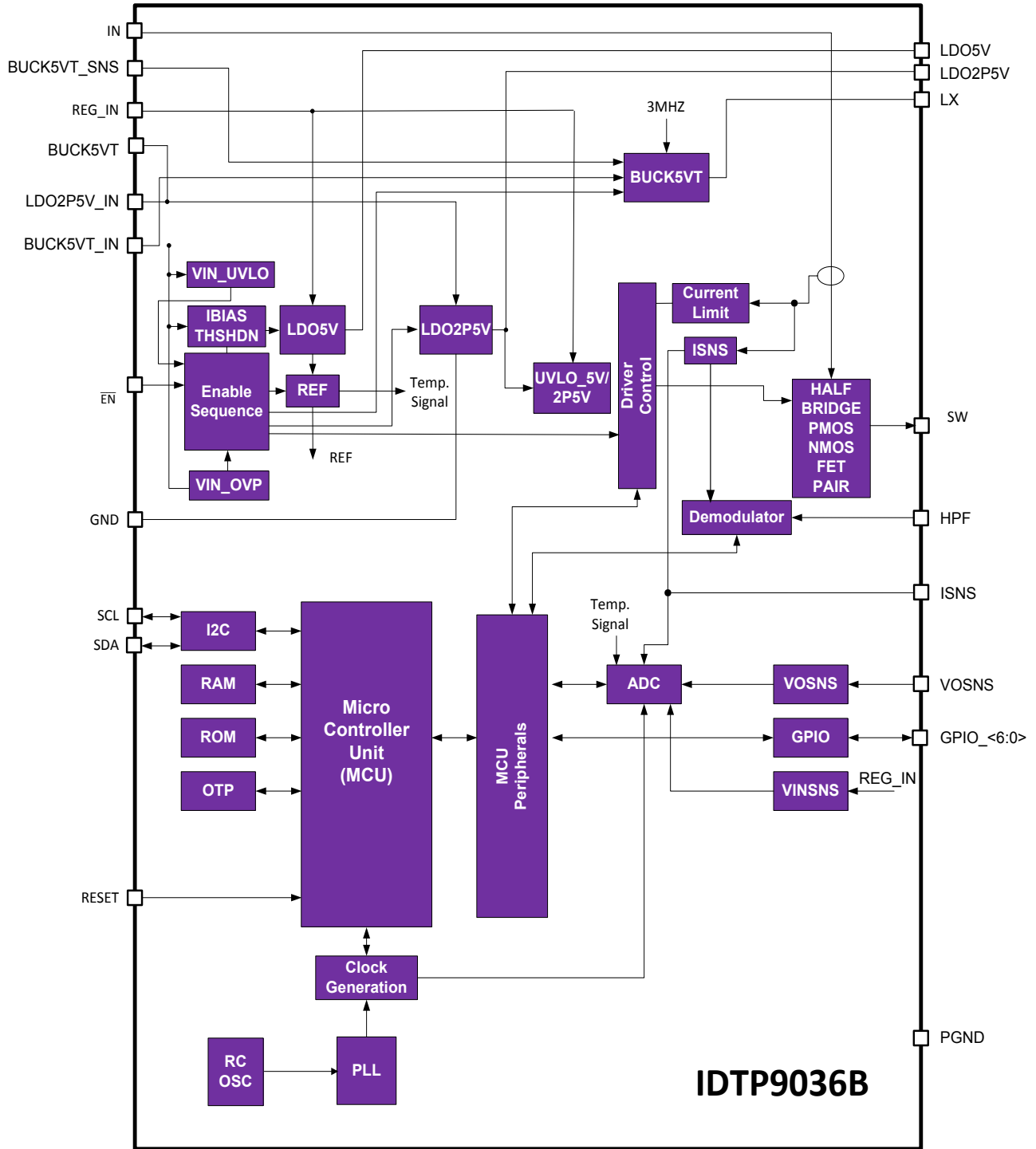

Figure 4. P9036B Internal Functional Block Diagram

THEORY OF OPERATION

The P9036B is a highly-integrated WPC¹ (Wireless Power Consortium)-compliant wireless power charging IC solution for the transmitter base station. It can deliver 5W in WPC “Qi” mode using near-field magnetic induction as a means to transfer energy

OVERVIEW

Figure 1 shows the block diagram of the P9036B. When the VIN_UVLO block detects that the voltage at REG_IN and BUCK5VT_IN (connected together externally) is above the Vin_rising UVLO threshold and EN is at a logic LOW, the Enable Sequence circuitry activates the voltage reference, the 5V and 2.5V LDOs, and the 5V buck switching regulator.

The voltages at the outputs of the LDOs and the buck regulator are monitored to ensure that they remain in regulation, and the adaptor voltage, coil current, and internal temperature are monitored.

The digital block and the MCU drive an internal half bridge inverter. This inverter powers the transmitter (Tx) coil through the SW pins. The Tx and receiver (Rx) act as a loosely coupled, air core transformer. The Tx coil generates a magnetic field that supplies energy to the Rx coil. The Rx uses that field to generate a DC output voltage that is applied to the load.

Communication packets from the receiver in the mobile device are detected and filtered by an external operational amplifier and passive filter, then provided to the HPF pin to be further processed by the Demodulator and converted to digital signals that can be read by the MCU.

Several internal voltages are digitized by the ADC and supplied to the MCU for system control and algorithm – related purposes. Two GPIO ports are available to the system designer for driving LEDs and a buzzer. The clock for the MCU and other circuitry is generated by an internal RC oscillator. I²C SDA and SCL pins permit communication with an external device or host.

Note 1 - Refer to the WPC specification at <http://www.wirelesspowerconsortium.com/> for the most current information

UNDER VOLTAGE LOCKOUT (UVLO)

The P9036B has a built-in UVLO circuit that monitors the input voltage and enables normal operation, as shown in the following figure:

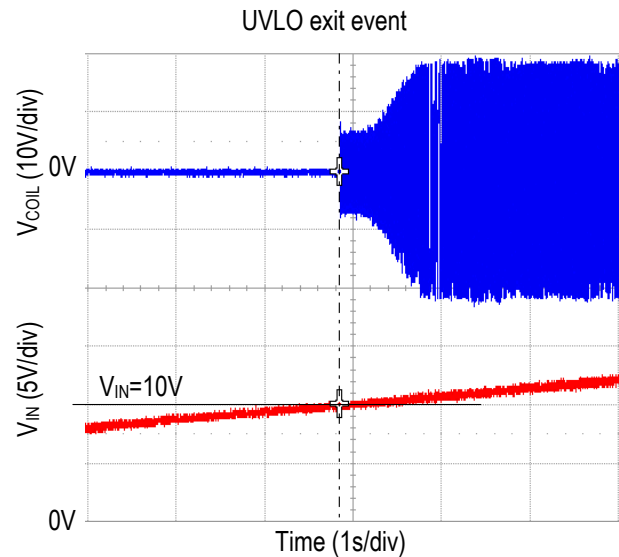

Figure 4 V_{IN} versus UVLO threshold with /EN low.

OVER-TEMPERATURE PROTECTION

The internal temperature of the P9036B is monitored. The part shuts down if the temperature exceeds 140°C (typ) and reactivates when the temperature falls below 110°C (typ).

INTERNAL DRIVERS and INVERTER

The internal gate driver circuitry drives the transmitter coil which delivers energy to the receiver (Rx) coil. The internal FETs are configured as a power inverter that switches the top sides of the resonant circuits between the VIN supply voltage and ground at a rate set by the MCU control algorithm.

DEMODULATOR

Power is transferred from the transmitter to the receiver through the coupling of their respective coils: a loosely-coupled transformer. The amount of power transferred is determined by the transmitter’s switching frequency

(110kHz-205kHz, by WPC¹), and is controlled by the receiver through instructions the receiver sends back through the same coils to the transmitter to increase or decrease power, end power transfer, or another WPC command. The instructions take the form of data packets which the receiver modulates on the carrier. The modulation is detected and then coupled through a series of filters connected to the P9036B's Demodulator and then fed to the HPF pin. Recovering the data packets is the function of the Demodulator. Decoding and executing the packets is one of the functions of the MCU.

MICROCONTROLLER UNIT (MCU)

The P9036B's MCU processes the algorithm, commands, and data that control the power transferred to the receiver. The MCU is provided with RAM and ROM, and parametric trim and operational modes are set at the factory through the One-Time Programming (OTP) block, read by the MCU at power-up. Communication with external memory is performed through I²C via the SCL and SDA pins.

APPLICATIONS INFORMATION

The recommended applications schematic diagram is shown in Figure 7. The P9036B operates from a 12V_{DC} (±5%) input. The switching frequency varies from 110kHz to 205kHz. The power transfer is controlled via changes in switching frequency. The base or TX-side has three series-resonance circuits made of a WPC Type-A6 triple coil and three capacitors. The resonant circuits are driven by an internal half-bridge inverter, as shown in Figure 5. Only the resonant circuit that is aligned with the receiver coil is activated. The selection is made by voltage levels from GPIO0, GPIO2 and GPIO6, each of which drives one of three external selection FETs directly which activates the respective coil.

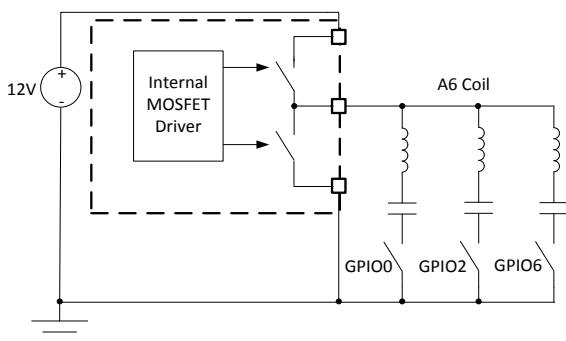

Figure 5 Half Bridge Inverter TX Coil Driver.

EXTERNAL CHIP RESET and EN

The P9036B can be externally reset by pulling the RESET pin to a logic high above the V_{IH} level.

The RESET pin is a dedicated high-impedance active-high digital input, and its effect is similar to the power-up reset function. Because of the internal low-voltage monitoring scheme, the use of the external RESET pin is not mandatory. A manual external reset scheme can be added by connecting 5V to the RESET pin through a simple switch. When RESET is HIGH, the microcontroller's registers are set to the default configuration. When the RESET pin is released to a LOW, the microcontroller starts executing the code from the EEPROM.

If the particular application requires the P9036B to be disabled, this can be accomplished with the EN pin. When the EN pin is pulled high, the device is suspended and placed in low current (sleep) mode. If pulled low, the device is active.

The current into EN is approximately

$$I_{EN} = \frac{V_{EN} - 2V}{300k\Omega}$$

for input voltages between V_{IN} and +2V, and close to zero if V(EN) is less than 2V.

SYSTEM FEEDBACK CONTROL (WPC)

The P9036B contains logic to demodulate and decode error packets sent by the mobile device (Rx-side), and adjusts power transfer accordingly. The P9036B varies the switching frequency of the internal half bridge inverter between 110kHz to 205 kHz to adjust power transfer. The mobile device controls the amount of power transferred via a communication link that exists from the mobile device to the base station. The mobile device (any WPC-compliant receiver) communicates with the P9036B via Communication Packets. Each packet has the following format:

Table 6 – Data Packet Format.

Preamble	Header	Message	Checksum
----------	--------	---------	----------

The overall system behavior between the transmitter and receiver follows the state machine diagram below:

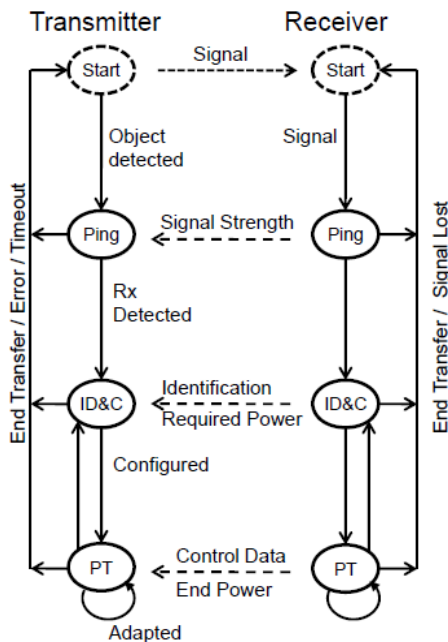

Figure 6 System State Machine Diagram

The P9036B performs four phases: Selection, Ping, Identification & Configuration, and Power Transfer.

START (SELECTION) PHASE

In this phase, the P9036B operates in a low power mode to determine if a potential receiver has been placed on the coil surface prior to the PING state. At regular intervals, the P9036B applies a brief AC signal sequentially to each one of the coils of the triple A6 coil and listens for a response. When a response is found, the P9036B keeps that coil selected for all subsequent operations.

PING PHASE

In this phase, the P9036B applies a power signal at 175 kHz with a fixed 50% duty cycle and attempts to establish a communication link with a mobile device.

Required packet(s) in PING:

1. Signal Strength Packet (0x01)

The mobile device must send a Signal Strength Packet within a time period specified by the WPC, otherwise the power signal is terminated and the process repeats.

If the P9036B does not detect the start bit of the header byte of the Signal Strength Packet during the Ping Phase, it removes the Power Signal after a delay. If a Signal Strength Packet is received, the P9036B goes to the Identification and Configuration Phase.

IDENTIFICATION AND CONFIGURATION (ID & Config)

In this phase, the P9036B tries to identify the mobile device and collects configuration information.

Required packet(s) in ID & Config:

1. Identification Packet (0x71)
2. Extended Identification Packet (0x81)*
3. Configuration Packet (0x51)

* If Ext bit of 0x71 packet is set to 1.

Also, the P9036B must correctly receive the following sequence of packets without changing the operating point (175 kHz @ 50% duty cycle):

1. Identification Packet (0x71)
2. Extended Identification (0x81)
3. Up to 7 optional configuration packets from the following set: Power Control Hold-Off Packet (0x06), Proprietary Packet (0x18 – 0xF2), Reserved Packet
4. Configuration Packet (0x51)

If the P9036B detects a valid configuration sequence, with the proper timing, then it will move to the Power Transfer phase. Otherwise, it will terminate the power signal and revert to the Selection phase.

POWER TRANSFER PHASE

In this phase, the P9036B adapts the power transfer to the receiver based on control data it receives as contained in the Control Error Packets.

Required packet(s) in Power Transfer:

1. Control Error Packet (0x03)
2. Rectified Power Packet (0x04)

For this purpose, the P9036B may receive zero or more of the following packets:

1. Control Error Packet (0x03)
2. Rectified Power Packet (0x04)
3. Charge Status Packet (0x05)
4. End Power Transfer Packet (0x02)
5. Any Proprietary Packet
6. Any reserved Packets

If the P9036B receives a packet that does not comply with the sequence, or if the time limits for receiving the

Product Datasheet

expected packets are exceeded, then P9036B will terminate the power signal and revert to the Selection phase.

EXTERNAL OVER TEMPERATURE PROTECTION

At all times the P9036B periodically checks the DC voltage from the external thermistor circuit. If the external temperature limit is exceeded, then the P9036B immediately terminates the power transfer and signals an error condition on the LED outputs. It remains in this state until the over temperature condition is corrected.

FOREIGN OBJECT DETECTION (FOD)

The P9036B supports foreign object detection in accordance with WPC specifications. Periodically the Receiver reports to the P9036B the amount of received power by sending a Received Power packet. The P9036B compares the amount of power transmitted with the report amount of received power. If too much power is being lost then the presence of a foreign object is assumed. In that case, the P9036B terminates the power transfer and signals an error condition on the LED outputs.

The calibration of the FOD is primarily set in the P9036B firmware. However, some adjustment of the FOD is possible by changing external resistor values that change the DC voltage seen by GPIO4. There are three cases for

1. Pull down resistor only is no adjustment to the internal firmware's FOD setting.
2. Pull up resistor only disables the FOD function
3. A combination of pullup/pulldown resistors creates a DC voltage which determines an amount of offset that will be added or subtracted from the internal firmware settings. If the DC voltage is approximately 1.20V then the adjustment will be zero. If the voltage is greater than 1.2V then the adjustment will increase the allowance for foreign objects up to approximately 300mW additional loss. If the voltage is less than 1.2V then the adjustment will decrease the allowance for foreign objects up to approximately 300mW less loss. This adjustment is proportional throughout a voltage range between approximately 50mV to 2.35V

APPLICATIONS INFORMATION

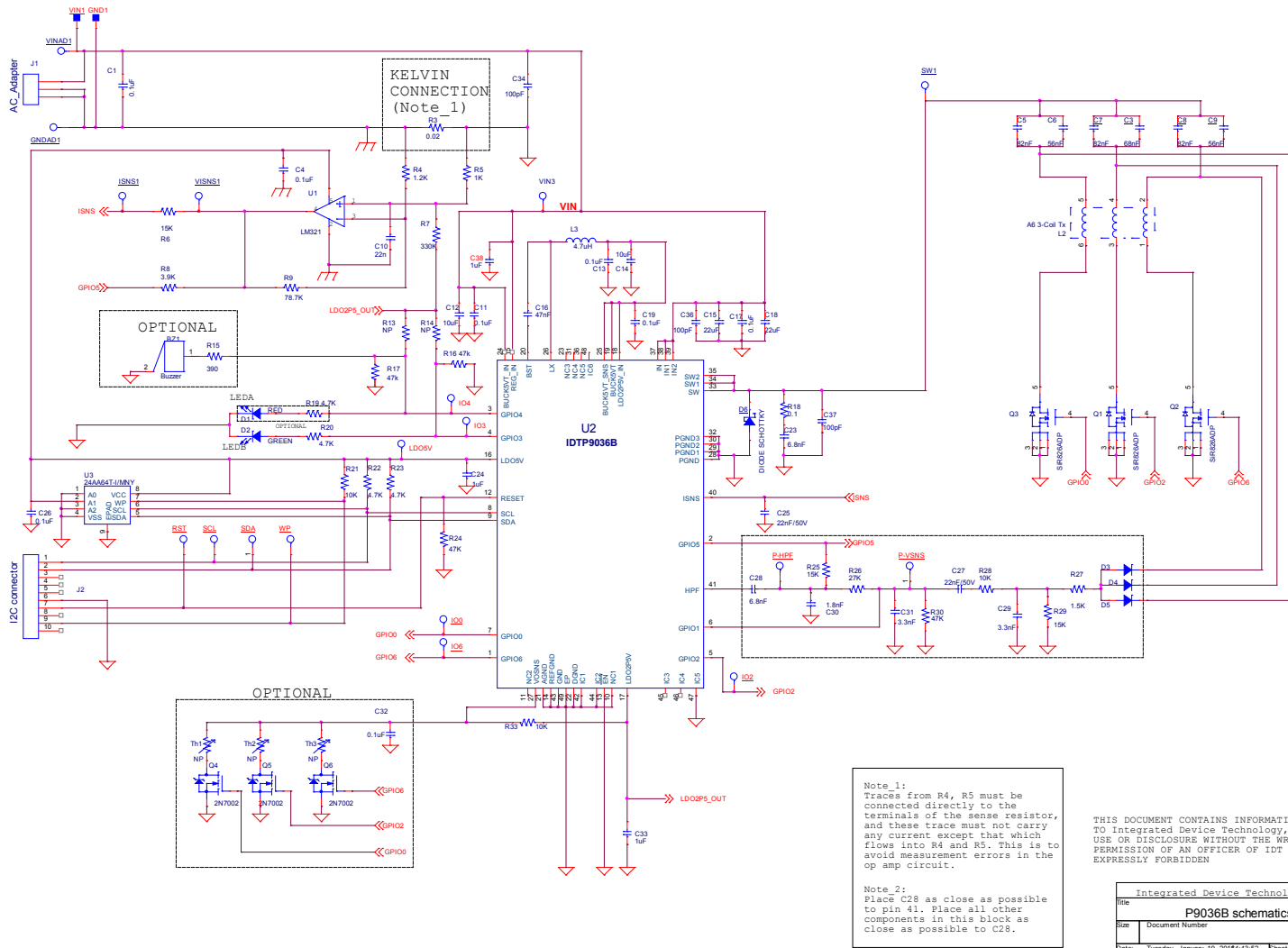

Note_1:
Traces from R4, R5 must be connected directly to the terminals of the sense resistor, and these trace must not carry any current except that which flows into R4 and R5. This is to avoid measurement errors in the op amp circuit.

Note_2:
Place C28 as close as possible to pin 41. Place all other components in this block as close as possible to C28.

THIS DOCUMENT CONTAINS INFORMATION PROPRIETARY TO Integrated Device Technology, Inc. (IDT). USE OR DISCLOSURE WITHOUT THE WRITTEN PERMISSION OF AN OFFICER OF IDT IS EXPRESSLY FORBIDDEN

Integrated Device Technology, Inc.		
Title P9036B schematics		
Rev	Document Number	Rev
Date: Tuesday, January 19, 2016 4:52	Sheet	1 of 1

Figure 7 P9036B Schematic

Table 7 P9036B Bill Of Materials

Item	Quantity	Reference	Part	PCB Footprint	Description	Part Number	Manufacturer
1	1	BZ1	Buzzer	buzz_ps1240	BUZZER PIEZO 4KHZ 12.2MM PC MNT	P51240P02CT3	TDK Corporation
2	2	C1,C17	0.1uF	402	CAP CER 0.1UF 50V 10% X7R 0402	C1005X7R1H104K	
3	1	C3	68nF	1206	CAP CER 0.068UF 100V NPO 1206	C3216COG2A683K160AC	TDK Corporation
4	1	C4	0.1uF	402	CAP CER 0.1UF 50V 10% X7R 0402	C1005X7R1H104K	TDK
5	3	C5,C7,C8	82nF	1206	CAP CER 0.082UF 100V NPO 1812	C1812C823J1GACTU	Murata
6	2	C6,C9	56nF	1206	CAP CER 0.056UF 100V NPO 1812	C1812C563J1GACTU	Murata
7	1	C10	22n	402	CAP CER 2200PF 50V 10% X7R 0402	C1005X7R1E222K	TDK
8	5	C11,C13,C19,C26,C32	0.1uF	603	CAP CER 0.1UF 50V 10% X7R 0603	GRM188R71H104KA93D	Murata
9	2	C12,C14	10uF	805	CAP CER 10UF 25V 20% X5R 0805	C2012X5R1E106M	TDK
10	2	C15,C18	22uF	1206	CAP CER 22UF 25V 10% X5R 1206	GRM31CR61E226KE15L	Murata
11	1	C16	47nF	603	CAP CER 0.047UF 16V 10% X7R 0603	GRM188R71C473KA01D	Murata
12	1	C23	6.8nF	402	CAP CER 6800PF 50V X7R 0402	C1005X7R1H682K050BA	TDK
13	3	C24,C33,C38	1uF	603	CAP CER 1UF 25V 10% X7R 0603	C1608X7R1E105K	TDK
14	2	C25,C27	22nF/50V	603	CAP CER 0.022UF 50V 10% X7R 0603	C1608X7R1H223K	TDK
15	1	C28	6.8nF	402	CAP CER 6800PF 50V 10% X7R 0402	C1005X7R1H682K	TDK Corporation
16	1	C29	3.3nF	603	CAP CER 3300PF 100V 10% X7R 0603	C1608X7R2A332K	TDK
17	1	C30	1.8nF	402	CAP CER 1800PF 50V 10% X7R 0402	04025C182KAT2A	AVX
18	1	C31	3.3nF	402	CAP CER 3300PF 50V 10% X7R 0402	C1005X7R1H332K	TDK Corporation
19	2	C34,C36	100pF	603	CAP CER 100PF 50V 10% X7R 0603	C0603C101K5RACTU	Kemet
20	1	C37	100pF	603	CAP CER 100PF 50V X7R 0603	C0603C101K5RACTU	Kemet
21	1	D1	RED	0603_DIODE	LED RED DIFFUSED 0603 SMD	L29K-G1J2-1-0-2-R18-Z	OSRAM
22	1	D2	GREEN	0603_DIODE	LED GREEN DIFFUSED 0603 SMD	LG L29K-G2J1-24-Z	OSRAM
23	3	D3,D4,D5	Diode	SOD123	DIODE GEN PURP 200V 200MA SOD123	BAV21W-7-F	Diodes Incorporated
24	1	D6	DIODE SCHOTTKY	SOD123FL	DIODE SCHOTTKY 200V 2A SOD123FL	MBR2H2005FT1G	ON Semi
25	18	VISN51,VINAD1,SW1,ISNS1,GNDAD1,I02,VIN3,I03,I04,LDO5V,I06,WP,SDA,SCL,RST,P-VSNS,P-HPF,I00	NP	TP30	TEST POINT 30MIL THROUGH HOLE		
26	2	VIN1,GND1	VC6	SMD_5015	PC TEST POINT MINIATURE SMT	5015	Keystone Electronics
27	1	J1	AC Adapter	CONN_POWER JACKS_5MM	CONN PWR JACK 2.1X5.5MM HIGH CUR	PJ-002AH	CUI INC
28	1	J2	I2C connector	LOPRO8PIN011NREVB	CONN HEADER LOPRO STR 10POS GOLD	5103308-1	TE
29	1	L2	A6 3-Coil Tx	3coil_a6_standard	TX-A6 COIL	Y31-60050F	
30	1	L3	4.7uH	805	FIXED IND 4.7UH 600MA 400 MOHM	MLP2012V4R7MT0S1	TDK Corporation
31	3	Q1,Q2,Q3	SIR826ADP	SOIC8LD_PWRPAK_FET	MOSFET N-CH 80V 60A PPAK SO-8	SIR826ADP	Vishay
32	3	Q4,Q5,Q6	2N7002	SOT23_3	MOSFET N-CH 60V 310MA SOT323	2N7002WV1G	ON Semi
33	1	R3	0.02	805	RES SMD 0.02 OHM 1% 1/8W 0805	WSL0805R0200FEA	Vishay
34	1	R4	1.2K	402	RES 1.2K OHM 1/10W 1% 0402 SMD	ERJ-2RKF1201X	Panasonic
35	1	R5	1K	402	RES SMD 1K OHM 1% 1/10W 0402	ERJ-2RKF1001X	Panasonic
36	1	R6	15K	402	RES SMD 15K OHM 1% 1/10W 0402	ERJ-2RKF1502X	Panasonic
37	1	R7	330K	402	RES 330K OHM 1/16W 5% 0402 SMD	RCO402JR-07330KL	Yageo
38	1	R8	3.9K	402	RES 3.9K OHM 1/10W 5% 0402 SMD	ERJ-2GEJ392X	Panasonic
39	1	R9	78.7K	402	RES SMD 78.7K OHM 1% 1/10W 0402	ERJ-2RKF7872X	Panasonic
40	2	R13,R14	NP	402		NP	
41	1	R15	390	402	RES SMD 390 OHM 5% 1/10W 0402	ERJ-2GEJ391X	Panasonic
42	3	R16,R17,R30	47K	402	RES SMD 47K OHM 5% 1/10W 0402	ERJ-2GEJ473X	Panasonic
43	1	R18	0.1	402	RES SMD 0.1 OHM 1% 1/10W 0402	RUT1005FR100CS	Panasonic
44	4	R19,R20,R22,R23	4.7K	402	RES SMD 4.7K OHM 5% 1/10W 0402	ERJ-2GEJ472X	Panasonic
45	1	R21	10K	402	RES SMD 10K OHM 5% 1/10W 0402	ERJ-2GEJ103X	Panasonic
46	1	R24	47K	402	RES 47K OHM 1/10W 5% 0402 SMD	ERJ-2GEJ473X	Panasonic
47	1	R25	15K	402	RES SMD 15K OHM 5% 1/10W 0402	ERJ-2GEJ153X	Panasonic
48	1	R26	27K	402	RES SMD 27K OHM 5% 1/10W 0402	ERJ-2GEJ273X	Panasonic
49	1	R27	1.5K	603	RES SMD 1.5K OHM 5% 1/10W 0603	ERJ-3GEYJ152V	Panasonic
50	1	R28	10K	603	RES SMD 10K OHM 1% 1/10W 0603	ERJ-3EKF1002V	Panasonic
51	1	R29	15K	603	RES SMD 15K OHM 5% 1/10W 0603	ERJ-3GEYJ153V	Panasonic
52	1	R33	10K	402	RES SMD 10K OHM 1% 1/10W 0402	ERJ-2RKF1002X	Panasonic
53	3	Th1,Th2,Th3	NP	NTC1	THERMISTOR NTC K 5% RADIAL	NTCLE203E3103JB0	Vishay
54	1	U1	LM321	SOT23-5	IC OPAMP GP 1MHZ SOT23-5	LM321MFX	TI
55	1	U2	IDTP9036B	NTG_48LD_6X6MM_OP4PITCH	12V Wireless Power Transmitter IC for TX-A6	P9036B	IDT
56	1	U3	24AA64T-I/MNY	DFN8	IC EEPROM 64KBIT 400KHZ 8TDFN	24AA64T-I/MNY	Microchip Technology

Note 1: COG/NPO-type ceramic capacitors are recommended for use as the resonance capacitors (C2 through C7). COG/NPO values stay relatively constant with voltage while X7R and X5R ceramic capacitor values de-rate from 40% to over 80%.

External Components

The P9036B requires a minimum number of external components for proper operation (see the BOM in Table 7). A complete design schematic compliant to the WPC “Qi” standard is given in Figure 7. It includes WPC “Qi” LED signaling, buzzer, and an EEPROM for loading P9036B firmware.

I2C Communication

The P9036B includes an I2C block which can support either I2C Master or I2C Slave operation. After power-on-reset (POR), the P9036B will initially act as an I2C Master for the purpose of downloading firmware from an external memory device, such as an EEPROM.

The I2C Master mode on the P9036B does not support multi-master mode, and it is important for system designers to avoid any bus master conflict until the P9036B has finished any firmware uploading and has released control of the bus as I2C Master. After firmware downloaded from external memory is complete, and when the P9036B begins normal operation, the P9036B is configured by the standard firmware to be exclusively in I2C Slave mode.

EEPROM

The P9036B EVK supports an external EEPROM memory chip, pre-programmed with a standard operating firmware that is automatically loaded when 5V power is applied. The P9036B uses I2C master address 0x52 to access the EEPROM. The P9036B slave address is 0x39. If the standard firmware is not suitable for the application, a custom EEPROM or internal factory programmed ROM is possible.

For future flexibility, the P9036B will first sequentially try to communicate with the EEPROM first using address 0x50, then 0x52, and finally 0x54. Each address supports a different formatting of the EEPROM data. At this time, the only supported format is at address 0x52. When the P9036B receives a response from the EEPROM, the

sequencing will stop and the P9036B will use the firmware that is up loaded from that address.

Overview of Standard GPIO Usage

There are 7 GPIO’s on the P9036B transmitter IC, of which two are available for use as follows:

- GPIO0,2,6: Selects one of the three available coils.
- GPIO1,5: Manages the demodulation signal selection.
- GPIO3: Green LED and external resistors for choosing LED mode.
- GPIO4: Red LED and AC or DC buzzer (optional) and external resistors for choosing FOD offset option.

Table 8 table lists how the red and green LEDs can be used to display information about the P9036B’s operating modes. The table also includes information about external resistors or internal pull up/down options to select LED modes.

LED FUNCTIONS

Two GPIOs are used to drive LEDs, which indicate, through various on/off and illumination options, the state of charging and some possible fault conditions.

As shown in Figure 8, one or two resistors configure the defined LED option combinations. The DC voltage set in this way is read one time during power-on to determine the LED configuration.

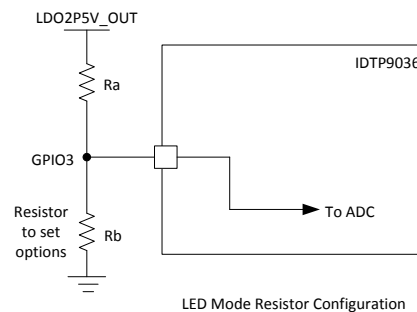

Figure 8 P9036B LED Resistor Options.

Table 8 – P9036B LED Functions

LED Control Option	LED Select GPIO3 Voltage	Description	LED #/ Color	Operational Status					
				Standby	Transfer	Complete	CS100	Low-Power	Fault
1	Pull Down ≤0.080V	Dual-LED, Standby - On Blink	LED1- Green	On	Blink 1Hz	On	Blink 0.5Hz	Blink 2Hz	OFF
			LED2- Red	On	Off	Off	Off	Off	Blink 4Hz
2	0.220V	Dual LED, Standby - On No-Blink	LED1- Green	On	On	Off	Blink 0.5Hz	Blink 2Hz	OFF
			LED2- Red	On	Off	Off	Off	Off	Blink 4Hz
3	0.370V	Single-LED, Standby OFF Blink	LED1- Green	Off	Blink 1Hz	On	Blink 0.5Hz	Blink 2Hz	Blink 4Hz
			LED2- n/a	-	-	-	-	-	-
4	0.510V	Single-LED, Standby OFF No Blink	LED1- Green	Off	On	Off	Blink 0.5Hz	Blink 2Hz	Blink 4Hz
			LED2- n/a	-	-	-	-	-	-
5	0.660V	Dual LED, Standby - Off No-Blink	LED1- Green	Off	On	Off	Blink 0.5Hz	Blink 2Hz	Off
			LED2- Red	Off	Off	Off	Off	Off	Blink 4Hz
6	0.810V	Dual LED, Standby - Off Red Indicate, No-Blink	LED1- Green	Off	Off	On	Off	Off	Off
			LED2- Red	Off	On	Off	Blink 0.5Hz	Blink 2Hz	Blink 4Hz
7	1.000V	Reserved	LED1- Green						
			LED2- Red						
8	1.100V	Reserved	LED1- Green						
			LED2- Red						
9	1.250V	Reserved	LED1- Green						
			LED2- Red						
10	Pull Up ≥1.500V	Dual-LED, Standby - Off Blink	LED1- Green	Off	Blink 1Hz	On	Blink 0.5Hz	Blink 2Hz	Off
			LED2- Red	Off	Off	Off	Off	Off	Blink 4Hz

Note 1 - Voltage divider on GPIO3 should use 1% resistors with parallel impedance approximately 20k-50k.

CS100 is indicated when Rx sends "Charge Status 100" message. Normal indication resumes after Rx sends "Charge Status 90" or less.

CS100 Blink is approximately 68% on-time

"Low Power" is indicated in USB powered applications when USB does not provide sufficient DC power

"Low Power" Blink is approximately 80% on-time

Note 2 - LED Select voltage should be within ±3% of listed value.

Buzzer Function

An optional buzzer feature is supported on GPIO4 which is able to drive directly a piezoelectric type transducer without amplification. As shown on the reference schematic, a series current limiting resistor should be included if a buzzer device is included. The buzzer signal is approximately a 2kHz square wave, and it is recommended to use a buzzer with a 2kHz resonant frequency for best results.

Buzzer Action: Power Transfer Indication

The P9036B supports audible notification when the device operation successfully reaches the Power Transfer state. The duration of the Power Transfer indication sound is approximately 200ms.

Buzzer Action: Charge Complete Indication

The P9036B supports audible notification when the receiver sends a "Charge Complete" during the power transfer state. If "Charge Complete" is sent as the very first packet before being in the power transfer state, there is no buzzer indication for this case. The duration of the "Charge Complete" indication sound is approximately 200ms.

Decoupling/Bulk Capacitors

As with any high-performance mixed-signal IC, the P9036B must be isolated from the system power supply noise to perform optimally. A decoupling capacitor of 0.1µF must be connected between each power supply and the PCB ground plane as close to these pins as possible. For optimum device performance, the decoupling capacitor must be mounted on the component side of the PCB. Additionally, medium value capacitors in the 22µF

range must be used at the VIN inputs (IN,IN1,IN2) to minimize ripple current and voltage droop due to the large current requirements of the resonant half Half-Bridge driver. The value of the capacitors will decrease as the voltage applied approaches the nominal voltage, due to the ceramic dielectric characteristics. For example, a 22 μ F X7R 25V capacitor's value could be as low as 6 μ F when operating at 13V, depending on the manufacturer.

WPC TX-A6 Coil

The internal half-bridge output connects to three series-resonance circuits made by a WPC triple Type-A6 coil and series resonant capacitors. The selected inductor serves as the primary coil of a loosely-coupled transformer, the secondary of which is the inductor connected to the power receiver.

Resonance Capacitors

The resonance capacitors must be COG type dielectric and have a DC rating of at least 100V. The part numbers are shown in the Bill Of Materials

Buck Converter

The input capacitors (C_{IN}) must be connected directly between the power pins (REG_IN and BUCK5VT_IN) and power PGND pins as near as possible to the IC pins. The output capacitor (C_{OUT}) must be placed as close to the device and power ground pins (PGND) as possible.

The output-sense connection to the feedback pin, BUCK5VT_SNS, must be separated from any power trace. Connect the output-sense trace as close as possible to the load point to avoid additional load regulation errors.

The power traces, including PGND traces, the LX or 5V output traces, and the VIN trace must be kept short, direct and wide to allow large current flow. Use several via pads when routing power lines between layers.

LDOs

Input Capacitor

The input capacitors must be located as physically close as possible to the power pin (LDO2P5V_IN) and power ground (GND). Ceramic capacitors are recommended for their low ESR and small profile. Typically, 10V- or 16V-rated capacitors are recommended.

Output Capacitor

For proper voltage regulation and stability, a capacitor is required on the output of each LDO (LDO2P5V and LDO5V). The output capacitor must be placed as close to the device and power (PGND) pins as possible. Since the LDOs have been designed to function with very low ESR capacitors, a ceramic capacitor is required for best performance.

PCB Layout Considerations

- For optimum device performance and lowest output phase noise, the following guidelines must be observed. Please contact IDT for Gerber files that contain the recommended board layout.
- As for all switching power supplies, especially those providing high current and using high switching frequencies, layout is an important design step. If layout is not carefully done, the regulator could show instability as well as EMI problems. Therefore, use wide and short traces for high current paths. If there are any uncertainties regarding best layout practices it is best to follow the provided, optimized IDT layout.
- The 0.1 μ F decoupling capacitors must be mounted on the component side of the board as close as possible to the pins intended to be decoupled. Keep PCB traces to each power pin and to ground vias as short as possible.
- To optimize board layout, place all components on the same side of the board.
- All passive components in the network connecting to the HPF pin, up to and including the three small signal diodes must be placed close to the HPF pin. This is a high sensitivity analog circuit, and traces with high voltage or high noise must be routed away from this area. It is especially important to mount the capacitor connecting to the HPF pin as close as possible to the HPF pin. Additionally, the HPF pin is a high impedance input and any DC leakage into this node can reduce performance.

Product Datasheet

- The NQG48 6.0mm x 6.0mm x 0.75mm 48L package has an inner thermal pad, which requires blind assembly. It is recommended that a more active flux solder paste be used such as Alpha OM-350 solder paste from Cookson Electronics (<http://www.cooksonsemi.com>). Please contact IDT for Gerber files that contain recommended solder stencil design.
- The package center exposed pad (EP) must be reliably soldered directly to the PCB. The center land pad on the PCB must also be tied to the board ground plane, primarily to maximize thermal performance in the application. The ground connection is best achieved using a matrix of plated-through-hole (PTH) vias embedded in the PCB center land pad for the NTG48. The PTH vias perform as thermal conduits to the ground plane (thermally, a heat spreader) from the solder side of the board.
- On the solder side of the board, these thermal vias embed in a copper fill having the same dimensions as the center land pad on the component side. Recommendations for the via finished hole-size and array pitch are 0.3mm to 0.33mm and 1.3mm, respectively.

Power Dissipation/Thermal Requirements

The P9036B is offered in a TQFN-48L package. The maximum power dissipation capability is 1.3W, limited by the die's specified maximum operating junction temperature, T_J , of 125°C.

The junction temperature rises with the device power dissipation based on the package thermal resistance. The package offers a typical thermal resistance, junction to ambient (θ_{JA}), of 31°C/W when the PCB layout and surrounding devices are optimized as described in the PCB Layout Considerations section. The techniques as noted in the PCB Layout section need to be followed when designing the printed circuit board layout.

Care should be exercised to avoid the placement of the P9036B IC package in proximity to other heat generating devices in a given application design. The ambient temperature around the power IC will also have an effect on the thermal limits of an application.

The overall goal is to have as much uninterrupted copper material on both the top and bottom layers of the PCB to carry away heat away for the P9036B as quickly as possible.

Special Notes**NQG TQFN-48 Package Assembly**

Note 1: Unopened Dry Packaged Parts have a one year shelf life.

Note 2: The HIC indicator card for newly opened Dry Packaged Parts should be checked. If there is any moisture content, the parts must be baked for a minimum of 8 hours at 125°C within 24 hours of the assembly reflow process.

PACKAGE OUTLINE DRAWING

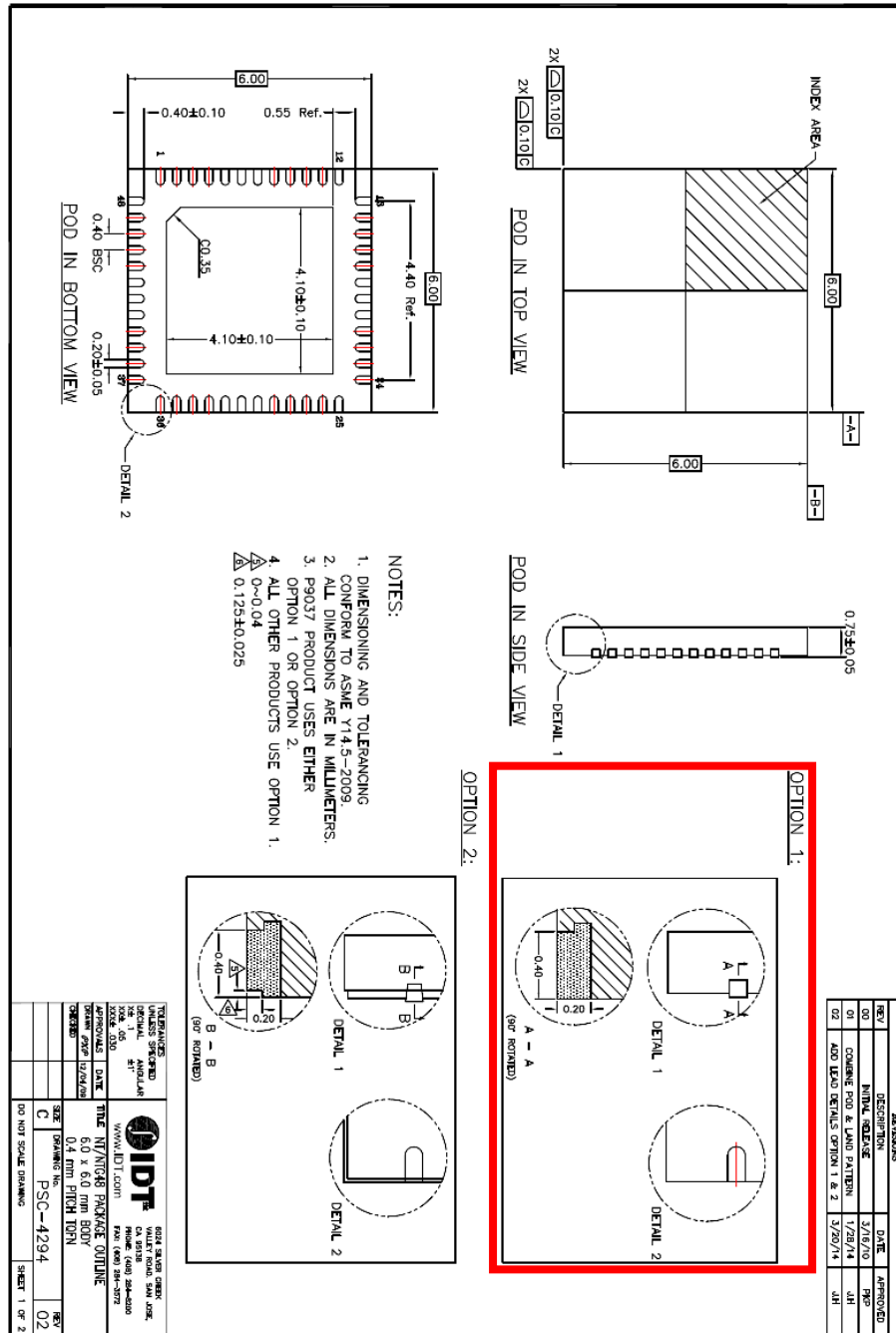

Figure 9 P9036B Package Outline Drawing (NTG48 TQFN-48L 6.0 mm x 6.0 mm x 0.75 mm 48L, 0.4mm pitch)

ORDERING GUIDE

Table 9 Ordering Summary

PART NUMBER	MARKING	PACKAGE	AMBIENT TEMP. RANGE	SHIPPING CARRIER	QUANTITY
P9036BNTGI	P9036BNTG	NTG48 - TQFN-48 6x6x0.75mm	-40°C to +85°C	Tray	25
P9036BNTGI8	P9036BNTG	NTG48 - TQFN-48 6x6x0.75mm	-40°C to +85°C	Tape and Reel	2,500

IMPORTANT NOTICE AND DISCLAIMER

RENESAS ELECTRONICS CORPORATION AND ITS SUBSIDIARIES (“RENESAS”) PROVIDES TECHNICAL SPECIFICATIONS AND RELIABILITY DATA (INCLUDING DATASHEETS), DESIGN RESOURCES (INCLUDING REFERENCE DESIGNS), APPLICATION OR OTHER DESIGN ADVICE, WEB TOOLS, SAFETY INFORMATION, AND OTHER RESOURCES “AS IS” AND WITH ALL FAULTS, AND DISCLAIMS ALL WARRANTIES, EXPRESS OR IMPLIED, INCLUDING, WITHOUT LIMITATION, ANY IMPLIED WARRANTIES OF MERCHANTABILITY, FITNESS FOR A PARTICULAR PURPOSE, OR NON-INFRINGEMENT OF THIRD PARTY INTELLECTUAL PROPERTY RIGHTS.

These resources are intended for developers skilled in the art designing with Renesas products. You are solely responsible for (1) selecting the appropriate products for your application, (2) designing, validating, and testing your application, and (3) ensuring your application meets applicable standards, and any other safety, security, or other requirements. These resources are subject to change without notice. Renesas grants you permission to use these resources only for development of an application that uses Renesas products. Other reproduction or use of these resources is strictly prohibited. No license is granted to any other Renesas intellectual property or to any third party intellectual property. Renesas disclaims responsibility for, and you will fully indemnify Renesas and its representatives against, any claims, damages, costs, losses, or liabilities arising out of your use of these resources. Renesas' products are provided only subject to Renesas' Terms and Conditions of Sale or other applicable terms agreed to in writing. No use of any Renesas resources expands or otherwise alters any applicable warranties or warranty disclaimers for these products.

(Disclaimer Rev.1.0 Mar 2020)

Corporate Headquarters

TOYOSU FORESIA, 3-2-24 Toyosu,
Koto-ku, Tokyo 135-0061, Japan
www.renesas.com

Contact Information

For further information on a product, technology, the most up-to-date version of a document, or your nearest sales office, please visit:
www.renesas.com/contact/

Trademarks

Renesas and the Renesas logo are trademarks of Renesas Electronics Corporation. All trademarks and registered trademarks are the property of their respective owners.