

REVISIONS					
REV	DATE	DESCRIPTION	BY	CHK	APPV
Y1	29SEP2022	REVISED PER ECN-22-177079	RK	MF	

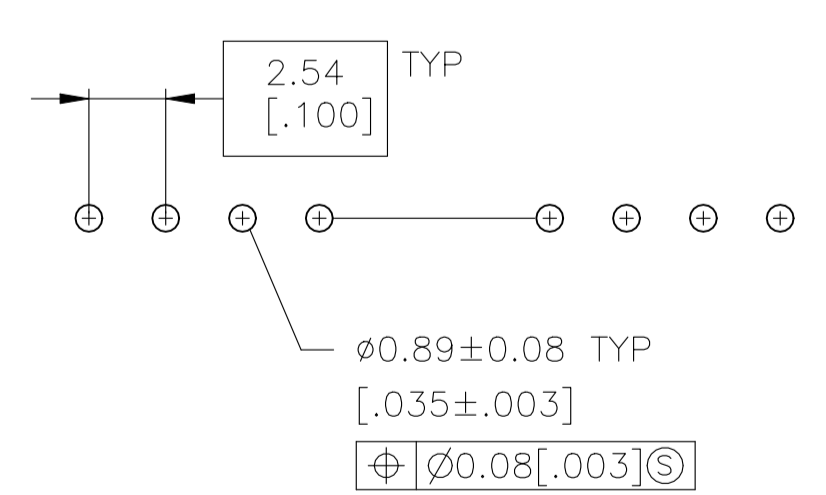
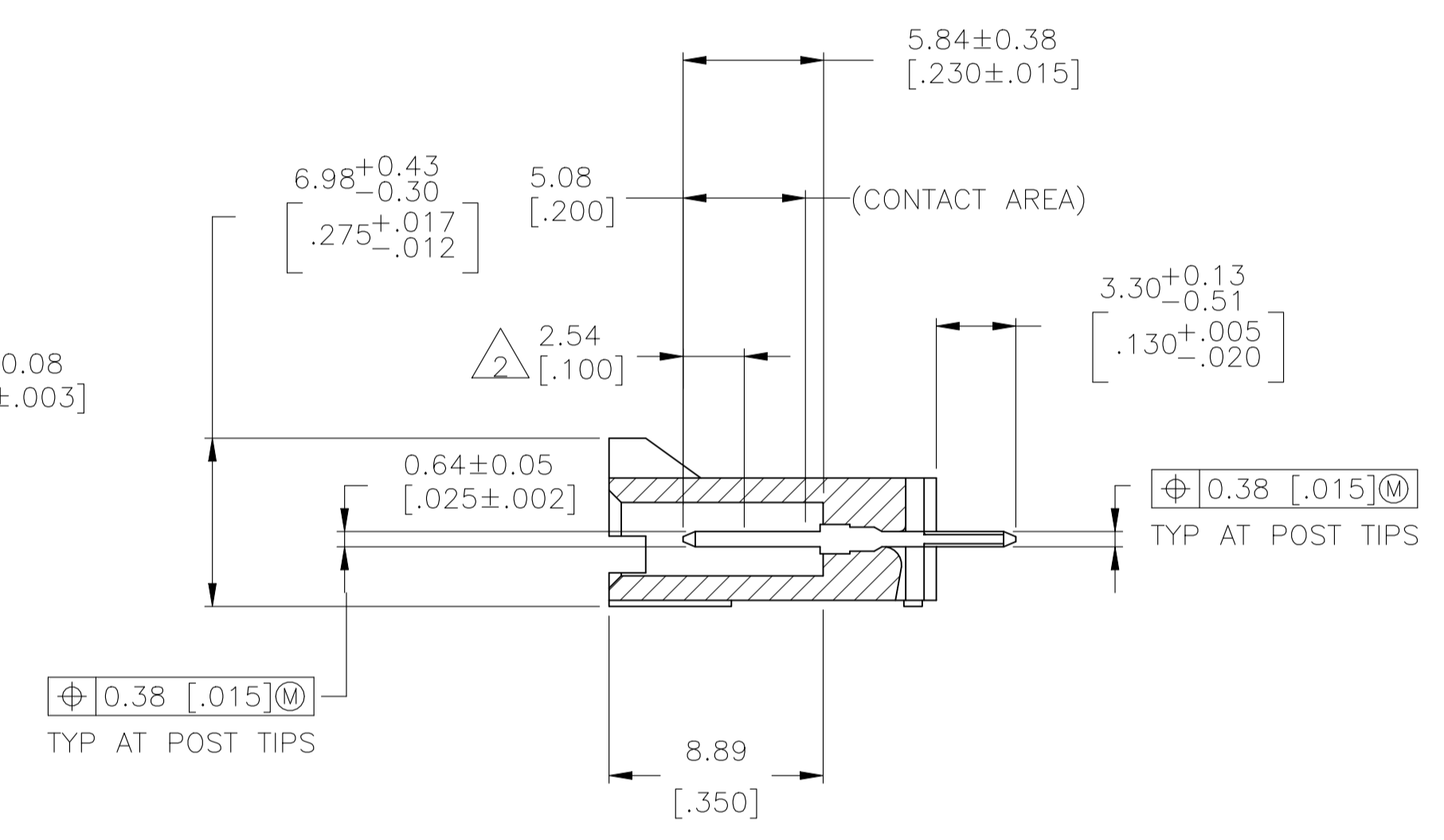
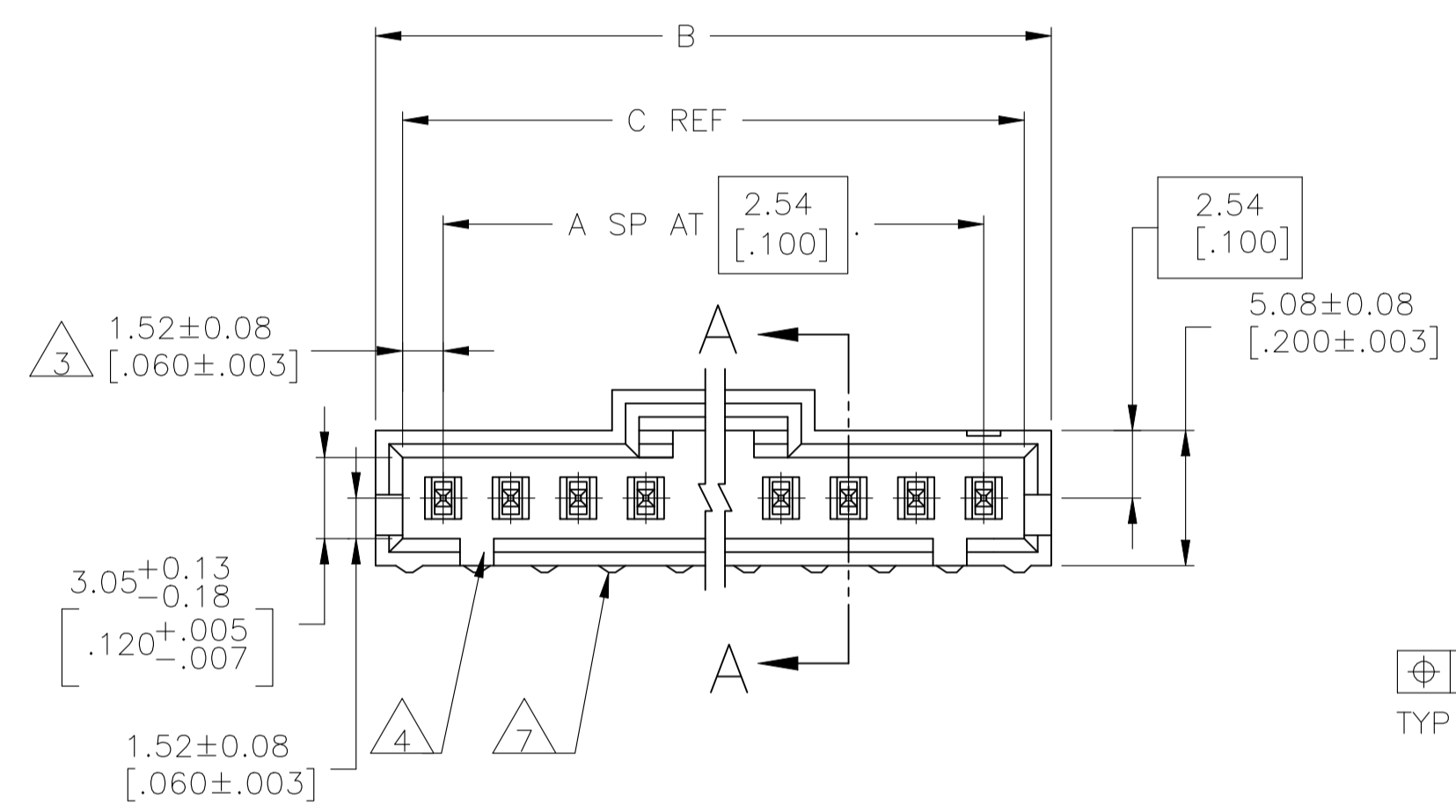
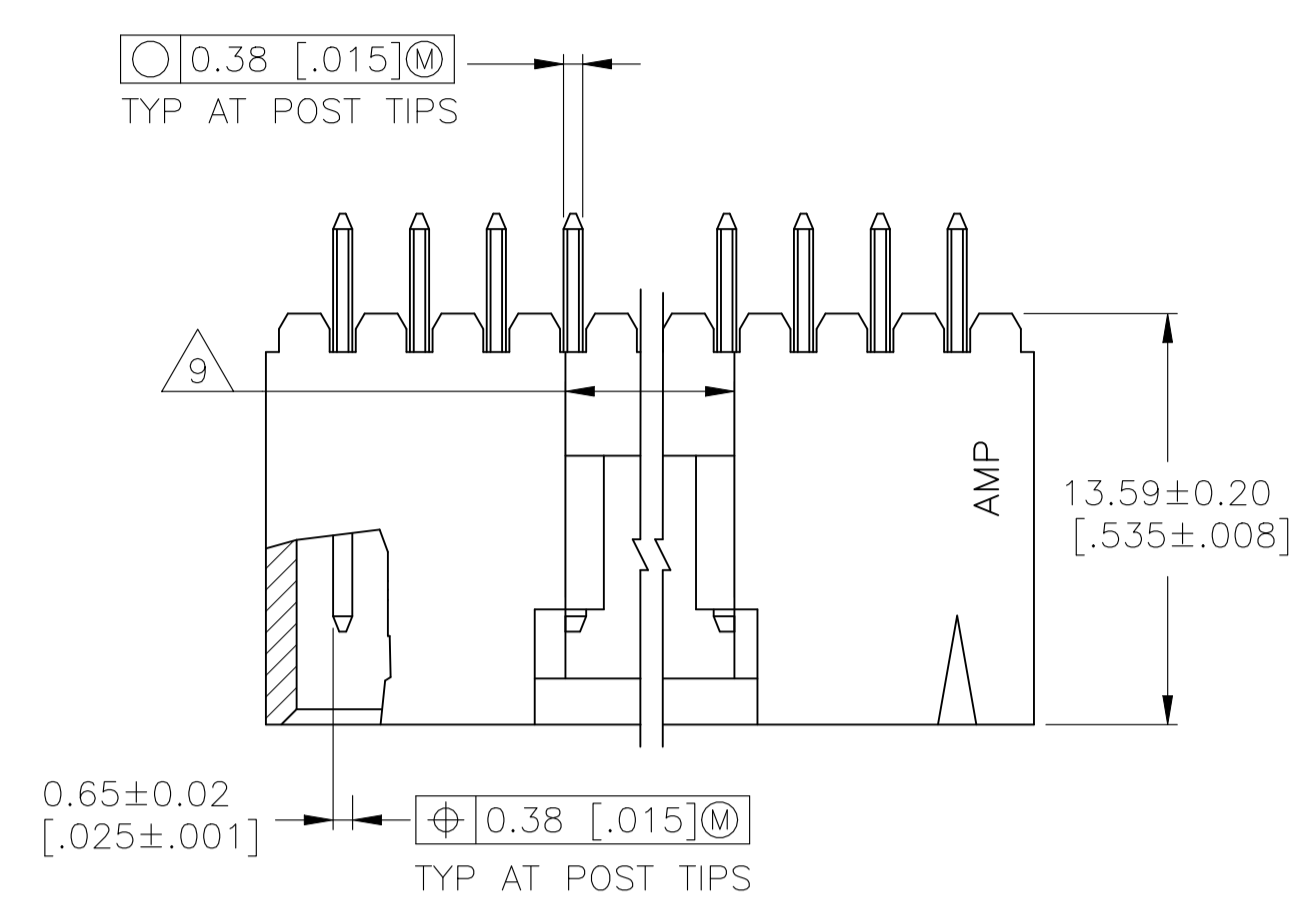

RECOMMENDED HOLE LAYOUT

- 1 .00076[.000030] GOLD IN THE CONTACT AREA, .00254[.000100] MATTE TIN-LEAD ON REMAINDER OF CONTACT, ALL OVER .00127[.000050] NICKEL.
- 2 POINT OF MEASUREMENT FOR PLATING THICKNESS.
- 3 THE NOTED DIMENSIONS APPLY AT THE INTERSECTION OF THE POST AND THE HOUSING.
- 4 ON ASSEMBLIES WITH FOUR OR MORE POSITIONS, TWO POLARIZATION SLOTS. ON ASSEMBLIES WITH TWO OR THREE POSITIONS, ONE POLARIZATION SLOT.
- 5 .00076[.000030] GOLD IN THE CONTACT AREA, .00254[.000100] MATTE TIN ON REMAINDER OF CONTACT, ALL OVER .00127[.000050] NICKEL.
- 6 HIGH TEMPERATURE CONFIGURATION
- 7 STANDOFFS NOT PRESENT ON UNDERSIDE OF ASSEMBLY
- 8 OBSOLETE PARTS: OBSOLETE CIS STREAMLINING PER D.RENAUD/D.SINISI
- 9 0.25 [.010] RECESS PERMISSIBLE IN THIS AREA FOR MOLD SHUT OFF

REV	DATE	DESCRIPTION	BY	CHK	APPV	REV	DATE	DESCRIPTION	BY	CHK	APPV
6						64.01	65.91	24	25		2-103735-4
8		OBSOLETE				61.47	63.37	23	24		-2-103735-3
8		OBSOLETE				58.93	60.83	22	23		-2-103735-2
8		OBSOLETE				56.39	58.29	21	22		-2-103735-1
8		OBSOLETE				53.85	55.75	20	21		-2-103735-0
6						51.31	53.21	19	20		1-103735-9
8		OBSOLETE				48.77	50.67	18	19		-1-103735-8
6						46.23	48.13	17	18		1-103735-7
6						43.69	45.59	16	17		1-103735-6
6						41.15	43.05	15	16		1-103735-5
6						38.61	40.51	14	15		1-103735-4
6						36.07	37.97	13	14		1-103735-3
6						33.53	35.43	12	13		1-103735-2
6						30.99	32.89	11	12		1-103735-1
6						28.45	30.35	10	11		1-103735-0
6						25.91	27.81	9	10		103735-9
6						23.37	25.27	8	9		103735-8
6						20.83	22.73	7	8		103735-7
6						18.29	20.19	6	7		103735-6
6						15.75	17.65	5	6		103735-5
6						13.21	15.11	4	5		103735-4
6						10.67	12.57	3	4		103735-3
6						8.13	10.03	2	3		103735-2
6						5.59	7.49	1	2		103735-1

REMARKS	PLATING	C	B	A	NO. OF POSN	PART NO.

THIS DRAWING IS A CONTROLLED DOCUMENT.		DIN 3-5-91	TE Connectivity Ltd.
DIMENSIONS: mm [INCHES]		3-27-91	
TOLERANCES UNLESS OTHERWISE SPECIFIED:		3-27-91	
0. PLC	±		
1. PLC	±		
2. PLC	±	0.13[.005]	
3. PLC	±		
4. PLC	±		
ANGLES	±		
MATERIAL: HOUSING: POLY-ETHER-ETHER-ETHER; SOLDER: SOLDER-BLACK; CONTACTS: BRASS		WEIGHT: --	RESTRICTED TO
FINISH: SEE TABLE		SIZE: A1	
		CAGE CODE: 00779	
		DRAWING NO: 103735	
		CUSTOMER DRAWING	
		SCALE: 4:1	
		SHEET: 1 OF 2	
		REV: Y1	

REVISIONS					
REV	DATE	DESCRIPTION	BY	CHK	APPV
-	-	SEE SHEET 1	-	-	-

		△6	△7	△5	64.01 [2.520]	65.91 [2.595]	24	25	7-103735-4
△8	OBSOLETE	△6	△7	△5	61.47 [2.420]	63.37 [2.495]	23	24	-7-103735-3
△8	OBSOLETE	△6	△7	△5	58.93 [2.320]	60.83 [2.395]	22	23	-7-103735-2
△8	OBSOLETE	△6	△7	△5	56.39 [2.220]	58.29 [2.295]	21	22	-7-103735-1
△8	OBSOLETE	△6	△7	△5	53.85 [2.120]	55.75 [2.195]	20	21	-7-103735-0
		△6	△7	△5	51.31 [2.020]	53.21 [2.095]	19	20	6-103735-9
△8	OBSOLETE	△6	△7	△5	48.77 [1.920]	50.67 [1.995]	18	19	-6-103735-8
△8	OBSOLETE	△6	△7	△5	46.23 [1.820]	48.13 [1.895]	17	18	-6-103735-7
		△6	△7	△5	43.69 [1.720]	45.59 [1.795]	16	17	6-103735-6
		△6	△7	△5	41.15 [1.620]	43.05 [1.695]	15	16	6-103735-5
		△6	△7	△5	38.61 [1.520]	40.51 [1.595]	14	15	6-103735-4
		△6	△7	△5	36.07 [1.420]	37.97 [1.495]	13	14	6-103735-3
△8	OBSOLETE	△6	△7	△5	33.53 [1.320]	35.43 [1.395]	12	13	-6-103735-2
		△6	△7	△5	30.99 [1.220]	32.89 [1.295]	11	12	6-103735-1
		△6	△7	△5	28.45 [1.120]	30.35 [1.195]	10	11	6-103735-0
		△6	△7	△5	25.91 [1.020]	27.81 [1.095]	9	10	5-103735-9
		△6	△7	△5	23.37 [.920]	25.27 [0.995]	8	9	5-103735-8
		△6	△7	△5	20.83 [.820]	22.73 [.895]	7	8	5-103735-7
		△6	△7	△5	18.29 [.720]	20.19 [.795]	6	7	5-103735-6
		△6	△7	△5	15.75 [.620]	17.65 [.695]	5	6	5-103735-5
		△6	△7	△5	13.21 [.520]	15.11 [.595]	4	5	5-103735-4
		△6	△7	△5	10.67 [.420]	12.57 [.495]	3	4	5-103735-3
		△6	△7	△5	8.13 [.320]	10.03 [.395]	2	3	5-103735-2
		△6	△7	△5	5.59 [.220]	7.49 [.295]	1	2	5-103735-1
	REMARKS	PLATING	C	B	A	NO. OF POSN	PART NO.		

THIS DRAWING IS A CONTROLLED DOCUMENT.		DIN S. SHUEY 3-5-91	 TE Connectivity Ltd.
		CHK: L. CASTAGNA 3-27-91	
DIMENSIONS: mm [INCHES]	TOLERANCES UNLESS OTHERWISE SPECIFIED:	APVD: L. CASTAGNA 3-27-91	NAME: HDR ASSY, VERT, SINGLE ROW
0. PLC ± - 1. PLC ± - 2. PLC ± - 3. PLC ± - 4. PLC ± - ANGLES ± -	MATERIAL: HOUSING: TANK REMAINT (OR COULR-BLACK) CONTACTS: BRASS FINISH: SEE TABLE	PRODUCT SPEC: APPLICATION SPEC: WEIGHT:	RESTRICTED TO: SIZE: A1 CAGE CODE: 00779 DRAWING NO: 103735
CUSTOMER DRAWING		SCALE: 4:1	SHEET 2 OF 2