

50 Ohm SMB

Straight Crimp Type Bulkhead Jack - Solder or Crimp Captivated Contact

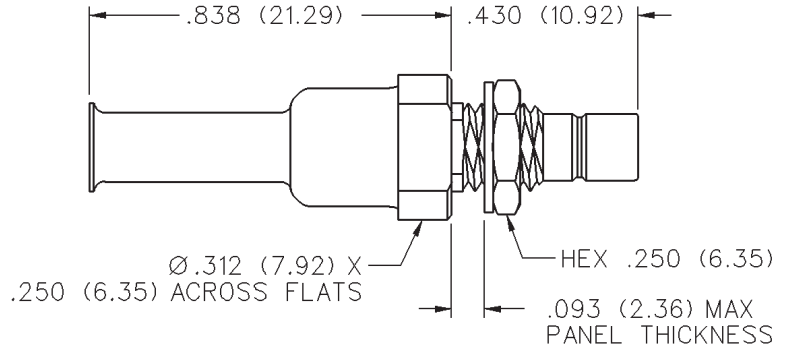

INCHES (MILLIMETERS)
CUSTOMER DRAWINGS AVAILABLE UPON REQUEST



CABLE TYPE	GOLD PLATED	NICKEL PLATED
RG-161/U, 174, 179, 187, 188, 316	131-3303-401	131-3303-406

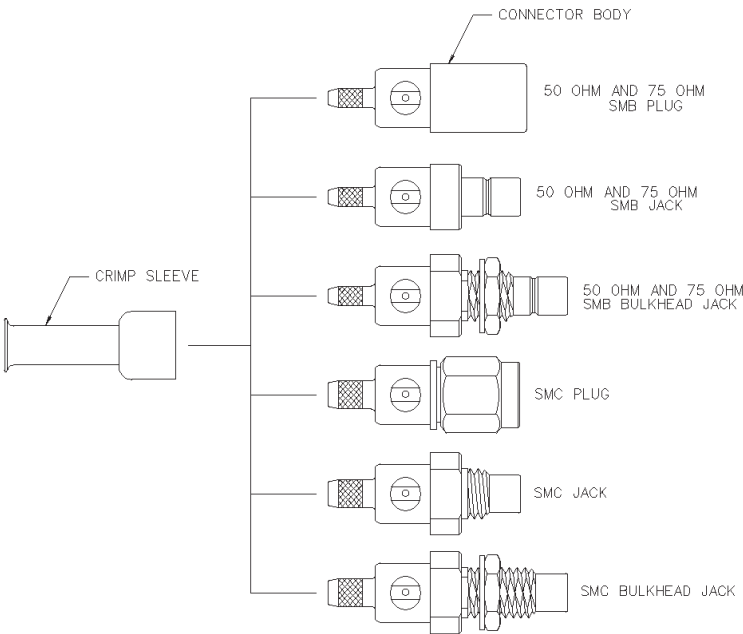

Mounting hole layout

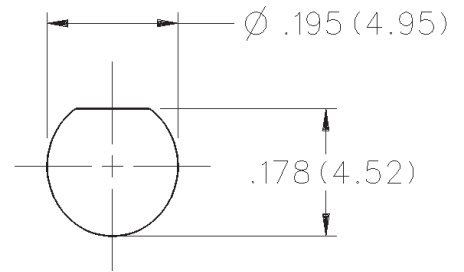

CABLE GROUP	PART NUMBER	CRIMP HEX
RG-316/u, 161, 174, 179, 187, 188	131-3303-401/406	.128 (3.25)

1. Identify connector parts. (2 piece parts - except bulkhead)
2. Strip cable to dimensions shown. Do not nick braid or center conductor. A wire stripper of correct size is recommended for this step. Twist stranded center conductor into tight bundle and tin. Slide crimp sleeve onto cable as shown.
3. Flare braid and slide cable into body making certain that the cable insulation bottoms in center contact.

Solder Attachment: Solder center conductor to contact through the side access ports and hole in center contact. Use a minimum amount of solder for a full fillet joint. **.020 (0.51) diameter solder is recommended.**

Crimp 50 Ohm connector contacts with 141-0000-911 dieset in 144-900 tool frame. Crimp 75 Ohm connector contacts with 141-0000-924 dieset in 144-0000-900 tool frame.

