

NOTES:

1. MATERIAL: BODY - POLYCARBONATE 10% FIBERGLASS REINFORCED
COVER - POLYCARBONATE
UL508 /NEMA TYPE 4X WITH IP-67 TUV RATING & UL-94V0 RATING
2. FINISH: BODY - LIGHT GRAY
COVER - LIGHT GRAY OR CLEAR (-C)
3. CONTINUOUS GASKET IN COVER
4. SUPPLIED WITH SIX LARGE WALL MOUNT BRACKETS
5. SUPPLIED WITH FOURTEEN M6 x 12.7mm LG. TRUSS HEAD MACHINE SCREWS
6. DIMENSIONS ARE INCH [MM]

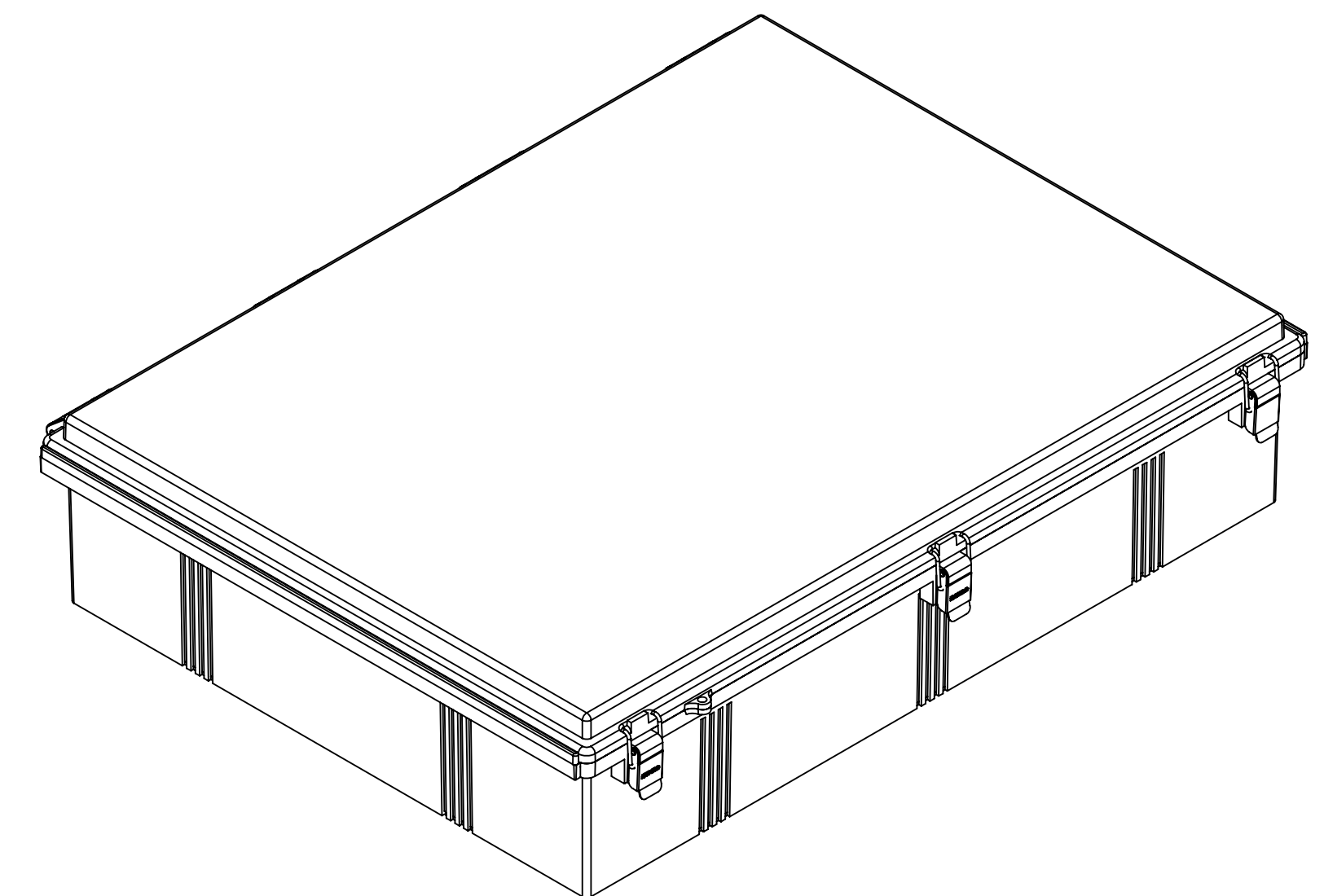
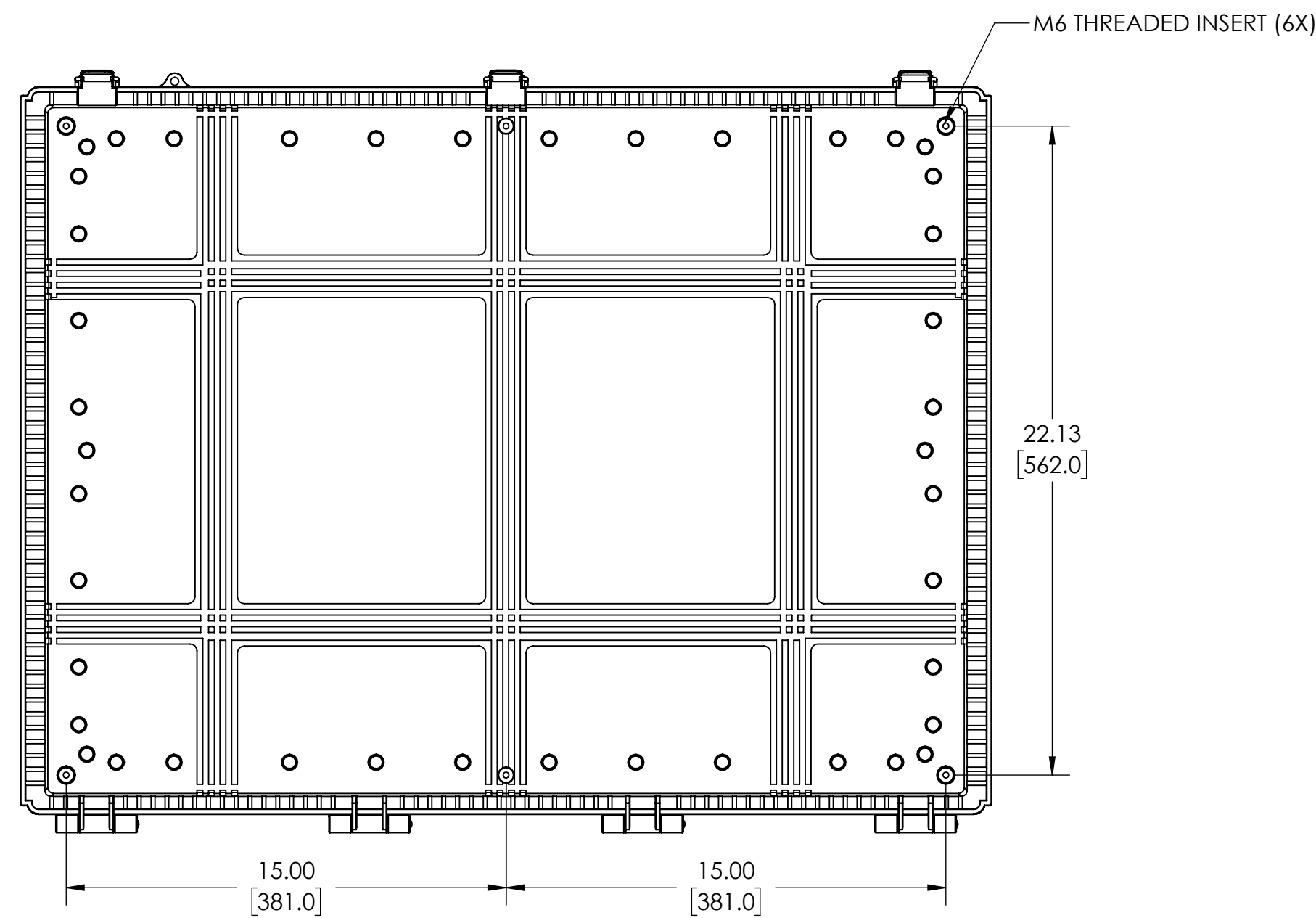
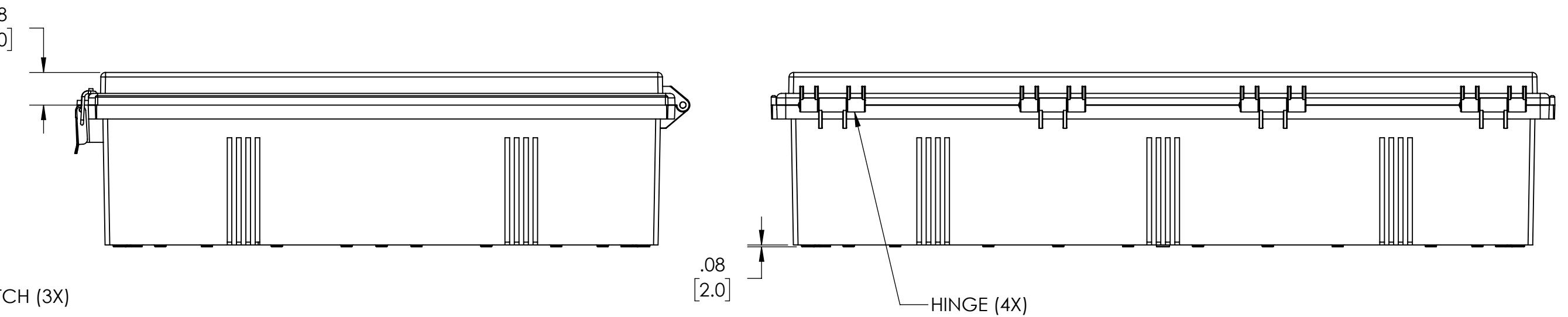
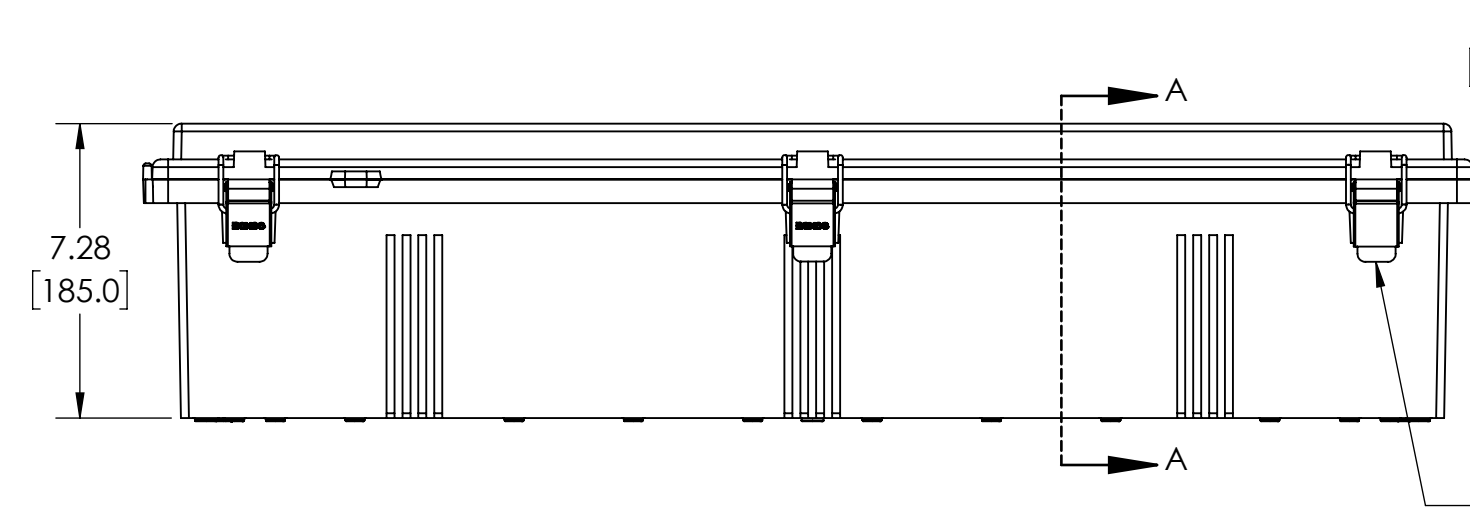
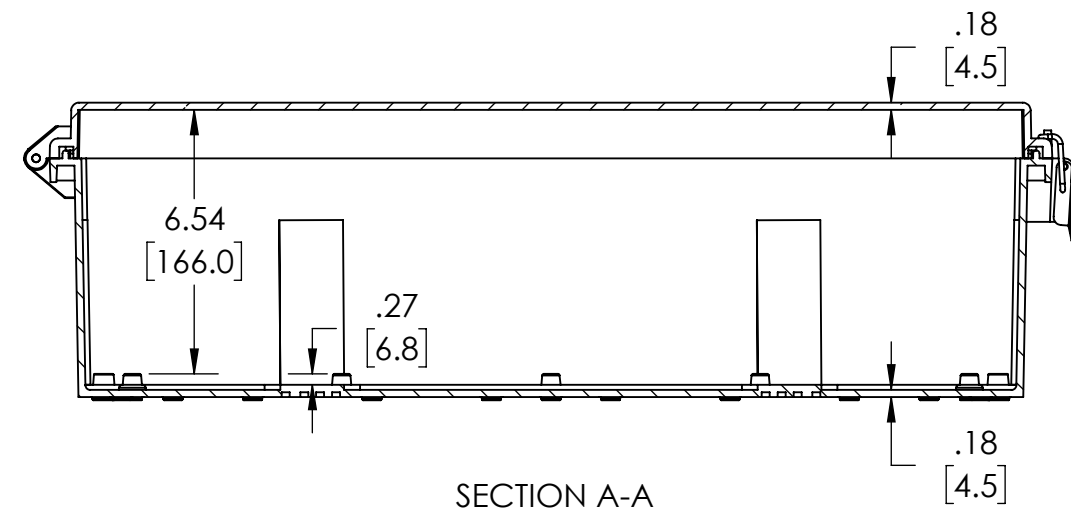
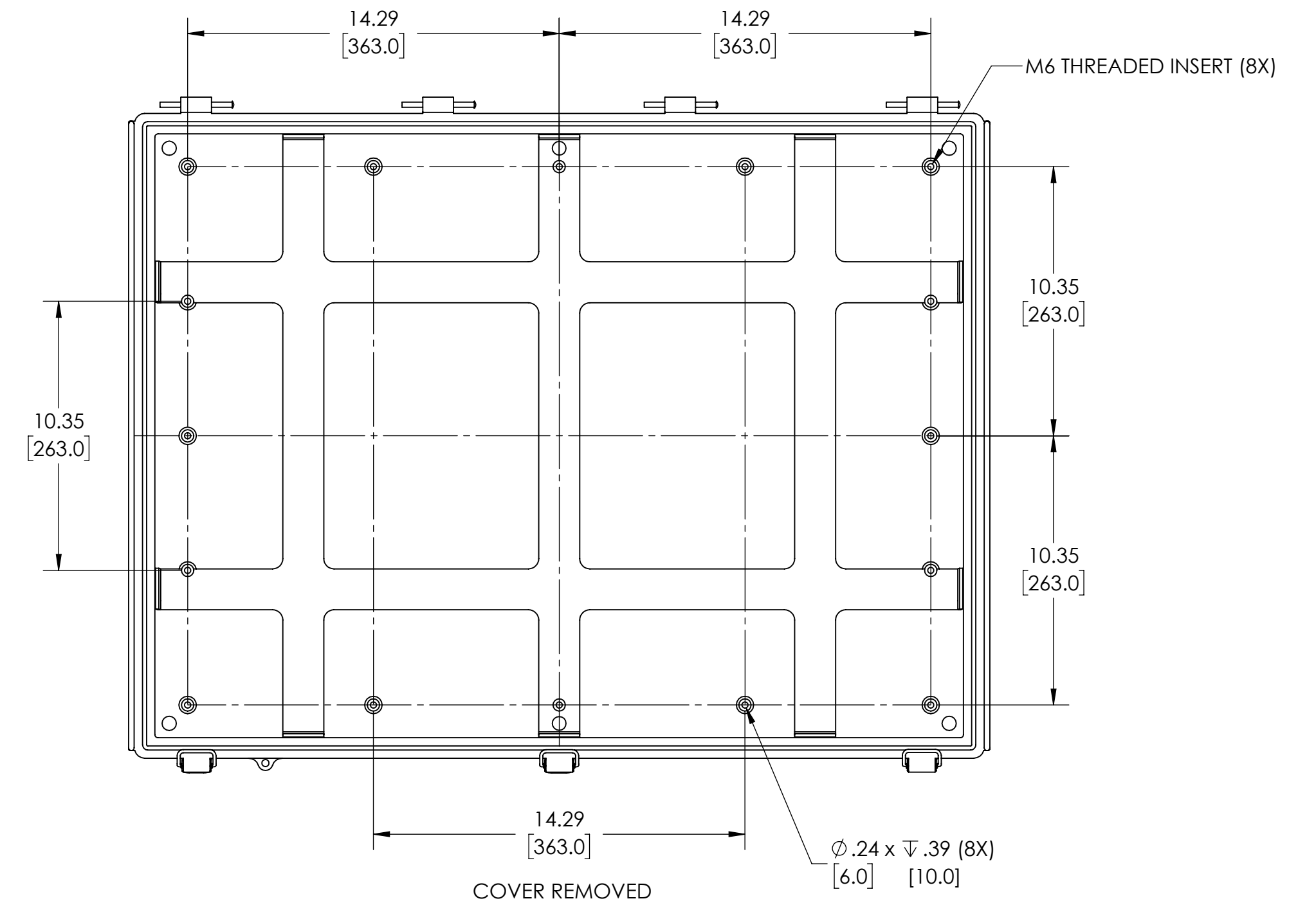
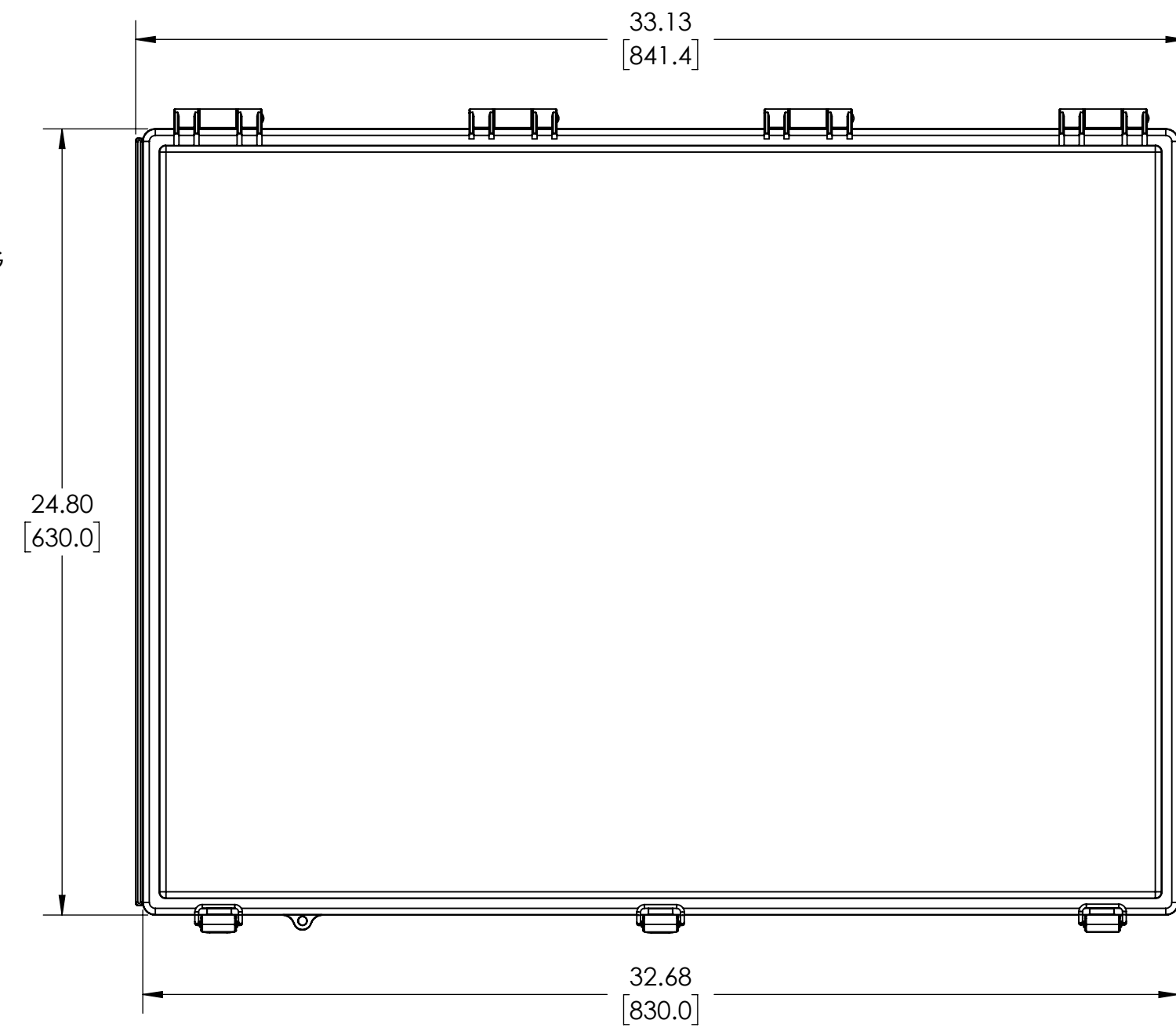

DRAWING FOR REFERENCE

WE RESERVE THE RIGHT TO MAKE CHANGES TO OUR STANDARD PRODUCTS. PLEASE CONSULT WITH BUD INDUSTRIES PRIOR TO USING THIS DRAWING FOR DESIGN PURPOSE.