

REVISIONS				
REV.	ECO. NO	DESCRIPTION	DATE	BY
A	2406	INITIAL RELEASE	08/02/2011	GC

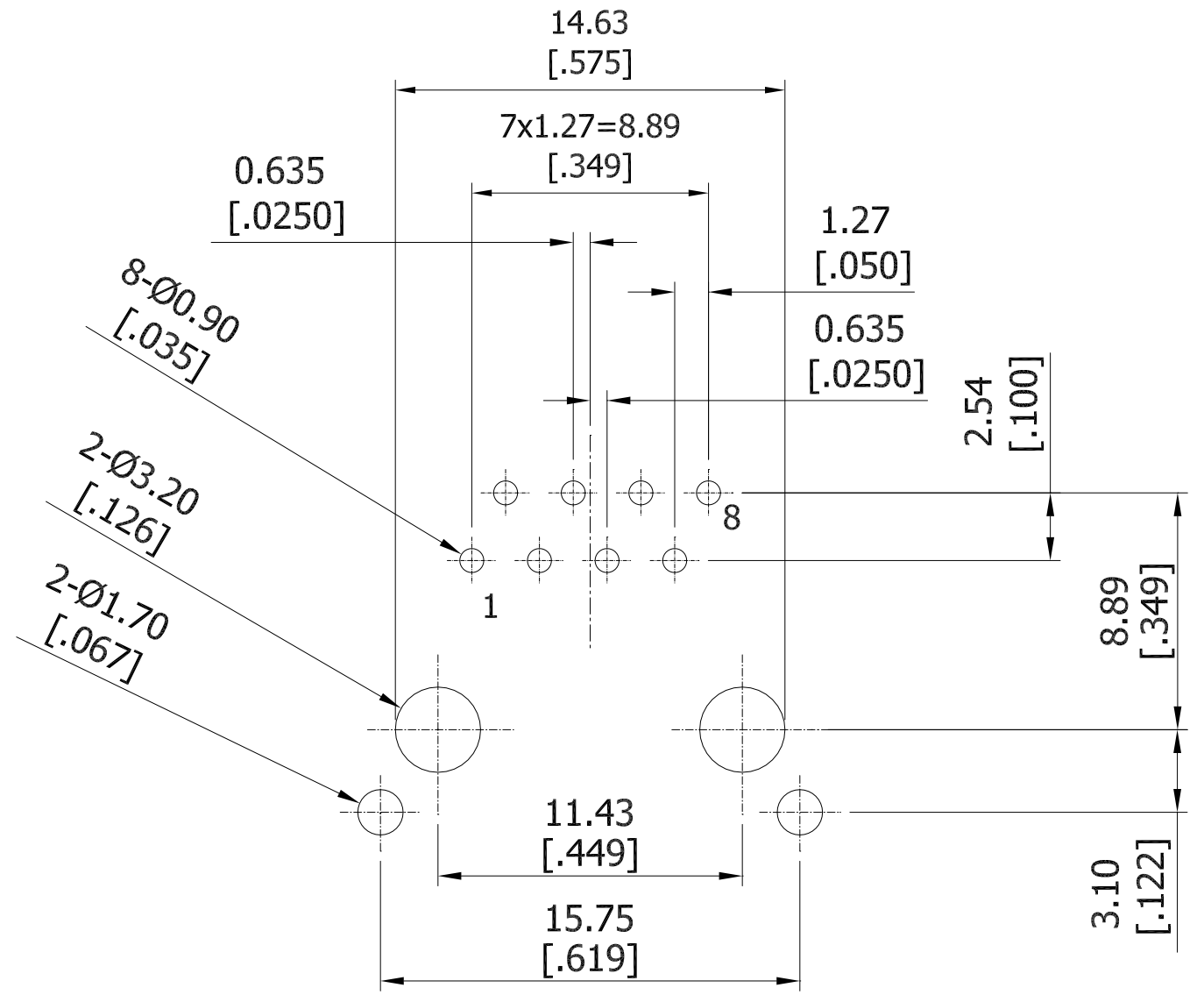

RECOMMENDED P.C.B LAYOUT
TOLERANCE: ±0.05 [0.002]

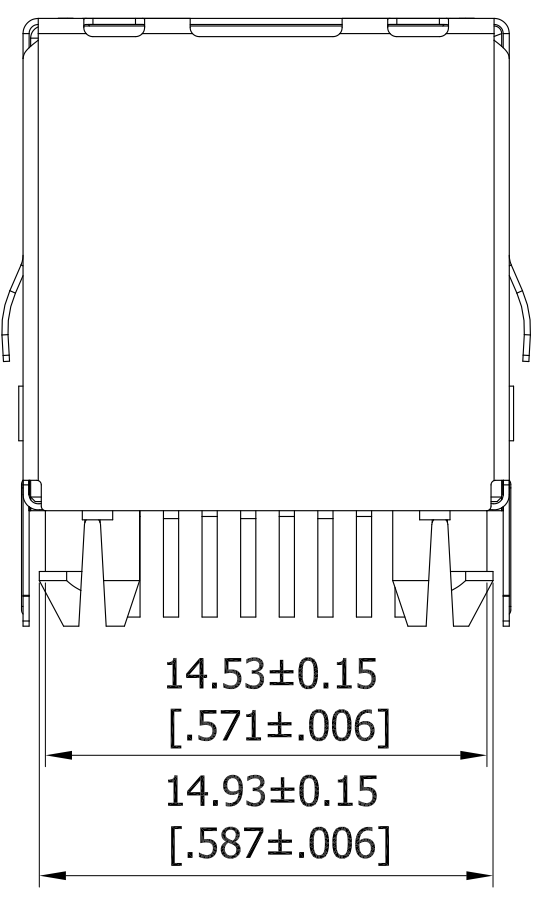
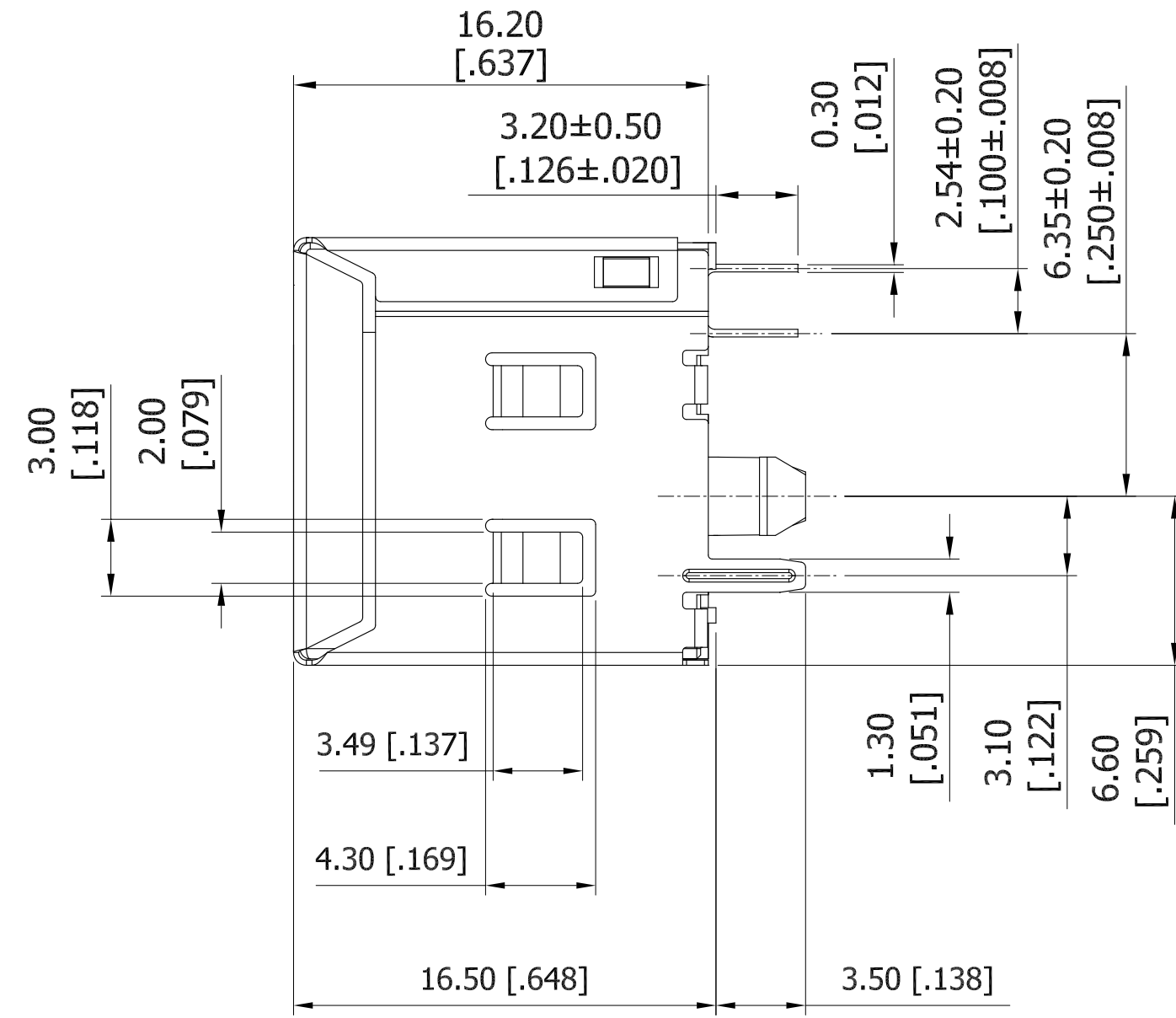
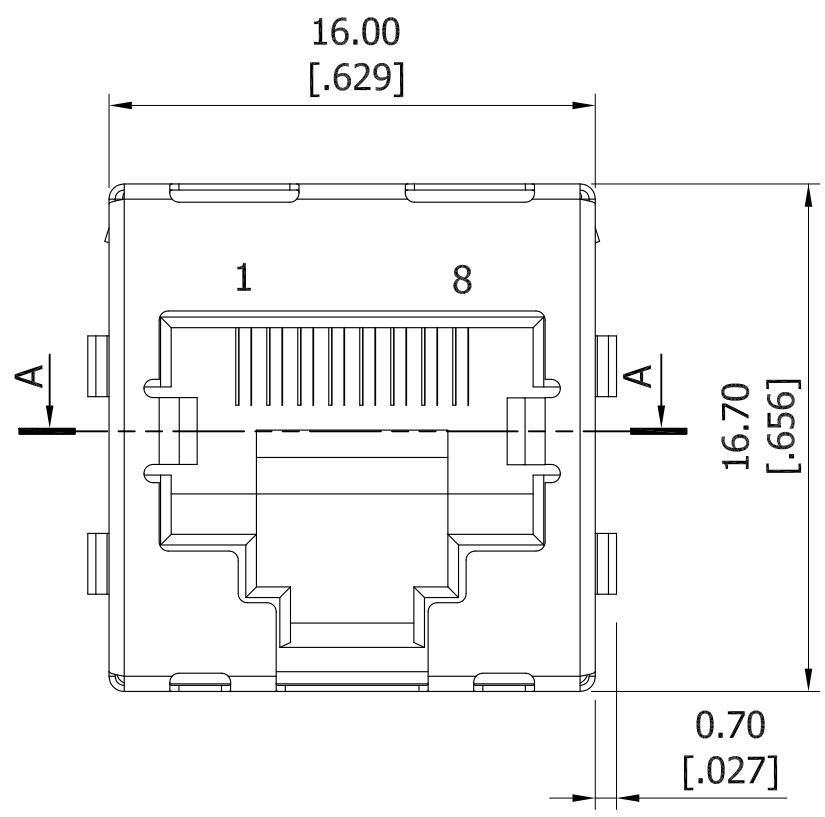
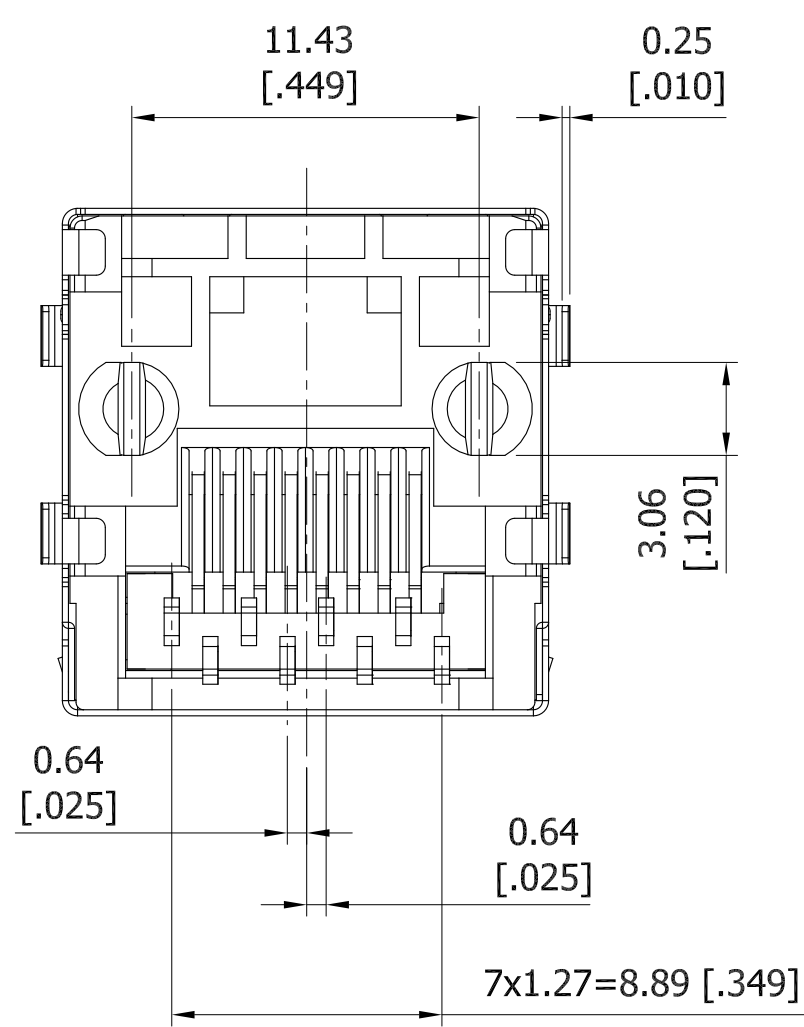

NOTES:

- MATERIAL:
SHELL: 0.20mm THICKNESS BRASS.
HOUSING: THERMOPLASTIC, UL94V-0, COLOR: BLACK.
INSERT: THERMOPLASTIC, UL94V-0, COLOR: BLACK.
TERMINAL: 0.30mm THICKNESS, PHOSPHOR BRONZE.
- PLATING:
TERMINAL:
CONTACT AREA: .000050" GOLD ON CONTACT SURFACE.
SOLDER TAIL: .000100" MIN. TIN ON TERMINATION.
UNDER PLATE: .000050" MIN. NICKEL UNDERPLATE.
SHELL:
UNDER PLATE: .000030" MIN. NICKEL UNDERPLATE.
(SOLDERING AVAILABLE)
SURFACE APPEARANCE: BRIGHT NICKEL.

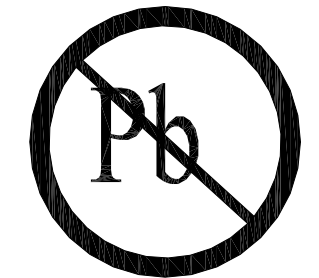

RoHS COMPLIANT

UNLESS OTHERWISE SPECIFIED: DIMENSIONS ARE IN MM [INCHES]	DRAWN	DATE	NAME		TITLE VERTICAL RJ45 WITHOUT TRANSFORMER DIP TYPE PART NUMBER SMJ300-T88N-DS-01
		08/02/2011	GC		
TOLERANCES: .X=± 0.25 [0.01] .XX=± 0.15 [0.006] .XXX=± 0.10 [0.0040]	<small>THE INFORMATION HEREIN CONTAINS PROPRIETARY INFORMATION OF SULLINS ELECTRONICS AND IS NOT TO BE REPRODUCED, USED OR DISCLOSED TO OTHERS FOR ANY PURPOSE EXCEPT AS SPECIFICALLY AUTHORIZED IN WRITING BY AN OFFICER OF SULLINS ELECTRONICS.</small>			SIZE C CAGE CODE 54453 SCALE: 4:1	DWG. NO. 11821 REV A
	<small>INTERPRET DIMENSIONS AND TOLERANCING PER: ASME Y14.5M-2009</small>			SHEET 1 OF 1	