

SERIES

PTHFxxxR-SM
PTKMxxxR-SM
PTHF-SM
PTKM-SM



Surface Mount Toroidal Power Chokes



Actual Size (Max.)
(PTHF 100-50SM)

- Excellent electromagnetic shielding performance for commercial and industrial applications
- For higher saturation levels use Series PTHF-SM
- Current rating from 0.92 to 7.36 amps
- Inductance values from 10 μ H to 330 μ H

Marking API; either PTHF or PTKM; remainder of part number.

Example: PTKM50R-50SM
 API
 PTHF
 50R-50SM

Notes 1) Rated current is based on a 35°C temperature rise at an ambient temperature of 90°C. 2) Incremental current is the approximate value that will cause a percentage drop in inductance as indicated in the table.

DASH NUMBER*	INDUCTANCE @ 1 KHz (μ H) \pm 10%	CURRENT RATING-ADC	Inc-I ADC Δ L 10%	Inc-I ADC Δ L 20%	DC-RESISTANCE MAXIMUM (OHMS)	SRF MINIMUM (MHz)
--------------	--	--------------------	-----------------------------	-----------------------------	---------------------------------	-------------------

SERIES PTHF-SM HIGH SATURATION CORE						
PTHF10-50SM	10	7.36	6.00	8.70	0.01	35.0
PTHF25-50SM	25	5.20	3.60	5.30	0.02	10.0
PTHF50-50SM	50	3.93	2.00	3.10	0.04	7.0
PTHF75-50SM	75	3.47	1.60	2.50	0.05	5.0
PTHF100-50SM	100	3.14	1.50	2.20	0.06	4.0
PTHF150-50SM	150	2.33	1.20	1.80	0.10	3.0
PTHF200-50SM	200	1.97	1.00	1.60	0.14	2.0
PTHF250-50SM	250	1.84	0.90	1.40	0.16	1.5
PTHF330-50SM	330	1.69	0.80	1.20	0.19	1.0
PTHF10-40SM	10	4.84	3.80	5.70	0.02	35.0
PTHF25-40SM	25	3.38	2.20	3.50	0.04	20.0
PTHF50-40SM	50	1.90	1.70	2.50	0.11	13.0
PTHF75-40SM	75	1.69	1.30	2.00	0.14	9.0
PTHF100-40SM	100	1.60	1.10	1.70	0.16	6.0
PTHF150-40SM	150	1.45	0.90	1.40	0.19	3.5
PTHF200-40SM	200	1.12	0.70	1.10	0.32	3.0
PTHF250-40SM	250	1.05	0.70	1.10	0.36	2.5
PTHF10-30SM	10	2.56	2.20	3.40	0.05	35.0
PTHF25-30SM	25	2.16	1.40	2.10	0.07	25.0
PTHF50-30SM	50	1.81	1.20	1.30	0.10	10.0
PTHF75-30SM	75	1.62	0.80	1.20	0.13	7.0
PTHF100-30SM	100	1.50	0.60	1.00	0.15	6.0
PTHF150-30SM	150	1.33	0.60	1.00	0.19	3.5
PTHF200-30SM	200	1.04	0.50	0.70	0.30	3.0
PTHF250-30SM	250	0.96	0.50	0.70	0.36	3.0
SERIES PTKM-SM FERROUS ALLOY CORE						
PTKM10-50SM	10	7.36	1.70	3.30	0.01	35.0
PTKM25-50SM	25	5.20	1.00	1.90	0.02	10.0
PTKM50-50SM	50	3.93	0.70	1.30	0.04	7.0
PTKM75-50SM	75	3.47	0.60	1.10	0.05	5.0
PTKM100-50SM	100	3.14	0.50	0.96	0.06	4.0
PTKM150-50SM	150	2.33	0.40	0.78	0.10	3.0
PTKM200-50SM	200	1.97	0.35	0.65	0.14	2.0
PTKM250-50SM	250	1.84	0.31	0.59	0.16	1.5
PTKM330-50SM	330	1.69	0.27	0.50	0.19	1.0
PTKM10-40SM	10	4.84	1.30	2.50	0.02	35.0
PTKM25-40SM	25	3.38	0.70	1.30	0.04	20.0
PTKM50-40SM	50	1.90	0.56	1.00	0.11	13.0
PTKM75-40SM	75	1.69	0.45	0.86	0.14	9.0
PTKM100-40SM	100	1.60	0.40	0.76	0.16	6.0
PTKM150-40SM	150	1.45	0.33	0.60	0.19	3.5
PTKM200-40SM	200	1.12	0.30	0.56	0.32	3.0
PTKM250-40SM	250	1.05	0.25	0.48	0.36	2.5
PTKM10-30SM	10	2.56	0.80	1.60	0.05	35.0
PTKM25-30SM	25	2.16	0.50	0.96	0.07	25.0
PTKM50-30SM	50	1.81	0.35	0.68	0.10	10.0
PTKM75-30SM	75	1.62	0.28	0.54	0.13	7.0
PTKM100-30SM	100	1.50	0.23	0.50	0.15	6.0
PTKM150-30SM	150	1.33	0.20	0.40	0.19	3.5
PTKM200-30SM	200	1.04	0.17	0.34	0.30	3.0
PTKM250-30SM	250	0.96	0.15	0.30	0.36	3.0

*Complete part # must include series # PLUS the dash #

SERIES

**PTHFxxxR-SM & PTKMxxxR-SM
PTHF-SM & PTKM-SM**

RoHS
Compliant

Traditional
First Quality

Surface Mount Toroidal Power Chokes

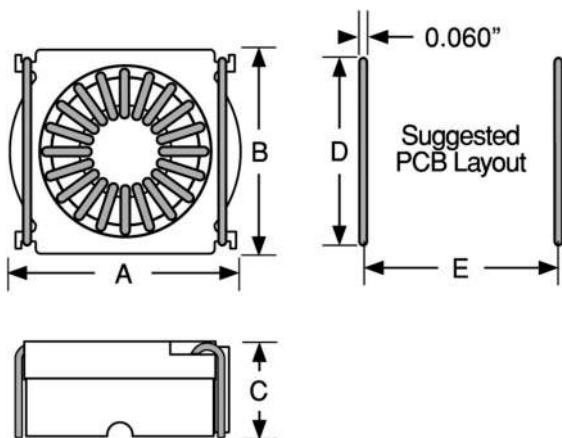

PHYSICAL PARAMETERS

PART NUMBER*	A Max.		B Max.		C Max.		D Nom.		E Nom.	
	Inches	mm	Inches	mm	Inches	mm	Inches	mm	Inches	mm
PT**10-50SM	0.700	17.78	0.670	17.02	0.400	10.16	0.600	15.24	0.600	15.24
PT**25-50SM	0.700	17.78	0.670	17.02	0.400	10.16	0.600	15.24	0.600	15.24
PT**50-50SM	0.700	17.78	0.670	17.02	0.400	10.16	0.600	15.24	0.600	15.24
PT**75-50SM	0.700	17.78	0.670	17.02	0.400	10.16	0.600	15.24	0.600	15.24
PT**100-50SM	0.700	17.78	0.670	17.02	0.400	10.16	0.600	15.24	0.600	15.24
PT**150-50SM	0.700	17.78	0.670	17.02	0.400	10.16	0.600	15.24	0.600	15.24
PT**200-50SM	0.700	17.78	0.670	17.02	0.400	10.16	0.600	15.24	0.600	15.24
PT**250-50SM	0.700	17.78	0.670	17.02	0.400	10.16	0.600	15.24	0.600	15.24
PT**330-50SM	0.700	17.78	0.670	17.02	0.400	10.16	0.600	15.24	0.600	15.24
PT**10-40SM	0.570	14.48	0.560	14.22	0.400	10.16	0.500	12.70	0.500	12.70
PT**25-40SM	0.570	14.48	0.560	14.22	0.400	10.16	0.500	12.70	0.500	12.70
PT**50-40SM	0.570	14.48	0.560	14.22	0.400	10.16	0.500	12.70	0.500	12.70
PT**75-40SM	0.570	14.48	0.560	14.22	0.400	10.16	0.500	12.70	0.500	12.70
PT**100-40SM	0.570	14.48	0.560	14.22	0.400	10.16	0.500	12.70	0.500	12.70
PT**150-40SM	0.570	14.48	0.560	14.22	0.400	10.16	0.500	12.70	0.500	12.70
PT**200-40SM	0.570	14.48	0.560	14.22	0.400	10.16	0.500	12.70	0.500	12.70
PT**250-40SM	0.570	14.48	0.560	14.22	0.400	10.16	0.500	12.70	0.500	12.70
PT**10-30SM	0.440	11.18	0.440	11.18	0.400	10.16	0.400	10.16	0.400	10.16
PT**25-30SM	0.440	11.18	0.440	11.18	0.400	10.16	0.400	10.16	0.400	10.16
PT**50-30SM	0.440	11.18	0.440	11.18	0.400	10.16	0.400	10.16	0.400	10.16
PT**75-30SM	0.440	11.18	0.440	11.18	0.400	10.16	0.400	10.16	0.400	10.16
PT**100-30SM	0.440	11.18	0.440	11.18	0.400	10.16	0.400	10.16	0.400	10.16
PT**150-30SM	0.440	11.18	0.440	11.18	0.400	10.16	0.400	10.16	0.400	10.16
PT**200-30SM	0.440	11.18	0.440	11.18	0.400	10.16	0.400	10.16	0.400	10.16
PT**250-30SM	0.440	11.18	0.440	11.18	0.400	10.16	0.400	10.16	0.400	10.16

**Insert HF or KM for complete Part Number

*Complete part # must include series # PLUS the dash #