

THIS DRAWING IS UNPUBLISHED. RELEASED FOR PUBLICATION
 © COPYRIGHT 2011 BY TE CONNECTIVITY. ALL RIGHTS RESERVED.

REVISIONS				
P	LTR	DESCRIPTION	DATE	APVD
E2		REVISED PER ECR-17-007418	5JUN17	DZ SL

NOTES:

- MATERIAL:
 HOUSING: LCP WITH 30% GF, UL94 V-0, BLACK COLOR.
 CONTACTS: PHOSPHOR BRONZE.
 PEGS: BRASS.
- FINISH:
 CONTACTS: (SEE TABLE) GOLD PLATED ON CONTACT AREA, GOLD FLASH ON SOLDER AREA, WITH ENTIRE CONTACT UNDERPLATED 1.27µm [50µ"] MIN. NICKEL.
 PEGS: 3.048µm [120µ"] MIN. MATTE-TIN OVER 1.27µm [50µ"] MIN. NICKEL.
- REFLOW SOLDER CAPABLE TO 260° PER TEC-109-201, CONDITION B.

PCI-E MINI CARD CONNECTOR SIGNAL ASSIGNMENTS
 mSATA CONNECTOR SIGNAL ASSIGNMENTS

PIN#	NAME	PIN#	NAME
51	Reserved	52	+3.3Vaux
49	Reserved	50	GND
47	Reserved	48	+1.5V
45	Reserved	46	LED_WPAN#
43	GND	44	LED_WLAN#
41	+3.3Vaux	42	LED_WWAN#
39	+3.3Vaux	40	GND
37	GND	38	USB_D+
35	GND	36	USB_D-
33	PETp0	34	GND
31	PETn0	32	SMB_DATA
29	GND	30	SMB_CLK
27	GND	28	+1.5V
25	PERp0	26	GND
23	PERn0	24	+3.3Vaux
21	GND	22	PERST#
19	Reserved* (UIM_C4)	20	W_DISABLE#
17	Reserved* (UIM_C8)	18	GND

MECHANICAL KEY	
15	GND
13	REFCLK+
11	REFCLK-
9	GND
7	CLKREQ#
5	COEX2
3	COEX1
1	WAKE#

PIN#	NAME	PIN#	NAME
51	Presence Detection	52	+3.3V
49	DA/DSS	50	GND
47	Vendor	48	+1.5V
45	Vendor	46	Reserved
43	No Connect	44	Reserved
41	+3.3V	42	Reserved
39	+3.3V	40	GND
37	GND	38	Reserved
35	GND	36	Reserved
33	+A	34	GND
31	-A	32	Two Wire Interface
29	GND	30	Two Wire Interface
27	GND	28	+1.5V
25	-B	26	GND
23	+B	24	+3.3V
21	GND	22	Reserved
19	Reserved	20	Reserved
17	Reserved	18	GND

MECHANICAL KEY	
15	GND
13	Reserved
11	Reserved
9	GND
7	Reserved
5	Reserved
3	Reserved
1	Reserved

* Reserved for future UIM interface (if needed)

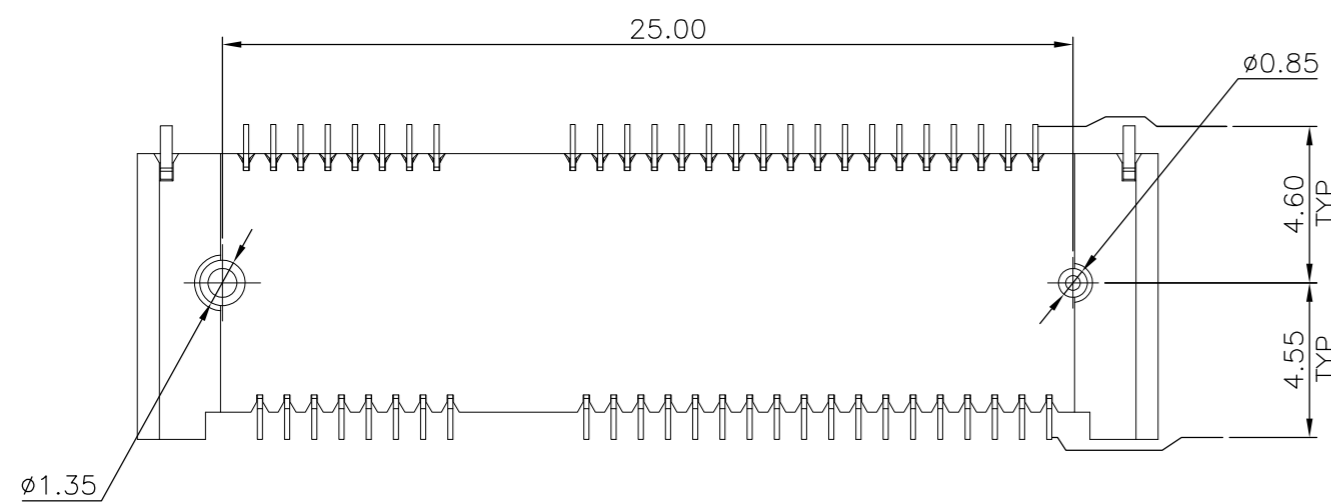
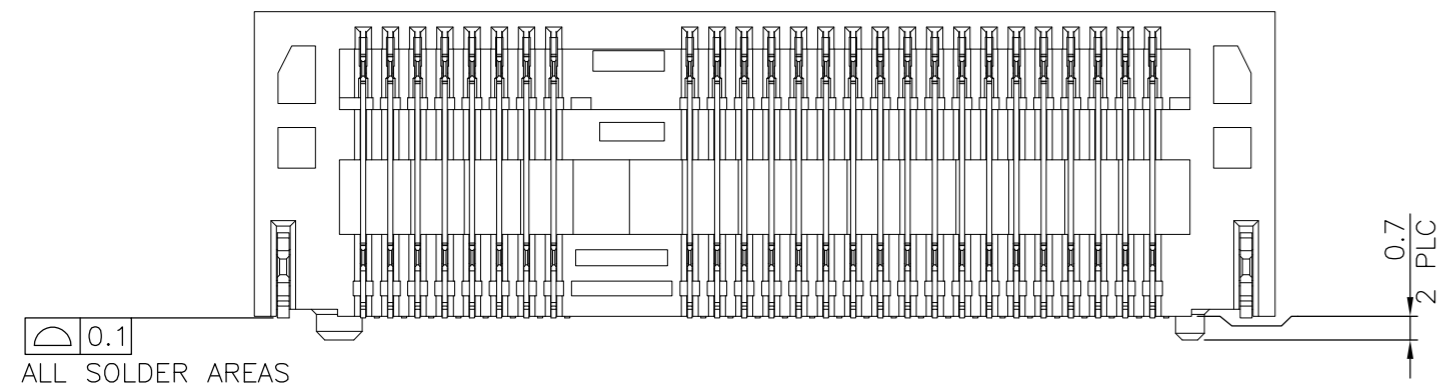
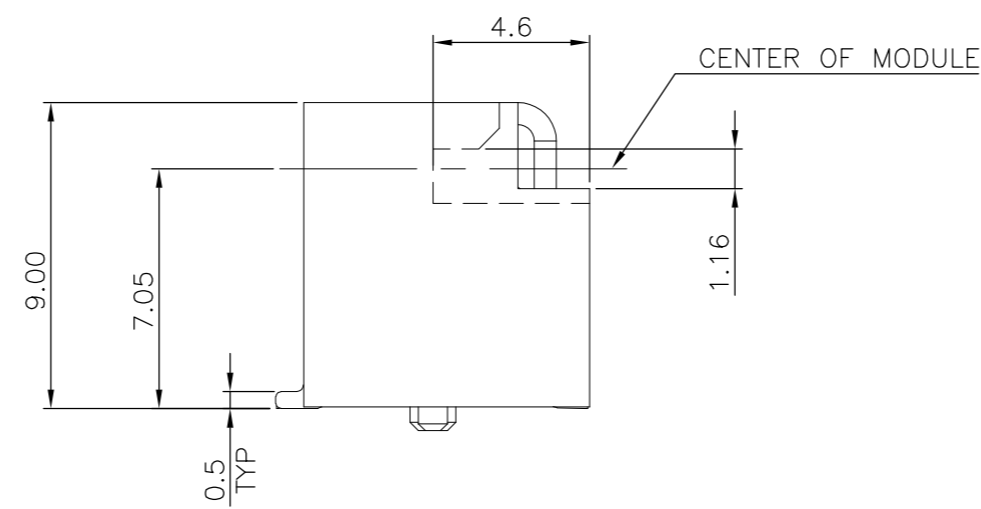
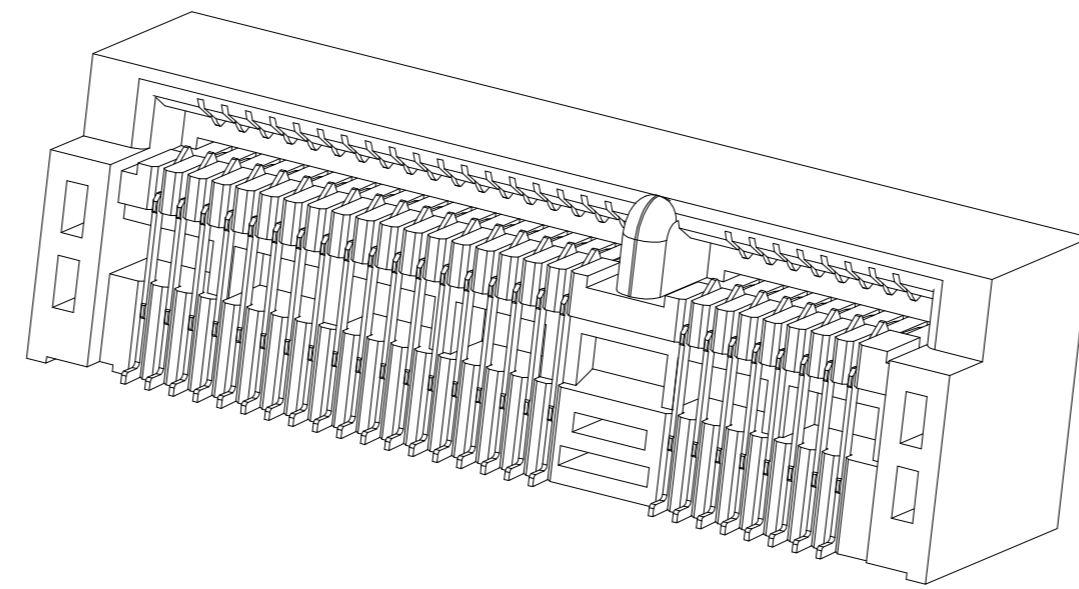
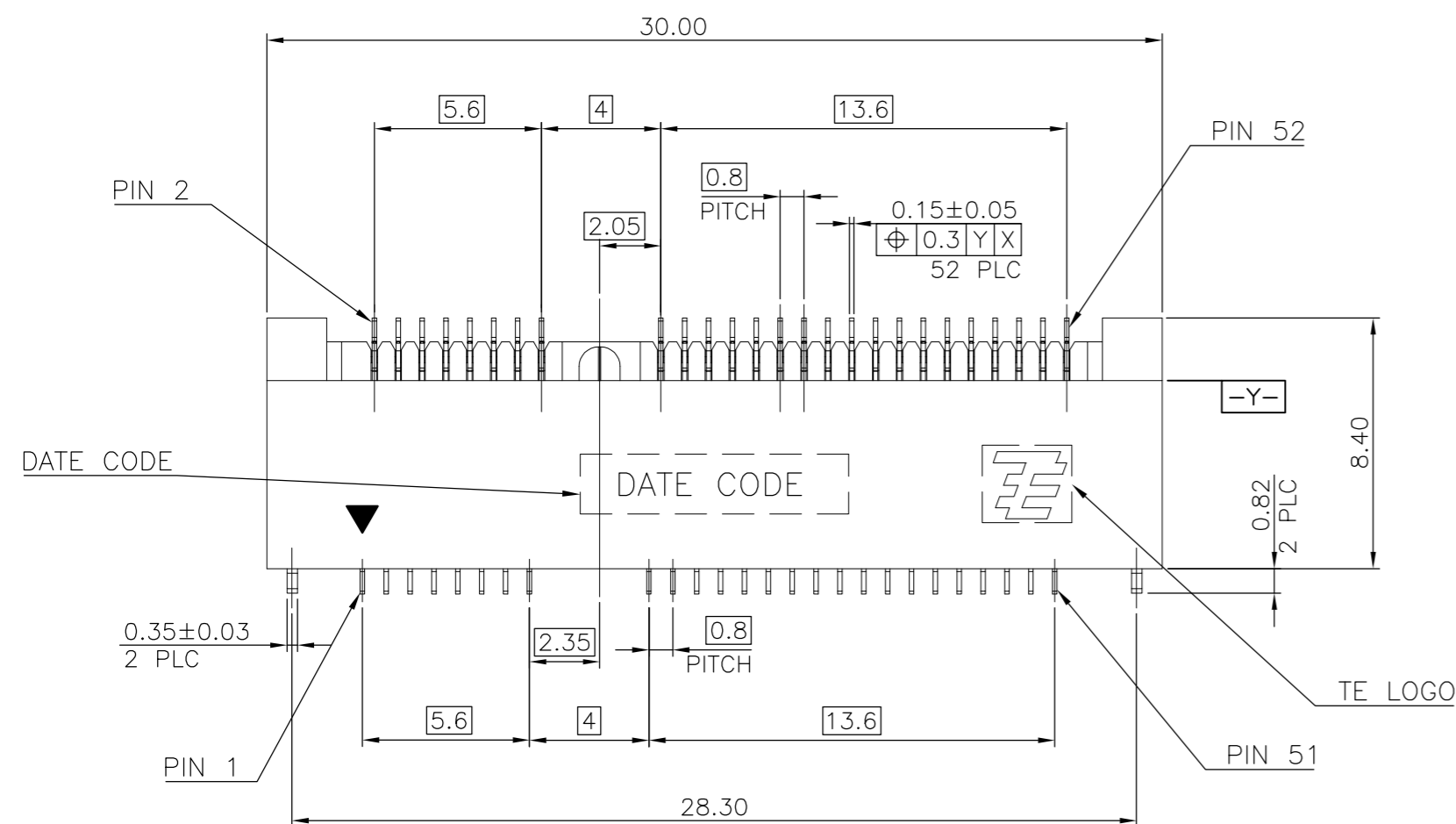
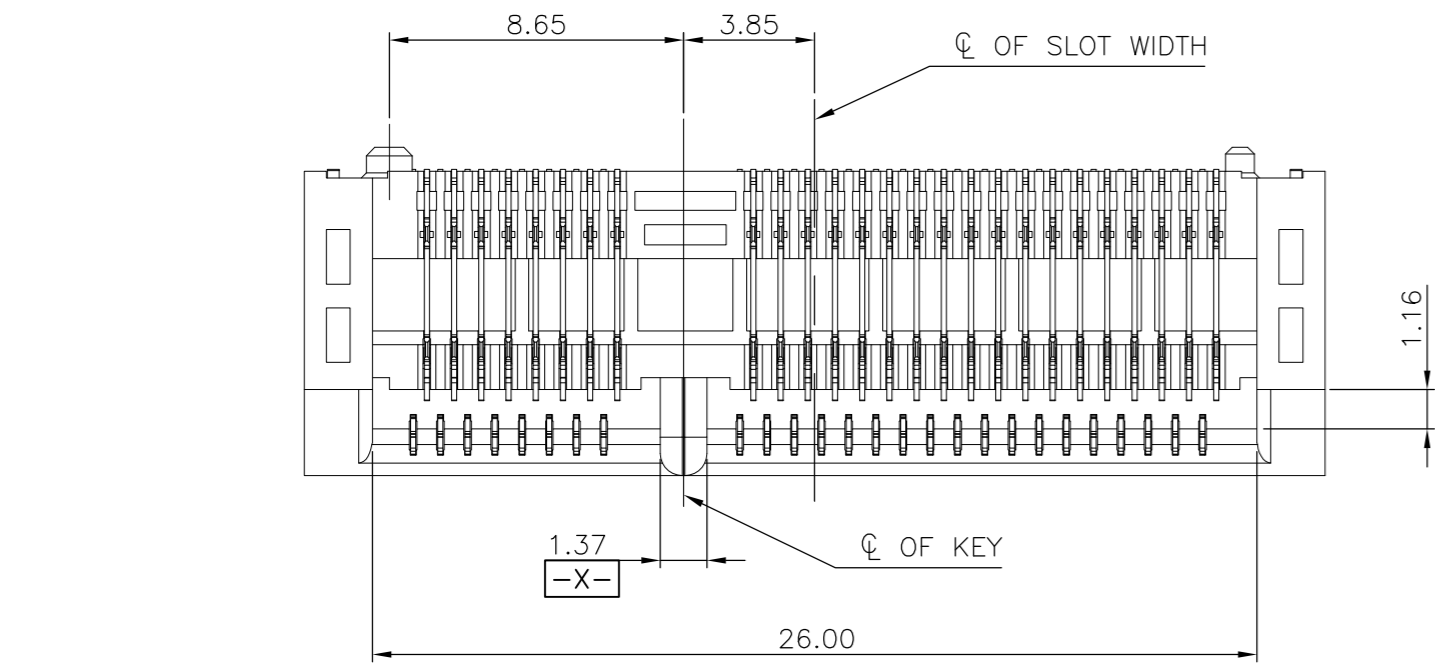

THIS DRAWING IS A CONTROLLED DOCUMENT.		DWN A. WU 27JAN2011	GOLD FLASH 1759513-1	
DIMENSIONS: mm		CHK S. CHIEN 27JAN2011	MIN. GOLD THICKNESS PART NUMBER	
TOLERANCES UNLESS OTHERWISE SPECIFIED: 0 PLC ± - 1 PLC ± 0.3 2 PLC ± 0.2 3 PLC ± - 4 PLC ± - ANGLES ± 3°		APVD W. KODAMA 27JAN2011	TE Connectivity	
MATERIAL SEE NOTE		FINISH SEE NOTE	NAME 2 IN 1 mSATA & PCI EXPRESS MINI CARD CONNECTOR, 9 MM HEIGHT	
WEIGHT 2.28 g		SIZE A2	CAGE CODE 00779	DRAWING NO. C=1759513
CUSTOMER DRAWING		RESTRICTED TO -		SCALE -
		SHEET 1 of 5		REV E2

THIS DRAWING IS UNPUBLISHED. RELEASED FOR PUBLICATION
 © COPYRIGHT 2011 BY TE CONNECTIVITY. ALL RIGHTS RESERVED.

REVISIONS					
P	LTR	DESCRIPTION	DATE	DWN	APVD
		SEE SHEET 1	-	-	-

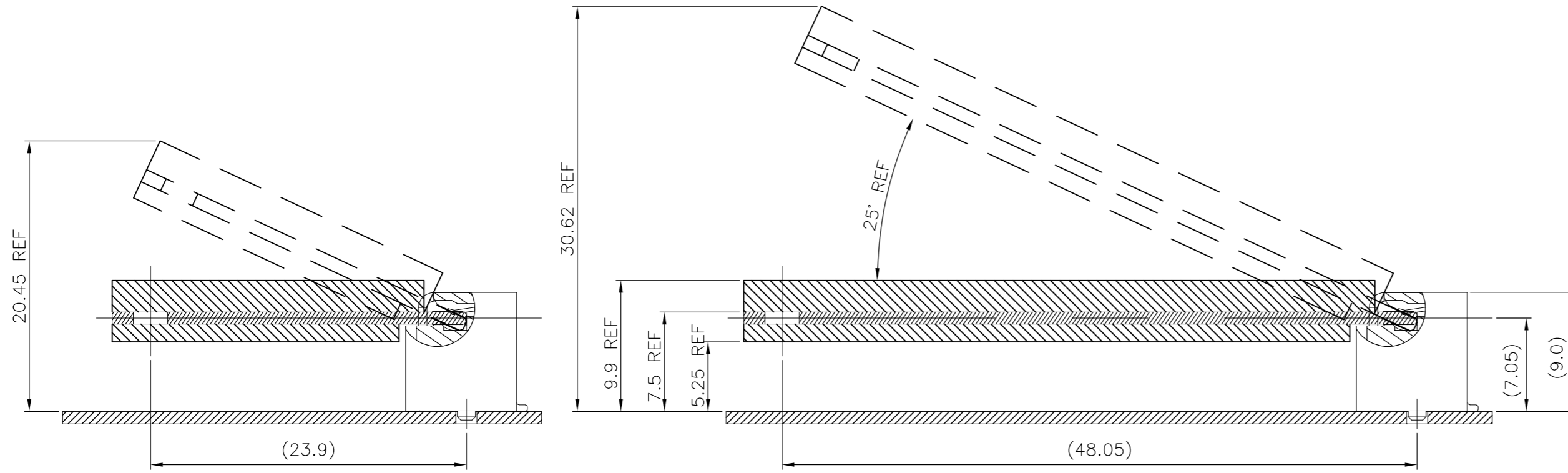

EJECT HEIGHT FOR HALF CARD

EJECT HEIGHT FOR FULL CARD

COMPONENT KEEP OUT AREA FOR CARD HOLD DOWN SOLUTION

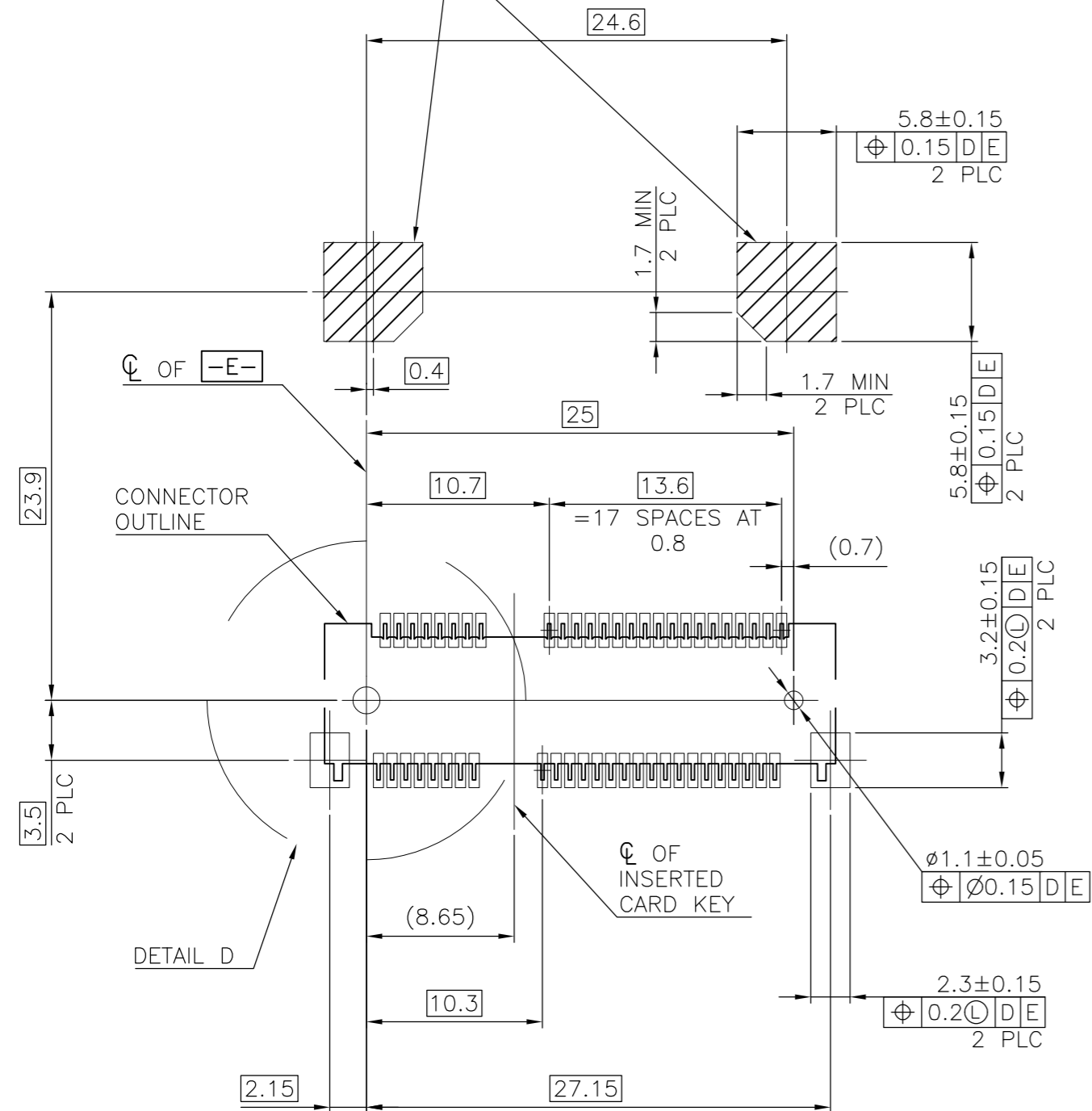

-D- IS THE TOP SURFACE OF PCB.
 RECOMMENDED P.C. BOARD PATTERN LAYOUT FOR HALF CARD CONNECTOR (TOP VIEW)

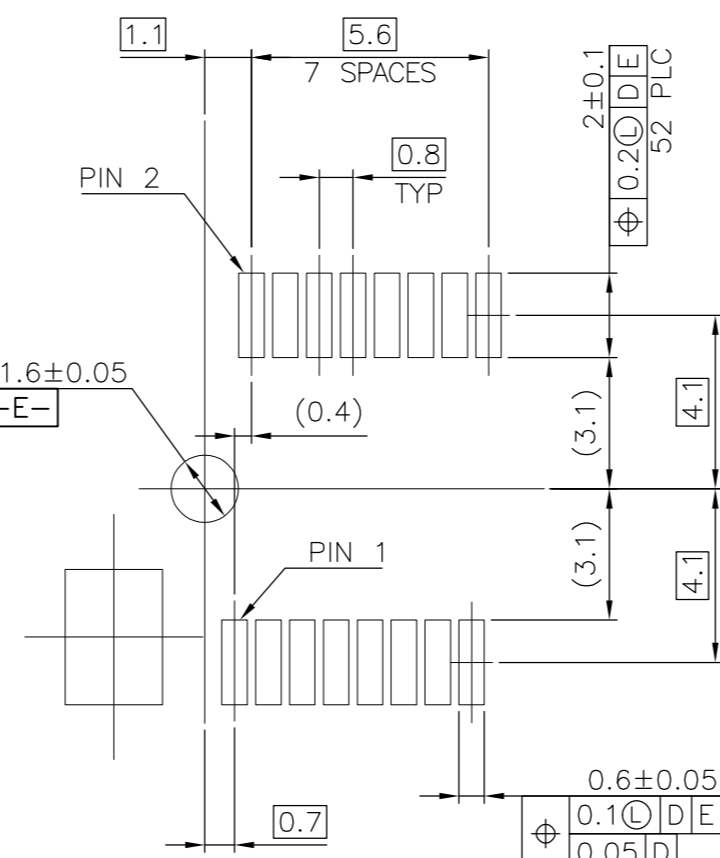

DETAIL D SCALE 2:1

COMPONENT KEEP OUT AREA FOR CARD HOLD DOWN SOLUTION

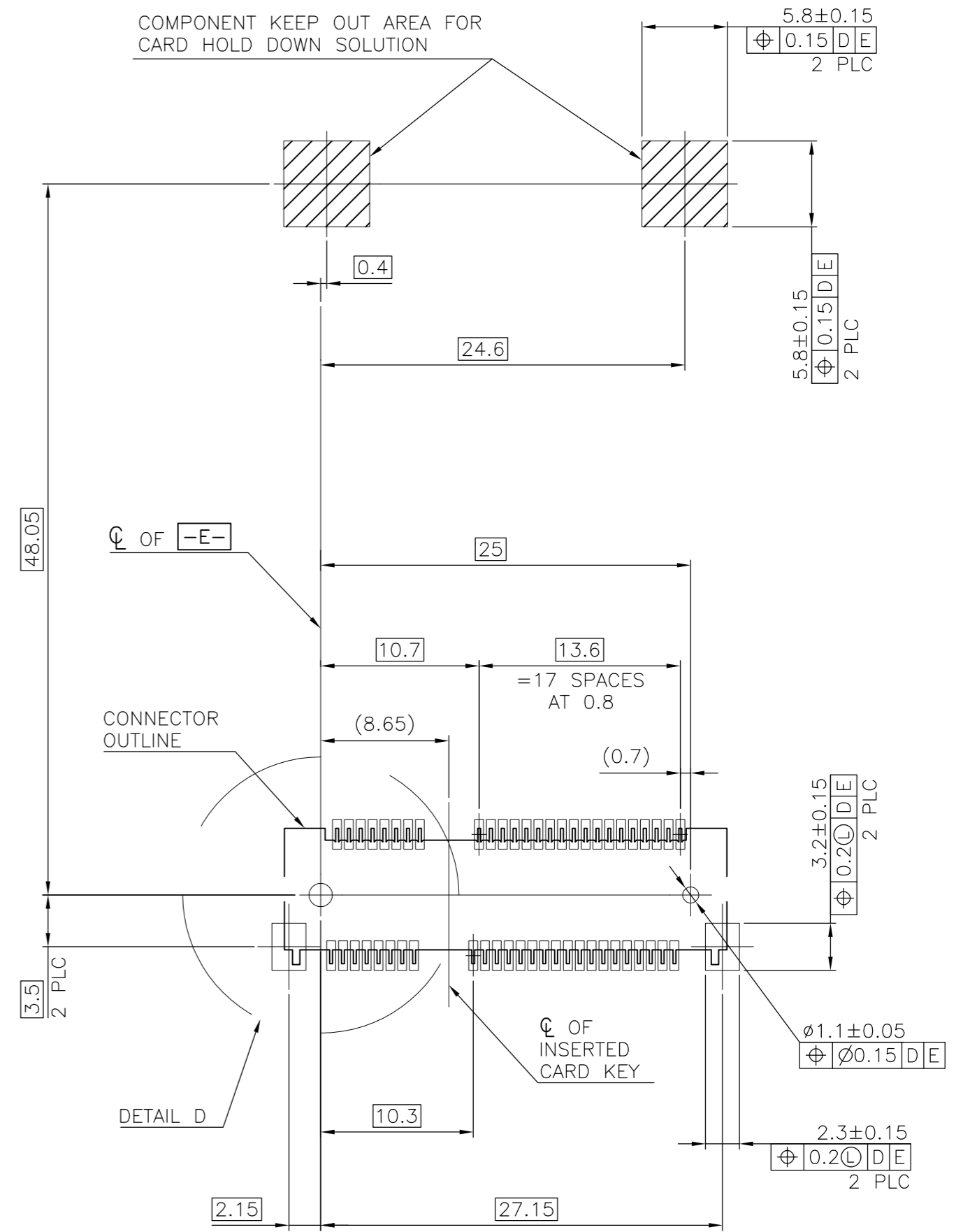

-D- IS THE TOP SURFACE OF PCB.
 RECOMMENDED P.C. BOARD PATTERN LAYOUT FOR FULL CARD CONNECTOR (TOP VIEW)

THIS DRAWING IS A CONTROLLED DOCUMENT.		DWN	TE Connectivity		
DIMENSIONS: mm		CHK	2 IN 1 mSATA & PCI EXPRESS MINI CARD CONNECTOR, 9 MM HEIGHT		
TOLERANCES UNLESS OTHERWISE SPECIFIED		APVD	NAME	SIZE	CAGE CODE
0 PLC	±	PRODUCT SPEC		A2	00779
1 PLC	±	APPLICATION SPEC	DRAWING NO	C=1759513	
2 PLC	±		RESTRICTED TO	-	
3 PLC	±		SCALE	SHEET	2 of 5
4 PLC	±		CUSTOMER DRAWING	REV	E2
ANGLES	±				
FINISH					

THIS DRAWING IS UNPUBLISHED. RELEASED FOR PUBLICATION
 © COPYRIGHT 2011 BY TE CONNECTIVITY. ALL RIGHTS RESERVED.

REVISIONS					
P	LTR	DESCRIPTION	DATE	DWN	APVD
		SEE SHEET 1	-	-	-

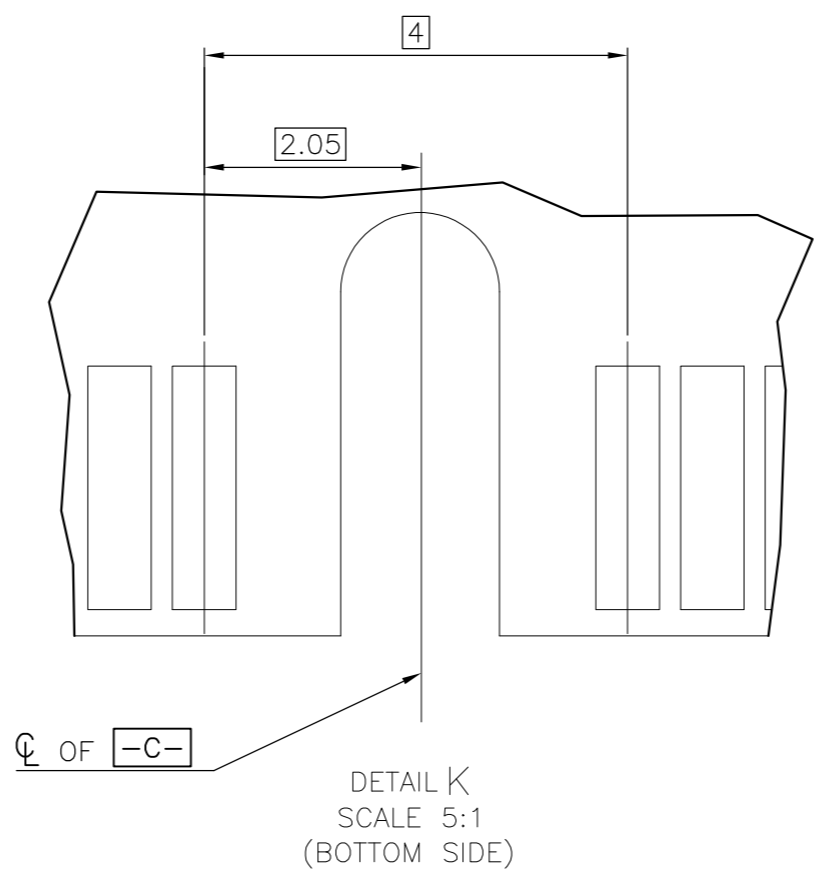
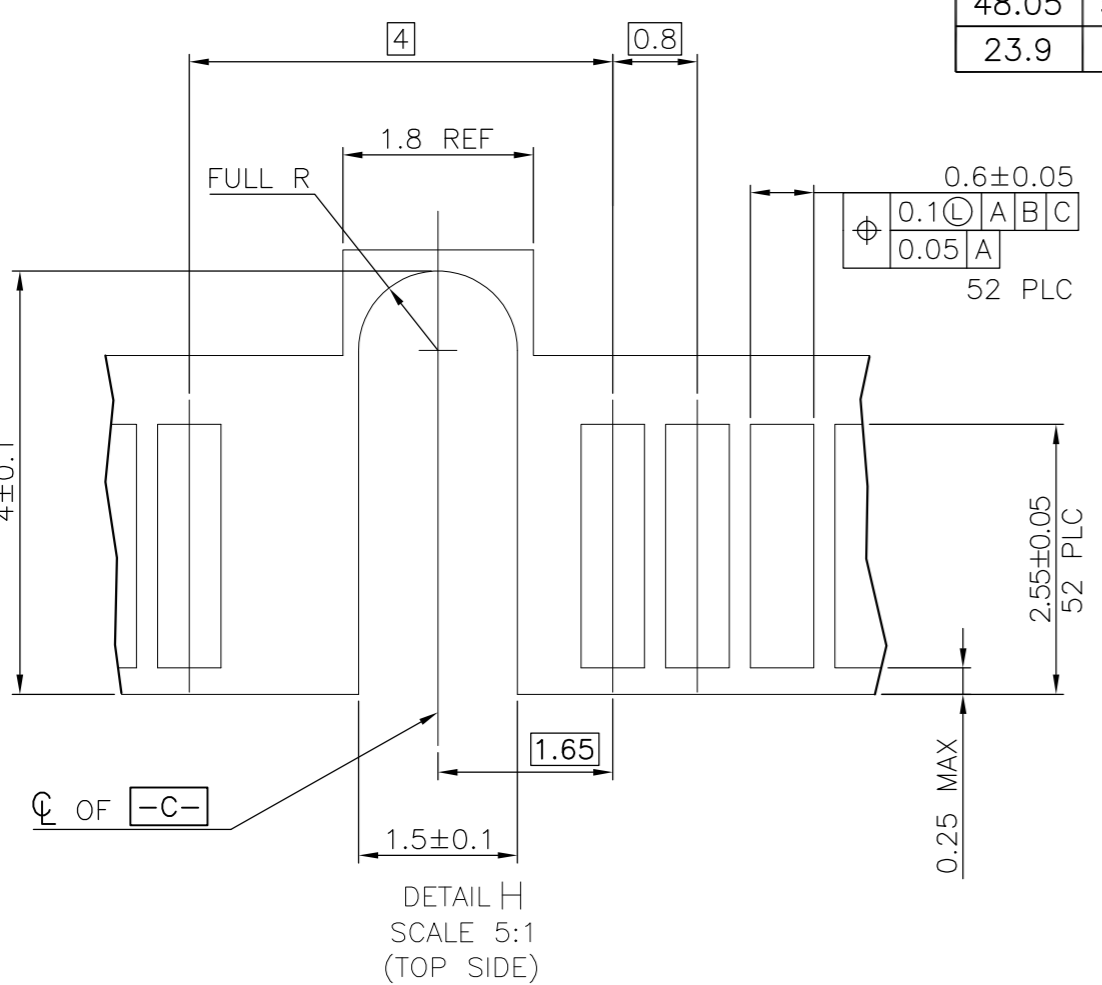
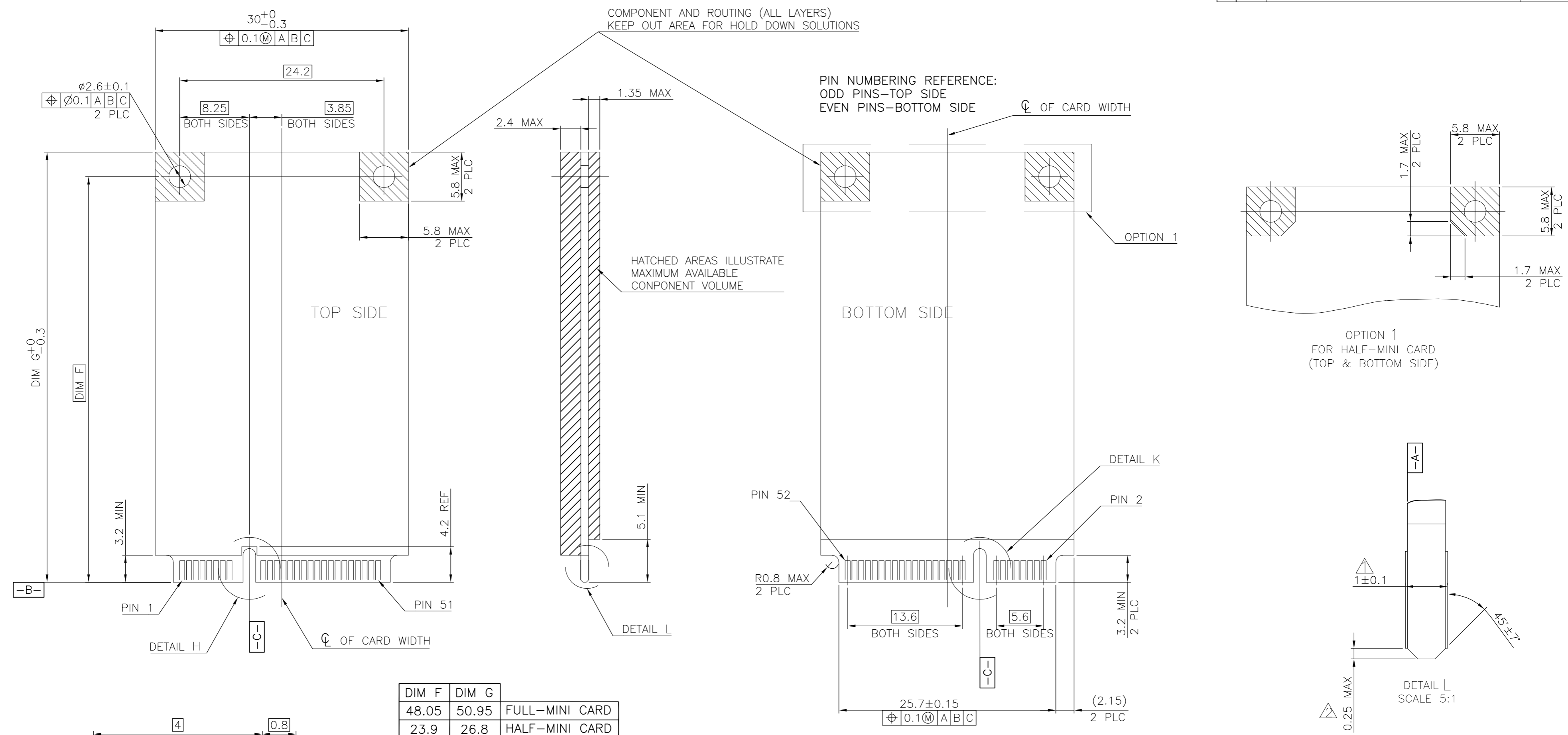

- NOTES:
- ▲ CARD THICKNESS APPLIES ACROSS TABS AND INCLUDES PLATING AND/OR METALLIZATION.
 - ▲ EDGE BEVEL MUST BE PRESENT AND FREE OF CUTTING BURRS FROM PCB AND CONTACT MATERIALS.

FOR PCI EXPRESS MINI CARD

THIS DRAWING IS A CONTROLLED DOCUMENT.		DWN	TE Connectivity		
DIMENSIONS: mm		CHK	NAME		
TOLERANCES UNLESS OTHERWISE SPECIFIED:		APVD	2 IN 1 mSATA & PCI EXPRESS MINI CARD CONNECTOR, 9 MM HEIGHT		
0 PLC	±	PRODUCT SPEC	SIZE	CAGE CODE	DRAWING NO
1 PLC	±	APPLICATION SPEC	A2	00779	C=1759513
2 PLC	±		WEIGHT	SCALE	SHEET
3 PLC	±			-	3 OF 5
4 PLC	±		CUSTOMER DRAWING	REV	E2
ANGLES	±				

THIS DRAWING IS UNPUBLISHED. RELEASED FOR PUBLICATION
 © COPYRIGHT 2011 BY TE CONNECTIVITY. ALL RIGHTS RESERVED.

REVISIONS				
P	LTR	DESCRIPTION	DATE	APVD
		SEE SHEET 1	-	-

COMPONENT AND ROUTING (ALL LAYERS)
 KEEP OUT AREA FOR HOLD DOWN SOLUTIONS

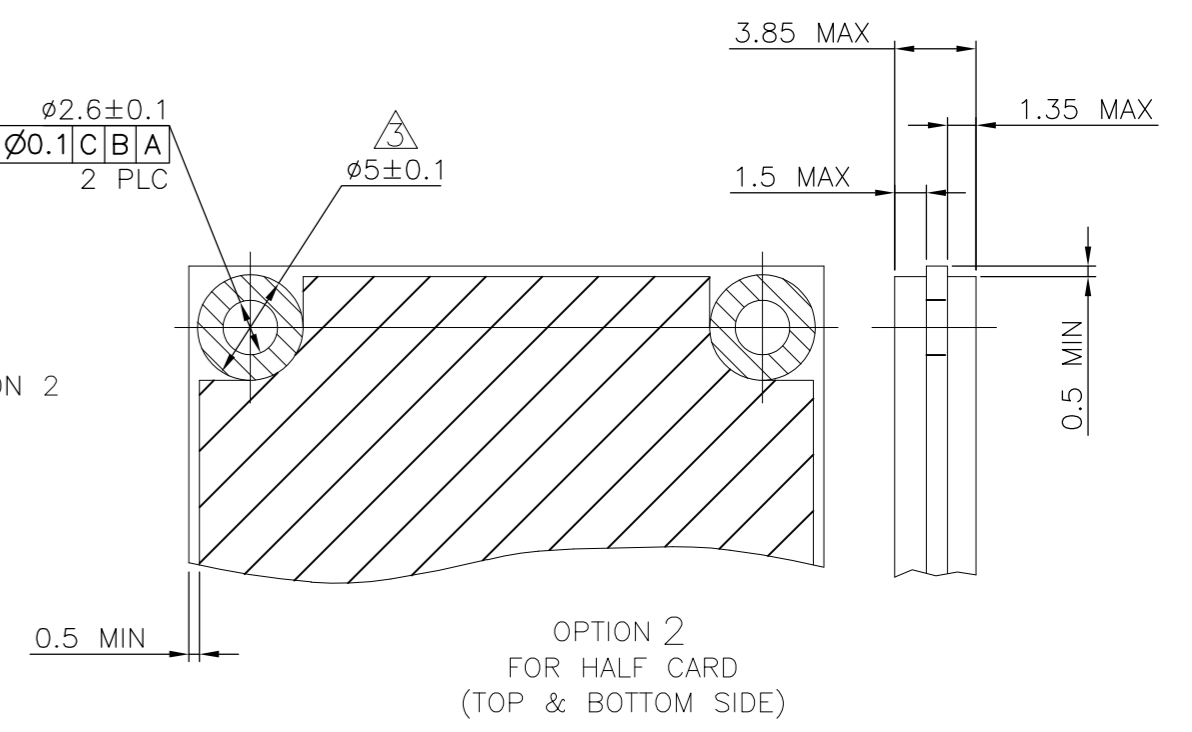
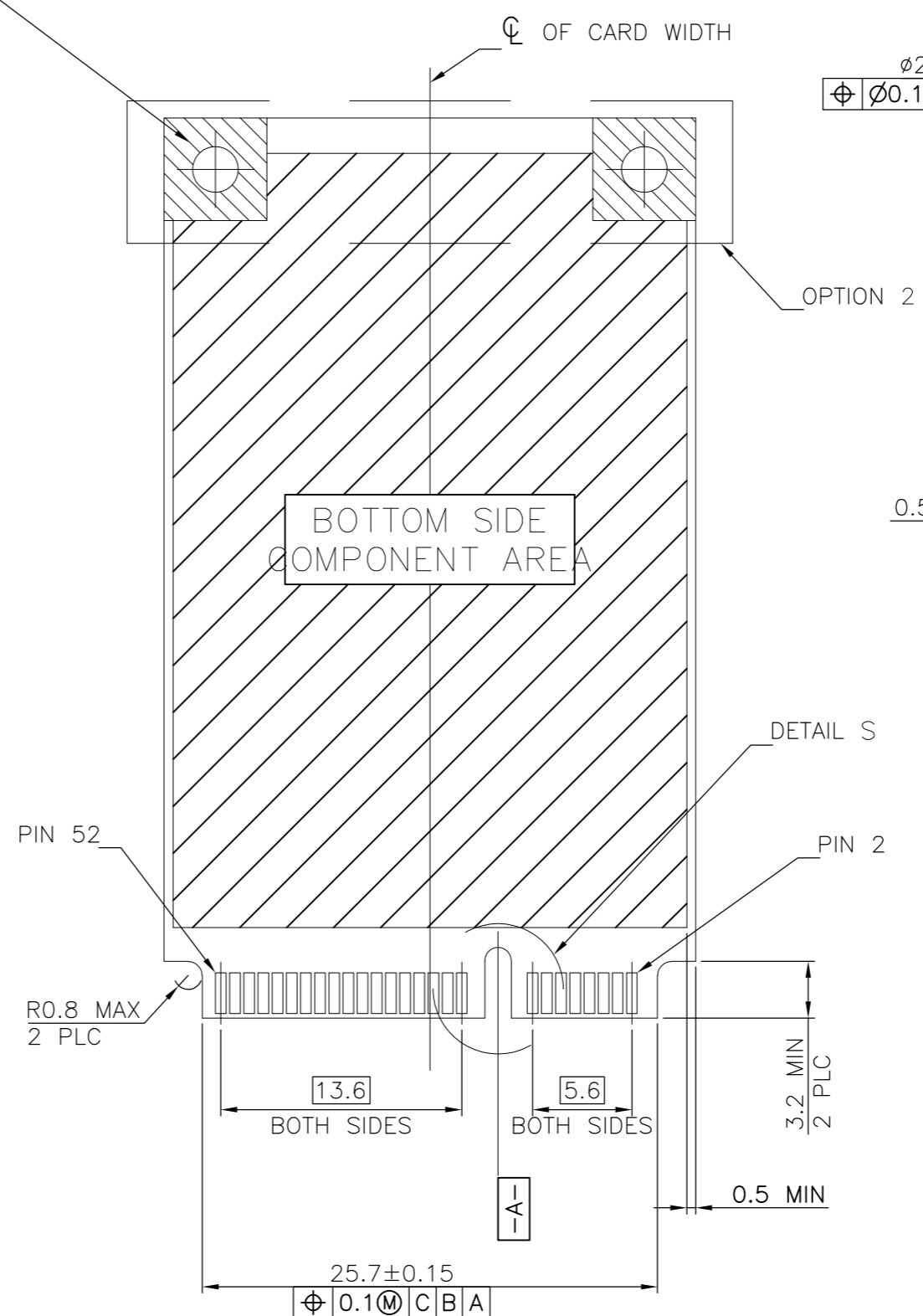
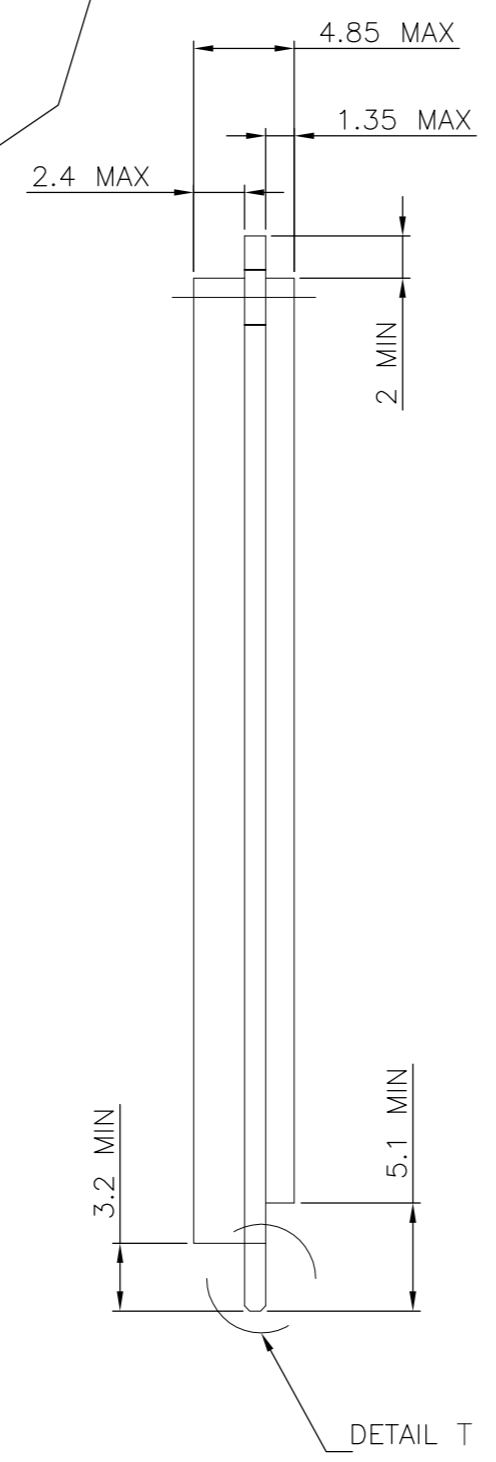
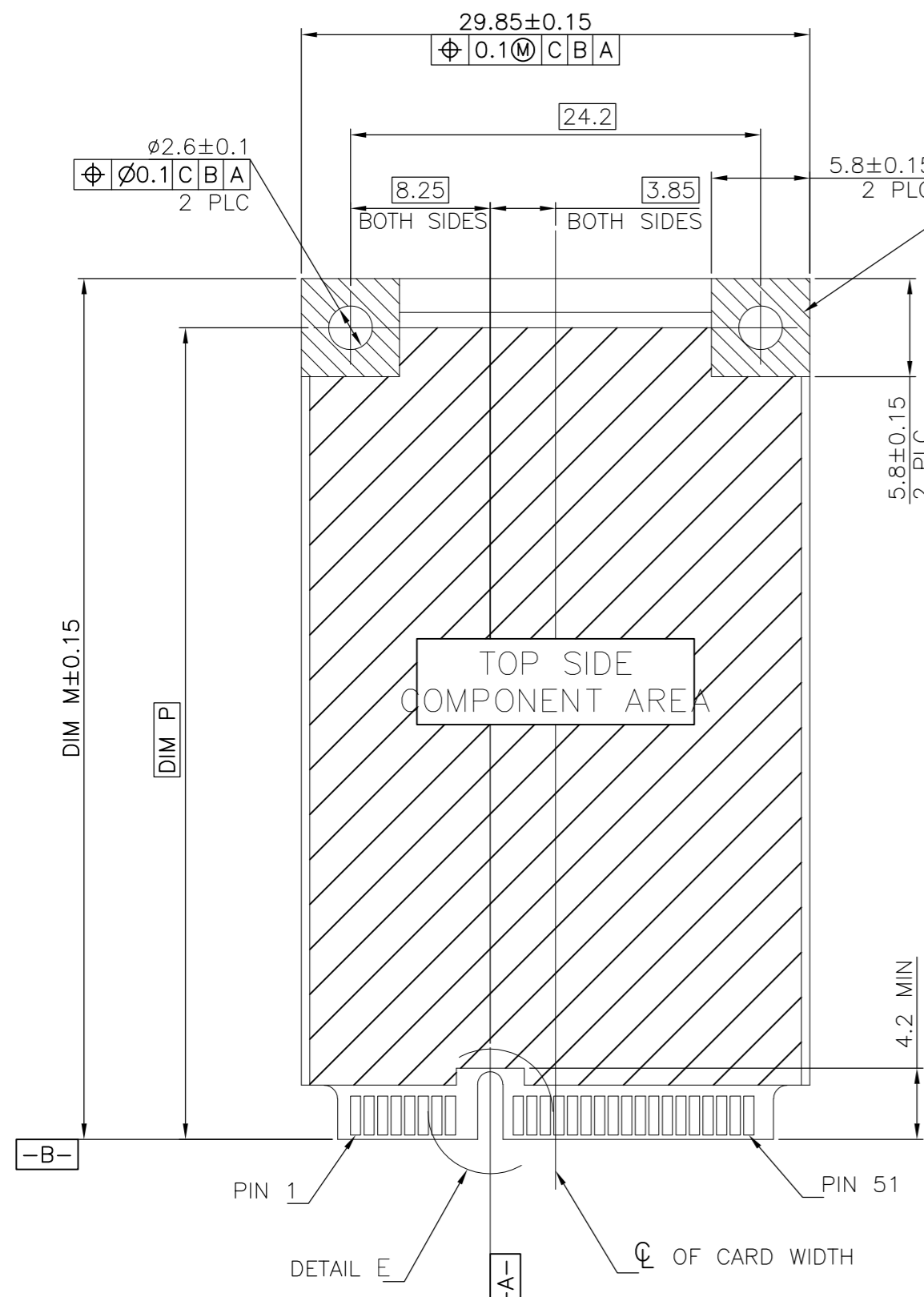

DIM P	DIM M	
48.05	50.8	FULL CARD
23.9	26.8	HALF CARD

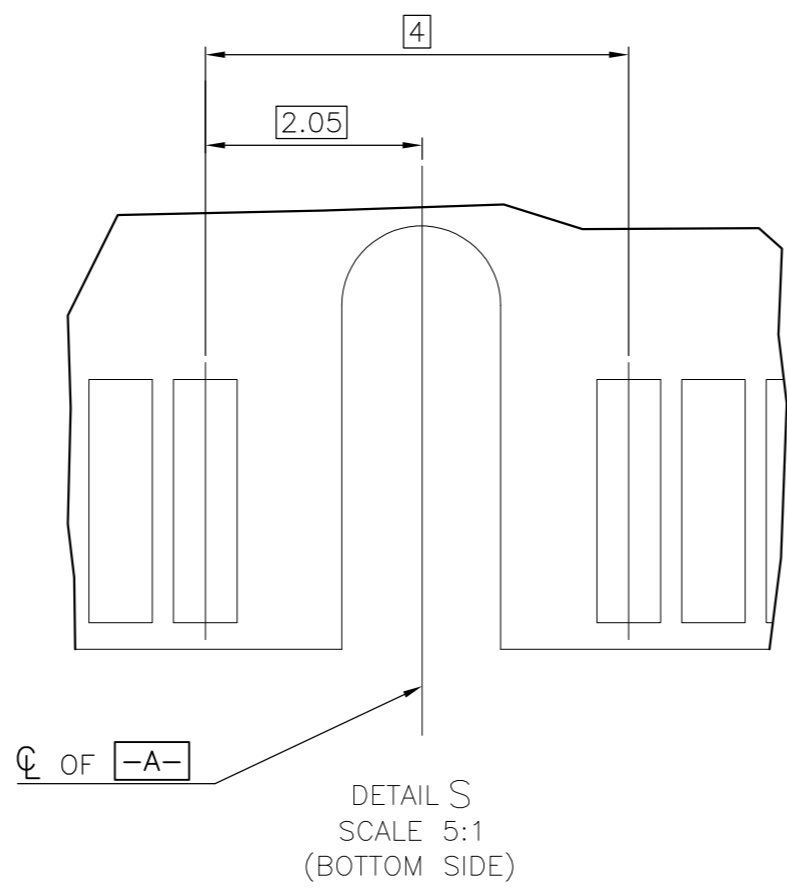
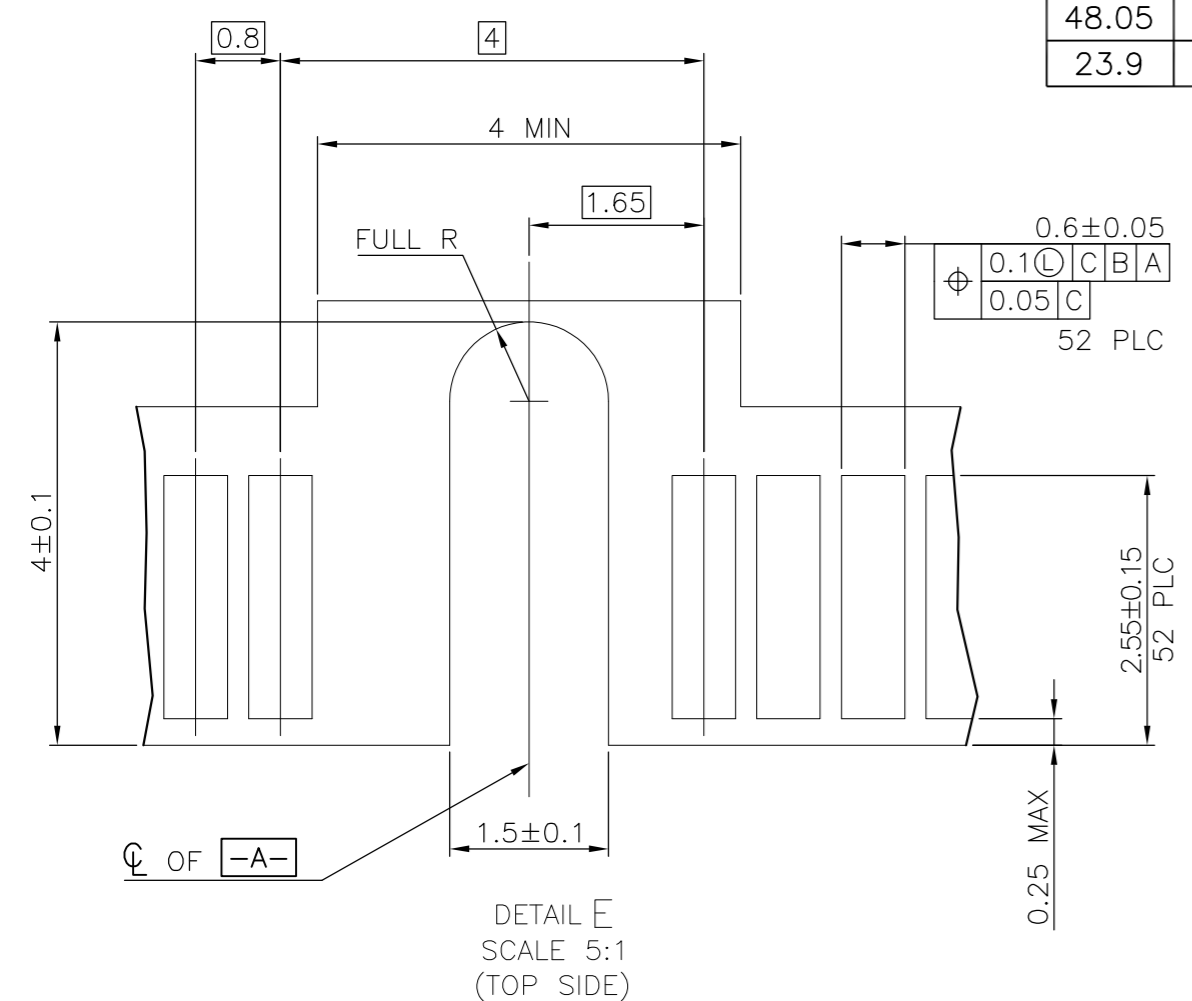

- NOTES:
- △ CARD THICKNESS APPLIES ACROSS TABS AND INCLUDES PLATING AND/OR METALLIZATION.
 - △ EDGE BEVEL MUST BE PRESENT AND FREE OF CUTTING BURRS FROM PCB AND CONTACT MATERIALS.
 - △ COMPONENT AND ROUTING (TOP/BOTTOM LAYER) KEEP OUT AREA FOR HOLD DOWN SOLUTIONS.

FOR mSATA

THIS DRAWING IS A CONTROLLED DOCUMENT.		DWN	TE Connectivity	
DIMENSIONS: mm		CHK	NAME	
TOLERANCES UNLESS OTHERWISE SPECIFIED		APVD	2 IN 1 mSATA & PCI EXPRESS MINI CARD CONNECTOR, 9 MM HEIGHT	
0 PLC	±	PRODUCT SPEC	SIZE	CAGE CODE
1 PLC	±	APPLICATION SPEC	A2	00779
2 PLC	±		DRAWING NO	C=1759513
3 PLC	±		RESTRICTED TO	
4 PLC	±			
ANGLES	±			
FINISH	±			
MATERIAL		WEIGHT	CUSTOMER DRAWING	
			SCALE	SHEET 4 OF 5
				REV E2

THIS DRAWING IS UNPUBLISHED. RELEASED FOR PUBLICATION
 © COPYRIGHT 2011 BY TE CONNECTIVITY. ALL RIGHTS RESERVED.

REVISIONS				
P	LTR	DESCRIPTION	DATE	APVD
		SEE SHEET 1	-	-

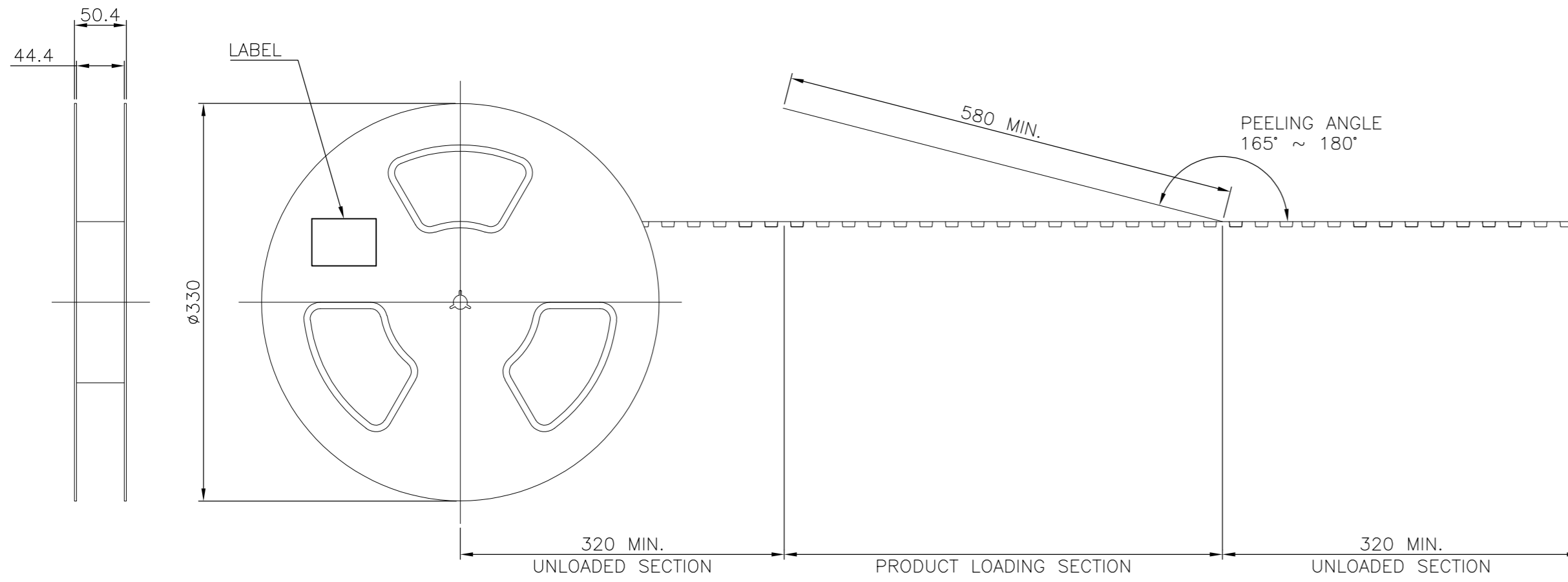

NOTES:

- MATERIAL:
 BOX: FIBREBOARD, CORRUGATED, DOUBLE WALL.
 COVER TAPE: POLYSTYRENES, TRANSPARENT.
 CARRIER TAPE: POLYSTYRENES, TRANSPARENT.
 REEL: HIPS, BLUE COLOR.
 BAG: POLYETHYLENES, TRANSPARENT.
- EACH BAG SHALL BE INCLUDED DESICCANT.
- PEELING STRENGTH: 0.1 ~ 1.3 N (10 ~ 130 GRAMS).
- PEELING SPEED: 300 mm/min.

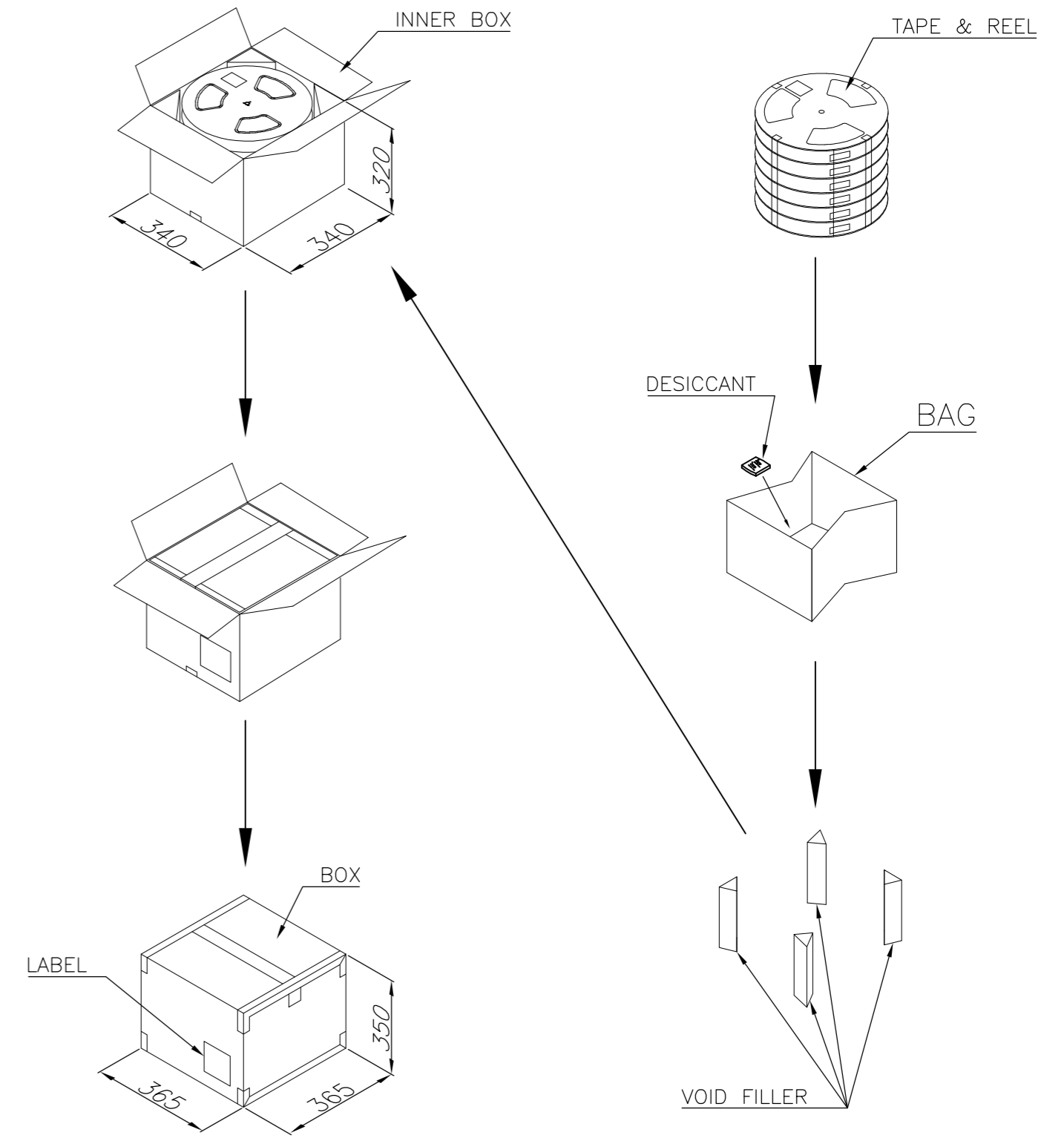

USER DIRECTION OF UNREELING

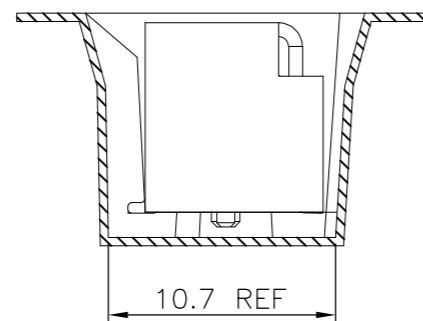
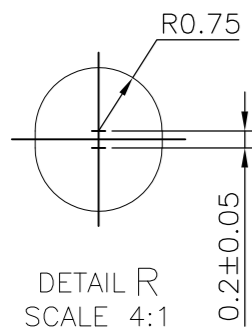
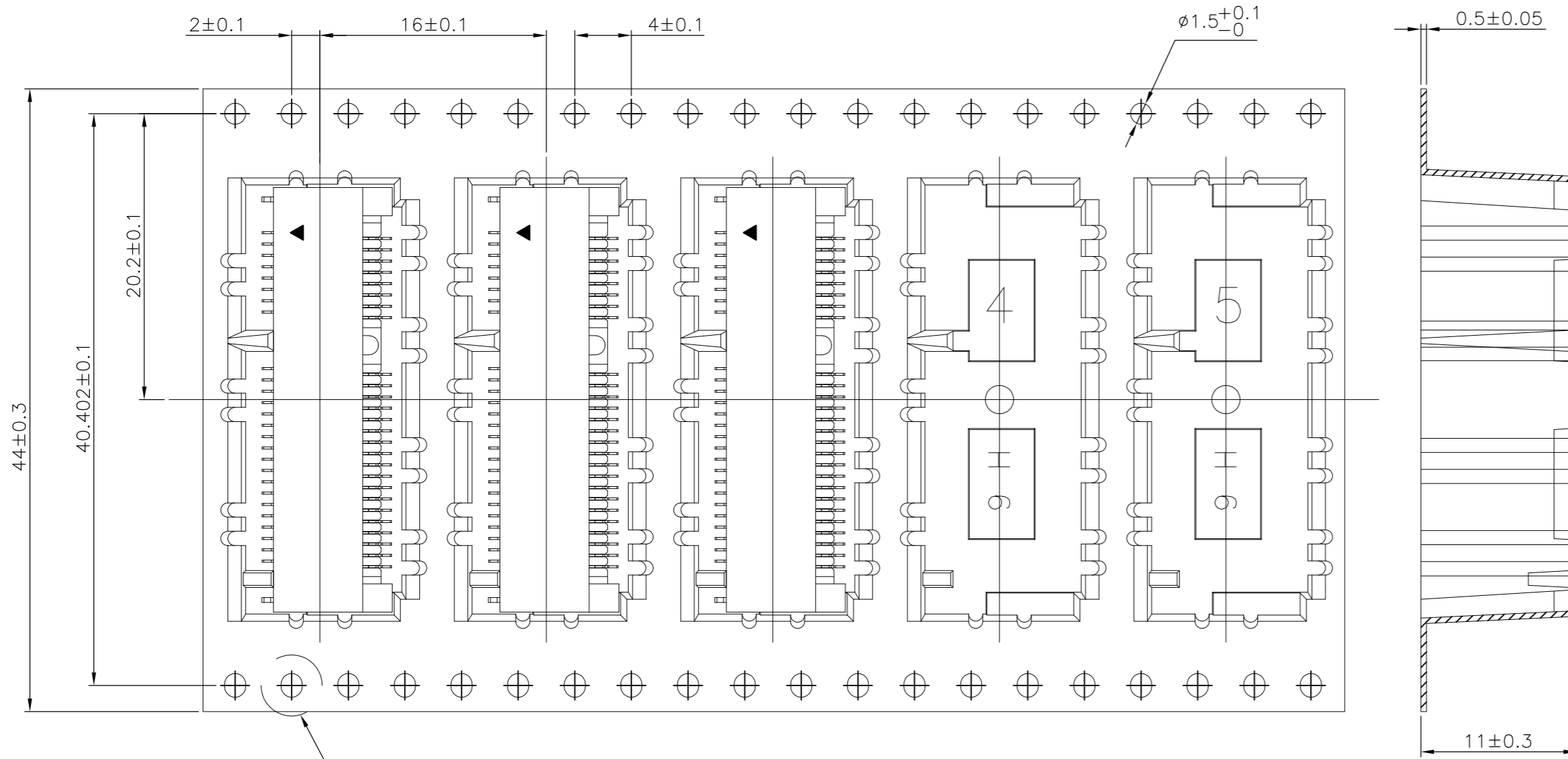

2100	6	350	6.1 Kg	11.1 Kg
PCS/BOX	REELS/BOX	PCS/TAPE	NET WEIGHT	GROSS WEIGHT

THIS DRAWING IS A CONTROLLED DOCUMENT.		DWN	-	
DIMENSIONS: mm		CHK	-	
TOLERANCES UNLESS OTHERWISE SPECIFIED		APVD	-	
0 PLC ±		PRODUCT SPEC	-	
1 PLC ±		APPLICATION SPEC	-	
2 PLC ±		WEIGHT	-	
3 PLC ±		CUSTOMER DRAWING	-	
4 PLC ±		SCALE	-	
4 PLC ANGLES ±		SHEET	5 of 5	
FINISH		REV	E2	

NAME		TE Connectivity		
2 IN 1 mSATA & PCI EXPRESS MINI CARD CONNECTOR, 9 MM HEIGHT				
SIZE	CAGE CODE	DRAWING NO	RESTRICTED TO	
A2	00779	C=1759513	-	