

PRODUCT NO

SEE TABLE

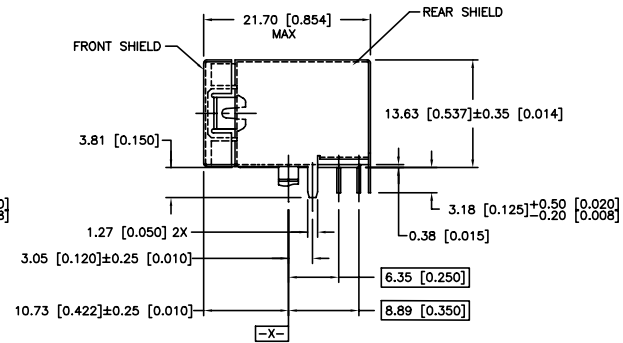
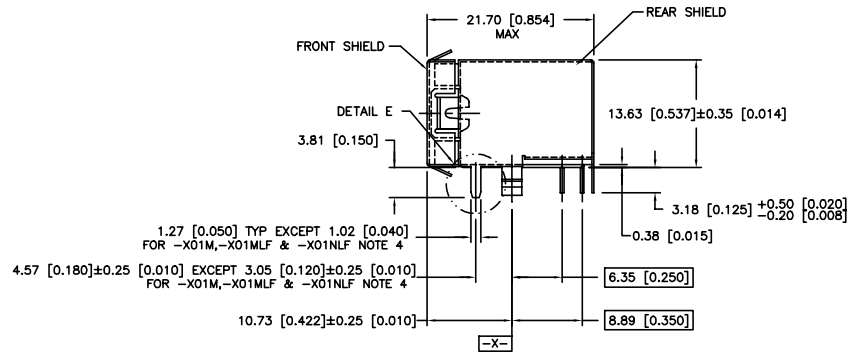

VIEW A-A

NOTE 5

NOTES:

1. RECOMMENDED P.C.B. THICKNESS 1.60 [0.063].
2. CONTACTS: PHOS BRONZE ALLOY UNS-C51000, ϕ 0.460 [0.0181] ROUND WIRE, PLATING SEE TABLE.
- ③ SHIELDING MAT'L: .25 [0.010] THICK BRASS ALLOY.
SHIELDING PLATING: FOR 94910-XXXM: 2.54 μ m/100 μ " MIN BRIGHT TIN-LEAD PLATED OVER 0.76 μ m/30 μ " MIN NICKEL UNDERPLATING PER BUS-15-002/M.
LEAD FREE OPTION:
FOR 94910-XXXNLF: 0.76 μ m/30 μ " MIN NICKEL PLATING, WITH SELECTIVE TIN ON SOLDER TAILS, SEE DETAIL E.
SHIELDING PLATING: FOR 94910-XXXMLF: 2.54 μ m/100 μ " MIN BRIGHT PURE TIN PLATED OVER 0.76 μ m/30 μ " MIN NICKEL UNDERPLATING PER BUS-15-002/M.
- ④ SPECIALLY FOR ONE-PORT P/N 94910-X01M, -X01MLF & 94910-X01NLF ONLY. SOLDER TAIL OF SHIELD IS 1.02 [0.040] WIDE, DISTANCE FROM PCB PEG TO THE SOLDER TAIL IS 3.05 [0.120].
- ⑤ SPECIALLY FOR ONE-PORT P/N 94910-X01AM, -X01AMLF & 94910-X01ANLF ONLY. SOLDER TAIL OF SHIELD IS 1.27 [0.050] WIDE, DISTANCE FROM PCB PEG TO THE SOLDER TAIL IS 3.05 [0.120].
6. ALL DIMENSIONS IN MILLIMETERS/INCHES.
- ⑦ CENTER PEG FOR 8-PORTS AND ABOVE, (-XXXM, -XXXMLF PRODUCT ONLY).
- ⑧ NO CENTER PEG AVAILABLE ON -XXXNLF PRODUCT.
- ⑨ 'LF' SUFFIX AT THE END OF PART NUMBER IS LEAD FREE.
10. THE HOUSING WILL WITHSTAND EXPOSURE TO 260°C PEAK TEMPERATURE FOR 15 SECONDS IN A WAVE SOLDER APPLICATION WITH A 1.5mm MINIMUM THICK CIRCUIT BOARD. SEE APPLICATION NOTES/PROCEDURES IF THEY ARE AVAILABLE.
11. THIS PRODUCT MEETS EUROPEAN UNION DIRECTIVES AND OTHER COUNTRY REGULATION AS DESCRIBED IN GS-22-008
- ⑫ PLATING OPTIONS:
MAY BE EITHER GOLD OR GXT PLATED AT MANUFACTURER'S OPTION.

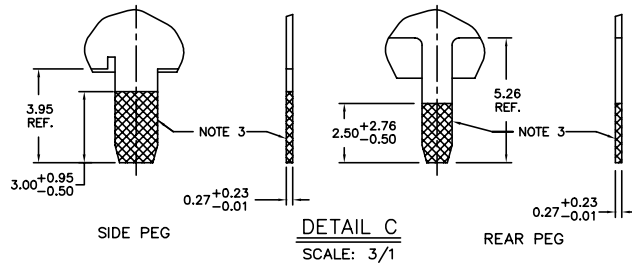
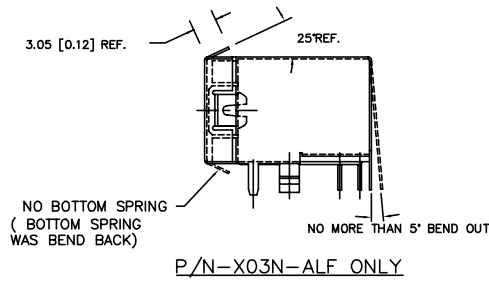

mat'l. code		surface	tolerance	projection	product family
l t r e c n n o d r		ISO1302	ISO1101 ISO406	ϕ \square	MOD JACK
date		tolerances unless otherwise specified		mm	R/A 8 POS GANG JACK ASSY SHIELDED, SNAP PEG
R	M05-0067 MHT	angle	0.X±0.3	scale 1.0	
S	N08-0001 SH	0°±2'	0.XX±0.15		
T	N08-0100 SH		0.XXX±0.05		
U	N08-0239 SH	11/10/08	dr	KCHOU	3/18/93
V	ELX-N-010997 SH	MMO	3/14/12	enr	TC
				chr	J.TSAO
				appd	J.TSAO
sheet	revision				
index	sheet				





PRODUCT No.	No. OF PORTS	DIM A +0.60 [0.024] -0	DIM B	DIM C±0.10 [0.004]	DIM D±0.15 [0.006]	GROUND LEG NO. ON THE BACK (VIEW B)	NOTE
94910-X01M	1	15.74 [0.620]	-----	5.72 [0.225]	11.43 [0.450]	NONE	NOTE 4
94910-X01AM	1	15.74 [0.620]	-----	5.72 [0.225]	11.43 [0.450]	NONE	NOTE 5
94910-X04M	4	58.92 [2.320]	41.91 [1.650]	26.67 [1.050]	53.34 [2.100]	3	
94910-X08M	8	114.80 [4.520]	97.79 [3.850]	54.61 [2.150]	109.22 [4.300]	3	
94910-X01MLF	1	15.74 [0.620]	-----	5.72 [0.225]	11.43 [0.450]	NONE	NOTE 4
94910-X01AMLF	1	15.74 [0.620]	-----	5.72 [0.225]	11.43 [0.450]	NONE	NOTE 5
94910-X04MLF	4	58.92 [2.320]	41.91 [1.650]	26.67 [1.050]	53.34 [2.100]	3	
94910-X08MLF	8	114.80 [4.520]	97.79 [3.850]	54.61 [2.150]	109.22 [4.300]	3	
94910-X11MLF	1	15.74 [0.620]	-----	5.72 [0.225]	11.43 [0.450]	NONE	NOTE 4
94910-X11AMLF	1	15.74 [0.620]	-----	5.72 [0.225]	11.43 [0.450]	NONE	NOTE 5
94910-X14MLF	4	58.92 [2.320]	41.91 [1.650]	26.67 [1.050]	53.34 [2.100]	3	
94910-X18MLF	8	114.80 [4.520]	97.79 [3.850]	54.61 [2.150]	109.22 [4.300]	3	

0: MEETS WAVE SOLDER PROCESS PRODUCT NO.
1: MEETS PIP PROCESS PRODUCT NO.

PLATING CODE X	PLATING (12)
0	5u" Au + high performance lubricant
1	.38uM/15u" GOLD
3	5u" Au + high performance lubricant
5	1.27uM/50u" GOLD

mat'l. code		surface ISO1302 ✓		tolerance ISO1101 ISO406		projection 		product family MOD JACK	
ltr	ecr	no	dr	date		tolerances unless otherwise specified		title	
R	M05-0067	MHT		4/8/05	angle	0.X±0.3	mm	R/A 8 POS GANG JACK ASSY	
S	N08-0001	SH		1/3/07	radius	0.XX±0.15		SHIELDED, SNAP PEG	
T	N08-0100	SH		09/25/08	0'±2'	0.XXX±0.05	scale 1.0		
U	N08-0239	SH		11/10/08	dr	KCHOU	3/18/93	dwg no sheet 3 of 6 size	
V	ELX-N-010997	SH	MMO	3/14/12	enr	TC	3/18/93	94910 A4	
					chr	J.TSAO	3/18/93	type Product Customer Drawing	
					appd	J.TSAO	3/18/93		
sheet	revision								
index	sheet								

PRODUCT No.	PORTS	DIM A ₋₀	DIM B±0.20 [0.008]	DIM C±0.10 [0.004]	DIM D±0.15 [0.006]	THE BACK (VIEW B)	
94910-X01NLF	1	15.74 [0.620]	-----	5.72 [0.225]	11.43 [0.450]	NONE	NOTE 4
94910-X01ANLF	1	15.74 [0.620]	-----	5.72 [0.225]	11.43 [0.450]	NONE	NOTE 5
94910-X04NLF	4	58.92 [2.320]	41.91 [1.650]	26.67 [1.050]	53.34 [2.100]	3	
94910-X08NLF	8	114.80 [4.520]	97.79 [3.850]	54.61 [2.150]	109.22 [4.300]	3	
94910-X11NLF	1	15.74 [0.620]	-----	5.72 [0.225]	11.43 [0.450]	NONE	NOTE 4
94910-X11ANLF	1	15.74 [0.620]	-----	5.72 [0.225]	11.43 [0.450]	NONE	NOTE 5
94910-X14NLF	4	58.92 [2.320]	41.91 [1.650]	26.67 [1.050]	53.34 [2.100]	3	
94910-X18NLF	8	114.80 [4.520]	97.79 [3.850]	54.61 [2.150]	109.22 [4.300]	3	

0: MEETS WAVE SOLDER PROCESS PRODUCT NO.
 1: MEETS PIP PROCESS PRODUCT NO.

PLATING CODE X	PLATING ⑫
0	.76uM/30u" G.X.T.
1	.38uM/15u" GOLD
3	5u" Au + high performance lubricant
5	1.27uM/50u" GOLD

mat'l. code		surface <input checked="" type="checkbox"/> ISO1302		tolerance <input checked="" type="checkbox"/> ISO1101 ISO406		projection		product family MOD JACK	
l tr ecn nodr		date		tolerances unless otherwise specified		mm		title	
R	M05-0067	MHT	4/8/05	angle	0.X±0.3	← mm →		R/A 8 POS GANG JACK ASSY	
S	N08-0001	SH	1/3/07	0°±2'	0.XX±0.15	scale 1.0		SHIELDED, SNAP PEG	
T	N08-0100	SH	09/25/08		0.XXX±0.05				
U	N08-0239	SH	11/10/08	dir	KCHOU	3/18/93		dwg no	
V	ELX-N-010997	SH	MMO	3/14/12	enr	TC	3/18/93		sheet 4 of 6
				chr		J.TSAO	3/18/93		size A4
				appd		J.TSAO	3/18/93		type Product Customer Drawing
sheet	revision								
index	sheet								



PRODUCT NO.
SEE TABLE

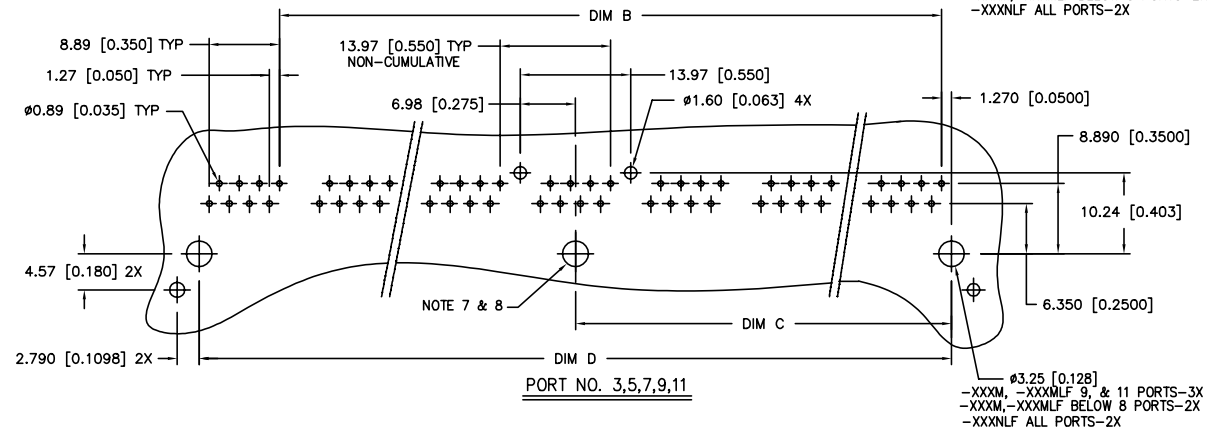
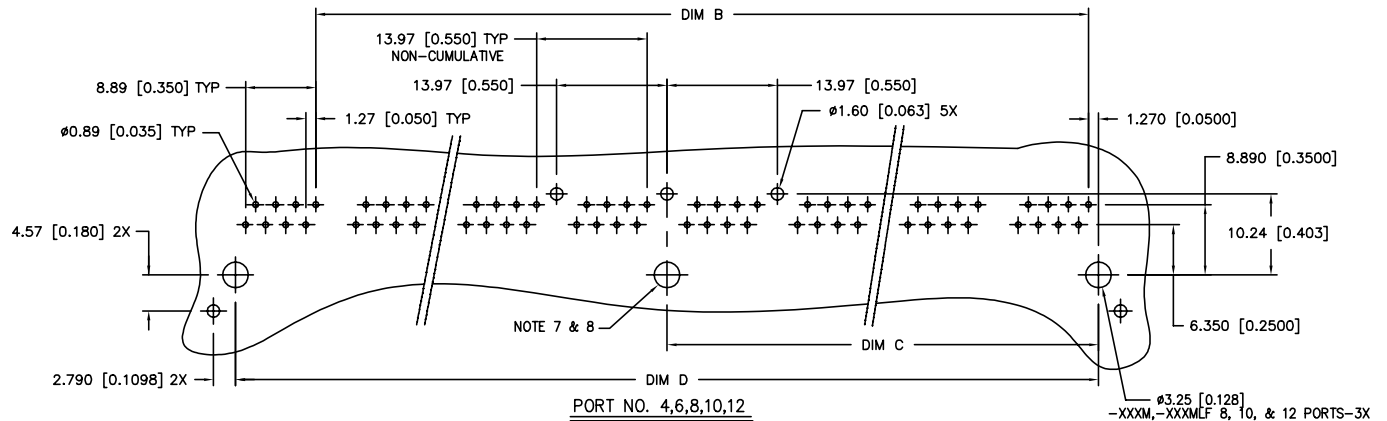
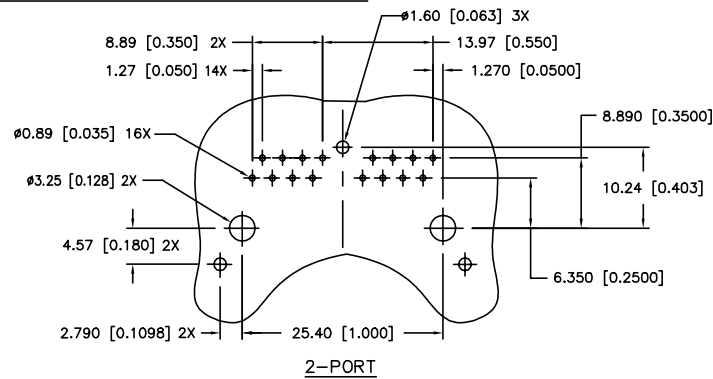
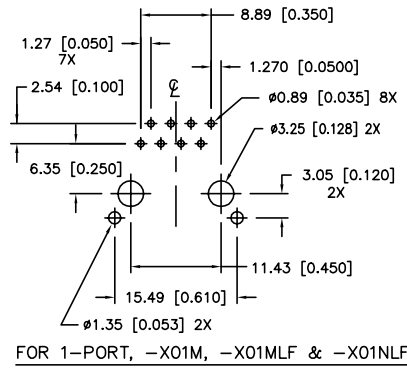
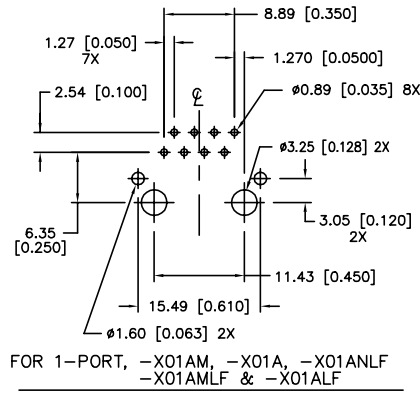

RECOMMENDED P.C.B LAYOUT

mat'l. code		surface ISO1302 ✓		tolerance ISO1101 ISO406		projection mm		product family MOD JACK		
l trechn nodr date		tolerances unless other		wise specified		title				
R	M05-0067	MHT	4/8/05	0.1	0.2	R/A 8 POS GANG JACK ASSY				
S	N08-0001	SH	1/3/07	0.1	0.2	SHIELDED, SNAP PEG				
T	N08-0100	SH	09/25/08	0.1	0.2	scale 1.0				
U	N08-0239	SH	11/10/08	chr	KCHOU	3/18/93	dwg no		sheet 5 of 6	size
V	ELX-N-010997	SH	3/14/12	engr	TC	3/18/93	94910		A4	
sheet		revision		chr		J.TSAO	3/18/93	type Product Customer Drawing		
index		sheet		appd		J.TSAO	3/18/93			

LATCHING AND GROUNDING TAB LOCATING CONFIGURATION

- INDICATES LATCHING TAB (SEE SHEET 1)
 - INDICATES GROUNDING TAB ON THE FRONT OF PRODUCT (SEE SHEET 1)
 - ▨ INDICATES GROUNDING LEG ON THE BACK OF PRODUCT (VIEW B)
- OBSOLETE

PORT NUMBERS

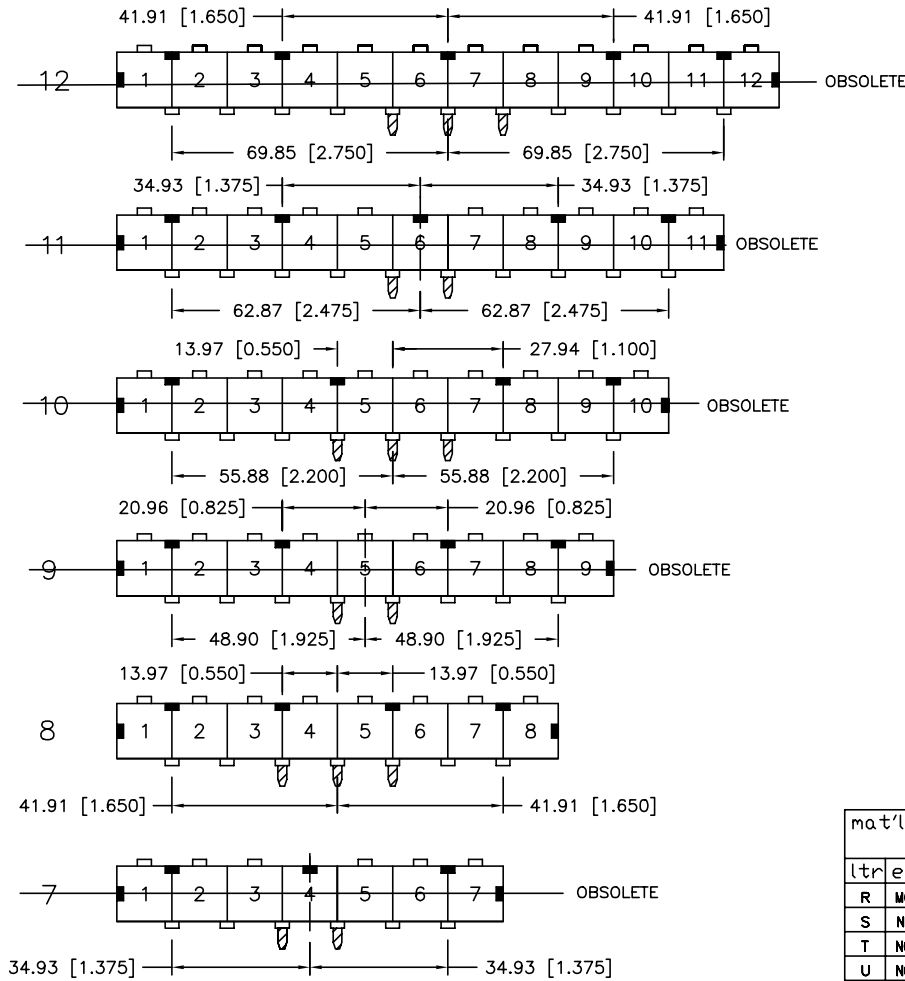

PORT NUMBERS

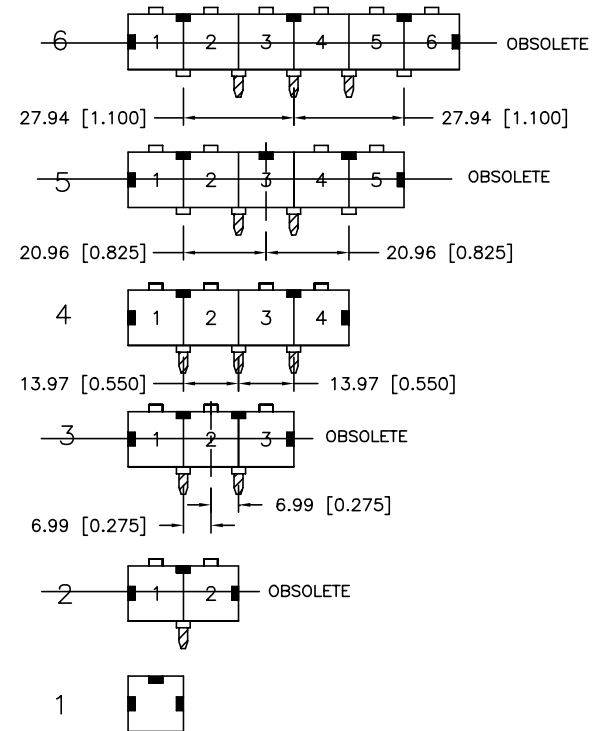

mat'l. code		surface ISO1302 ✓		tolerance ISO1101 ISO406		projection mm		product family MOD JACK		
ltr ecn nodr		date		tolerances unless otherwise specified		mm		title		
R	M05-0067	MHT	4/8/05	angle	0.X±0.3	scale 1.0		R/A 8 POS GANG JACK ASSY		
S	N08-0001	SH	1/3/07	0°±2'	0.XX±0.15			SHIELDED, SNAP PEG		
T	N08-0100	SH	09/25/08		0.XXX±0.05			dwg no		
U	N08-0239	SH	11/10/08	dr	KCHOU	3/18/93	sheet 6 of 6		size	
V	ELX-N-010997	SH	MMO	3/14/12	engr	TC	3/18/93	94910		A4
				chr	J.TSAO	3/18/93	type		Product Customer Drawing	
sheet index		revision sheet								