

2.75kV E-Rated medium voltage fuses for feeder circuit, switchgear and transformer protection



Description:

- E-Rated, current-limiting, medium voltage fuses for feeder circuit, switchgear and transformer protection.

Features and benefits

- Current-limiting E-Rated medium voltage fuses are defined by their melting time-current characteristic that permit their electrical interchangeability with other fuses of the same E Rating.
- E-Rated fuses must have a defined current response time specified by ANSI C37.46. E-Rated fuse of 100 amps and below must melt in 300 seconds at an RMS current within the range of 200% to 240% of the fuse's nameplate current rating. E-Rated fuses greater than 100 amps must melt in 600 seconds at an RMS current within the range of 220% to 264% of the fuse's nameplate current rating.
- E-Rated fuses are physically dimensioned for easy installation in existing hardware.
- Current-limiting fuses provide positive interruption even on low fault currents. The fuse limits the magnitude of electromechanical stresses in the protected apparatus.
- Open fuse indicator speeds troubleshooting by providing a positive visual indication of fuse operation.
- 50/60Hz operating frequency for worldwide application.
- Mountings are available in disconnect and non-disconnect versions with porcelain or glass polyester insulators.
- Live parts and end fittings available.

Typical applications:

- Medium voltage transformer primary protection
- Medium voltage feeder circuit protection
- Medium voltage switches
- Medium voltage metal-enclosed switchgear

2.75kV E-Rated medium voltage ferrule fuses

Catalog symbols:

- 2CLE-_E
- JCX-_E

Ratings:

- Volts — 2.75kV
- Amps — 10 to 450A
- Interrupting ratings
 - 50kA RMS Sym (2CLE-_E)
 - 40kA RMS Sym (JCX-_E)

Agency information:

- E-Rated fuses meet the performance characteristics of ANSI C37.46

Dimensions (see catalog number tables for values)

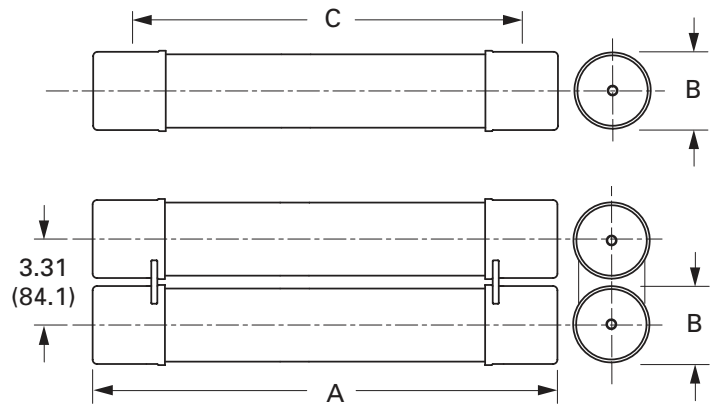

Recommended fuse holders:

CLE

Amp rating	Fuse mounting type*	Voltage BIL (kV)	Approximate dimensions - in (mm)		Length C	Mounting (including live parts, end fittings)**		Live parts (including end fittings)	End fittings (disconnect only)
			Diameter A	Clip center B		Porcelain insulator	Glass-polyester insulator		
			CLE						
15E-25E Single barrel	Non-disconnect	60	2 (51)	8.1 (206)	9.5 (241)	2CLE-PNM-C	2CLE-GNM-C	CLE-NL-C	—
	Disconnect†	60				2CLE-PDM-C	2CLE-GDM-C	CLE-DL-C	CLE-DF-C
10E-225E Single barrel	Non-disconnect	60	3 (76)	7 (178)	10.9 (277)	2CLE-PNM-D	2CLE-GNM-D	CLE-NL-D	—
	Disconnect†	60				2CLE-PDM-D	2CLE-GDM-D	CLE-DL-D	CLE-DF-D
250E-300E 350X-450X Double barrel	Non-disconnect	60	3 (76)	7 (178)	10.9 (277)	2CLE-PNM-E	2CLE-GNM-E	CLE-NL-E	—
	Disconnect†	60				2CLE-PDM-E	5CLE-GDM-E	CLE-DL-E	CLE-DF-E

* See page 9 for illustrations and dimensions.

** End fittings supplied only when required.

† Disconnect mountings provide a means for fuse extraction only. Do not use a disconnect mounting for load switching or fuse removal while energized.

Recommended fuseclips:

Description	Fuse diameter - in (mm)	Figure	Clip dimensions - in (mm)							Catalog number
			A	B	C	D	E	F	G	
Enclosed fuseclip	2 (51)	1	3.75 (95)	1.98 (50)	2.01 (51)	1.19 (30)	4.54 (115)	1.51 (38)	0.4 (10)	A3354710*
Enclosed fuseclip	3 (76)	1	4.14 (105)	2.45 (62)	3.01 (76)	1.19 (30)	5.64 (143)	1.51 (38)	0.4 (10)	A3354730*
Open fuseclip	3 (76)	2	See dimensions drawing							1A0065
Spring loaded open fuseclip	3 (76)	3	See dimensions drawing							9078A67G04

*For single barrel applications only. Not sold in pairs.

Figure 1

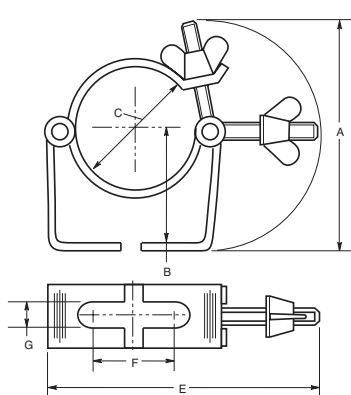

Figure 2

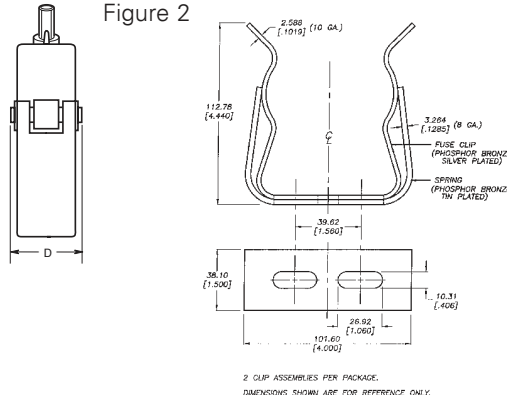
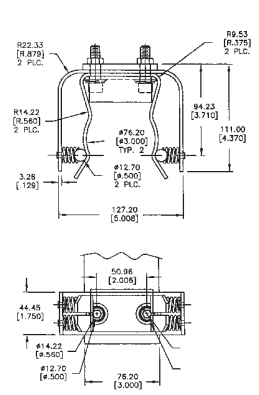

Figure 3



CLE and JCX

Amp rating	Dimensions - in (mm)			Interrupting rating kA (RMS Sym.)	Number of barrels	Installation location	Catalog number
	Length A	Diameter B	Clip centers C				
1	9.2 (234)	2 (51)	7 (178)	40	1	Indoor/outdoor	JCX-1E
2	9.2 (234)	2 (51)	7 (178)	40	1	Indoor/outdoor	JCX-2E
3	9.2 (234)	2 (51)	7 (178)	40	1	Indoor/outdoor	JCX-3E
5	9.2 (234)	2 (51)	7 (178)	40	1	Indoor/outdoor	JCX-5E
7	9.2 (234)	2 (51)	7 (178)	40	1	Indoor/outdoor	JCX-7E
10	9.2 (234)	2 (51)	7 (178)	40	1	Indoor/outdoor	JCX-10E
10	10.9 (277)	3 (76)	7 (178)	50	1	Indoor	2CLE-10E
15	9.5 (241)	2 (51)	8.1 (206)	50	1	Indoor	2CLE-15E
20	9.5 (241)	2 (51)	8.1 (206)	50	1	Indoor	2CLE-20E
25	9.5 (241)	2 (51)	8.1 (206)	50	1	Indoor	2CLE-25E
30	10.9 (277)	3 (76)	7 (178)	50	1	Indoor	2CLE-30E
40	10.9 (277)	3 (76)	7 (178)	50	1	Indoor	2CLE-40E
50	10.9 (277)	3 (76)	7 (178)	50	1	Indoor	2CLE-50E
65	10.9 (277)	3 (76)	7 (178)	50	1	Indoor	2CLE-65E
80	10.9 (277)	3 (76)	7 (178)	50	1	Indoor	2CLE-80E
100	10.9 (277)	3 (76)	7 (178)	50	1	Indoor	2CLE-100E
125	10.9 (277)	3 (76)	7 (178)	50	1	Indoor	2CLE-125E
150	10.9 (277)	3 (76)	7 (178)	50	1	Indoor	2CLE-150E
200	10.9 (277)	3 (76)	7 (178)	50	1	Indoor	2CLE-200E
225	10.9 (277)	3 (76)	7 (178)	50	1	Indoor	2CLE-225E
250*	10.9 (277)	3 (76)	7 (178)	50	2	Indoor	2CLE-250E
300*	10.9 (277)	3 (76)	7 (178)	50	2	Indoor	2CLE-300E
350**	10.9 (277)	3 (76)	7 (178)	50	2	Indoor	2CLE-350X
400**	10.9 (277)	3 (76)	7 (178)	50	2	Indoor	2CLE-400X
450**	10.9 (277)	3 (76)	7 (178)	50	2	Indoor	2CLE-450X

* 250A and 300A ratings may also be applied at 280 and 325 amps respectively, but fuses will no longer be complaint with ANSI E Rating criteria.

** Does not comply with ANSI C37.46 for "E" rating.

2.75kV Time-current curves — minimum melt for JCX-E

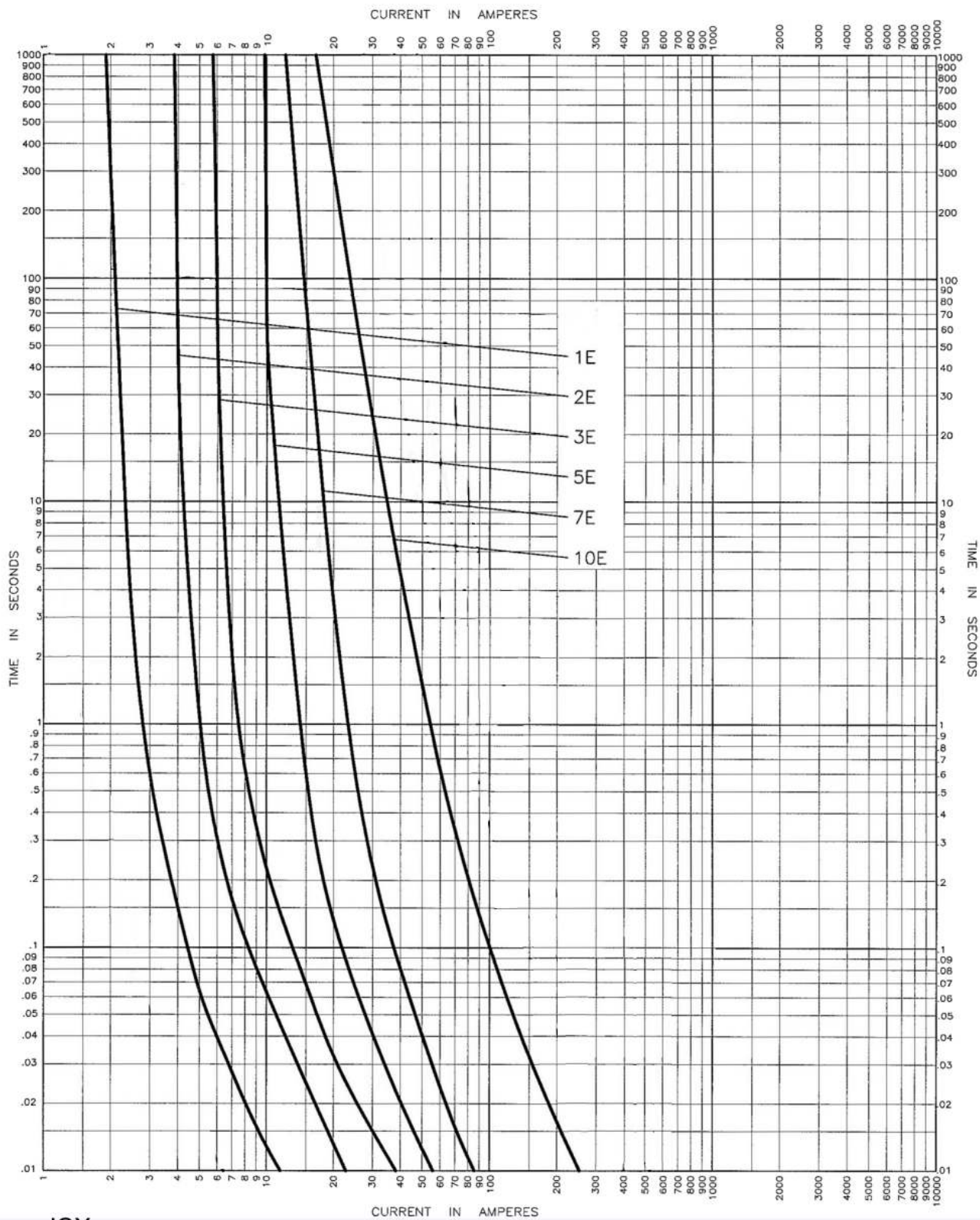

JCX-

2.75kV Time-current curves – total clear for JCX-E

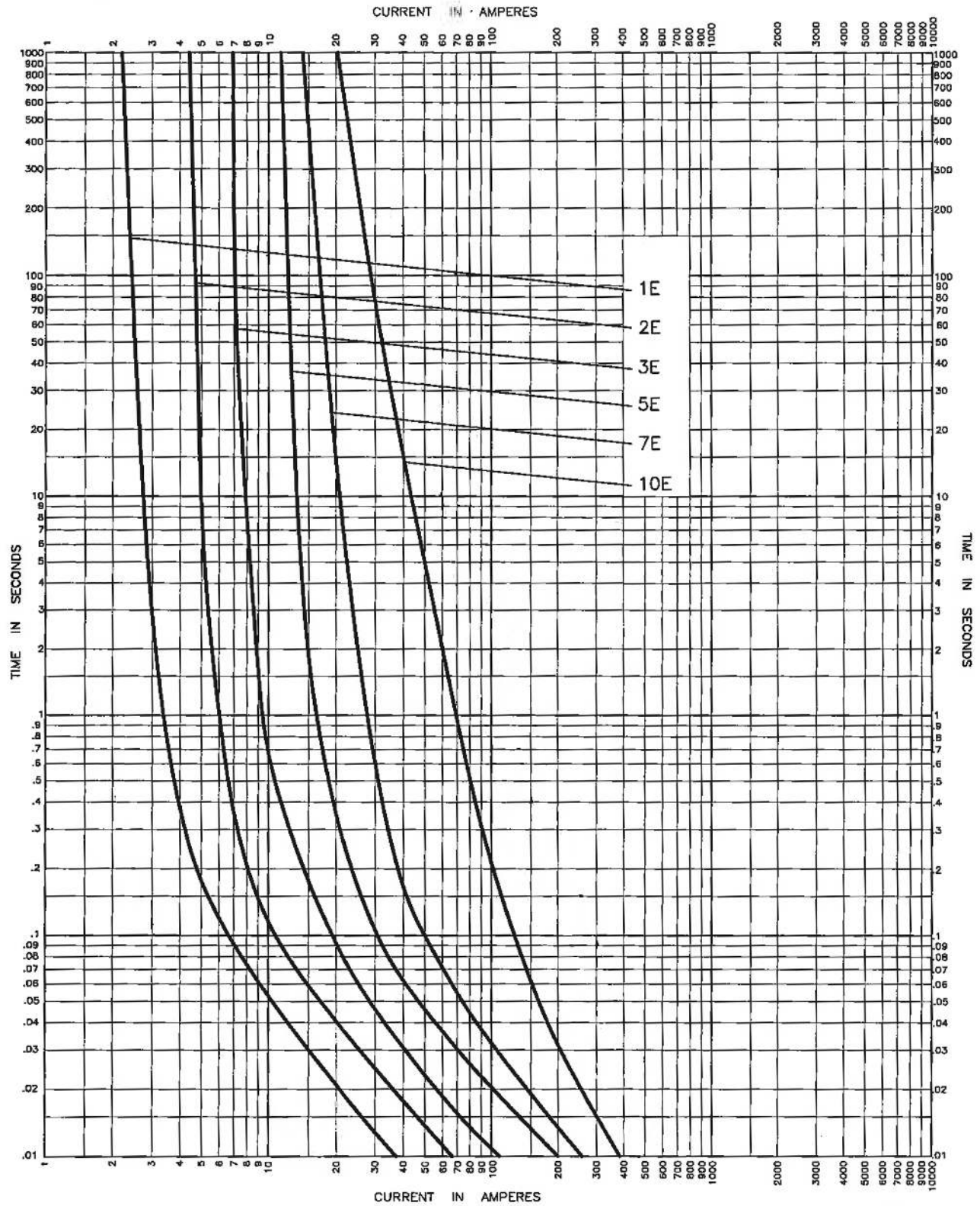

JCX-

2.75kV Time-current curves — minimum melt for 2CLE-E and 2CLE-X

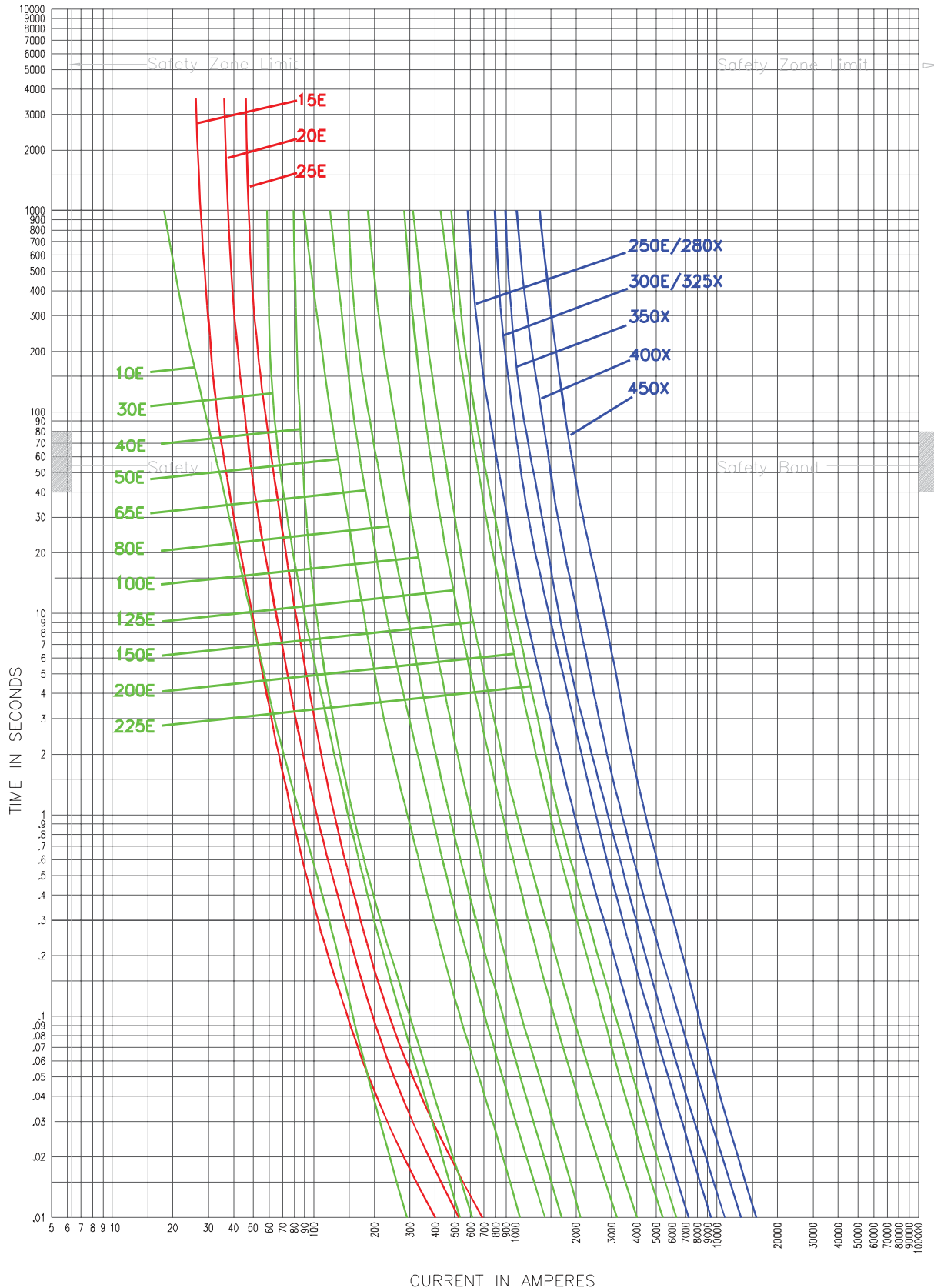

Curve 53653202	Curve 53686104	Curve 53690002
July 2001	July 2001	July 2001
Reference # 563532	Reference # 536861	Reference # 536900

2CLE-

2.75kV Time-current curves — total clear for 2CLE-E and 2CLE-X

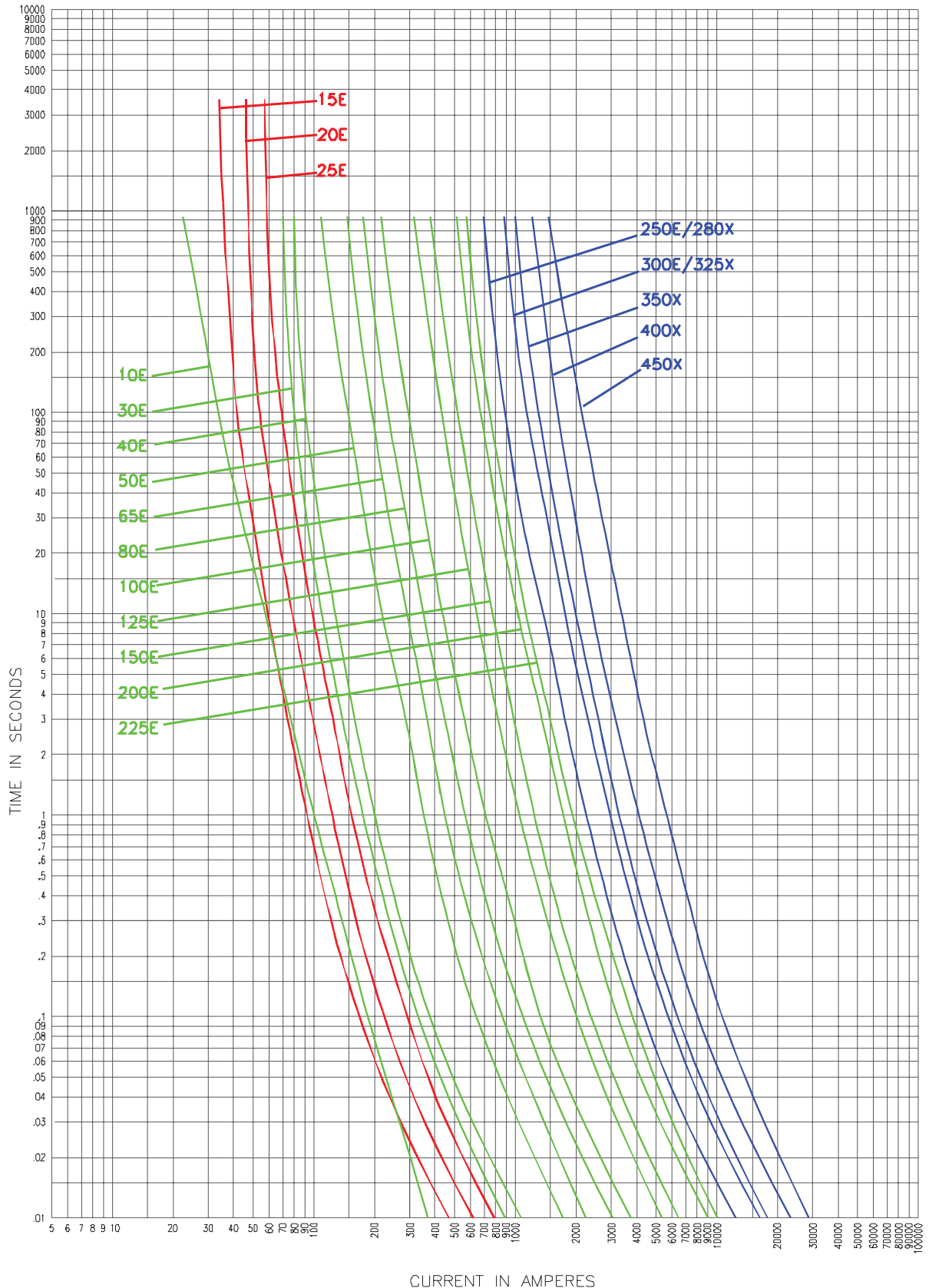

2CLE-

Curve 56353302	Curve 53686204	Curve 53690102
July 2001	July 2001	July 2001
Reference # 563533	Reference # 536862	Reference # 536901

2.75kV Peak let-through for 2CLE-E and 2CLE-X

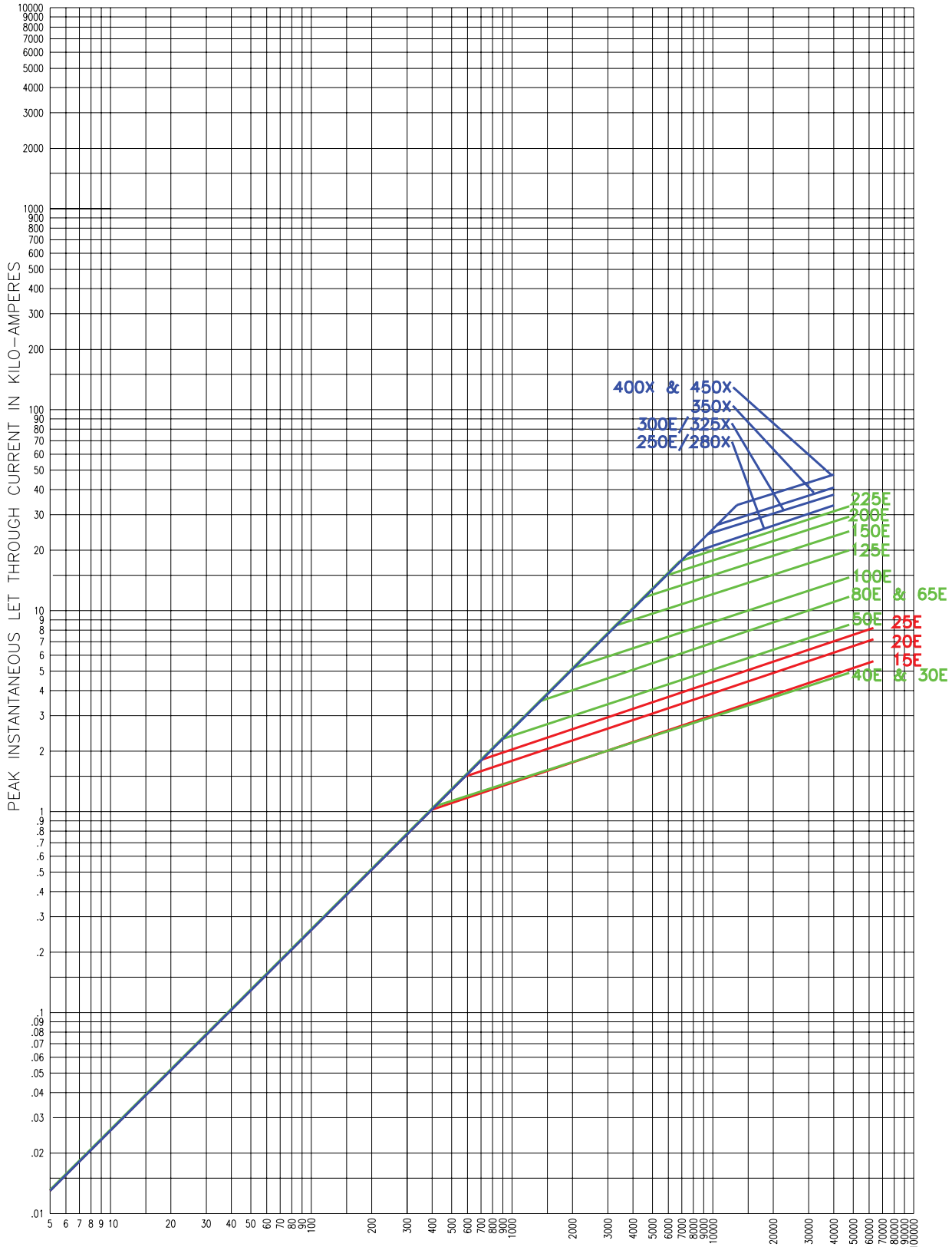

AVAILABLE CURRENT IN AMPERES

- | | | |
|--------------------|--------------------|--------------------|
| Curve 63931702 | Curve 63931704 | Curve 63931802 |
| July 2001 | May 2002 | July 2001 |
| Reference # 639317 | Reference # 639317 | Reference # 639318 |

2CLE-

CLE Type mountings - in (mm)

Catalog number	Hole centers		Overall length C	Hole Inset D	Hole centers E	Contact height F	Overall height G	BIL kV
	A	B						
Disconnect single barrel†								
2CLE-GDM-C	9.37 (238.0)	6 (152.4)	22.13 (562.1)	0.75 (19.0)	1.75 (44.4)	4.5 (114.3)	9.75 (247.6)	60
2CLE-GDM-D	8.24 (209.3)	6 (152.4)	18 (457.2)	0.62 (15.7)	1.75 (44.4)	4.5 (114.3)	11.72 (297.7)	60
2CLE-PDM-C	9.37 (238.0)	6 (152.4)	22.13 (562.1)	0.75 (19.0)	1.75 (44.4)	4.5 (114.3)	9.75 (247.6)	60
2CLE-PDM-D	8.24 (209.3)	6 (152.4)	18 (457.2)	0.62 (15.7)	1.75 (44.4)	4.5 (114.3)	11.72 (297.7)	60
Disconnect double barrel†								
2CLE-GDM-E	8.24 (209.3)	6 (152.4)	18 (457.2)	0.62 (15.7)	1.75 (44.4)	4.5 (114.3)	15.28 (388.1)	60
2CLE-PDM-E	8.24 (209.3)	6 (152.4)	18 (457.2)	0.62 (15.7)	1.75 (44.4)	4.5 (114.3)	15.28 (388.1)	60
Non-disconnect single barrel								
2CLE-GNM-C	9.37 (238.0)	6 (152.4)	18.63 (473.2)	0.75 (19.0)	1.75 (44.4)	4.5 (114.3)	7.25 (184.1)	60
2CLE-PNM-C	9.37 (238.0)	6 (152.4)	18.63 (473.2)	0.75 (19.0)	1.75 (44.4)	4.5 (114.3)	7.25 (184.1)	60
2CLE-GNM-D	8.24 (209.3)	6 (152.4)	18 (457.2)	0.62 (15.7)	1.75 (44.4)	4.5 (114.3)	8.79 (223.3)	60
2CLE-PNM-D	8.24 (209.3)	6 (152.4)	18 (457.2)	0.62 (15.7)	1.75 (44.4)	4.5 (114.3)	8.79 (223.3)	60
Non-disconnect double barrel								
2CLE-GNM-E	8.24 (209.3)	6 (152.4)	18 (457.2)	0.62 (15.7)	1.75 (44.4)	4.5 (114.3)	12.48 (317.0)	60
2CLE-PNM-E	8.24 (209.3)	6 (152.4)	18 (457.2)	0.62 (15.7)	1.75 (44.4)	4.5 (114.3)	12.48 (317.0)	60

CLE Type disconnect mounting†

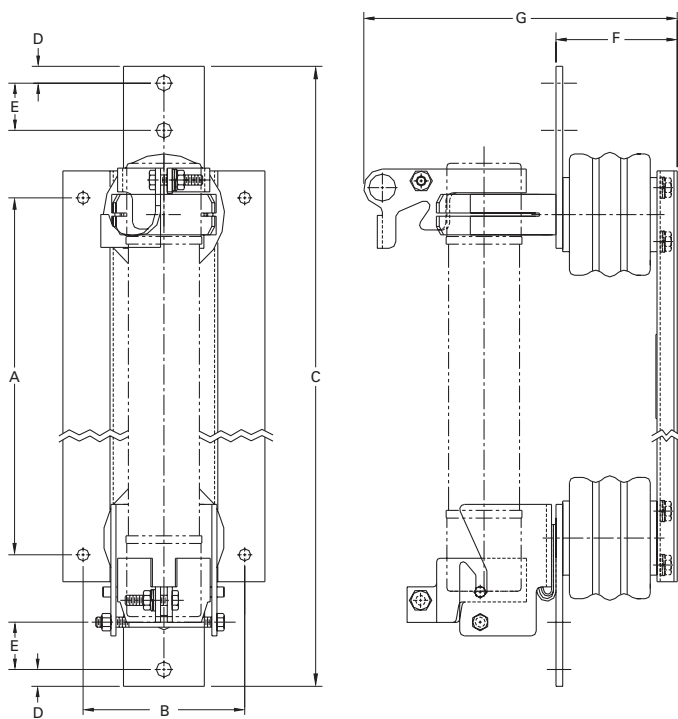

CLE Type non-disconnect mounting

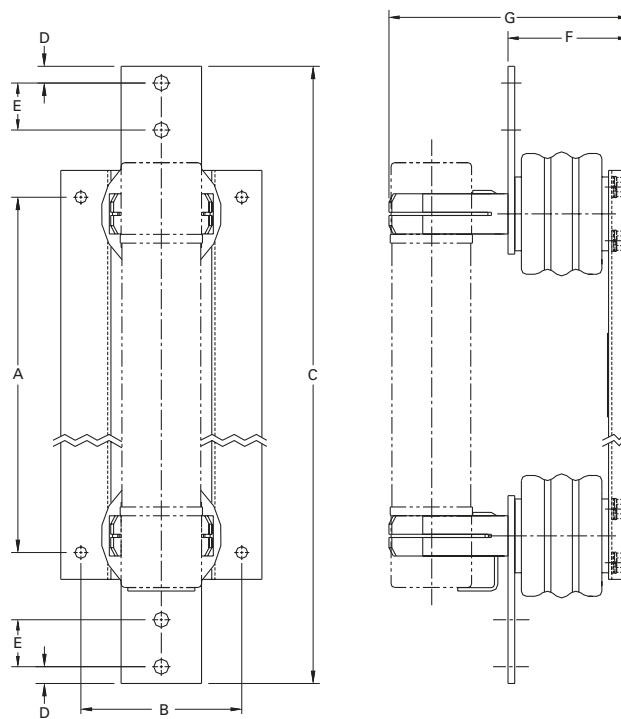

† Disconnect mountings provide a means for fuse extraction only. Do not use a disconnect mounting for load switching or fuse removal while energized.

The only controlled copy of this Data Sheet is the electronic read-only version located on the Bussmann Network Drive. All other copies of this document are by definition uncontrolled. This bulletin is intended to clearly present comprehensive product data and provide technical information that will help the end user with design applications. Bussmann reserves the right, without notice, to change design or construction of any products and to discontinue or limit distribution of any products. Bussmann also reserves the right to change or update, without notice, any technical information contained in this bulletin. Once a product has been selected, it should be tested by the user in all possible applications.

Eaton

1000 Eaton Boulevard
Cleveland, OH 44122
Eaton.com

Bussmann Division
114 Old State Road
Ellisville, MO 63021
United States
Eaton.com/bussmannseries

© 2019 Eaton
All Rights Reserved
Printed in USA
Publication No. 10350
October 2019

Eaton and Bussmann are valuable trademarks of Eaton in the U.S. and other countries. You are not permitted to use the Eaton trademarks without prior written consent of Eaton.

ANSI is a registered trademark of the American National Standards Association
IEEE is a registered trademark of the Institute of Electrical and Electronics Engineers
NEMA is a registered trademark of the National Electrical Mfgs. Association
NFPA is a registered trademark of the National Fire Protection Association
UL is a registered trademark of the Underwriters Laboratories, Inc.