

THIS DRAWING IS UNPUBLISHED. RELEASED FOR PUBLICATION
 © COPYRIGHT - TE Connectivity Ltd. ALL RIGHTS RESERVED.

| REVISIONS | | | | | |
|-----------|-----|--------------------------------------|-----------|-----|------|
| P | LTR | DESCRIPTION | DATE | DWN | APVD |
| B | | REV, RDRW, & SM PKG PER 0720-0040-93 | 9-26-93 | TAB | DAP |
| B1 | | REVISED PER ECO-17-008808 | 03MAR2018 | RS | DR |

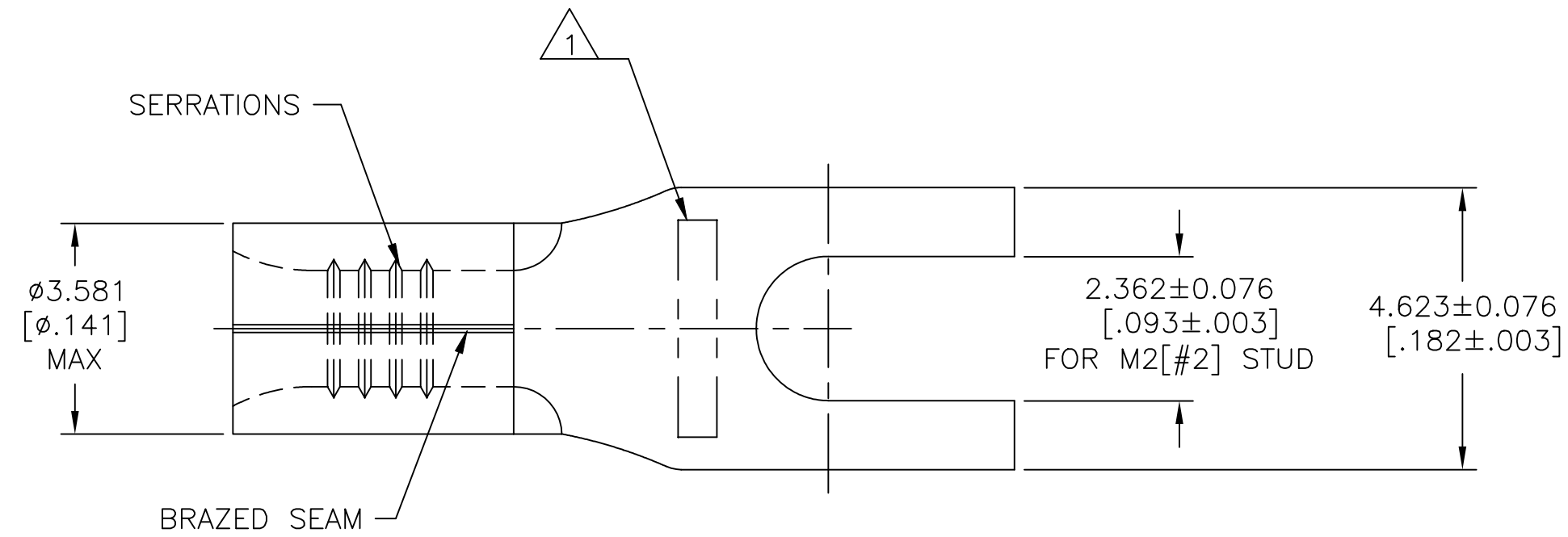

| | |
|--------------------------------|--------------------------------|
| AMP WIRE RANGE | E13288 Listed |
| 22-16 AWG SOLID OR STRANDED | 22-16 AWG SOLID OR STRANDED |
| LR7189 Certified | MILITARY P/N AND CLASS |
| 22-16 AWG SOLID OR STRANDED | NOT APPLICABLE |

STAMP AMP 22-18* APPROX AS SHOWN
 22-16 TERMINALS ARE STAMPED 22-18 IN
 ACCORDANCE WITH MILITARY SPECIFICATION
 SAE AS7928, COMMERCIAL WIRE RANGE IS 22-16

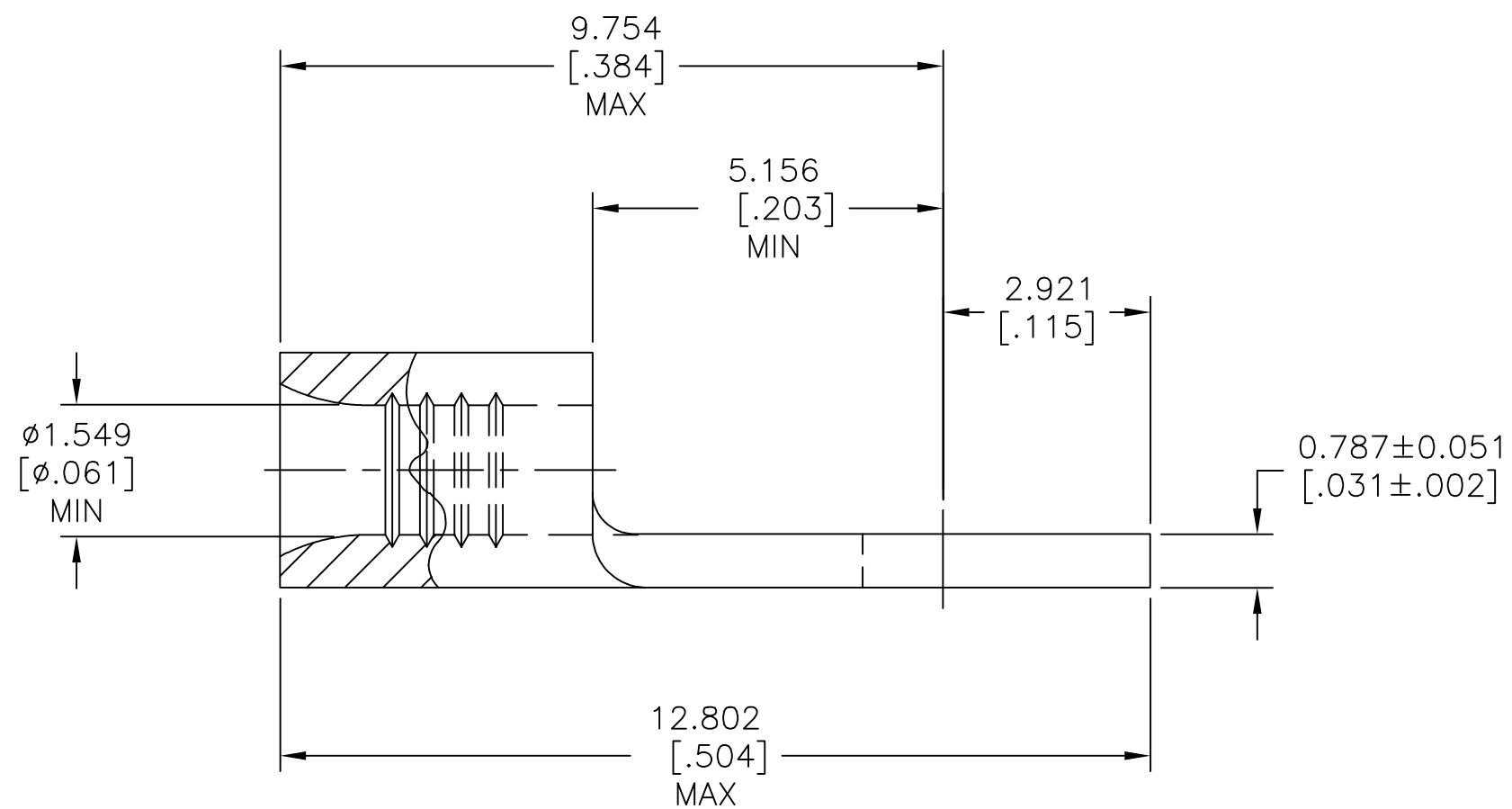

| | | |
|----------|------------------|-----------|
| 100 | LOOSE PIECE, BOX | 8-53555-1 |
| 1000 | LOOSE PIECE | 53555-1 |
| QUANTITY | PACKAGING TYPE | PART NO |

| | | | | | | | | |
|-------------------------------------------------------------------------------------------|----------------------------------------------|--------------------------------------------------------------------------------------------------------|--------------------------------------------------|---------------------------------------------------------------------------------------|--------------------------------|----------------------------|--------------------|-----------------------|
| AMP INCORPORATED CUSTOMER SERVICE SYSTEMS | | | THIS DRAWING IS A CONTROLLED DOCUMENT. | | DWN TA BRINKMAN 3-26-93 | TE Connectivity Ltd. | | |
| FOR ADDITIONAL PRODUCT INFORMATION OR COPIES OF DRAWINGS AND TECHNICAL DOCUMENTS | PRODUCT INFORMATION CENTER 1-800-522-6752 | MAX RECOMMENDED OPERATING TEMPERATURE: 170°C [338°F] MAX | DIMENSIONS: mm [INCHES] | TOLERANCES UNLESS OTHERWISE SPECIFIED: | CHK DA PATTERSON 3-26-93 | NAME DE MILLER | | |
| FOR APPLICATION | TOOLING ASSISTANCE CENTER 1-800-722-1111 | VOLTAGE RATING: NOT APPLICABLE | | 0 PLC ± - 1 PLC ± - 2 PLC ± - 3 PLC ± 0.127[.005] 4 PLC ± - ANGLES ± - | APVD DE MILLER 3-26-93 | PRODUCT SPEC UL 486 A-B | | |
| TOOLING INFORMATION | 1-800-722-1111 | WIRE CROSS SECTIONAL AREA RANGE, 0.26-1.65mm ² [509-3,260] CIR MILS SOLID OR STRANDED | MATERIAL COPPER PER ASTM B-152 ANNEALED | FINISH TIN PLATE 0.00254[.000100] MIN THK PER ASTM B545 | APPLICATION SPEC - | SIZE A2 | CAGE CODE 00779 | DRAWING NO C=53555 |
| FOR ORDER ENTRY | 1-800-526-5142 | | | | WEIGHT - | RESTRICTED TO - | SCALE 10:1 | SHEET 1 of 1 |
| | | | | | CUSTOMER DRAWING | REV B1 | | |