

**SPIRIT1 315 MHz low data rate transceiver daughterboard**

Data brief

**Description**

The STEVAL-IKR002V2D product evaluation board is based on the SPIRIT1, a very low-power RF transceiver intended for RF wireless applications in the sub-1 GHz frequency band.

**Features**

- SPIRIT1 low power sub GHz transceiver in a standalone RF module tuned for 315 MHz
- Modulation schemes: 2-FSK, GFSK, MSK, GMSK, OOK, and ASK
- Programmable air data rate: from 1 to 500 kbps
- Very low power consumption: 9.2 mA RX and 22 mA TX at +11 dBm
- Excellent receiver sensitivity (down to -110 dBm)
- Low duty cycle RX/TX operation mode
- Automatic acknowledgment, retransmission, and timeout protocol engine
- AES 128-bit encryption co-processor
- SPI interface for microcontroller
- RoHS compliant

# 1 Schematic diagram

Figure 1. STEVAL-IKR002V2D circuit schematic

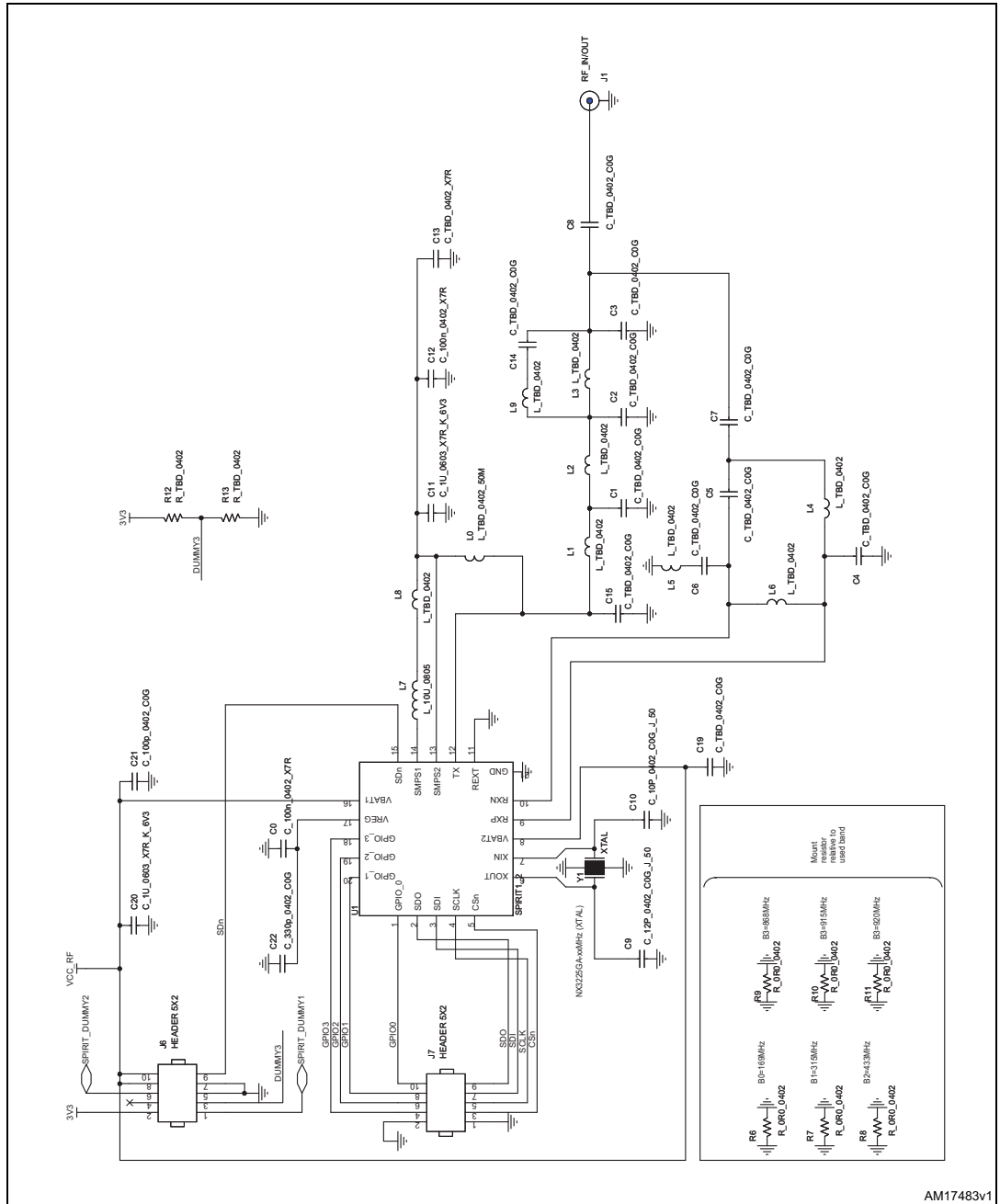

AM17483v1



## 2 Revision history

Table 1. Document revision history

Date	Revision	Changes
02-Oct-2014	1	Initial release.

**IMPORTANT NOTICE – PLEASE READ CAREFULLY**

STMicroelectronics NV and its subsidiaries ("ST") reserve the right to make changes, corrections, enhancements, modifications, and improvements to ST products and/or to this document at any time without notice. Purchasers should obtain the latest relevant information on ST products before placing orders. ST products are sold pursuant to ST's terms and conditions of sale in place at the time of order acknowledgement.

Purchasers are solely responsible for the choice, selection, and use of ST products and ST assumes no liability for application assistance or the design of Purchasers' products.

No license, express or implied, to any intellectual property right is granted by ST herein.

Resale of ST products with provisions different from the information set forth herein shall void any warranty granted by ST for such product.

ST and the ST logo are trademarks of ST. All other product or service names are the property of their respective owners.

Information in this document supersedes and replaces information previously supplied in any prior versions of this document.

© 2014 STMicroelectronics – All rights reserved