

# NHD-C12864LZ-NSW-FBW-3V3

## COG (Chip-On-Glass) Liquid Crystal Display Module

NHD-	Newhaven Display
C12864-	128 x 64 Pixels
LZ-	Model
N-	Transmissive
SW-	Side White LED Backlight
F-	FSTN, Negative
B-	6:00 Optimal View
W-	Wide Temperature
3V3-	3V LCD, 3V Backlight
	<b>RoHS Compliant</b>

**Newhaven Display International, Inc.**

2661 Galvin Court

Elgin IL, 60124

Ph: 847-844-8795

Fax: 847-844-8796

[www.newhavendisplay.com](http://www.newhavendisplay.com)

[nhtech@newhavendisplay.com](mailto:nhtech@newhavendisplay.com)

[nhsales@newhavendisplay.com](mailto:nhsales@newhavendisplay.com)

## Document Revision History

Revision	Date	Description	Changed by
0	10/12/16	Initial Release	AK
1	8/15/17	Backlight Redesign	SB
2	5/29/19	Added PCB Footprint Drawing & Recommended Breakout Board	AS

## Functions and Features

- 128 x 64 pixels
- Parallel / Serial MPU interface
- Built-in ST7565R-G Controller
- +3.0V power supply
- 1/65 duty cycle; 1/9 bias
- RoHS Compliant

# Mechanical Drawing

SYMBOL	REVISION	DATE

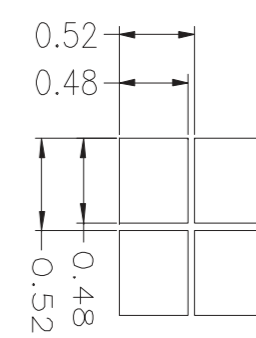
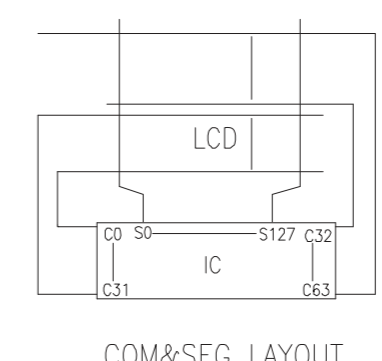
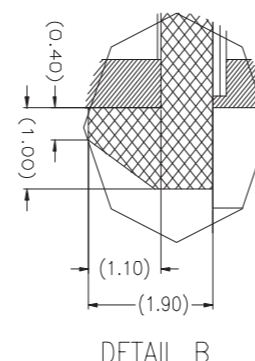
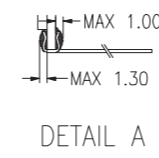
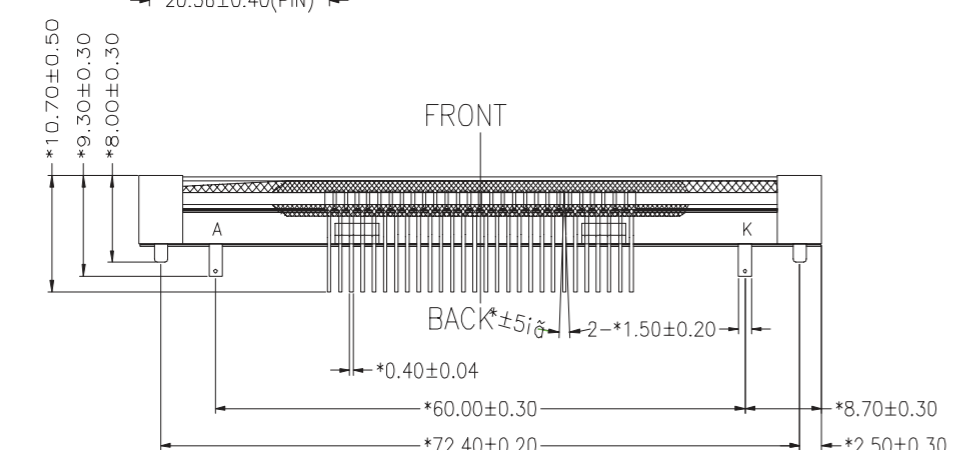
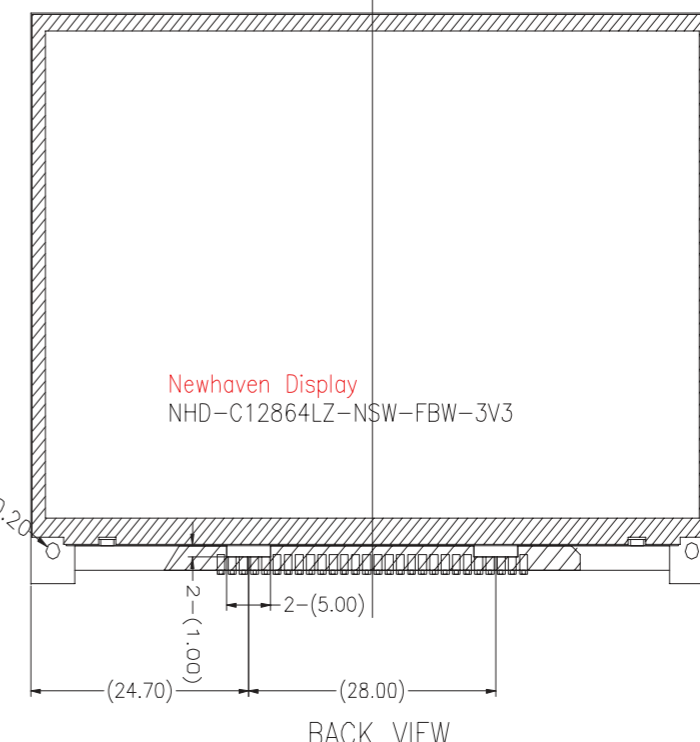
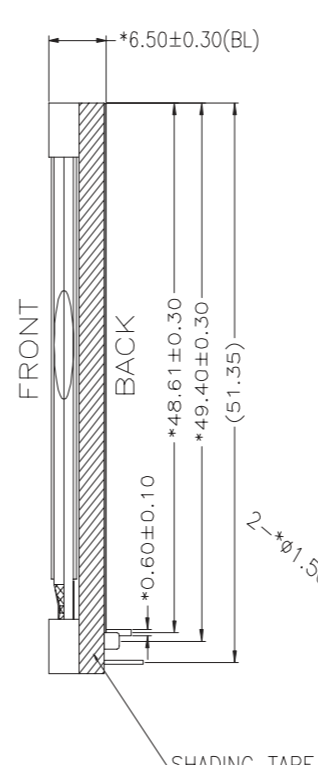
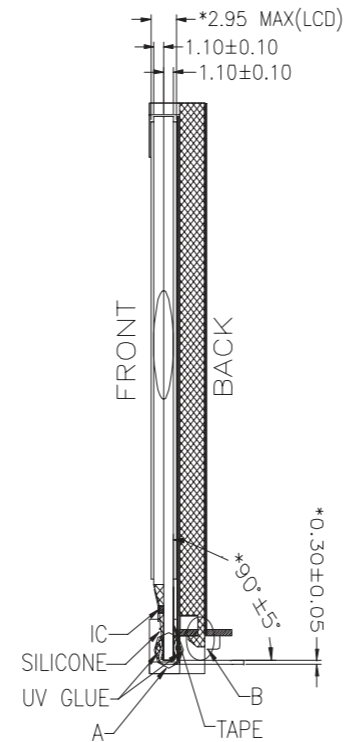
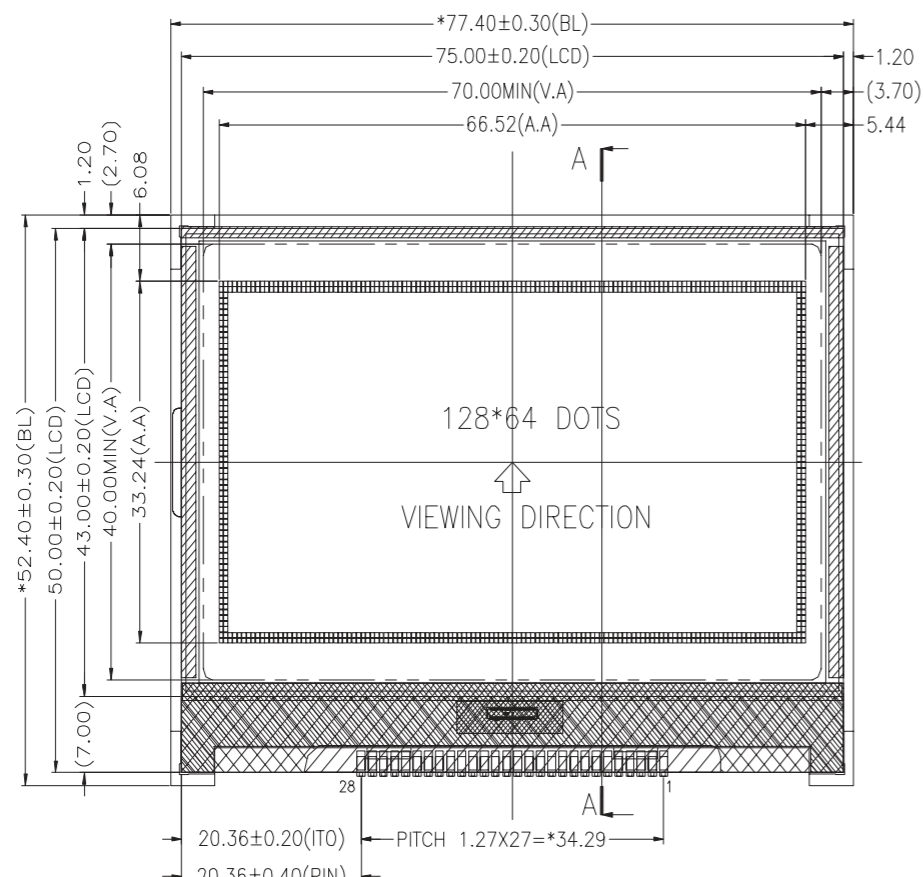

- Notes:**
- Driving: 1/65 Duty, 1/9 Bias
  - Voltage: 3.0V V<sub>DD</sub>, 8.7V V<sub>LCD</sub>
  - Display Type: FSTN Negative/ Transmissive
  - Optimal View: 6:00
  - Backlight: White LED
  - Driver IC: ST7565R

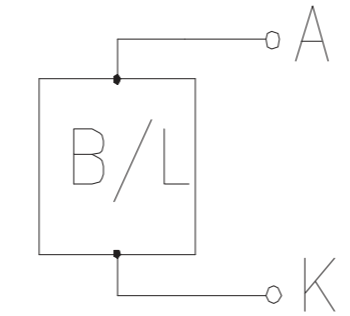

PIN	1	2	3	4	5	6	7	8	9	10	11	12	13	14
CONNECTION	CS1	/RES	A0	/WR	/RD	DB0	DB1	DB2	DB3	DB4	DB5	DB6	DB7	VDD
PIN	15	16	17	18	19	20	21	22	23	24	25	26	27	28
CONNECTION	VSS	VOUT	CAP3P	CAP1N	CAP1P	CAP2P	CAP2N	V4	V3	V2	V1	V0	C86	P/S

STANDARD TOLERANCE: (UNLESS OTHERWISE SPECIFIED)

LINEAR: ±0.3mm

UNLESS OTHERWISE SPECIFIED:  
- DIMENSIONS ARE IN MILLIMETERS  
- THIRD ANGLE PROJECTION

THIS DRAWING IS SOLELY THE PROPERTY OF NEWHAVEN DISPLAY INTERNATIONAL, INC. THE INFORMATION IT CONTAINS IS NOT TO BE DISCLOSED, REPRODUCED OR COPIED IN WHOLE OR PART WITHOUT WRITTEN APPROVAL FROM NEWHAVEN DISPLAY.

**NEWHAVEN DISPLAY INTERNATIONAL**

DRAWING/PART NUMBER: NHD-C12864LZ-NSW-FBW-3V3

REVISION: 1.0  
SIZE: A3  
SCALE: NS

DRAWN BY: A. Shah  
APPROVED BY: A. Khan



DRAWN DATE: 5/29/19  
APPROVED DATE: 5/29/19

DO NOT SCALE DRAWING SHEET 1 OF 1

# Recommended PCB Footprint

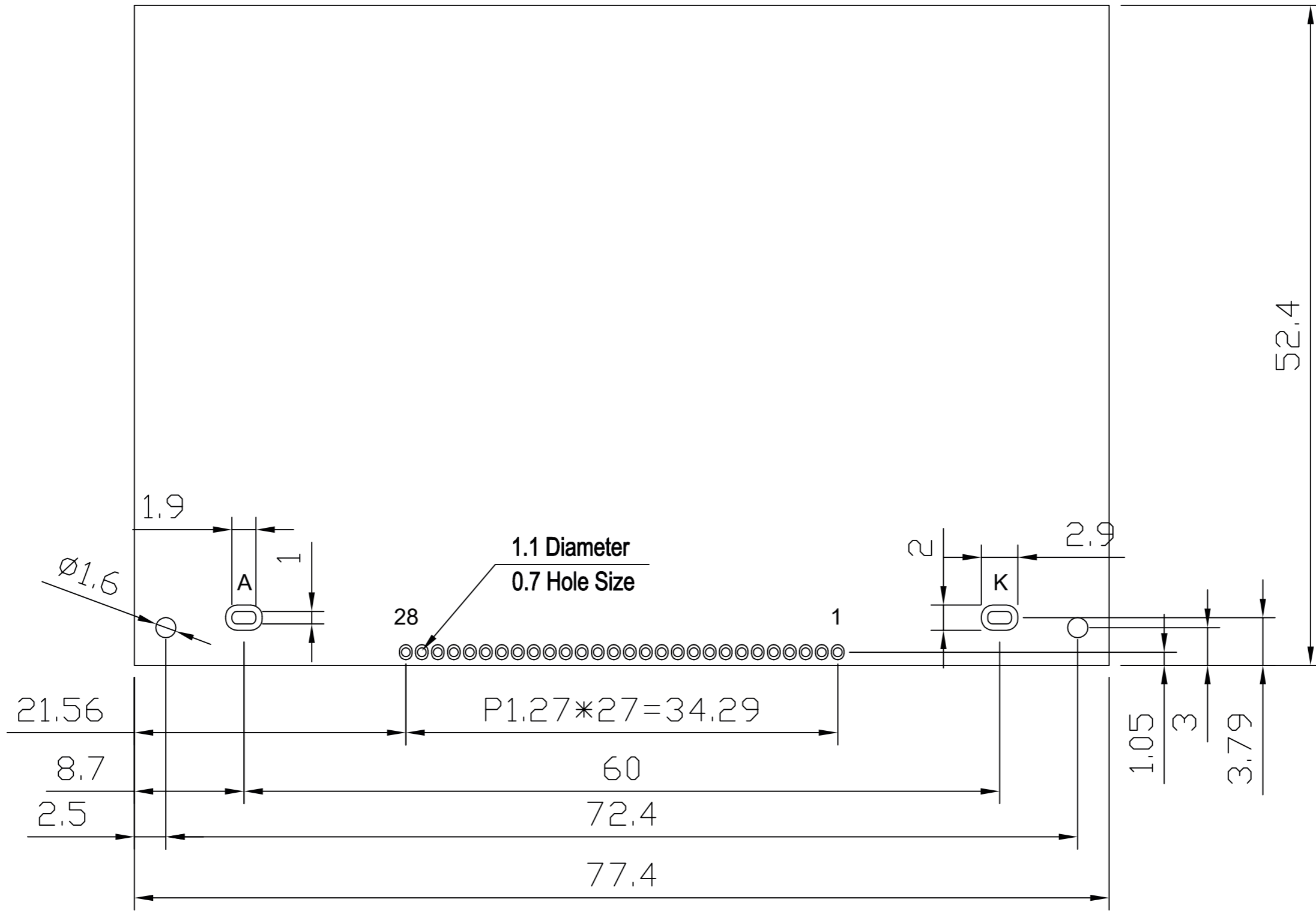
SYMBOL	REVISION	DATE



STANDARD TOLERANCE: (UNLESS OTHERWISE SPECIFIED)		 <b>NEWHAVEN DISPLAY</b> INTERNATIONAL	
LINEAR: ±0.3mm		DRAWING/PART NUMBER: <b>NHD-C12864LZ Footprint</b>	
UNLESS OTHERWISE SPECIFIED: - DIMENSIONS ARE IN MILLIMETERS - THIRD ANGLE PROJECTION 		DRAWN BY: A. Shah	APPROVED BY: A. Khan
		DRAWN DATE: 5/28/19	APPROVED DATE: 5/28/19
		DO NOT SCALE DRAWING	
		SHEET 1 OF 1	
THIS DRAWING IS SOLELY THE PROPERTY OF NEWHAVEN DISPLAY INTERNATIONAL, INC. THE INFORMATION IT CONTAINS IS NOT TO BE DISCLOSED, REPRODUCED OR COPIED IN WHOLE OR PART WITHOUT WRITTEN APPROVAL FROM NEWHAVEN DISPLAY.			

## Pin Description and Wiring Diagram

Pin No.	Symbol	External Connection	Function Description		
1	/CS1	MPU	Active LOW chip select		
2	/RES	MPU	Active LOW Reset signal		
3	A0	MPU	Register select signal. 0: instruction; 1: data register		
4	R/W /WR	MPU	6800 Mode: Read/Write select signal. R/W=1: Read R/W: =0: Write 8080 Mode: Active LOW Write Signal		
5	E /RD	MPU	6800 Mode: Active HIGH Enable Signal 8080 Mode: Active LOW Read Signal		
6	DB0	MPU	Parallel Interface DB0-DB7: Bi-directional 8-bit data bus  Serial Interface: DB0-DB5: No connect in serial mode DB6= Serial clock (SCL) DB7= Serial data input (SI)		
7	DB1				
8	DB2				
9	DB3				
10	DB4				
11	DB5				
12	DB6				
13	DB7				
14	V <sub>DD</sub>			Power Supply	Supply Voltage for LCD and logic (+3.0V)
15	V <sub>SS</sub>			Power Supply	Ground
16	V <sub>OUT</sub>			Power Supply	Connect to 1uF cap to V <sub>SS</sub>
17	CAP3+			Power Supply	Connect to 1uF cap to CAP1- (PIN-18)
18	CAP1-			Power Supply	Connect to 1uF cap to CAP3+(PIN17) and CAP1+(PIN19)
19	CAP1+	Power Supply	Connect to 1uF cap to CAP1- (PIN-18)		
20	CAP2+	Power Supply	Connect to 1uF cap to CAP2- (PIN-21)		
21	CAP2-	Power Supply	Connect to 1uF cap to CAP2+ (PIN-20)		
22	V <sub>4</sub>	Power Supply	1.0uF-2.2uF cap to V <sub>SS</sub>		
23	V <sub>3</sub>	Power Supply	1.0uF-2.2uF cap to V <sub>SS</sub>		
24	V <sub>2</sub>	Power Supply	1.0uF-2.2uF cap to V <sub>SS</sub>		
25	V <sub>1</sub>	Power Supply	1.0uF-2.2uF cap to V <sub>SS</sub>		
26	V <sub>0</sub>	Power Supply	1.0uF-2.2uF cap to V <sub>SS</sub>		
27	C86	MPU	MPU interface Select pin. C86=H: 6800; C86=L: 8080		
28	PS	MPU	Parallel/Serial select. PS= H: Parallel; PS=L: Serial		

**LCD connector:** 1.27mm pitch pins.

**Backlight connector:** 1.5mm wide pins.

**Recommended Breakout Board:** [NHD-PCB40](#)

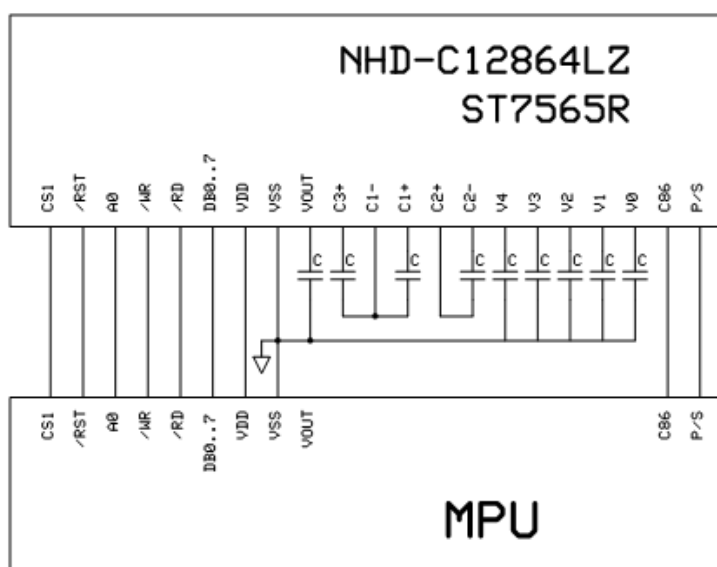

## Electrical Characteristics

Item	Symbol	Condition	Min.	Typ.	Max.	Unit
Operating Temperature Range	T <sub>OP</sub>	Absolute Max	-20	-	+70	°C
Storage Temperature Range	T <sub>ST</sub>	Absolute Max	-30	-	+80	°C
Supply Voltage	V <sub>DD</sub>	-	2.7	3.0	3.3	V
Supply Current	I <sub>DD</sub>	V <sub>DD</sub> = 3.0V	0.2	0.5	2.0	mA
Supply for LCD (contrast)	V <sub>DD</sub> - V <sub>0</sub>	T <sub>OP</sub> = 25°C	8.4	8.7	9.0	V
"H" Level input	V <sub>IH</sub>	-	0.8 * V <sub>DD</sub>	-	V <sub>DD</sub>	V
"L" Level input	V <sub>IL</sub>	-	V <sub>SS</sub>	-	0.2 * V <sub>DD</sub>	V
"H" Level output	V <sub>OH</sub>	-	0.8 * V <sub>DD</sub>	-	V <sub>DD</sub>	V
"L" Level output	V <sub>OL</sub>	-	V <sub>SS</sub>	-	0.2 * V <sub>SS</sub>	V
LED Backlight current	I <sub>LED</sub>	-	-	80	100	mA
LED Backlight voltage	V <sub>LED</sub>	I <sub>LED</sub> = 80mA	2.7	3.0	3.3	V

\*The LED of the backlight is driven by current drain; drive voltage is for reference only. Drive voltage must be selected to ensure backlight current drain is below MAX level stated.

## Optical Characteristics

Item	Symbol	Condition	Min.	Typ.	Max.	Unit
Optimal Viewing Angles	Top	Cr ≥ 2	-	35	-	°
	Bottom		-	35	-	°
	Left		-	40	-	°
	Right		-	40	-	°
Contrast Ratio	CR	-	2	5	-	-
Response Time	Rise	T <sub>OP</sub> = 25°C	-	150	250	ms
	Fall		-	200	300	ms

## Controller Information

Built-in ST7565R-G controller.

Please download specification at [http://www.newhavendisplay.com/app\\_notes/ST7565R.pdf](http://www.newhavendisplay.com/app_notes/ST7565R.pdf)

## Table of Commands

Command	Command Code										Function		
	A0	/RD	/WR	D7	D6	D5	D4	D3	D2	D1		D0	
(1) Display ON/OFF	0	1	0	1	0	1	0	1	1	1	0	1	LCD display ON/OFF 0: OFF, 1: ON
(2) Display start line set	0	1	0	0	1	Display start address						Sets the display RAM display start line address	
(3) Page address set	0	1	0	1	0	1	1	Page address				Sets the display RAM page address	
(4) Column address set upper bit	0	1	0	0	0	0	1	Most significant column address				Sets the most significant 4 bits of the display RAM column address.	
Column address set lower bit				0	0	0	0	Least significant column address				Sets the least significant 4 bits of the display RAM column address.	
(5) Status read	0	0	1	Status				0	0	0	0	Reads the status data	
(6) Display data write	1	1	0	Write data						Writes to the display RAM			
(7) Display data read	1	0	1	Read data						Reads from the display RAM			
(8) ADC select	0	1	0	1	0	1	0	0	0	0	0	1	Sets the display RAM address SEG output correspondence 0: normal, 1: reverse
(9) Display normal/reverse	0	1	0	1	0	1	0	0	1	1	0	1	Sets the LCD display normal/ reverse 0: normal, 1: reverse
(10) Display all points ON/OFF	0	1	0	1	0	1	0	0	1	0	0	1	Display all points 0: normal display 1: all points ON
(11) LCD bias set	0	1	0	1	0	1	0	0	0	1	0	1	Sets the LCD drive voltage bias ratio 0: 1/9 bias, 1: 1/7 bias (ST7565R)
(12) Read-modify-write	0	1	0	1	1	1	0	0	0	0	0	0	Column address increment At write: +1 At read: 0
(13) End	0	1	0	1	1	1	0	1	1	1	0	0	Clear read/modify/write
(14) Reset	0	1	0	1	1	1	0	0	0	1	0	0	Internal reset
(15) Common output mode select	0	1	0	1	1	0	0	0	*	*	*	*	Select COM output scan direction 0: normal direction 1: reverse direction
(16) Power control set	0	1	0	0	0	1	0	1	Operating mode		Select internal power supply operating mode		
(17) V <sub>0</sub> voltage regulator internal resistor ratio set	0	1	0	0	0	1	0	0	Resistor ratio		Select internal resistor ratio(Rb/Ra) mode		
(18) Electronic volume mode set	0	1	0	1	0	0	0	0	0	0	0	1	Set the V <sub>0</sub> output voltage electronic volume register
Electronic volume register set				0	0	Electronic volume value							
(19) Sleep mode set	0	1	0	1	0	1	1	0	0	0	0	1	0: Sleep mode, 1: Normal mode
(20) Booster ratio set	0	1	0	1	1	1	1	1	0	0	0	0	select booster ratio 00: 2x,3x,4x 01: 5x 11: 6x
(21) NOP	0	1	0	1	1	1	0	0	0	1	1	1	Command for non-operation
(22) Test	0	1	0	1	1	1	1	*	*	*	*	*	Command for IC test. Do not use this command



# Timing Characteristics

## System Bus Read/Write Characteristics 1 (For the 8080 Series MPU)

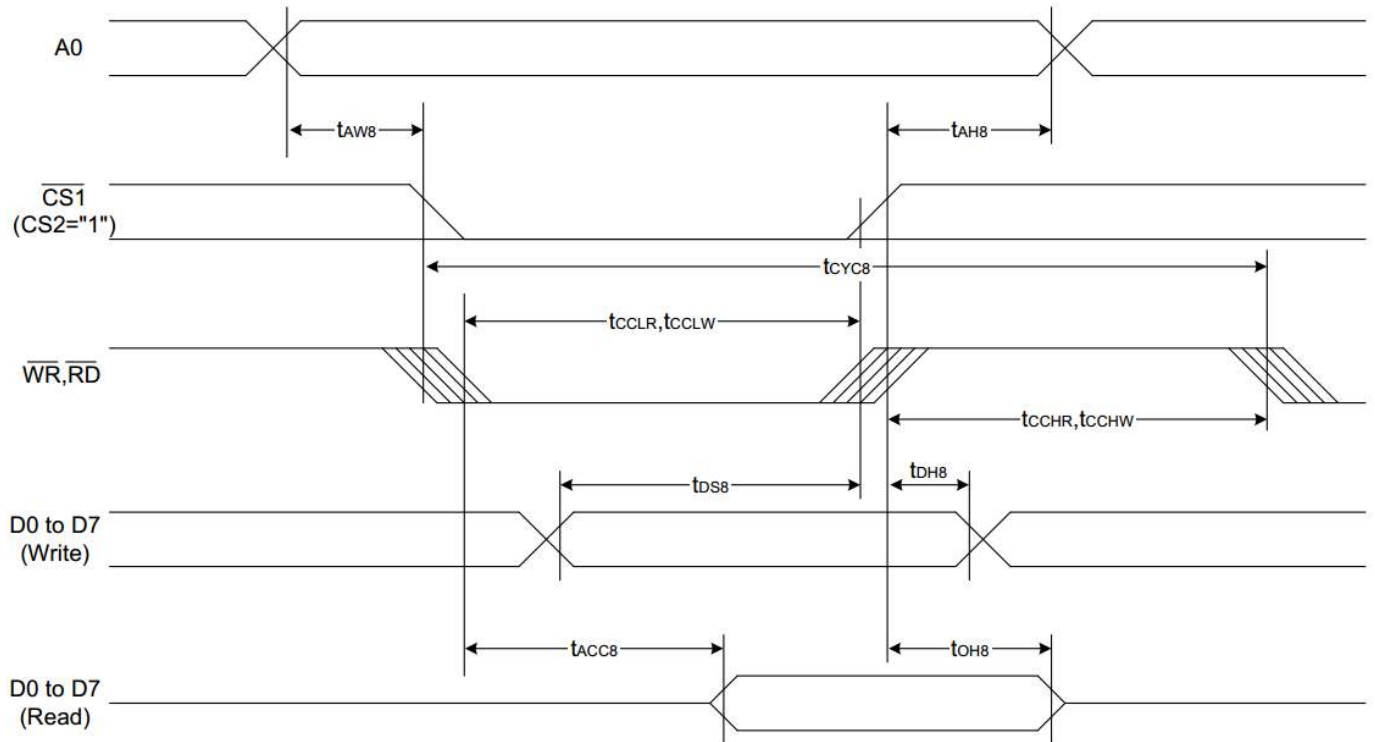

( $V_{DD} = 3.3V$ ,  $T_a = -30$  to  $85^{\circ}C$ )

Item	Signal	Symbol	Condition	Rating		Units
				Min.	Max.	
Address hold time	A0	tAH8		0	—	Ns
Address setup time		tAW8		0	—	
System cycle time		tCYC8		240	—	
Enable L pulse width (WRITE)	WR	tcCLW		80	—	
Enable H pulse width (WRITE)		tcCHW		80	—	
Enable L pulse width (READ)	RD	tcCLR		140	—	
Enable H pulse width (READ)		tcCHR		80	—	
WRITE Data setup time	D0 to D7	tDS8		40	—	
WRITE Address hold time		tDH8		0	—	
READ access time		tACC8	CL = 100 pF	—	70	
READ Output disable time		tOH8	CL = 100 pF	5	50	



## System Bus Read/Write Characteristics 2 (For the 6800 Series MPU)

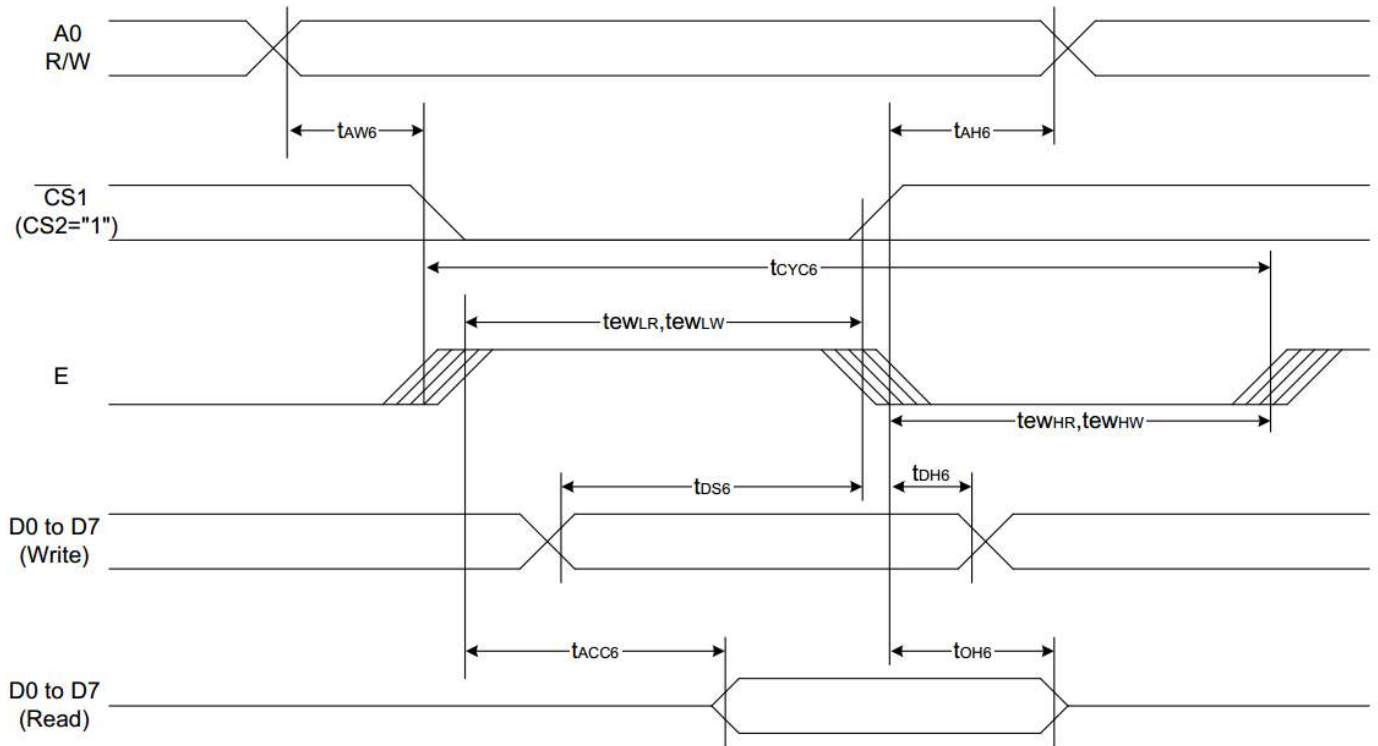

( $V_{DD} = 3.3V, T_a = -30 \text{ to } 85^\circ\text{C}$ )

Item	Signal	Symbol	Condition	Rating		Units
				Min.	Max.	
Address hold time	A0	$t_{AH6}$		0	—	ns
Address setup time		$t_{AW6}$		0	—	
System cycle time		$t_{CYC6}$		240	—	
Enable L pulse width (WRITE)	WR	$t_{EHLW}$		80	—	
Enable H pulse width (WRITE)		$t_{EHW}$		80	—	
Enable L pulse width (READ)	RD	$t_{EHLR}$		80	—	
Enable H pulse width (READ)		$t_{EHR}$		140	—	
WRITE Data setup time	D0 to D7	$t_{DS6}$		40	—	
WRITE Address hold time		$t_{DH6}$		0	—	
READ access time		$t_{ACC6}$	$C_L = 100 \text{ pF}$	—	70	
READ Output disable time		$t_{OH6}$	$C_L = 100 \text{ pF}$	5	50	

## The 4-line SPI Interface

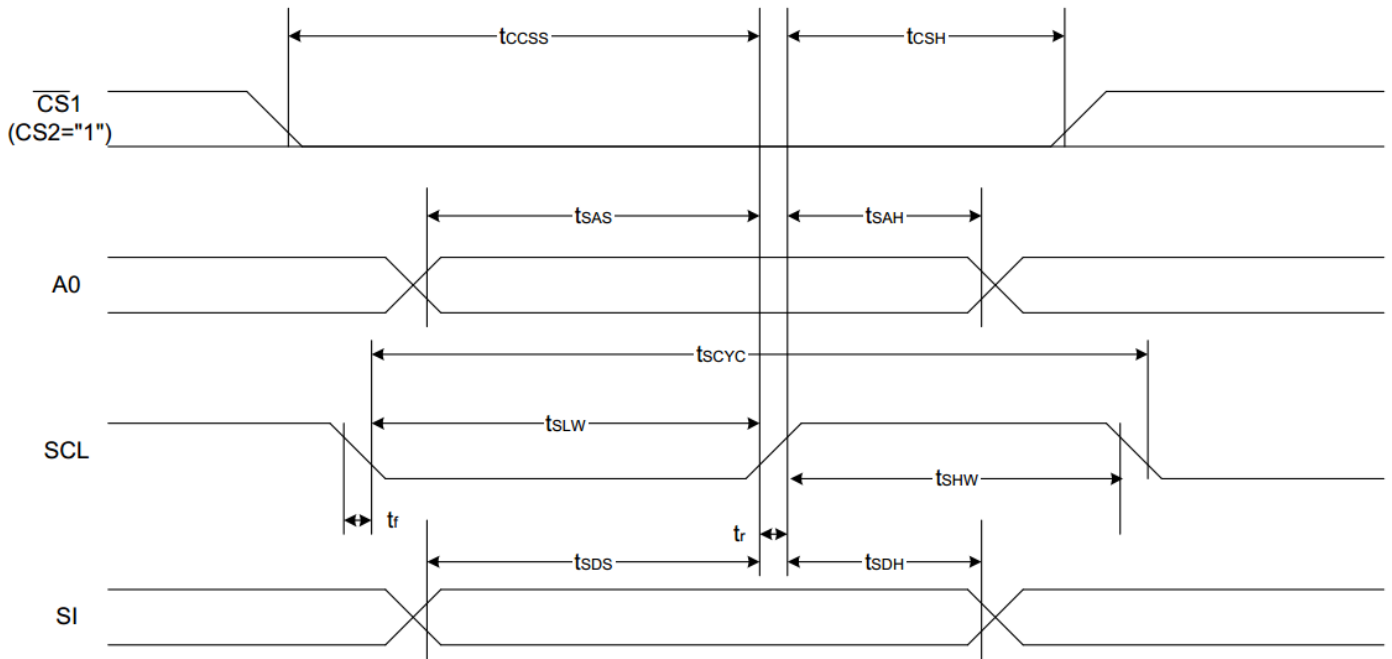

( $V_{\text{DD}} = 3.3\text{V}$ ,  $T_{\text{a}} = -30$  to  $85^{\circ}\text{C}$ )

Item	Signal	Symbol	Condition	Rating		Units
				Min.	Max.	
4-line SPI Clock Period	SCL	$T_{\text{scyc}}$		50	—	ns
SCL "H" pulse width		$T_{\text{shw}}$		25	—	
SCL "L" pulse width		$T_{\text{slw}}$		25	—	
Address setup time	A0	$T_{\text{sas}}$		20	—	
Address hold time		$T_{\text{sah}}$		10	—	
Data setup time	SI	$T_{\text{sds}}$		20	—	
Data hold time		$T_{\text{sdh}}$		10	—	
CS-SCL time	CS	$T_{\text{css}}$		20	—	
CS-SCL time		$T_{\text{csh}}$		40	—	

## Example Initialization Program

```
void comm_out(unsigned int c)
{
    CS1 = 0;           //Active Low
    AO = 0;           //LOW = instruction
    delay(1);
    WRT = 0;          // /WR in 8080 mode; R/W in 6800 mode
    P1 = c;
    delay(1);
    WRT = 1;          // /WR in 8080 mode; R/W in 6800 mode
    CS1 = 1;          //inactive
    delay(5);
}

void data_out(unsigned int d)
{
    CS1 = 0;           //Active Low
    AO = 1;           //High = Data
    delay(1);
    WRT = 0;
    //RDD = 1;
    P1 = d;
    delay(1);
    WRT = 1;
    CS1 = 1;          //inactive
}

void init()
{
    RDD = 1;          // /RD in 8080 mode; E in 6800 mode
    WRT = 1;          // /WR in 8080 mode; R/W in 6800 mode
    CS1 = 0;
    RST = 1;          // /RST in 8080 mode; /RES in 6800 mode
    RST = 0;          // /RST in 8080 mode; /RES in 6800 mode
    delay(2);
    RST = 1;          // /RST in 8080 mode; /RES in 6800 mode
    delay(2);
    comm_out(0xA2);   //added 1/9 bias

    comm_out(0xA0);   //ADC segment driver direction (AO=Normal)
    comm_out(0xC8);   //added
    comm_out(0xC0);   //COM output scan direction (C0= Normal)
    comm_out(0x40);   //Operating Mode
    delay(0);
    comm_out(0x25);   //resistor ratio
    delay(0);

    comm_out(0x81);   //electronic volume mode set
    delay(0);
    comm_out(0x19);   //electronic volume register set
    delay(0);
    comm_out(0x2F);   //power control set
    delay(0);
    comm_out(0xAF);   //display ON/OFF - set to ON
}
```

# Packing Procedure

## 1. Packing Materials

NO.	Item	Dimensions (LxWxH) (mm)	Quantity
1	Tray	366x296x21.1	15
2	Box	382x310x165	105
3	Carton	400x321x363	210

## 2. Packing Method

### A. Place display on the tray & Rotate Stacked trays by 180°

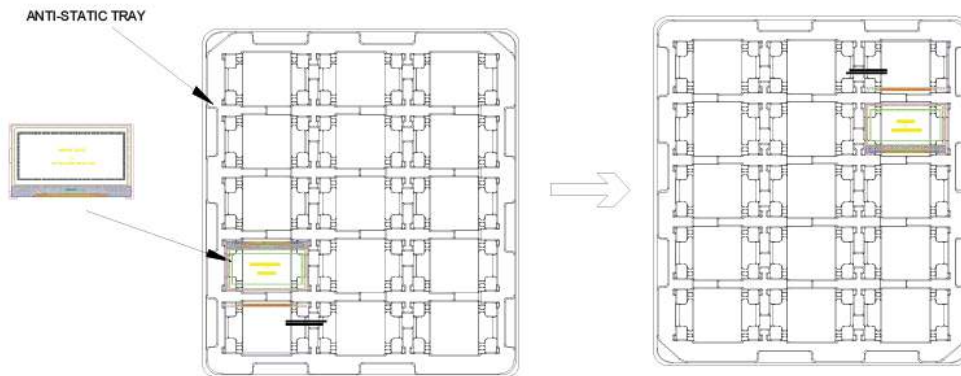

### B.

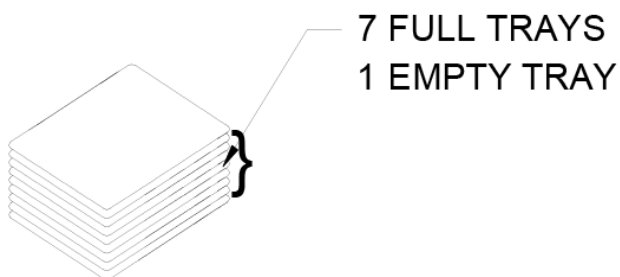

### C.

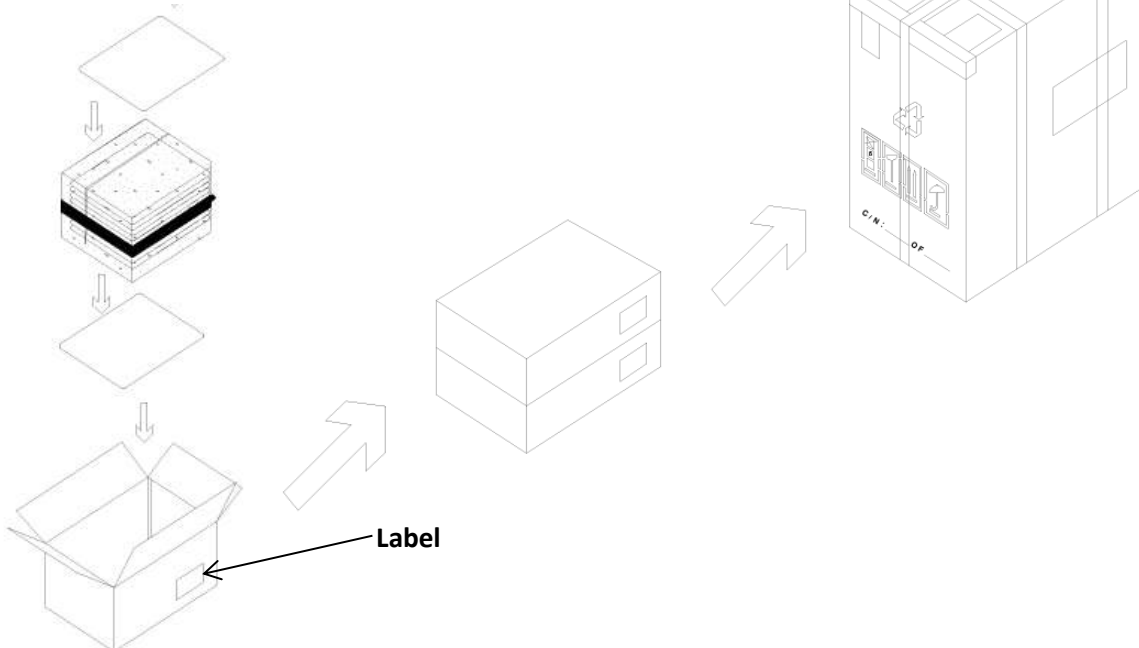

## Quality Information

Test Item	Content of Test	Test Condition	Note
High Temperature storage	Endurance test applying the high storage temperature for a long time.	+80°C , 96hrs	2
Low Temperature storage	Endurance test applying the low storage temperature for a long time.	-30°C , 96hrs	1,2
High Temperature Operation	Endurance test applying the electric stress (voltage & current) and the high thermal stress for a long time.	+70°C 96hrs	2
Low Temperature Operation	Endurance test applying the electric stress (voltage & current) and the low thermal stress for a long time.	-20°C , 96hrs	1,2
High Temperature / Humidity Operation	Endurance test applying the electric stress (voltage & current) and the high thermal with high humidity stress for a long time.	+60°C , 90% RH , 96hrs	1,2
Thermal Shock resistance	Endurance test applying the electric stress (voltage & current) during a cycle of low and high thermal stress.	-0°C,30min -> 25°C,5min -> 50°C,30min = 1 cycle 10 cycles	
Vibration test	Endurance test applying vibration to simulate transportation and use.	10-55Hz , 1.5mm amplitude. 60 sec in each of 3 directions X,Y,Z For 15 minutes	3
Static electricity test	Endurance test applying electric static discharge.	VS=±8kV Air, ±4kV Touch Five Times	

**Note 1:** No condensation to be observed.

**Note 2:** Conducted after 4 hours of storage at 25°C, 0%RH.

**Note 3:** Test performed on product itself, not inside a container.

## Precautions for using LCDs/LCMs

See Precautions at [www.newhavendisplay.com/specs/precautions.pdf](http://www.newhavendisplay.com/specs/precautions.pdf)

## Warranty Information and Terms & Conditions

[http://www.newhavendisplay.com/index.php?main\\_page=terms](http://www.newhavendisplay.com/index.php?main_page=terms)