



# PIC32 WFI32E

---

---

## PIC32 WFI32E Curiosity Board User's Guide

---

---

### Introduction

---

The PIC32 WFI32E Curiosity Board enables the user to evaluate and demonstrate the functionality of the PIC32MZ1025W104 System-on-Chip (SoC) and WFI32E01 module. This board is a modular development board that supports rapid prototyping using on-chip microcontroller (MCU) peripherals. This board offers integrated programming/debugging features using PICKit™ On- Board (PKOB3) debugger, and requires only a micro-USB cable to power-up and program the board. The PIC32 WFI32E Curiosity Board supports a variety of applications such as Internet of Things (IoT) and other Wi-Fi®-enabled applications.

### Features

---

- Certified WFI32E01 Module Mounted on the WFI32E01 Carrier Board
- mikroBUS™ Socket to Expand Functionality using MikroElektronika Click Boards
- Support for Multiple Microchip Ethernet PHY Daughter Boards
- Two User LEDs
- One User Configurable Switch
- One Reset Switch
- One GPIO Expansion Header
- On-board Temperature Sensor
- 20-Pin XPRO Header
- 32-Mb External SPI Flash Memory
- In-Circuit Serial Programming™ (ICSP) Header for External Debugger, such as MPLAB® ICD 4, MPLAB PICKit 4 and MPLAB Snap

## Table of Contents

Introduction.....	1
Features.....	1
1. Quick References.....	4
1.1. Reference Documentation.....	4
1.2. Hardware Prerequisites.....	4
1.3. Software Prerequisites.....	4
1.4. Acronyms/Abbreviations.....	4
2. Kit Overview.....	6
2.1. Kit Contents.....	6
3. Hardware.....	7
3.1. Power Supply.....	7
3.2. Debugger/Programmer Selection.....	8
3.3. ICSP Header.....	9
3.4. USB Connectivity.....	10
3.5. mikroBUS Socket.....	10
3.6. Switches.....	11
3.7. LEDs.....	11
3.8. Ethernet Interface.....	12
3.9. GPIO Header.....	13
3.10. XPRO Header.....	14
3.11. Temperature Sensor.....	15
3.12. Serial Flash.....	16
3.13. Carrier Board Interface.....	16
4. PIC32 WFI32E Curiosity Board Out of Box Demo.....	22
5. Appendix A: WFI32E01 Carrier Board.....	23
6. Appendix B: Reference Circuit.....	24
6.1. PIC32 WFI32E Curiosity Board Reference Schematics.....	24
6.2. PIC32 WFI32E Curiosity Board Bill of Materials.....	28
6.3. WFI32E01 Carrier Board Bill of Materials.....	31
7. Regulatory Approval.....	33
7.1. United States.....	33
7.2. Canada.....	33
7.3. Europe.....	34
8. Document Revision History.....	35
The Microchip Website.....	36
Product Change Notification Service.....	36
Customer Support.....	36

Microchip Devices Code Protection Feature.....	36
Legal Notice.....	37
Trademarks.....	37
Quality Management System.....	38
Worldwide Sales and Service.....	39

## 1. Quick References

### 1.1 Reference Documentation

For further details, refer to the following:

- *PIC32MZ1025W104 MCU and WFI32E01 Module with Wi-Fi® and Hardware-based Security Accelerator Data Sheet* ([DS70005425](#))
- *PIC32MZ W1 Software User's Guide* ([DS50003034](#))
- *PIC32MZ1025W104 MCU and WFI32E01 Module with Wi-Fi® and Hardware-based Security Accelerator Errata* ([DS80000912](#))
- *MPLAB® XC32 C/C++ Compiler User's Guide* ([DS50001686](#))
- *MPLAB® X IDE User's Guide* ([DS50002027](#))
- *MPLAB® Snap In-Circuit Debugger Information Sheet* ([DS50002787](#))
- *Universal Serial Bus Specification and Associated Documents* ([www.usb.org/](http://www.usb.org/))
- *mikroBUS™ Specification* ([www.mikroe.com/mikrobus](http://www.mikroe.com/mikrobus))

### 1.2 Hardware Prerequisites

- PIC32 WFI32E Curiosity Board kit
- Any of the following in-circuit debugger or programmers:
  - MPLAB Snap
  - MPLAB PICKit 4
  - MPLAB ICD 4

### 1.3 Software Prerequisites

- MPLAB Integrated Development Environment (MPLAB X IDE) tool (version 5.35 or later)
- MPLAB XC32 compiler (version 2.40 or later)
- MPLAB Snap ([www.microchip.com/developmenttools/ProductDetails/PartNO/PG164100](http://www.microchip.com/developmenttools/ProductDetails/PartNO/PG164100))
- Released OOB demo ([github.com/MicrochipTech/PIC32MZW1\\_Curiosity\\_OOB](https://github.com/MicrochipTech/PIC32MZW1_Curiosity_OOB))

### 1.4 Acronyms/Abbreviations

**Table 1-1. Acronyms/Abbreviations**

Acronyms	Abbreviations
ADC	Analog-to-Digital Converter
BOM	Bill of Material
CVD	Capacitive Voltage Divider
GPIO	General Purpose Input Output
I <sup>2</sup> C	Inter-Integrated Circuit
ICD	In-Circuit Debugger
ICSP	In-Circuit Serial Programming
IoT	Internet of Things
JTAG	Joint Test Action Group

.....continued	
Acronyms	Abbreviations
LDO	Low-Dropout
LED	Light Emitting Diode
MCU	Microcontroller
NC	Not Connected
OOB	Out of Box
OTG	On-The-Go
PCB	Printed Circuit Board
PKOB	PICKit On-Board
PPS	Peripheral Pin Select
PWM	Pulse Width Modulation
RMII	Reduced Media Independent Interface
RTCC	Real Time Clock and Calendar
RX	Receiver
SCL	Serial Clock
SDA	Serial Data
SMD	Surface Mount
SoC	System-on-Chip
SPI	Serial Peripheral Interface
TX	Transmitter
UART	Universal Asynchronous Receiver-Transmitter
USB	Universal Serial Bus

## 2. Kit Overview

The PIC32 WFI32E Curiosity Board contains a WFI32E01 module mounted on the carrier board. All the signals from the module are brought onto the Curiosity board, where they are connected to on-board peripherals or are terminated onto headers for rapid prototyping or evaluation.

**Figure 2-1. PIC32 WFI32E Curiosity Board (EV12F11A)**

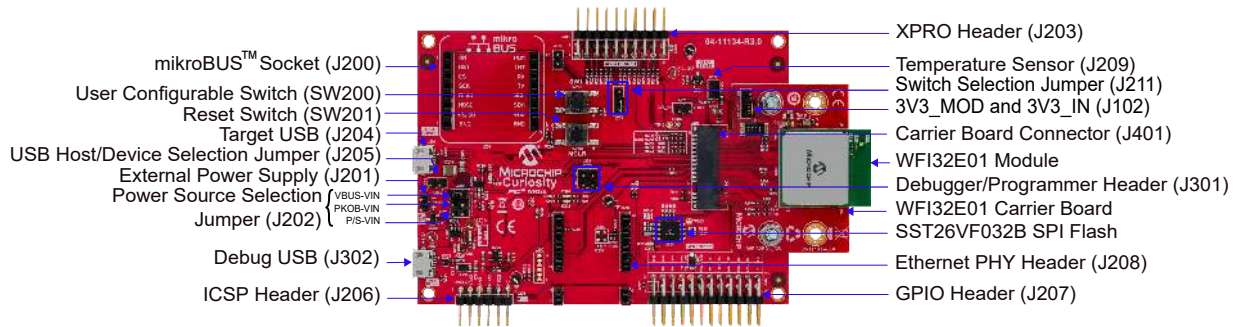

### 2.1 Kit Contents

The PIC32 WFI32E Curiosity Board kit contains the following:

- PIC32 WFI32E Curiosity Board that contains a WFI32E01PC module mounted on a WFI32E01 carrier board
- Type-A male to Micro-B USB cable

**Note:** If any of the above items are missing in the kit, go to [support.microchip.com](http://support.microchip.com) or contact your local Microchip sales office. A list of Microchip office for sales and services is provided on the last page of this document.

### 3. Hardware

This chapter describes the hardware features of the PIC32 WFI32E Curiosity Board.

Figure 3-1. PIC32 WFI32E Curiosity Board Block Diagram

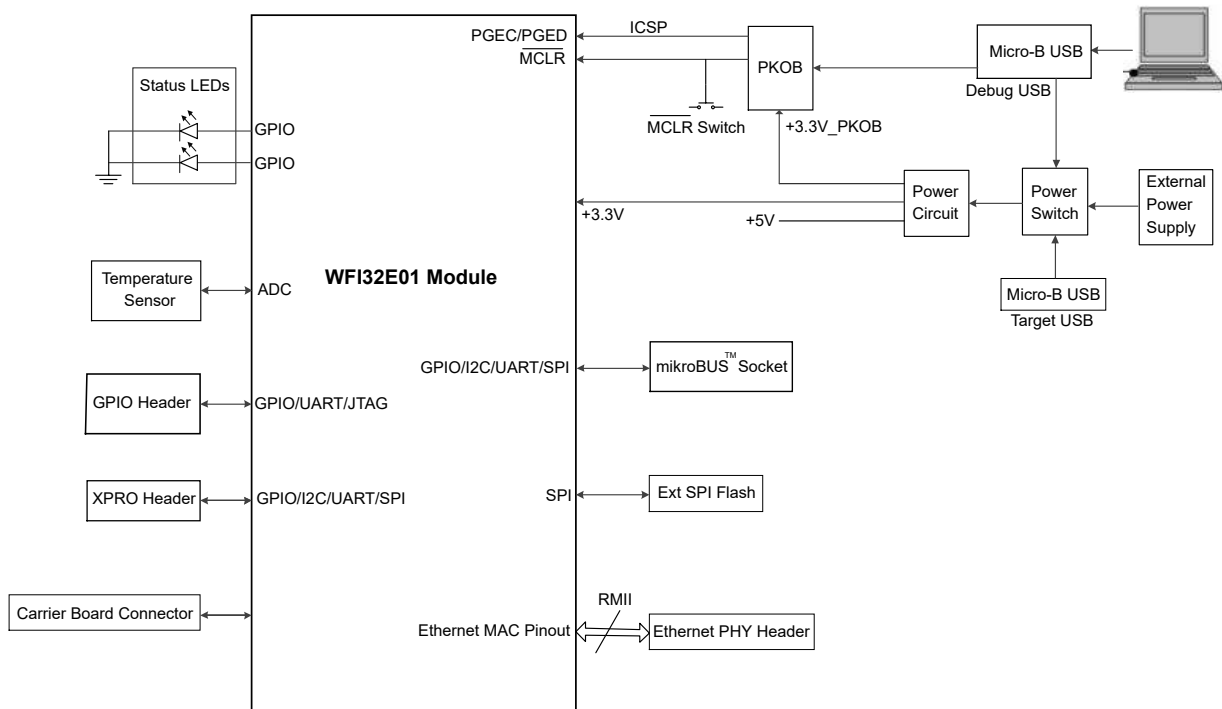

#### 3.1 Power Supply

The PIC32 WFI32E Curiosity Board can be powered using any of the following sources:

- External 5V (J201)
- PKOB3 micro-B USB (J302)
- Target VBUS micro-B (J204)

The following table lists the power supply source details and its jumper positions.

Table 3-1. Power Supply Sources

Power Input	Description	Jumper Position (J202) <sup>(1)</sup>
External 5V (J201)	Connect the Curiosity board to an external 5V power supply	P/S-VIN (2-1)
PKOB3 micro-B USB (J302)	Connect the Type-A male to micro-B USB cable to the USB debug port for power supply	PKOB-VIN (4-3)
Target VBUS micro-B (J204)	Connect the Type-A male to micro-B USB cable to the USB power port for power supply	VBUS-VIN (6-5)

**Note:**

1. J202 in Figure 2-1.

The following figure illustrates the jumper positions for powering the Curiosity board.

**Figure 3-2. Jumper Configuration for Power Input**

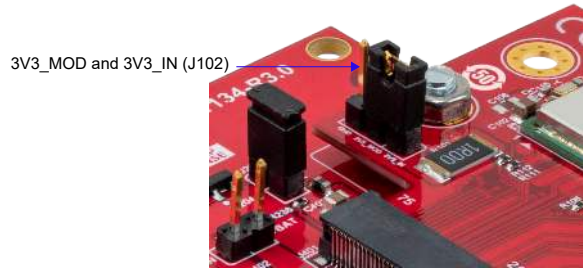

**Note:** Ensure that the 3V3\_MOD and 3V3\_IN of **J102** are connected on the WFI32E01 carrier board.

Use the **J202** jumper to select the voltage source for the Curiosity board. The MCP1727 voltage regulator generates a +3.3V power supply for the MCU. Connect the PKOB debugger to a host PC. Turn on the power supply (+3.3V and +5V) to the Curiosity board via a power switch (MIC2005A) to drive the ENABLE signal to high.

**Figure 3-3. Power Tree Diagram**

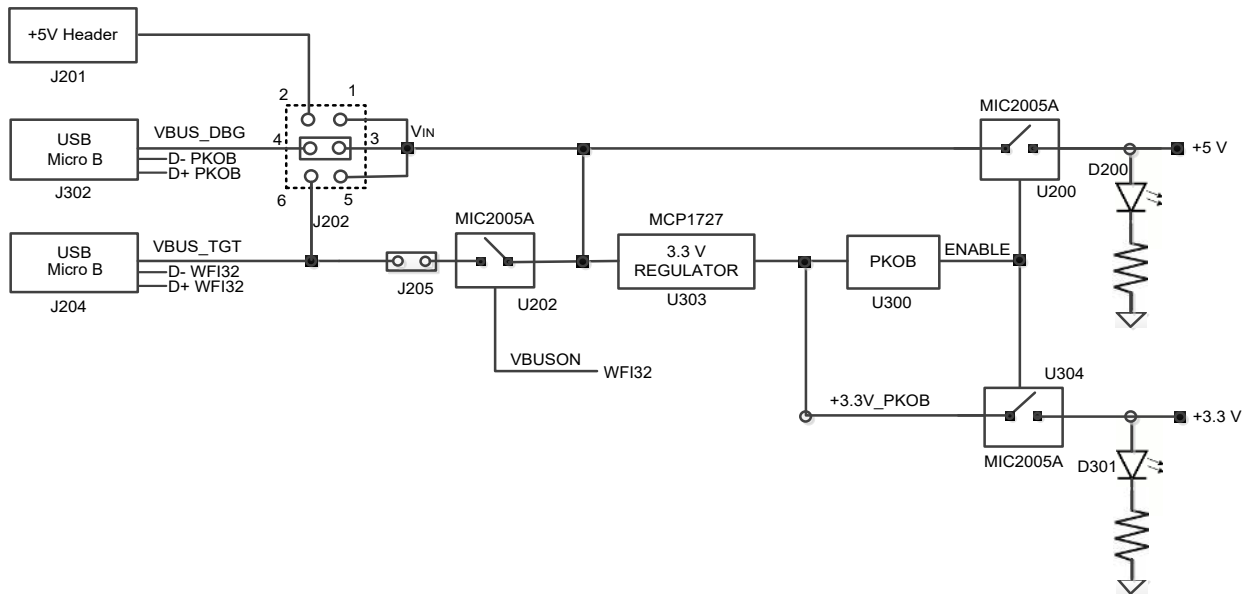

## 3.2 Debugger/Programmer Selection

By default, the external debugger is connected to the programming pins (PGEC2 and PGED2) of the WFI32E01 module. The following table lists the details of the debugger/programmer selection using the **J301** header.



**Important:** Use an external debugger such as MPLAB ICD 4, MPLAB PICKit 4 or MPLAB Snap for the best programming and debugging experience.

The PIC32 WFI32E Curiosity Board has an on-board debugger (PKOB3) based on the PIC24FJ256GB106 MCU. The on-board debugger enables the user to power, program and debug through the micro-B USB connector (**J302**).



**Table 3-2. Debugger/Programmer Selection**

Header Position (J301) <sup>(1)</sup>	Debugger Used	Description
Pins 1-2 and 3-4 shorted	On-board	Selects the on-board debugger
Pins 1-2 and 3-4 open	External	Selects the external debugger (for more details, refer to <a href="#">3.3 ICSP Header</a> )

**Note:**

1. J301 in [Figure 2-1](#).

### 3.3 ICSP Header

The ICSP header (J206) is a standard 6-pin staggered header. It allows in-circuit emulation and debugging using Microchip's in-circuit emulator tools and it allows direct programming of the WFI32E01 module. The ICSP header supports external debuggers, such as MPLAB ICD 4, MPLAB PICKit 4 and MPLAB Snap. Use the standard ICSP header to connect an MPLAB programmer or debugger to the PIC32 WFI32E Curiosity Board. The following figure illustrates the connection between the ICSP header, external debuggers and the PIC32 WFI32E Curiosity Board.

**Figure 3-4. Connection Diagram**

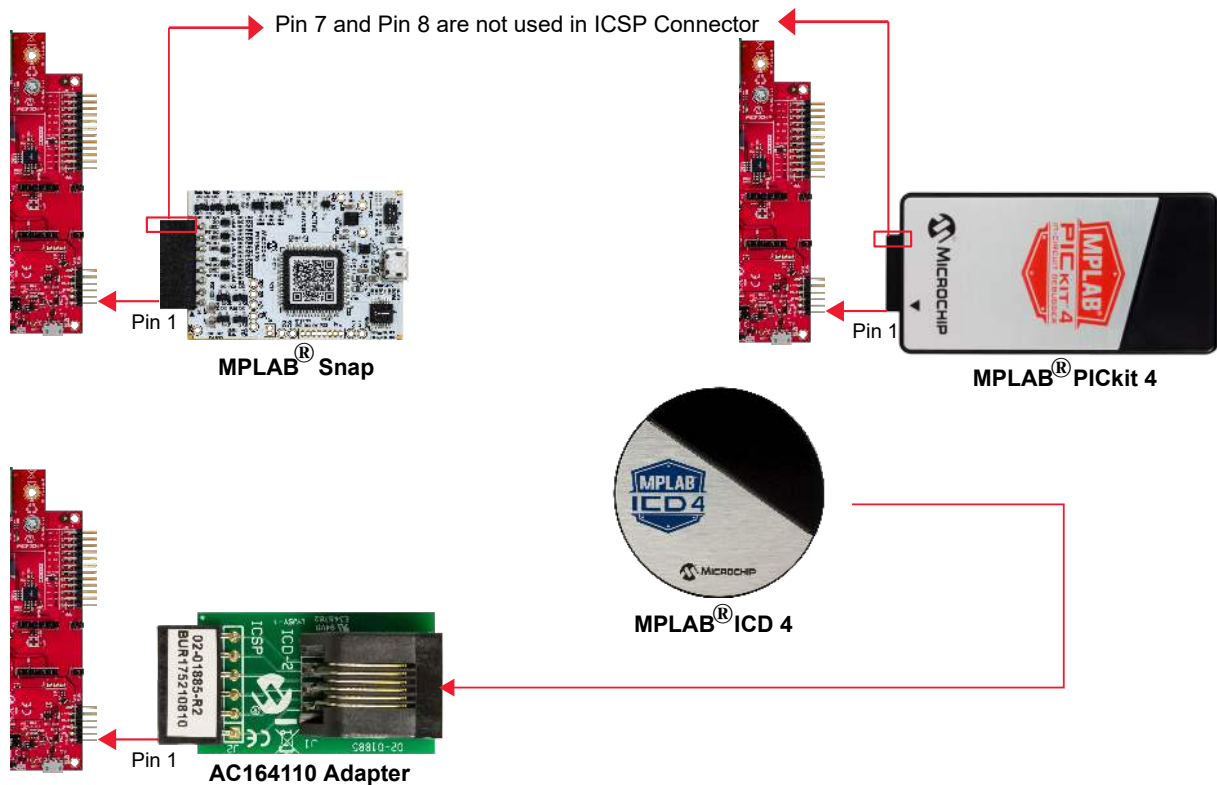

The following table provides the pin details and descriptions of the ICSP header.

**Table 3-3. ICSP Header Description**

Pin Number	Pin on ICSP Header	Pin Description of ICSP Header	Pin on WFI32E01 Module <sup>(1)</sup>
1	MCLR	Reset pin	MCLR
2	3V3	3.3V power supply	+3V3

.....continued

Pin Number	Pin on ICSP Header	Pin Description of ICSP Header	Pin on WFI32E01 Module <sup>(1)</sup>
3	GND	Ground	GND
4	PGD	ICSP™ programming data	PGD2/AN5/CVD5/CVDR5/CVDT2/RTCC/ RPB5
5	PGC	ICSP™ programming clock	PGC2/AN4/CVD4/CVDR4/CVDT3/ RPB4/RB4
6	NC	Not connected	NC

**Notes:**

- For more details on the WFI32E01 pins, refer to the *PIC32MZ1025W104 MCU and WFI32E01 Module with Wi-Fi® and Hardware-based Security Accelerator Data Sheet (DS70005425)*.
- Use an external debugger such as MPLAB ICD 4 or MPLAB Snap for the best programming and debugging experience.

### 3.4 USB Connectivity

The WFI32E01 module has an integrated full-speed USB peripheral. This feature enables the user to implement USB functionality through the micro-AB USB connector ([J204](#)) on the PIC32 WFI32E Curiosity Board. Connect the board using any one of these modes:

- Device mode:
  - Connect the host PC to the target USB connector ([J204](#)) using a USB Type-A male to micro-B male USB cable.
  - Use the [J301](#) jumper to select the required power source for the board.  
**Note:** Do not place the jumper on the [J205](#) connector.
- Host mode:
  - Connect the USB device to the target USB connector ([J302](#)) using a USB Type-A female to micro-B male USB cable.  
**Note:** A micro-B male USB cable is not available in the kit.
  - Place a jumper in the [J205](#) header to drive the V<sub>BUS</sub> line in the Host mode.
  - Use the [J301](#) jumper to select the power source either from the debug USB connector or the external 5V input.

### 3.5 mikroBUS Socket

A mikroBUS socket ([J200](#)) expands the functionality of the PIC32 WFI32E Curiosity Board using the MikroElektronika click adapter boards. The mikroBUS connector consists of two 1 x 8 female headers with Serial Peripheral Interface (SPI), Inter-Integrated Circuit (I<sup>2</sup>C), Universal Asynchronous Receiver-Transmitter (UART), Reset (GPIO), Pulse Width Modulation (PWM), analog and interrupt lines, as well, as 3.3V, 5V and ground power lines. The following table describes the pinout details of the mikroBUS socket.

**Table 3-4. mikroBUS Socket Pinout Details**

Pin Number	Pin on mikroBUS Socket	Pin Description of mikroBUS Socket	Pin on WFI32E01 Module <sup>(1)</sup>
1	AN	Analog input	AN14/ANN0/CVD14/CVDR14/RPA14/RA14
2	$\overline{\text{RST}}$	Reset	TMS/AN6/CVD6/CVDR6/RPB6/RB6
3	$\overline{\text{CS}}$	SPI Chip Select	PTA_BT_PRIO/RPK6/RK6

.....continued

Pin Number	Pin on mikroBUS Socket	Pin Description of mikroBUS Socket	Pin on WFI32E01 Module <sup>(1)</sup>
4	SCK	SPI Clock	SCK2/RPA11/RA11
5	MISO	SPI Master Input Slave Output	BT_CLK_OUT/RPK4/RK4
6	MOSI	SPI Master Input Slave Input	PTA_BT_ACTIVE/RPK7/RK7
7	+3.3V	3.3V power	+3.3V
8	GND	Ground	GND
9	GND	Ground	GND
10	+5V	5V power	+5V
11	SDA	I2C Data	SDA1/RPA5/RA5
12	SCL	I2C Clock	SCL1/RPA4/RA4
13	TX	UART transmit	TDO/AN7/CVD7/CVDR7/RPB7/RB7
14	RX	UART receive	TDI/PGD4/AN9/CVD9/CVDR9/RPB9/RB9
15	$\overline{\text{INT}}$	Hardware interrupt	BT_CLK_OUT/RPK4/RK4
16	PWM	PWM output	ANA0/RPB12/RB12

**Notes:**

- For more details on the WFI32E01 pins, refer to the *PIC32MZ1025W104 MCU and WFI32E01 Module with Wi-Fi® and Hardware-based Security Accelerator Data Sheet (DS70005425)*.
- The SPI interface on the click board can operate up to 12.5 MHz and the WFI32E01 module supports up to 20 MHz.

### 3.6 Switches

The following switches are available on the PIC32 WFI32E Curiosity Board:

- User-configurable switch ([SW200](#))
- Reset switch ([SW201](#)) – Connected with  $\overline{\text{MCLR}}$  signal of the WFI32E01 module

In the Idle state, the level of the user-configurable switch is pulled high (+3.3V) and, when the switch is pressed, it drives the I/O line to low (GND).

**Table 3-5. Switches Description**

Switch Name	Pin on WFI32E01 Module	Description
SW1	AN17/CVD17/CVDR17/INT0/RPA10/RA10	User configurable switch ( <a href="#">SW200</a> )
$\overline{\text{MCLR}}$	$\overline{\text{MCLR}}$	Reset switch ( <a href="#">SW201</a> )

**Note:** By default, the [SW200](#) switch is connected to the switch input. Use the [J211](#) jumper to configure the board to the switch or external interrupt.

### 3.7 LEDs

The on-board LEDs are categorized into two types:

- Power LEDs

- Vin Green (D201)
- 5V Green (D200)
- +3.3V Green (D301)
- LEDs related to the WFI32E01 module:
  - Red LED (D202)
  - Green LED (D204)

The following table lists the LEDs that can be turned ON or OFF using the connected GPIO pins:

**Table 3-6. LEDs Description**

Pin on WFI32E01 Module	Description	Function
RF_FE_4/RPK1/RK1	RF front-end control/remappable peripheral/PORTK digital I/O	Red LED (D202)
RF_FE_2/RPK3/RK3	RF front-end control/remappable peripheral/PORTK digital I/O	Green LED (D204)

### 3.8 Ethernet Interface

The PIC32 WFI32E Curiosity Board includes headers to mount different Ethernet PHY daughter boards to implement a complete Ethernet node for networking. This user guide uses the LAN8720A PHY daughter board (AC320004-3) as an example.

**Table 3-7. Ethernet PHY Daughter Board**

Daughter Board	Part Number
LAN8720A PHY daughter board	<a href="#">AC320004-3</a>

**Note:** Ethernet PHY daughter boards are not verified for regulatory compliance.

The Microchip LAN8720A PHY daughter board is populated with a small footprint RMII 10/100 Ethernet transceiver (LAN8720A). This daughter board enables Ethernet communication with a variety of Microchip development boards. The following table lists the pin details and descriptions of the Ethernet PHY daughter board.

**Table 3-8. Ethernet PHY Daughter Board Header Pin Description**

Pin Number	Pin on Ethernet PHY Daughter Board	Pin Description of Ethernet PHY Daughter Board	Pin on WFI32E01 Module <sup>(1)(2)</sup>
1	TX_EN	Ethernet Transmit Enable	CVDT11/ETXEN/RPC13/RC13
2	TXD0	Ethernet Transmit Data 0	CVDT13/ETXD0/RPC15/RC15
3	TXD1	Ethernet Transmit Data 1	CVDT12/ETXD1/RPC14/RC14
4	NC	Not connected	NC
5	NC	Not connected	NC
6	GND	Ground	GND
7	XTALI	Clock output	NC
8	CLK_IN	Clock input	ETH_CLK_OUT/CVDT10/RPC12/RC12
9	GND	Ground	GND
10	+3V3	Input power supply	3V3
11	NC	Not connected	NC

.....continued

Pin Number	Pin on Ethernet PHY Daughter Board	Pin Description of Ethernet PHY Daughter Board	Pin on WFI32E01 Module <sup>(1)(2)</sup>
12	NC	Not connected	NC
13	NC	Not connected	NC
14	NC	Not connected	NC
15	RXD1	Ethernet Receive Data 1	CVDT8/ERXD1/RPC10/RC10
16	RXD0	Ethernet Receive Data 0	CVDT9/ERXD0/RPC11/RC11
17	RX_ER	Ethernet Receive Error	CVDT7/ERXERR/PC9/RC9
18	CRS_DV	Ethernet Rx Data Valid Input	CVDT14/ERXDV/RPK12/RK12
19	MDC	Ethernet Management Data Clock Output	CVDT16/EMDC/RPK14/RK14
20	MDIO	Ethernet Management Data Input Output	CVDT15/EMDIO/RPK13/RK13
21	$\overline{\text{INT}}$	Interrupt output	PTA_BT_PPIO/RPK6/RK6
22	$\overline{\text{RST}}$	System Reset	AN14/ANN0/CVD14/CVDR14/RPA14/RA14
23	NC	Not connected	NC
24	NC	Not connected	NC

**Notes:**

1. These are Peripheral Pin Select (PPS) pins and can be configured for any of the supported peripheral functions based on the end user application.
2. For more details on the WFI32E01 pins, refer to the *PIC32MZ1025W104 MCU and WFI32E01 Module with Wi-Fi® and Hardware-based Security Accelerator Data Sheet (DS70005425)*.

### 3.9 GPIO Header

The PIC32 WFI32E Curiosity Board provides a header ([J207](#)) to access the unused WFI32E01 GPIO pins. The following table lists the details of the GPIO header.

**Table 3-9. GPIO Header Description**

Pin Number	Pin on GPIO Header	Pin Description of GPIO Header	Pin on WFI32E01 Module <sup>(1)(2)</sup>
1	GND	Ground	GND
2	GND	Ground	GND
3	TDI	JTAG test data	TDI/PGD4/AN9/CVD9/CVDR9/RPB9/RB9
4	GND	Ground	GND
5	TDO	JTAG test data output	TDO/AN7/CVD7/CVDR7/RPB7/RB7
6	GND	Ground	GND
7	TMS	JTAG Test mode select input	TMS/AN6/CVD6/CVDR6/RPB6/RB6
8	GND	Ground	GND

.....continued

Pin Number	Pin on GPIO Header	Pin Description of GPIO Header	Pin on WFI32E01 Module <sup>(1)(2)</sup>
9	TCK	JTAG test clock	TCK/PGC4/AN8/CVD8/CVDR8/RPB8/RB8
10	GND	Ground	GND
11	$\overline{\text{MCLR}}$	Reset pin	$\overline{\text{MCLR}}$
12	NC	Not connected	NC
13	U1RX	UART1 receive input	U1RX
14	NC	Not connected	NC
15	+3.3	VCC	+3.3V
16	NC	Not connected	NC
17	GND	Ground	GND
18	NC	Not connected	NC
19	NC	Not connected	NC
20	NC	Not connected	NC
21	NC	Not connected	NC
22	NC	Not connected	NC
23	U1TX	UART1 transmit output	U1TX
24	NC	Not connected	NC

**Notes:**

1. These are PPS pins and can be configured for any of the supported peripheral functions based on the end user application.
2. For more details on the WFI32E01 pins, refer to the *PIC32MZ1025W104 MCU and WFI32E01 Module with Wi-Fi® and Hardware-based Security Accelerator Data Sheet (DS70005425)*.

### 3.10 XPRO Header

The PIC32 WFI32E Curiosity Board provides the XPRO header ([J203](#)) to have a pin-to-pin compatibility for XPRO boards. The following table describes the details of the XPRO header pin.

**Table 3-10. XPRO Header Pin Description**

Pin Number	Pin on XPRO Header	Pin Description of XPRO Header	Pin on WFI32E01 Module <sup>(1)(2)</sup>
1	ID <sup>(4)</sup>	Communication line to the ID chip on an extension board	PTA_BT_PRI0/RPK6/RK6
2	GND	Ground	GND
3	ADC(+)	Analog-to-Digital converter, alternatively positive part of differential ADC	TMS/AN6/CVD6/CVDR6/RPB6/RB6
4	ADC(-)	Analog-to-Digital converter, alternatively negative part of differential ADC	AN14/ANN0/CVD14/CVDR14/RPA14/RA14

.....continued

Pin Number	Pin on XPRO Header	Pin Description of XPRO Header	Pin on WFI32E01 Module <sup>(1)(2)</sup>
5	GPIO1	General purpose I/O	TCK/PGC4/AN8/CVD8/CVDR8/RPB8/RB8
6	GPIO2	General purpose I/O	PTA_BT_PRIOR/RPK6/RK6
7	PWM(+)	Pulse width modulation, alternatively positive part of differential PWM	ANA0/RPB12/RB12
8	PWM(-)	Pulse width modulation, alternatively negative part of differential PWM	USBID/AN2/CVD2/CVDR2/CVDT5/RPB2/RB2
9	IRQ/GPIO <sup>(5)</sup>	Interrupt request line and/or general purpose I/O	AN17/CVD17/CVDR17/INT0/RPA10/RA10
10	SPI_SS_B/GPIO	Slave select for SPI and/or general purpose I/O	PTA_BT_ACTIVE/RPK7/RK7
11	I2C_SDA	Data line for I2C interface	SDA1/RPA5/RA5
12	I2C_SCL	Clock line for I2C interface	SCL1/RPA4/RA4
13	UART_RX	Receiver line of target device UART	TDI/PGD4/AN9/CVD9/CVDR9/RPB9/RB9
14	UART_TX	Transmitter line of target device UART	TDO/AN7/CVD7/CVDR7/RPB7/RB7
15	SPI_SS_A	Slave select for SPI. This pin must be preferably unique	PTA_BT_ACTIVE/RPK7/RK7
16	SPI_MOSI	Master-out, slave-in line of serial peripheral interface	PTA_WLAN_ACTIVE/RPK5/RK5
17	SPI_MISO	Master-in, slave-out line of serial peripheral interface	BT_CLK_OUT/RPK4/RK4
18	SPI_SCK	Clock for serial peripheral interface	SCK2/RPA11/RA11
19	GND	Ground	GND
20	VCC	Power for extension board	VCC

### Notes:

1. These are PPS pins and can be configured for any of the supported peripheral functions based on the end user application.
2. For more details on the WFI32E01 pins, refer to the *PIC32MZ1025W104 MCU and WFI32E01 Module with Wi-Fi® and Hardware-based Security Accelerator Data Sheet (DS70005425)*.
3. The SPI2 interface on the XPRO board can operate up to 12.5 MHz, and the WFI32E01 module supports up to 20 MHz.
4. The JP200 jumper must be mounted on the J210 connector to use the ID feature.
5. The JP201 jumper must be mounted on the J211 connector pin2 and pin3 to use this feature.

## 3.11 Temperature Sensor

Connect an analog output from the temperature sensor (Microchip TC1047A, U204) to one of the analog pins (ANN1/CVD15/CVDR15/RPA13) of the module's ADC channel.

**Note:** Short the J209 jumper to enable the temperature sensor.

### 3.12 Serial Flash

The PIC32 WFI32E Curiosity Board has an on-board 32-Mb external SPI Flash ([SST26VF032B](#)) memory for storage of data. The following table describes the details of the serial Flash pin connection.

**Table 3-11. Serial Flash Pin Description**

Pin Number	Pin on Serial Flash (SST26VF032B)	Pin Description of Serial Flash	Pin on WFI32E01 Module <sup>(1)</sup>
1	$\overline{CE}$	Chip Enable	SPI1 $\overline{CS}$ /RPA1/RA1
2	SO	Serial Data Output for SPI mode	SDI1/RPC7/RC7
3	$\overline{WP}$	Write-Protect	Not Connected
4	VSS	Ground	GND
5	SI	Serial Data Input for SPI mode	SDO1/RPC8/RC8
6	SCK	Serial Clock	SCK1/RPC6/RC6
7	$\overline{HOLD}$	Hold	Not Connected
8	VDD	Input power supply	VDD

**Note:**

- For more details on the WFI32E01 pins, refer to the *PIC32MZ1025W104 MCU and WFI32E01 Module with Wi-Fi® and Hardware-based Security Accelerator Data Sheet* ([DS70005425](#)).

### 3.13 Carrier Board Interface

The WFI32E01 module is connected to the carrier board connector ([J401](#)). The following table describes the pinout details of the [J401](#) connector.

**Table 3-12. Carrier Board Interface Description**

Pin Number	Pin on Carrier Board	Pin Description on Carrier Board	Pin on WFI32E01 Module <sup>(1)(2)</sup>
1	$\overline{MCLR}$	Reset	$\overline{MCLR}$
2	PTA_WLAN_ACTIVE/RPK5	Wi-Fi® and Bluetooth® coexistence/remappable peripheral/PORTK digital I/O	PTA_WLAN_ACTIVE/RPK5/RK5
3	PTA_BT_PRIOR/RPK6	Wi-Fi and Bluetooth coexistence/remappable peripheral/PORTK digital I/O	PTA_BT_PRIOR/RPK6/RK6
4	PTA_BT_ACTIVE/RPK7	Wi-Fi and Bluetooth coexistence/remappable peripheral/PORTK digital I/O	PTA_BT_ACTIVE/RPK7/RK7
5	BT_CLK_OUT/RPK4	Bluetooth clock out (26 MHz)/remappable peripheral/PORTK digital I/O	BT_CLK_OUT/RPK4/RK4



.....continued

Pin Number	Pin on Carrier Board	Pin Description on Carrier Board	Pin on WFI32E01 Module <sup>(1)(2)</sup>
6	SDI1/RPC7	SPI1 serial data input/ remappable peripheral/ PORTC digital I/O	SDI1/RPC7/RC7
7	GND	Ground	GND
8	CVDT7/ERXERR/RPC9	ADC CVD controller TX output/Ethernet receive error input/remappable peripheral/PORTC digital I/O	CVDT7/ERXERR/RPC9/RC9
9	SDO1/RPC8	SPI1 serial data output/ remappable peripheral/ PORTC digital I/O	SDO1/RPC8/RC8
10	CVDT16/EMDC/RPK14	ADC CVD controller TX output/Ethernet management data clock output/remappable peripheral/PORTK digital I/O	CVDT16/EMDC/RPK14/RK14
11	SCK1/RPC6	SPI1 serial clock/ remappable peripheral/ PORTC digital I/O	SCK1/RPC6/RC6
12	NC	Not connected	NC
13	NC	Not connected	NC
14	NC	Not connected	NC
15	NC	Not connected	NC
16	NC	Not connected	NC
17	NC	Not connected	NC
18	NC	Not connected	NC
19	NC	Not connected	NC
20	CVDT15/EMDIO/RPK13	ADC CVD controller TX output/Ethernet management data bi- directional IO/remappable peripheral/PORTK digital I/O	CVDT15/EMDIO/RPK13/RK13
21	SPI1CS/RPA1	SPI1 slave select/chip select/frame sync/ remappable peripheral/ PORTA digital I/O	SPI1CS/RPA1/RA1
22	CVDT14/ERXDV/RPK12	ADC CVD controller TX output/Ethernet RX data valid input/remappable peripheral/PORTK digital I/O	CVDT14/ERXDV/RPK12/RK12

.....continued

Pin Number	Pin on Carrier Board	Pin Description on Carrier Board	Pin on WFI32E01 Module <sup>(1)(2)</sup>
23	CVDT13/ETXD0/RPC15	ADC CVD controller TX output/Ethernet transmit nibble data output/remappable peripheral/PORTC digital I/O	CVDT13/ETXD0/RPC15/RC15
24	GND	Ground	GND
25	CVDT12/ETXD1/RPC14	ADC CVD controller TX output/Ethernet transmit nibble data output/remappable peripheral/PORTC digital I/O	CVDT12/ETXD1/RPC14/RC14
26	U1TX	UART1 transmit output	U1TX
27	GND	Ground	GND
28	U1RX	UART1 receive input	U1RX
29	CVDT10/ETH_CLK_OUT/RPC12	ADC CVD controller TX output/Ethernet clock out/remappable peripheral/PORTC digital I/O	CVDT10/ETH_CLK_OUT/RPC12/RC12
30	NC	Not connected	NC
31	GND	Ground	GND
32	GND	Ground	GND
33	GND	Ground	GND
34	NC	Not connected	NC
35	CVDT8/ERXD1/RPC10	ADC CVD controller TX output/Ethernet transmit nibble data input/remappable peripheral/PORTC digital I/O	CVDT8/ERXD1/RPC10/RC10
36	SDA1/RPA5/RA5	I2C1 data/remappable peripheral/PORTA digital I/O	SDA1/RPA5/RA5
37	CVDT9/ERXD0/RPC11	ADC CVD controller TX output/Ethernet transmit nibble data input/remappable peripheral/PORTC digital I/O	CVDT9/ERXD0/RPC11/RC11
38	SCL1/RPA4	I2C1 clock/remappable peripheral/PORTA digital I/O	SCL1/RPA4/RA4
39	CVDT11/ETXEN/RPC13	ADC CVD controller TX output/Ethernet transmit enable output/remappable peripheral/PORTC digital I/O	CVDT11/ETXEN/RPC13/RC13

.....continued			
Pin Number	Pin on Carrier Board	Pin Description on Carrier Board	Pin on WFI32E01 Module <sup>(1)(2)</sup>
40	GND	Ground	GND
41	USBID/AN2/CVD2/CVDR2/CVDT5/RPB2	USB OTG ID input	USBID/AN2/CVD2/CVDR2/CVDT5/RPB2/RB2
42	RF_FE_4/RPK1	RF front-end control/remappable peripheral/PORTK digital I/O	RF_FE_4/RPK1/RK1
43	USB_D+	USB data +	USB_D+
44	RF_FE_2/RPK3	RF front-end control/remappable peripheral/PORTK digital I/O	RF_FE_2/RPK3/RK3
45	USB_D-	USB data -	USB_D-
46	GND	Ground	GND
47	VBUS	VBUS power input	VBUS
48	AN14/ANN0/CVD14/CVDR14/RPA14	Analog input/analog input/ADC CVD controller output/ADC CVD controller RX output/remappable peripheral/PORTA digital I/O	AN14/ANN0/CVD14/CVDR14/RPA14/RA14
49	VBUSON/CVD1/CVDR1/CVDT6/AN1/RPB1	On signal for external VBUS source	VBUSON/CVD1/CVDR1/CVDT6/AN1/RPB1/RB1
50	ANA0/RPB12/RB12	Analog input/remappable peripheral/PORTB digital I/O	ANA0/RPB12/RB12
51	GND	Ground	GND
52	AN15/ANN1/CVD15/CVDR15/RPA13	Analog input/analog input/ADC CVD controller output/ADC CVD controller RX output/remappable peripheral/PORTA digital I/O	AN15/ANN1/CVD15/CVDR15/RPA13/RA13
53	PGC2/AN4/CVD4/CVDR4/CVDT3/RPB4	In Circuit Serial Programming (ICSP) <sup>™</sup> programming clock/analog input/ADC CVD controller output/ADC CVD controller RX output/ADC CVD controller TX output/remappable peripheral/PORTB digital I/O	PGC2/AN4/CVD4/CVDR4/CVDT3/RPB4/RB4
54	AN17/CVD17/CVDR17/INT0/RPA10	Analog input/ADC CVD controller output/ADC CVD controller RX output/External interrupt input 0/remappable peripheral/PORTA digital I/O	AN17/CVD17/CVDR17/INT0/RPA10/RA10

.....continued

Pin Number	Pin on Carrier Board	Pin Description on Carrier Board	Pin on WFI32E01 Module <sup>(1)(2)</sup>
55	PGD2/AN5/CVD5/CVDR5/CVDT2/ RTCC/RPB5	ICSP programming data/ analog input/ADC CVD controller output/ADC CVD controller RX output/ADC CVD controller TX output/ RTCC output clock/ remappable peripheral/ PORTB digital I/O	PGD2/AN5/CVD5/CVDR5/ CVDT2/RTCC/RPB5/RB5
56	GND	Ground	GND
57	TDO/AN7/CVD7/CVDR7/RPB7	JTAG test data output/ analog input/ADC CVD controller output/ADC CVD controller RX output/ remappable peripheral/ PORTB digital I/O	TDO/AN7/CVD7/CVDR7/ RPB7/RB7
58	NC	Not connected	NC
59	TDI/PGD4/AN9/CVD9/CVDR9/ RPB9	JTAG test data/ programming data input/ ICSP programming data/ analog input/ADC CVD controller output/ADC CVD controller RX output/ remappable peripheral/ PORTB digital I/O	TDI/PGD4/AN9/CVD9/CVDR9/ RPB9/RB9
60	NC	Not connected	NC
61	TCK/PGC4/AN8/CVD8/CVDR8/ RPB8	JTAG test clock/ programming clock input/ ICSP programming clock/ analog input/ADC CVD controller output/ADC CVD controller RX output/ remappable peripheral/ PORTB digital I/O	TCK/PGC4/AN8/CVD8/CVDR8/ RPB8/RB8
62	NC	Not connected	NC
63	TMS/AN6/CVD6/CVDR6/RPB6	JTAG Test mode select input/analog input/ADC CVD controller output/ADC CVD controller RX output/ remappable peripheral/ PORTB digital I/O	TMS/AN6/CVD6/CVDR6/ RPB6/RB6
64	NC	Not connected	NC
65	SCK2/RPA11	SPI2 clock/remappable peripheral/PORTA digital I/O	SCK2/RPA11/RA11
66	NC	Not connected	NC
67	GND	Ground	GND
68	NC	Not connected	NC

.....continued

Pin Number	Pin on Carrier Board	Pin Description on Carrier Board	Pin on WFI32E01 Module <sup>(1)(2)</sup>
69	NC	Not connected	NC
70	NC	Not connected	NC
71	NC	Not connected	NC
72	3V3_IN	3.3V input power supply	3V3_IN
73	VBAT_IN	Power supply	VBAT_IN
74	3V3_IN	3.3V input power supply	3V3_IN
75	VBAT_IN	Power supply	VBAT_IN

**Notes:**

1. These are Peripheral Pin Select (PPS) pins and can be configured for any of the supported peripheral functions based on the end user application.
2. For more details on the WFI32E01 pins, refer to the *PIC32MZ1025W104 MCU and WFI32E01 Module with Wi-Fi® and Hardware-based Security Accelerator Data Sheet (DS70005425)*.

### 4. PIC32 WFI32E Curiosity Board Out of Box Demo

The Out of Box (OOB) demo connects to the cloud and allows the user to control the Curiosity board via a web-based interface. Go to [github.com/MicrochipTech/PIC32MZW1\\_Curiosity\\_OOB](https://github.com/MicrochipTech/PIC32MZW1_Curiosity_OOB) for the code and documentation related to OOB demo.

## 5. Appendix A: WFI32E01 Carrier Board

The WFI32E01 carrier board is a plug-in board designed around the WFI32E01 module. The carrier board brings all the signals from the module onto the Curiosity board for rapid prototyping. The WFI32E01 carrier board has an on-board crystal (32.768 kHz) for RTCC and a header (J102) for the current measurement (see the following figure).

**Figure 5-1. WFI32E01 Carrier Board**

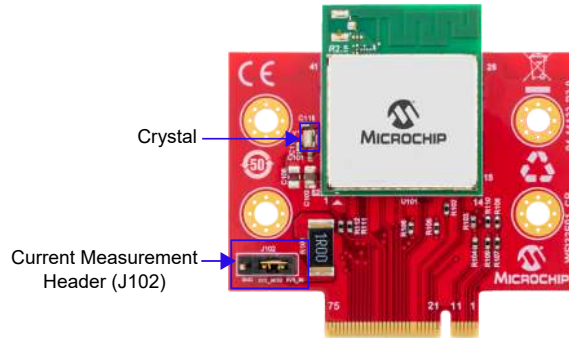

The current measurement header (J102) measures the total current consumed by the WFI32E01 module using a multimeter. To measure the total current consumption of the module, remove the jumper from J102 and connect a voltmeter across its pins. A 1Ω resistor available on-board across the jumper gives a 1:1 relationship between the voltage drop and current consumption.

The following table lists the details of the carrier board.

**Table 5-1. WFI32E01 Carrier Board Details**

Item No.	Description	Part Number	Supported Module
1	WFI32E01 carrier board	WFI32E01_CB	WFI32E01PC

# 6. Appendix B: Reference Circuit

## 6.1

### PIC32 WF132E Curiosity Board Reference Schematics

Figure 6-1. PIC32 WF132E Curiosity Board Schematics (Sheet 1 of 4)

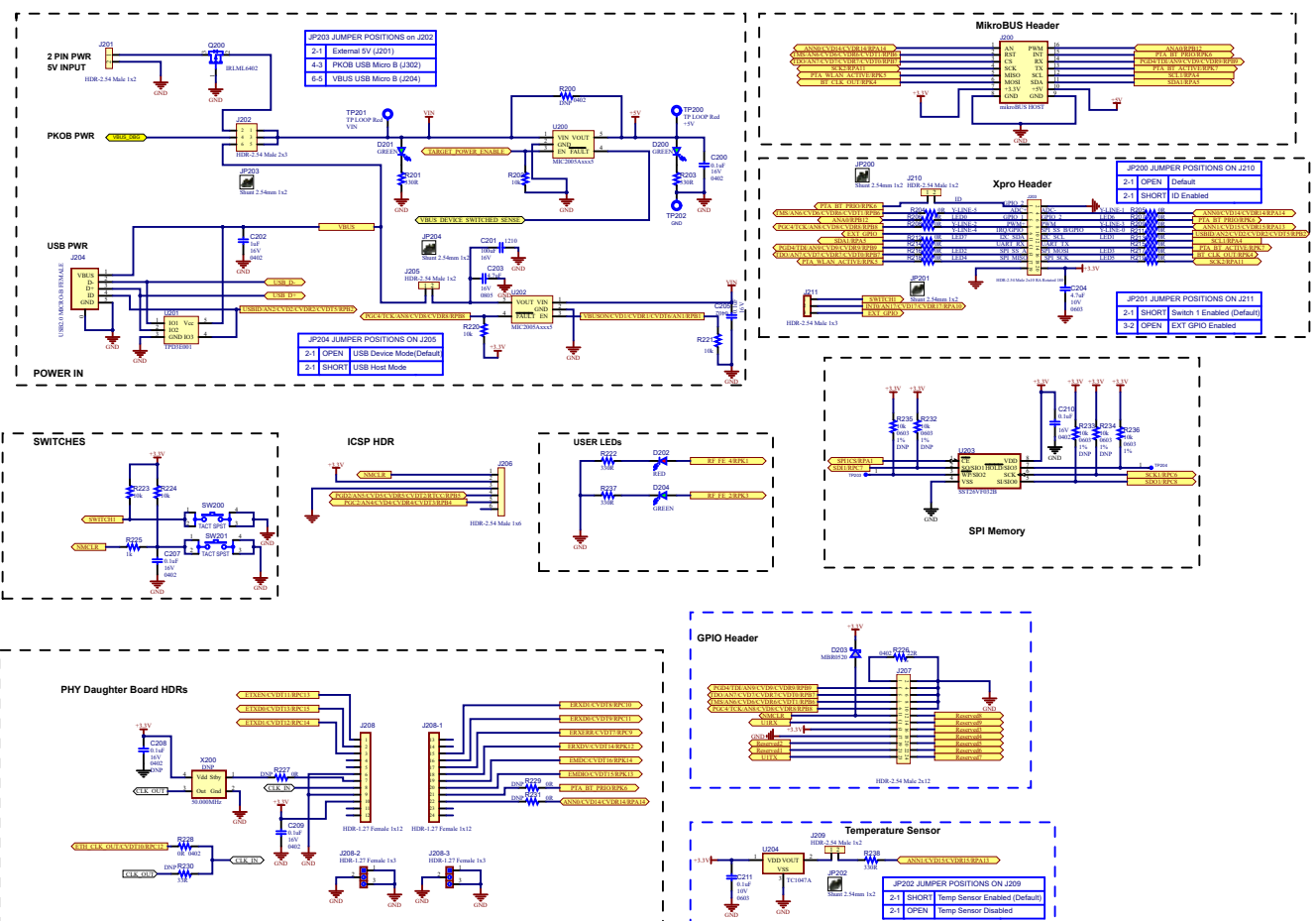



Figure 6-2. PIC32 WF132E Curiosity Board Schematics (Sheet 2 of 4)

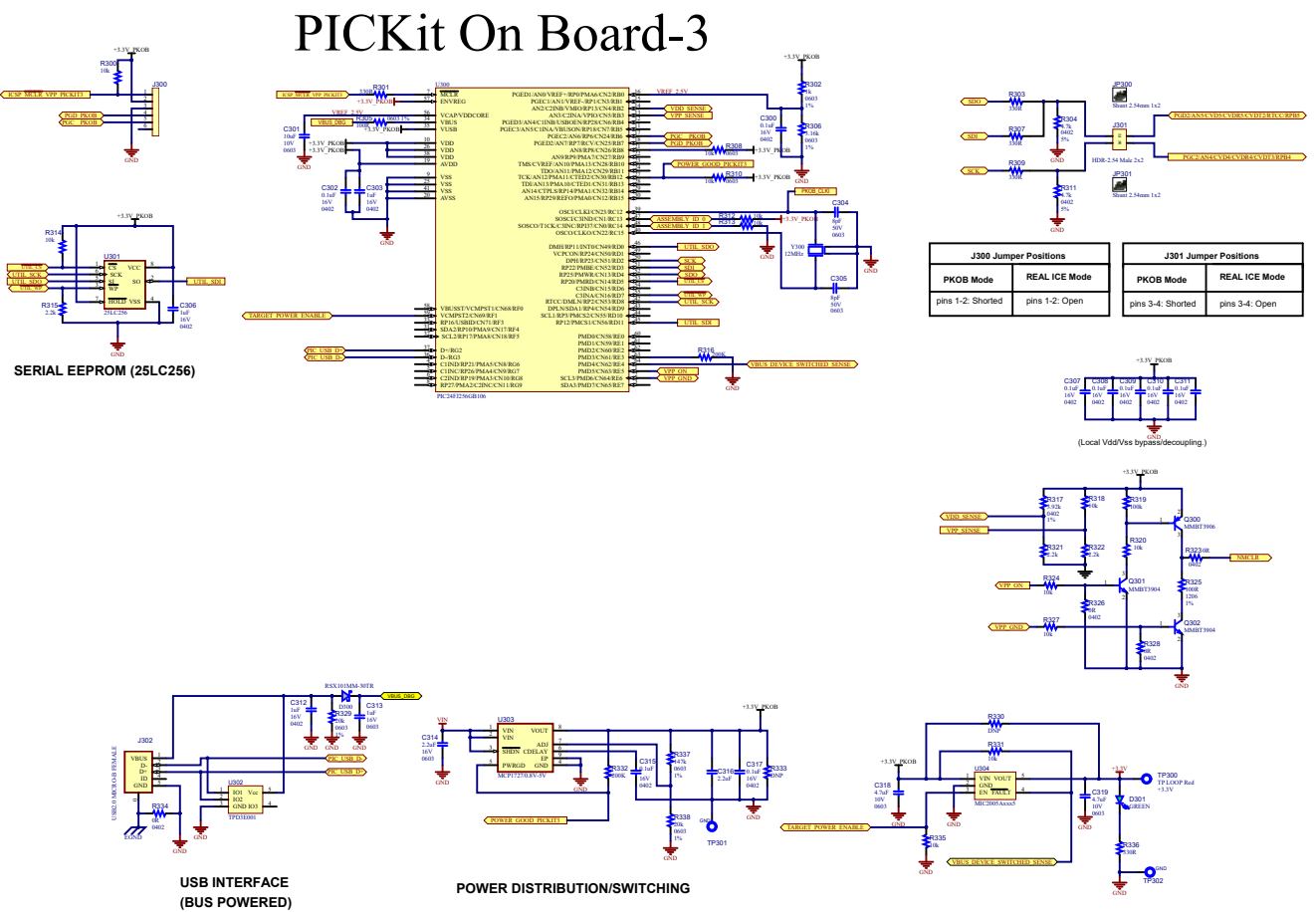

Figure 6-3. PIC32 WFI32E Curiosity Board Schematics (Sheet 3 of 4)

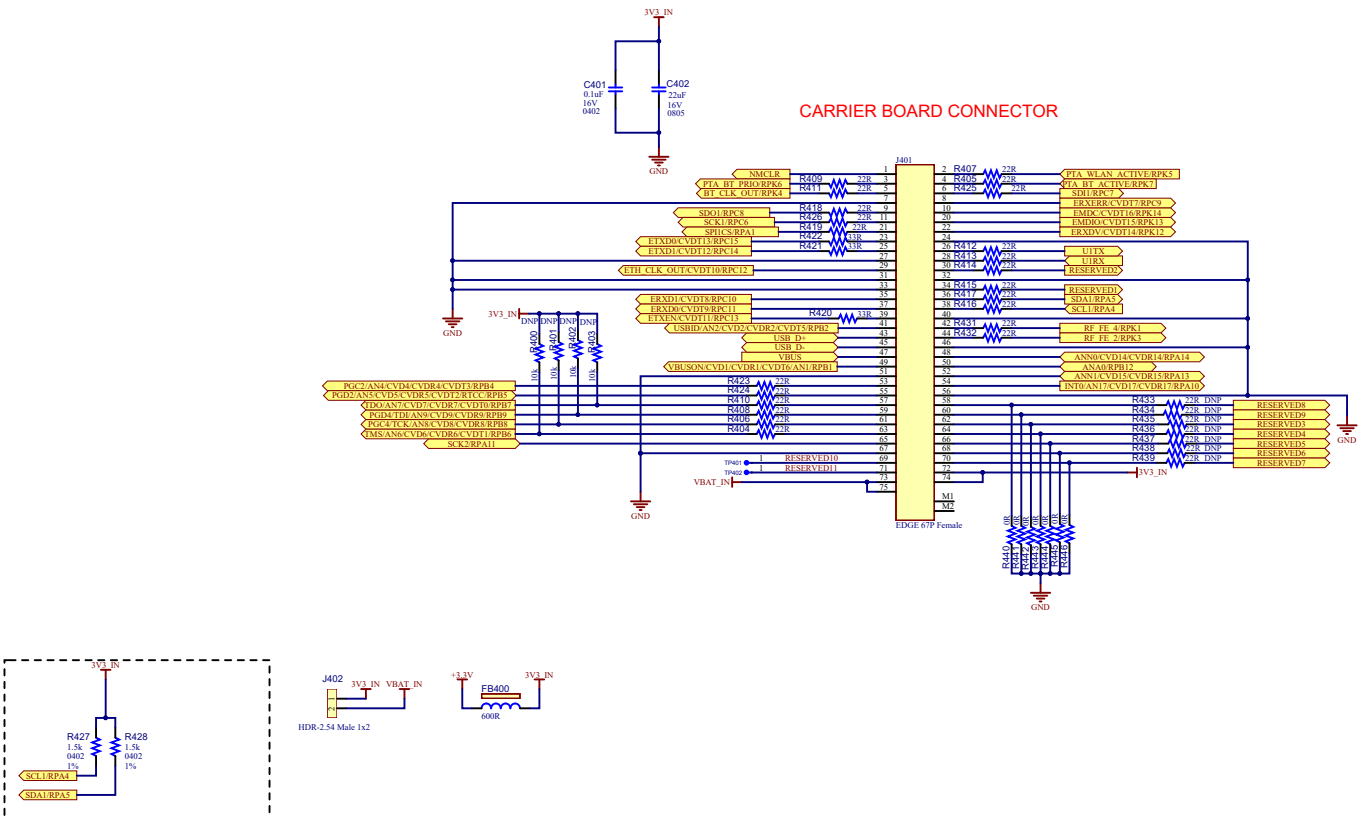
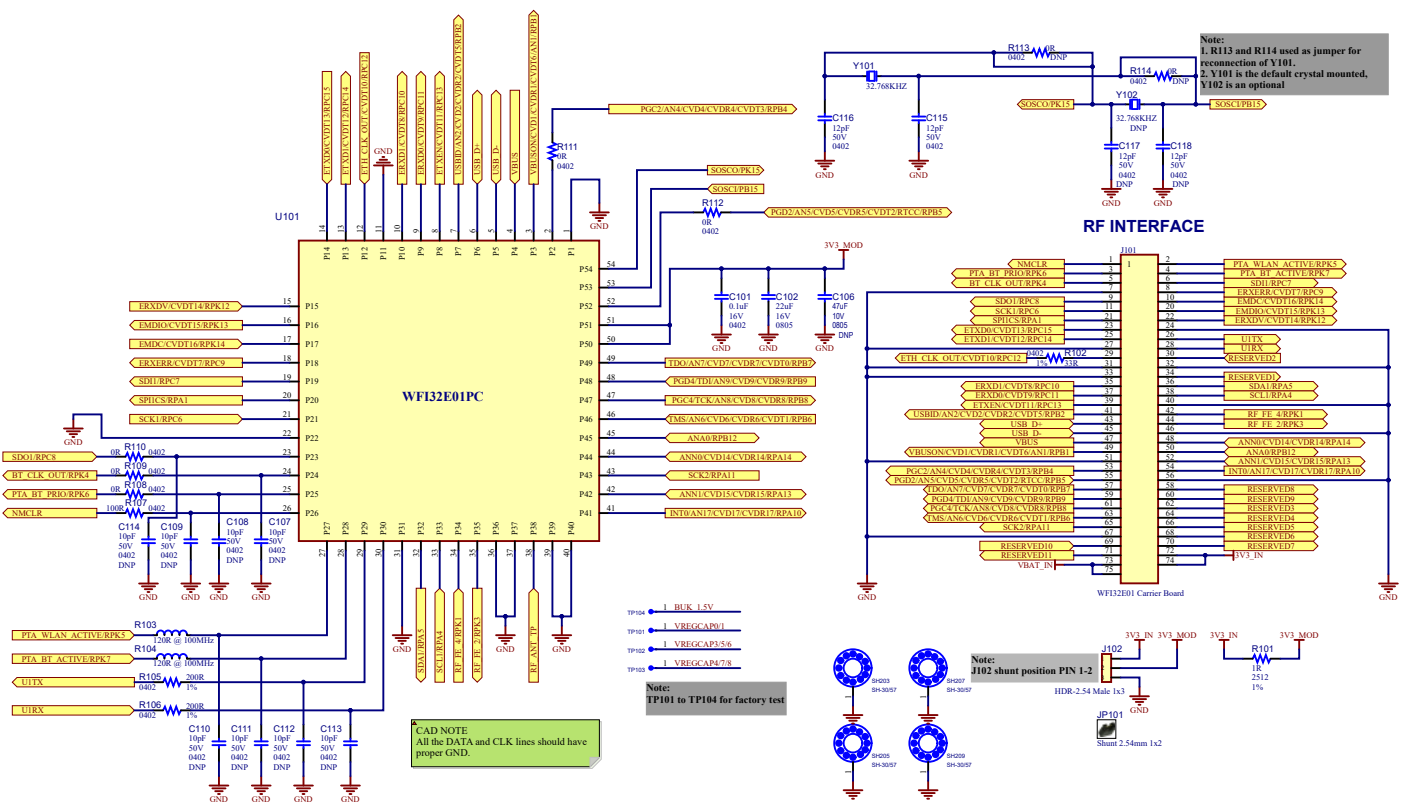

Figure 6-4. WFI32E01 Carrier Board Schematics (Sheet 4 of 4)



## 6.2 PIC32 WFI32E Curiosity Board Bill of Materials

The following table provides the Bill of Materials (BOM) for PIC32 WFI32E Curiosity Board.

**Table 6-1. Bill of Materials**

Reference	Description	Manufacturer	Part Number
C200, C205, C207, C209, C210, C300, C302, C307, C308, C309, C310, C311, C315, C317, C401	CAP CER 0.1uF 16V 10% X7R SMD 0402	Würth Electronics Inc	885012205037
C201	CAP CER 100uF 16V 20% X5R SMD 1210	Yageo	CC1210MKX5R7BB107
C202, C303, C306, C312	CAP CER 1uF 16V 10% X5R SMD 0402	Murata	GRM155R61C105KE01D
C203	CAP CER 4.7uF 16V 20% Y5V SMD 0805	Panasonic	ECJ-2FF1C475Z
C204, C318, C319	CAP CER 4.7uF 10V 10% X5R SMD 0603	KEMET	C0603C475K8PACTU
C211	CAP CER 0.1uF 10V 10% X7R SMD 0603	KEMET	C0603C104K8RACTU
C301	CAP CER 10uF 10V 20% X5R SMD 0603	Samsung	CL10A106MP8NNNC
C304, C305	CAP CER 8pF 50V 0.5pF C0G SMD 0603	Murata	GRM1885C1H8R0DZ01D
C313	CAP CER 1uF 16V 10% X5R SMD 0603	AVX	0603YD105KAT2A
C314, C316	CAP CER 2.2uF 16V 10% X5R SMD 0603	TDK	C1608X5R1C225K
C402	CAP CER 22uF 16V 10% X5R SMD 0805	TDK	C2012X5R1C226K
D200, D201, D204, D301	DIO LED GREEN 2V 30mA 35mcd Clear SMD 0603	Lite-On Inc	LTST-C191KGKT
D202	DIO LED RED 2V 30mA 2mcd Clear SMD 0603	Lite-On	LTST-C190EKT
D203	DIO SCKY MBR0520 385mV 500mA 20V SOD-123	Fairchild	MBR0520L
D300	DIODE SCHOTTKY 30V 1A PMDU	Rohm Semiconductor	RSX101MM-30TR
FB400	FERRITE 600R@100MHz 300mA SMD 0603	Laird Technologies	HZ0603C601R-00
J200	SOCKET mikroBUS HOST DIP 16 TH	Sullins Connector Solutions	PPTC081LFBN-RC
J201, J205, J209, J210, J402	CON HDR-2.54 Male 1x2 Gold 5.84MH TH VERT	FCI	77311-118-02LF

.....continued			
Reference	Description	Manufacturer	Part Number
J202	CON HDR-2.54 Male 2x3 Gold 5.84MH TH VERT	Samtec	TSW-103-07-S-D
J203	CON HDR-2.54 Male 2x10 Rotated 180Degrees Gold TH RT ANGLE	Sullins Connector Solutions	PBC10DBAN
J204, J302	CON USB2.0 MICRO-B FEMALE TH/SMD R/A	FCI	10118194-0001LF
J206	CON HDR-2.54 Male 1x6 Gold 5.84MH TH R/A	FCI	68016-106HLF
J207	CON HDR-2.54 Male 2x12 Gold 5.84MH TH R/A	FCI	68021-224HLF
J208-2, J208-3	CON STRIP-1.27 Female 1x3 Gold TH VERT	Samtec	SLM-103-01-L-S
J208, J208-1	CON STRIP-1.27 Female 1x12 Gold TH VERT	Samtec	SLM-112-01-L-S
J211	CON HDR-2.54 Male 1x3 Gold 5.84MH TH VERT	FCI	68000-103HLF
J301	CON HDR-2.54 Male 2x2 Gold 5.84MH TH VERT	Samtec	TSW-102-07-G-D
J401	CON EDGE MINI 0.5mm 67P Female SMD R/A	TE Connectivity AMP Connectors	2199230-3
Q200	TRANS FET P-CH IRLML6402 -20V -3.7A 1.3W SOT-23-3	International Rectifier	IRLML6402TRPBF
Q300	TRANS BJT PNP MMBT3906 -40V -200mA 300mW SOT-23-3	NXP Semiconductors	PMBT3906,215
Q301, Q302	TRANS BJT NPN MMBT3904 40V 200mA 310mW SOT-23-3	Diodes Incorporated	MMBT3904-7
R201, R203, R222, R237, R238, R301, R303, R307, R309, R336	RES TKF 330R 5% 1/10W SMD 0402	Panasonic Electronic Components	ERJ-2GEJ331X
R202, R220, R221, R223, R224, R300, R314, R318, R320, R324, R327, R331, R335	RES TKF 10k 1% 1/10W SMD 0402	Panasonic	ERJ-2RKF1002X
R204, R205, R206, R207, R208, R209, R211, R212, R213, R214, R215, R216, R217, R218, R219, R228	RES TKF 0R SMD 0402, RES TKF 0R SMD 0402 AEC-Q200	Panasonic	ERJ-2GE0R00X
R225	RES TKF 1k 1% 1/10W SMD 0402	Panasonic	ERJ-2RKF1001X

# PIC32 WFI32E

## Appendix B: Reference Circuit

.....continued			
Reference	Description	Manufacturer	Part Number
R226, R404, R405, R406, R407, R408, R409, R410, R411, R412, R413, R414, R415, R416, R417, R418, R419, R423, R424, R425, R426, R431, R432	RES TKF 22R 1% 1/20W SMD 0402	Panasonic Electronic Components	ERJ-2RKF22R0X
R236, R308, R310, R312, R313	RES TF 10k 1% 1/8W SMD 0603	Vishay Beyschlag	MCT06030C1002FP500
R302	RES TKF 1k 1% 1/10W SMD 0603	Panasonic	ERJ-3EKF1001V
R304, R311	RES TKF 4.7k 5% 1/10W SMD 0402	Panasonic	ERJ-2GEJ472X
R305	RES TKF 100R 1% 1/10W SMD 0603	Panasonic	ERJ-3EKF1000V
R306	RES TKF 3.16k 1% 1/10W SMD 0603	Panasonic	ERJ-3EKF3161V
R315, R321, R322	RES TKF 2.2k 1% 1/10W SMD 0402	Panasonic	ERJ-2RKF2201X
R316, R332	RES TKF 200k 1% 1/10W SMD 0402	Panasonic	ERJ-2RKF2003X
R317	RES TKF 3.92K 1% 1/16W SMD 0402	Yageo	RC0402FR-073K92L
R319	RES TKF 100k 1% 1/10W SMD 0402	Panasonic	ERJ-2RKF1003X
R323, R326, R328, R334, R440, R441, R442, R443, R444, R445, R446	RES TKF 0R 1/16W SMD 0402	Yageo	RC0402JR-070RL
R325	RES TKF 100R 1% 1/4W SMD 1206	Yageo	RC1206FR-07100RL
R329, R338	RES TKF 20k 1% 1/10W SMD 0603	Panasonic	ERJ-3EKF2002V
R337	RES TKF 147k 1% 1/10W SMD 0603	Panasonic	ERJ-3EKF1473V
R420, R421, R422	RES TKF 33R 1% 1/10W SMD 0402	Panasonic Electronic Components	ERJ-2RKF33R0X
R427, R428	RES TKF 1.5K 1% 1/16W SMD 0402	Yageo	RC0402FR-071K5L
SW200, SW201	SWITCH TACT SPST 12V 50mA TL3301AF160QG SMD	E-Switch	TL3301AF160QG
TP200, TP201, TP300	MISC, TEST POINT MULTI PURPOSE MINI RED	Keystone	5000

.....continued

Reference	Description	Manufacturer	Part Number
TP202, TP301, TP302	MISC, TEST POINT MULTI PURPOSE MINI BLACK	Keystone	5001
U201, U302	DIO TVS ARRAY TPD3E001DRLR 11V 90W SMD SOT-553	Texas Instruments	TPD3E001DRLR
U200, U202, U304	MCHP ANALOG POWER SWITCH 5.5V 500mA MIC2005A-1YM5-TR SOT-23-5	Microchip Technology	MIC2005A-1YM5-TR
U203	MCHP MEMORY SERIAL FLASH SST26VF032B-104I/SM SOIJ-8	Microchip Technology	SST26VF032B-104I/SM
U204	MCHP ANALOG TEMPERATURE SENSOR -40C to +125C TC1047AVNBTR SOT-23-3	Microchip Technology	TC1047AVNBTR
U300	MCHP MCU 16-BIT 32MHz 256kB 16kB PIC24FJ256GB106-I/PT TQFP-64	Microchip Technology	PIC24FJ256GB106T-I/PT
U301	MCHP MEMORY SERIAL EEPROM 256k SPI 25LC256-E/SN SOIC-8	Microchip Technology	25LC256T-E/SN
U303	MCHP ANALOG LDO 0.8V-5V MCP1727T-ADJE/MF DFN-8	Microchip Technology	MCP1727T-ADJE/MF
Y300	CRYSTAL 12MHz 8pF SMD NX3225SA	NDK	NX3225SA-12MHZ-STD-CSR-6

### 6.3 WFI32E01 Carrier Board Bill of Materials

The following table provides the Bill of Materials (BOM) for the WFI32E01 carrier board.

**Table 6-2. Bill of Materials**

Reference	Description	Manufacturer	Part Number
C101	CAP CER 0.1 uF 16V 10% X7R SMD 0402	Murata	GRM155R71C104KA88D
C102	CAP CER 22 uF 16V 10% X5R SMD 0805	TDK	C2012X5R1C226K125AC
C115, C116	CAP CER 12 pF 50V 1% NP0 SMD 0402	Murata Electronics North America	GRM1555C1H120FA01D
J102	CON HDR-2.54 Male 1x3 Gold 5.84 MH TH VERT	FCI	68000-103HLF
R101	RES TKF 1R 1% 1W SMD 2512	Vishay Dale	CRCW25121R00FKEG
R102	RES TKF 33R 1% 1/16W SMD 0402	Rohm Semiconductor	MCR01MRTF33R0
R103, R104	FERRITE 120R at 100 MHz 0.55A 0.19R SMD 0402	Murata Electronics	BLM15AG121SN1D

# PIC32 WFI32E

## Appendix B: Reference Circuit

.....continued			
Reference	Description	Manufacturer	Part Number
R105, R106	RES TKF 200R 1% 1/10W SMD 0402	Panasonic	ERJ-2RKF2000X
R107	RES TKF 100R 5% 1/16W SMD 0402	Yageo	RC0402JR-07100RL
R108, R109, R110, R111, R112	RES TKF 0R 1/16W SMD 0402	Yageo	RC0402JR-070RL
U101	MOD, WFI32E01 Wi-Fi with PCB Antenna and Trust&GO, 54Pin SMD	Microchip Technology	WFI32E01PC-I
Y101	CRYSTAL 32.768 kHz 12.5 PF SMD 2-SMD, No Lead	Epson	FC-12M 32.7680KA-A5



## 7. Regulatory Approval

This equipment (PIC32 WFI32E Curiosity Board/EV12F11A) is an evaluation kit and not a finished product. It is intended for laboratory evaluation purposes only. It is not directly marketed or sold to the general public through retail; it is only sold through authorized distributors or through Microchip. Using this requires a significant engineering expertise towards understanding of the tools and relevant technology, which can be expected only from a person who is professionally trained in the technology.

Regulatory compliance settings have to follow the WFI32E01 module certifications. The following regulatory notices are to cover the requirements under the regulatory approval.

### 7.1 United States

The PIC32 WFI32E Curiosity Board (EV12F11A) contains the WFI32E01 module, which has received Federal Communications Commission (FCC) CFR47 Telecommunications, Part 15 Subpart C “Intentional Radiators” single-modular approval in accordance with Part 15.212 Modular Transmitter approval.

Contains FCC ID: 2ADHKWFI32E01

**This device complies with Part 15 of the FCC Rules. Operation is subject to the following two conditions: (1) this device may not cause harmful interference, and (2) this device must accept any interference received, including interference that may cause undesired operation.**



**Important:** FCC Radiation Exposure Statement

This equipment complies with FCC radiation exposure limits set forth for uncontrolled environment. The antenna(s) used for this transmitter must be installed to provide a separation distance of at least 8 cm from all persons and must not be co-located or operating in conjunction with any other antenna or transmitter. This transmitter is restricted for use with the specific antenna(s) tested in this application for certification.



Any changes or modifications not expressly approved by the party responsible for compliance could void the user's authority to operate this equipment.

**Note:** This equipment has been tested and found to comply with the limits for a Class B digital device, pursuant to part 15 of the FCC rules. These limits are designed to provide reasonable protection against harmful interference in a residential installation. This equipment generates, uses and can radiate radio frequency energy and, if not installed and used in accordance with the instructions, may cause harmful interference to radio communications. However, there is no guarantee that interference will not occur in a particular installation. If this equipment does cause harmful interference to radio or television reception, which can be determined by turning the equipment off and on, the user is encouraged to try to correct the interference by one or more of the following measures:

- Reorient or relocate the receiving antenna.
- Increase the separation between the equipment and receiver.
- Connect the equipment into an outlet on a circuit different from that to which the receiver is connected.
- Consult the dealer or an experienced radio/TV technician for help.

### 7.2 Canada

The PIC32 WFI32E Curiosity Board (EV12F11A) contains the WFI32E01 module, which has been certified for use in Canada under Innovation, Science and Economic Development Canada (ISED, formerly Industry Canada) Radio Standards Procedure (RSP) RSP-100, Radio Standards Specification (RSS) RSS-Gen and RSS-247.

Contains IC: 20266-WFI32E01

This device contains license-exempt transmitter(s)/receiver(s) that comply with Innovation, Science and Economic Development Canada's license-exempt RSS(s). Operation is subject to the following two conditions:

1. This device may not cause interference;
2. This device must accept any interference, including interference that may cause undesired operation of the device.

L'émetteur/récepteur exempt de licence contenu dans le présent appareil est conforme aux CNR d'Innovation, Sciences et Développement économique Canada applicables aux appareils radio exempts de licence. L'exploitation est autorisée aux deux conditions suivantes:

1. L'appareil ne doit pas produire de brouillage;
2. L'appareil doit accepter tout brouillage radioélectrique subi, même si le brouillage est susceptible d'en compromettre le fonctionnement.



This equipment complies with radio frequency exposure limits set forth by Innovation, Science and Economic Development Canada for an uncontrolled environment. This equipment should be installed and operated with a minimum distance of 20 cm between the device and the user or bystanders.

Cet équipement est conforme aux limites d'exposition aux radiofréquences définies par d'Innovation, Sciences et Développement économique Canada pour un environnement non contrôlé. Cet équipement doit être installé et utilisé avec un minimum de 20 cm de distance entre le dispositif et l'utilisateur ou des tiers.

## 7.3 Europe

This equipment (EV12F11A) has been assessed under the Radio Equipment Directive (RED) for use in European Union countries. The product does not exceed the specified power ratings, antenna specifications and/or installation requirements as specified in the user manual. A Declaration of Conformity is issued for each of these standards and kept on file as described in Radio Equipment Directive (RED).

### **Simplified EU Declaration of Conformity**

Hereby, Microchip Technology Inc. declares that the radio equipment type [EV12F11A] is in compliance with Directive 2014/53/EU.

The full text of the EU declaration of conformity is available at [www.microchip.com/developmenttools/ProductDetails/PartNO/EV12F11A](http://www.microchip.com/developmenttools/ProductDetails/PartNO/EV12F11A).

**8. Document Revision History**

Revision	Date	Section	Description
A	09/2020	Document	Initial revision

---

## The Microchip Website

---

Microchip provides online support via our website at [www.microchip.com/](http://www.microchip.com/). This website is used to make files and information easily available to customers. Some of the content available includes:

- **Product Support** – Data sheets and errata, application notes and sample programs, design resources, user's guides and hardware support documents, latest software releases and archived software
- **General Technical Support** – Frequently Asked Questions (FAQs), technical support requests, online discussion groups, Microchip design partner program member listing
- **Business of Microchip** – Product selector and ordering guides, latest Microchip press releases, listing of seminars and events, listings of Microchip sales offices, distributors and factory representatives

---

## Product Change Notification Service

---

Microchip's product change notification service helps keep customers current on Microchip products. Subscribers will receive email notification whenever there are changes, updates, revisions or errata related to a specified product family or development tool of interest.

To register, go to [www.microchip.com/pcn](http://www.microchip.com/pcn) and follow the registration instructions.

---

## Customer Support

---

Users of Microchip products can receive assistance through several channels:

- Distributor or Representative
- Local Sales Office
- Embedded Solutions Engineer (ESE)
- Technical Support

Customers should contact their distributor, representative or ESE for support. Local sales offices are also available to help customers. A listing of sales offices and locations is included in this document.

Technical support is available through the website at: [www.microchip.com/support](http://www.microchip.com/support)

---

## Microchip Devices Code Protection Feature

---

Note the following details of the code protection feature on Microchip devices:

- Microchip products meet the specifications contained in their particular Microchip Data Sheet.
- Microchip believes that its family of products is secure when used in the intended manner and under normal conditions.
- There are dishonest and possibly illegal methods being used in attempts to breach the code protection features of the Microchip devices. We believe that these methods require using the Microchip products in a manner outside the operating specifications contained in Microchip's Data Sheets. Attempts to breach these code protection features, most likely, cannot be accomplished without violating Microchip's intellectual property rights.
- Microchip is willing to work with any customer who is concerned about the integrity of its code.
- Neither Microchip nor any other semiconductor manufacturer can guarantee the security of its code. Code protection does not mean that we are guaranteeing the product is "unbreakable." Code protection is constantly evolving. We at Microchip are committed to continuously improving the code protection features of our products. Attempts to break Microchip's code protection feature may be a violation of the Digital Millennium Copyright Act. If such acts allow unauthorized access to your software or other copyrighted work, you may have a right to sue for relief under that Act.

---

## Legal Notice

---

Information contained in this publication is provided for the sole purpose of designing with and using Microchip products. Information regarding device applications and the like is provided only for your convenience and may be superseded by updates. It is your responsibility to ensure that your application meets with your specifications.

THIS INFORMATION IS PROVIDED BY MICROCHIP "AS IS". MICROCHIP MAKES NO REPRESENTATIONS OR WARRANTIES OF ANY KIND WHETHER EXPRESS OR IMPLIED, WRITTEN OR ORAL, STATUTORY OR OTHERWISE, RELATED TO THE INFORMATION INCLUDING BUT NOT LIMITED TO ANY IMPLIED WARRANTIES OF NON-INFRINGEMENT, MERCHANTABILITY, AND FITNESS FOR A PARTICULAR PURPOSE OR WARRANTIES RELATED TO ITS CONDITION, QUALITY, OR PERFORMANCE.

IN NO EVENT WILL MICROCHIP BE LIABLE FOR ANY INDIRECT, SPECIAL, PUNITIVE, INCIDENTAL OR CONSEQUENTIAL LOSS, DAMAGE, COST OR EXPENSE OF ANY KIND WHATSOEVER RELATED TO THE INFORMATION OR ITS USE, HOWEVER CAUSED, EVEN IF MICROCHIP HAS BEEN ADVISED OF THE POSSIBILITY OR THE DAMAGES ARE FORESEEABLE. TO THE FULLEST EXTENT ALLOWED BY LAW, MICROCHIP'S TOTAL LIABILITY ON ALL CLAIMS IN ANY WAY RELATED TO THE INFORMATION OR ITS USE WILL NOT EXCEED THE AMOUNT OF FEES, IF ANY, THAT YOU HAVE PAID DIRECTLY TO MICROCHIP FOR THE INFORMATION. Use of Microchip devices in life support and/or safety applications is entirely at the buyer's risk, and the buyer agrees to defend, indemnify and hold harmless Microchip from any and all damages, claims, suits, or expenses resulting from such use. No licenses are conveyed, implicitly or otherwise, under any Microchip intellectual property rights unless otherwise stated.

---

## Trademarks

---

The Microchip name and logo, the Microchip logo, Adaptec, AnyRate, AVR, AVR logo, AVR Freaks, BesTime, BitCloud, chipKIT, chipKIT logo, CryptoMemory, CryptoRF, dsPIC, FlashFlex, flexPWR, HELDO, IGLOO, JukeBlox, KeeLoq, Klear, LANCheck, LinkMD, maXStylus, maXTouch, MediaLB, megaAVR, Microsemi, Microsemi logo, MOST, MOST logo, MPLAB, OptoLyzer, PackeTime, PIC, picoPower, PICSTART, PIC32 logo, PolarFire, Prochip Designer, QTouch, SAM-BA, SenGenuity, SpyNIC, SST, SST Logo, SuperFlash, Symmetricom, SyncServer, Tachyon, TempTrackr, TimeSource, tinyAVR, UNI/O, Vectron, and XMEGA are registered trademarks of Microchip Technology Incorporated in the U.S.A. and other countries.

APT, ClockWorks, The Embedded Control Solutions Company, EtherSynch, FlashTec, Hyper Speed Control, HyperLight Load, IntelliMOS, Libero, motorBench, mTouch, Powermite 3, Precision Edge, ProASIC, ProASIC Plus, ProASIC Plus logo, Quiet-Wire, SmartFusion, SyncWorld, Temux, TimeCesium, TimeHub, TimePictra, TimeProvider, Vite, WinPath, and ZL are registered trademarks of Microchip Technology Incorporated in the U.S.A.

Adjacent Key Suppression, AKS, Analog-for-the-Digital Age, Any Capacitor, AnyIn, AnyOut, BlueSky, BodyCom, CodeGuard, CryptoAuthentication, CryptoAutomotive, CryptoCompanion, CryptoController, dsPICDEM, dsPICDEM.net, Dynamic Average Matching, DAM, ECAN, EtherGREEN, In-Circuit Serial Programming, ICSP, INICnet, Inter-Chip Connectivity, JitterBlocker, KlearNet, KlearNet logo, memBrain, Mindi, MiWi, MPASM, MPF, MPLAB Certified logo, MPLIB, MPLINK, MultiTRAK, NetDetach, Omniscient Code Generation, PICDEM, PICDEM.net, PICkit, PICtail, PowerSmart, PureSilicon, QMatrix, REAL ICE, Ripple Blocker, SAM-ICE, Serial Quad I/O, SMART-I.S., SQI, SuperSwitcher, SuperSwitcher II, Total Endurance, TSHARC, USBCheck, VariSense, ViewSpan, WiperLock, Wireless DNA, and ZENA are trademarks of Microchip Technology Incorporated in the U.S.A. and other countries.

SQTP is a service mark of Microchip Technology Incorporated in the U.S.A.

The Adaptec logo, Frequency on Demand, Silicon Storage Technology, and Symmcom are registered trademarks of Microchip Technology Inc. in other countries.

GestIC is a registered trademark of Microchip Technology Germany II GmbH & Co. KG, a subsidiary of Microchip Technology Inc., in other countries.

All other trademarks mentioned herein are property of their respective companies.

© 2020, Microchip Technology Incorporated, Printed in the U.S.A., All Rights Reserved.

ISBN: 978-1-5224-6576-8

## Quality Management System

---

For information regarding Microchip's Quality Management Systems, please visit [www.microchip.com/quality](http://www.microchip.com/quality).

## Worldwide Sales and Service

AMERICAS	ASIA/PACIFIC	ASIA/PACIFIC	EUROPE
<p><b>Corporate Office</b> 2355 West Chandler Blvd. Chandler, AZ 85224-6199 Tel: 480-792-7200 Tel: 480-792-7277 Technical Support: <a href="http://www.microchip.com/support">www.microchip.com/support</a> Web Address: <a href="http://www.microchip.com">www.microchip.com</a></p> <p><b>Atlanta</b> Duluth, GA Tel: 678-957-9614 Fax: 678-957-1455</p> <p><b>Austin, TX</b> Tel: 512-257-3370</p> <p><b>Boston</b> Westborough, MA Tel: 774-760-0087 Fax: 774-760-0088</p> <p><b>Chicago</b> Itasca, IL Tel: 630-285-0071 Fax: 630-285-0075</p> <p><b>Dallas</b> Addison, TX Tel: 972-818-7423 Fax: 972-818-2924</p> <p><b>Detroit</b> Novi, MI Tel: 248-848-4000</p> <p><b>Houston, TX</b> Tel: 281-894-5983</p> <p><b>Indianapolis</b> Noblesville, IN Tel: 317-773-8323 Fax: 317-773-5453 Tel: 317-536-2380</p> <p><b>Los Angeles</b> Mission Viejo, CA Tel: 949-462-9523 Fax: 949-462-9608 Tel: 951-273-7800</p> <p><b>Raleigh, NC</b> Tel: 919-844-7510</p> <p><b>New York, NY</b> Tel: 631-435-6000</p> <p><b>San Jose, CA</b> Tel: 408-735-9110 Tel: 408-436-4270</p> <p><b>Canada - Toronto</b> Tel: 905-695-1980 Fax: 905-695-2078</p>	<p><b>Australia - Sydney</b> Tel: 61-2-9868-6733</p> <p><b>China - Beijing</b> Tel: 86-10-8569-7000</p> <p><b>China - Chengdu</b> Tel: 86-28-8665-5511</p> <p><b>China - Chongqing</b> Tel: 86-23-8980-9588</p> <p><b>China - Dongguan</b> Tel: 86-769-8702-9880</p> <p><b>China - Guangzhou</b> Tel: 86-20-8755-8029</p> <p><b>China - Hangzhou</b> Tel: 86-571-8792-8115</p> <p><b>China - Hong Kong SAR</b> Tel: 852-2943-5100</p> <p><b>China - Nanjing</b> Tel: 86-25-8473-2460</p> <p><b>China - Qingdao</b> Tel: 86-532-8502-7355</p> <p><b>China - Shanghai</b> Tel: 86-21-3326-8000</p> <p><b>China - Shenyang</b> Tel: 86-24-2334-2829</p> <p><b>China - Shenzhen</b> Tel: 86-755-8864-2200</p> <p><b>China - Suzhou</b> Tel: 86-186-6233-1526</p> <p><b>China - Wuhan</b> Tel: 86-27-5980-5300</p> <p><b>China - Xian</b> Tel: 86-29-8833-7252</p> <p><b>China - Xiamen</b> Tel: 86-592-2388138</p> <p><b>China - Zhuhai</b> Tel: 86-756-3210040</p>	<p><b>India - Bangalore</b> Tel: 91-80-3090-4444</p> <p><b>India - New Delhi</b> Tel: 91-11-4160-8631</p> <p><b>India - Pune</b> Tel: 91-20-4121-0141</p> <p><b>Japan - Osaka</b> Tel: 81-6-6152-7160</p> <p><b>Japan - Tokyo</b> Tel: 81-3-6880-3770</p> <p><b>Korea - Daegu</b> Tel: 82-53-744-4301</p> <p><b>Korea - Seoul</b> Tel: 82-2-554-7200</p> <p><b>Malaysia - Kuala Lumpur</b> Tel: 60-3-7651-7906</p> <p><b>Malaysia - Penang</b> Tel: 60-4-227-8870</p> <p><b>Philippines - Manila</b> Tel: 63-2-634-9065</p> <p><b>Singapore</b> Tel: 65-6334-8870</p> <p><b>Taiwan - Hsin Chu</b> Tel: 886-3-577-8366</p> <p><b>Taiwan - Kaohsiung</b> Tel: 886-7-213-7830</p> <p><b>Taiwan - Taipei</b> Tel: 886-2-2508-8600</p> <p><b>Thailand - Bangkok</b> Tel: 66-2-694-1351</p> <p><b>Vietnam - Ho Chi Minh</b> Tel: 84-28-5448-2100</p>	<p><b>Austria - Wels</b> Tel: 43-7242-2244-39 Fax: 43-7242-2244-393</p> <p><b>Denmark - Copenhagen</b> Tel: 45-4485-5910 Fax: 45-4485-2829</p> <p><b>Finland - Espoo</b> Tel: 358-9-4520-820</p> <p><b>France - Paris</b> Tel: 33-1-69-53-63-20 Fax: 33-1-69-30-90-79</p> <p><b>Germany - Garching</b> Tel: 49-8931-9700</p> <p><b>Germany - Haan</b> Tel: 49-2129-3766400</p> <p><b>Germany - Heilbronn</b> Tel: 49-7131-72400</p> <p><b>Germany - Karlsruhe</b> Tel: 49-721-625370</p> <p><b>Germany - Munich</b> Tel: 49-89-627-144-0 Fax: 49-89-627-144-44</p> <p><b>Germany - Rosenheim</b> Tel: 49-8031-354-560</p> <p><b>Israel - Ra'anana</b> Tel: 972-9-744-7705</p> <p><b>Italy - Milan</b> Tel: 39-0331-742611 Fax: 39-0331-466781</p> <p><b>Italy - Padova</b> Tel: 39-049-7625286</p> <p><b>Netherlands - Drunen</b> Tel: 31-416-690399 Fax: 31-416-690340</p> <p><b>Norway - Trondheim</b> Tel: 47-72884388</p> <p><b>Poland - Warsaw</b> Tel: 48-22-3325737</p> <p><b>Romania - Bucharest</b> Tel: 40-21-407-87-50</p> <p><b>Spain - Madrid</b> Tel: 34-91-708-08-90 Fax: 34-91-708-08-91</p> <p><b>Sweden - Gothenberg</b> Tel: 46-31-704-60-40</p> <p><b>Sweden - Stockholm</b> Tel: 46-8-5090-4654</p> <p><b>UK - Wokingham</b> Tel: 44-118-921-5800 Fax: 44-118-921-5820</p>