

used for: FULL METAL π -FILTER

POS.	PART NO. SOCKET CONNECTOR / PLUG CONNECTOR 4-40 UNC			
	2 x 180pF±20%	2 x 370pF±20%	2 x 830pF±20%	2 x 1300pF±20%
9	MAP1XAAAH02R361X	MAP1XAAAH02R741X	MAP1XAAAH02R162X	MAP1XAAAH02R262X
15	MAP2XAAAH02R361X	MAP2XAAAH02R741X	MAP2XAAAH02R162X	MAP2XAAAH02R262X
25	MAP3XAAAH02R361X	MAP3XAAAH02R741X	MAP3XAAAH02R162X	MAP3XAAAH02R262X
37	MAP4XAAAH02R361X	MAP4XAAAH02R741X	MAP4XAAAH02R162X	MAP4XAAAH02R262X

POS.	A ^{-0.76}	B1 ^{-0.25}	B2 ^{+0.25}	C	D ^{-0.3}
9	31.19	16.46	16.79	25.00 ^{+0.12} _{-0.13}	6.12
15	39.52	24.79	25.12	33.30 ^{+0.15} _{-0.1}	6.12
25	53.42	38.50	38.84	47.04 ^{+0.13}	5.99
37	69.70	54.96	55.30	63.50 ^{+0.13}	5.99

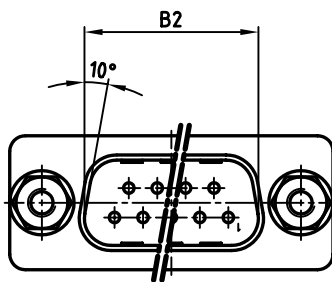
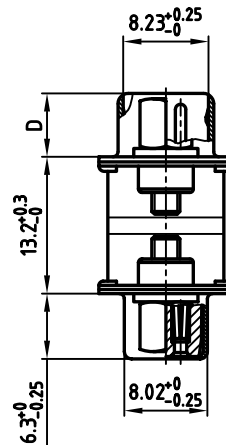
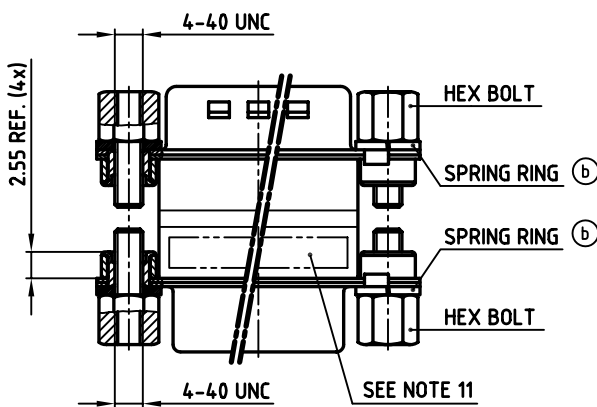
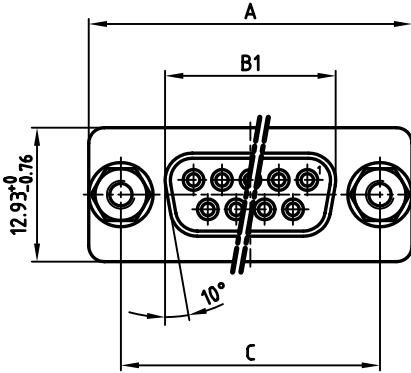

NOTES:

- METALSHELLS: STEEL; min. 315µm TIN over 40-80µm NICKEL
- INSULATORS: PBT GF UL 94 V-0, BLACK
- CONTACTS: COPPER ALLOY
PLATING: 8µm HARD GOLD over min. 50µm NICKEL
- THREADED INSERT: COPPER ALLOY; min. 200µm TIN over 80µm NICKEL
- COLLAR: COPPER ALLOY; min. 200µm TIN over 80µm NICKEL
- HEX BOLT: STEEL; NICKEL PLATED
- SPRING RING: STEEL; NICKEL PLATED
- CAPACITANCE: SEE TABLE
- DIELECTRIC WITHSTANDING VOLTAGE: 300 VDC
- MAXIMUM TORQUE VALUE FOR THREAD: 6 in.LB
- CONNECTOR IS PART MARKED: PART-NO. CONEC ABC

Directive 2002/95 EC
RoHS
Compliant

APPROVAL # FREIGABE # DEBLOCAGE # AUTORIZACION # APPROVAL	APPROVAL # FREIGABE # DEBLOCAGE # AUTORIZACION # APPROVAL
CUSTOMER APPROVAL DATE:	
NAME:	TITLE:
COMPANY NAME:	
APPROVAL # FREIGABE # DEBLOCAGE # AUTORIZACION # APPROVAL	APPROVAL # FREIGABE # DEBLOCAGE # AUTORIZACION # APPROVAL

THIS DRAWING MAY NOT BE COPIED OR REPRODUCED IN ANY WAY, AND MAY NOT BE PASSED ON TO A THIRD PARTY, WITHOUT WRITTEN PERMISSION.
 OWNERSHIP AND COPYRIGHT OF CONEC GmbH
 DO NOT ALTER CAD DRAWING BY HAND

rev.	description	date	name
2 x c	Ä 2720	06.06.2007	Lehmen
2 x b	Ä 1744	06.03.2003	Parei
a	Origin		



tolerance	scale: 2:1
material: SEE NOTES	material: SEE NOTES
title: FULL METAL π -FILTER ADAPTER PLUG / SOCKET 9-37pos. with hex bolts - 4-40 UNC and spring rings	title: FULL METAL π -FILTER ADAPTER PLUG / SOCKET 9-37pos. with hex bolts - 4-40 UNC and spring rings
dwg no: AutoCAD 2000	DIN-A
24K1A359	3
part no: SEE TABLE	sh: 1/1