

JBXE3C

MASS (g)	VOLUME (mm ³)
25.6	5196

ELECTRICAL :
 EMI SHIELDING : SHIELDED FOR THE RANGE 55dB UP TO 100MHz
 INSULATION RESISTANCE : >500MΩ PER ANSI-EIA-364-D METHOD 21
 MAX. CURRENT RATING : SEE INSULATOR DRAWING
 CONNECTOR TESTING : SEE INSULATOR DRAWING
 VOLTAGE
 CONNECTOR WORKING : SEE INSULATOR DRAWING
 VOLTAGE
ENVIRONMENTAL :
 ENDURANCE: 1000 CYCLES AS PER MIL-STD 1344A, METHOD 2016.1
 SHOCK: 50 g , DURATION 6 ms; AS PER MIL-STD 1344A, METHOD 2004.1
 VIBRATIONS: 10 TO 2000Hz g = 20g, AS PER MIL-STD 1344A, METHOD 2005.1
 PROTECTION INDEX: IP 40 AS PER IEC 529
 ROHS COMPLIANT
 SALT MIST : 48hr PER SAE AS 1344 METHOD 1001.1 CEI 529
 OPERATING TEMPERATURE: -55°C TO +125°C (-67°F TO +257°F)

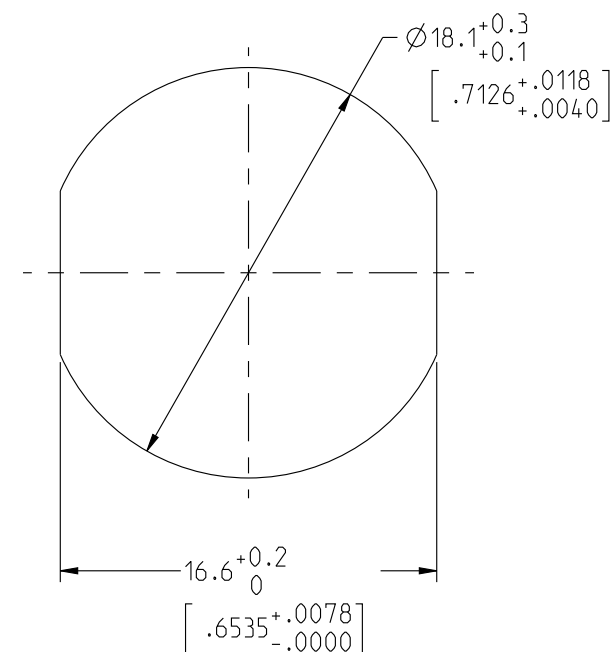

RECOMMENDED PANEL CUTOUT

NOTES:
MATERIAL:
 OUTER SHELL & PANEL NUT : BRASS
 SHIELD RING & NUT :
FINISH:
 OUTER SHELL & PANEL NUT : CHROME
 OTHER BRASS PARTS : NICKEL
TOOLS

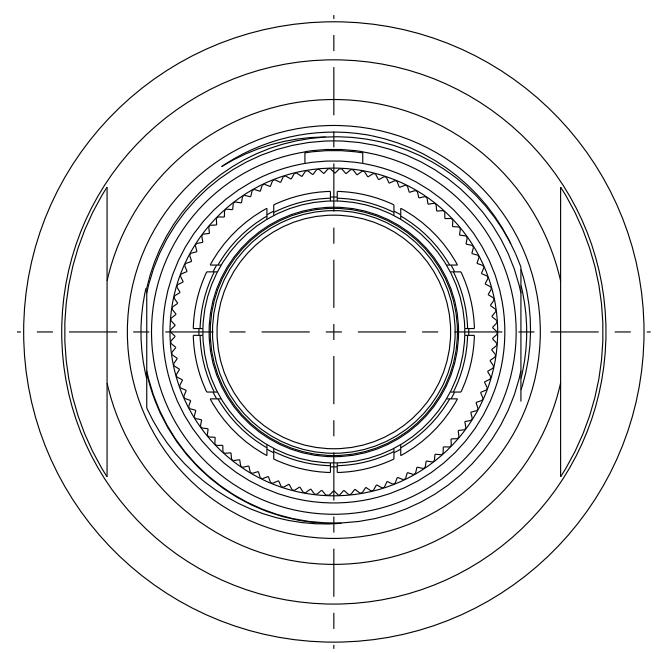

MATING SIDE VIEW

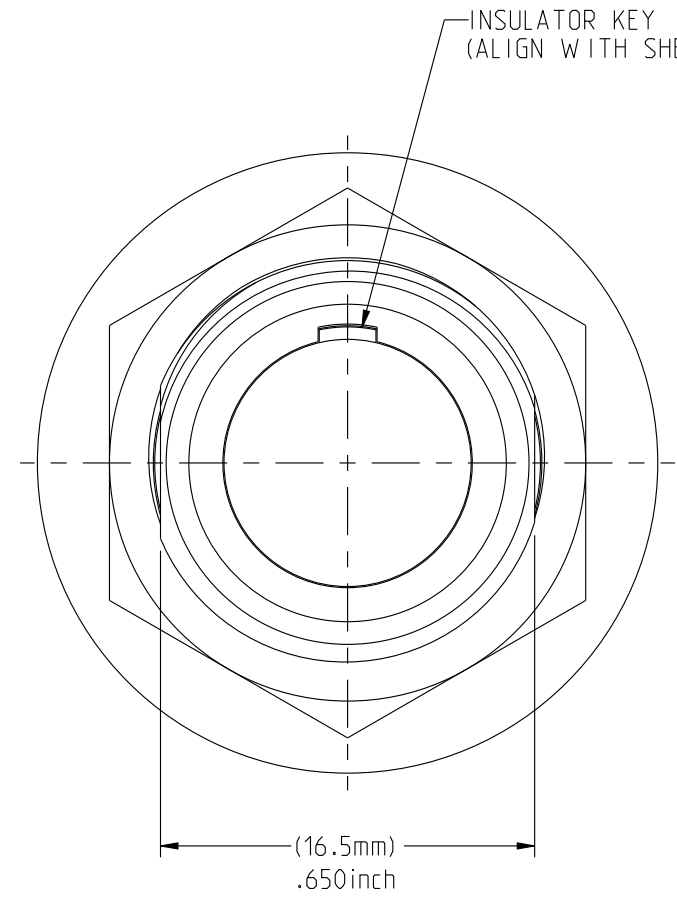
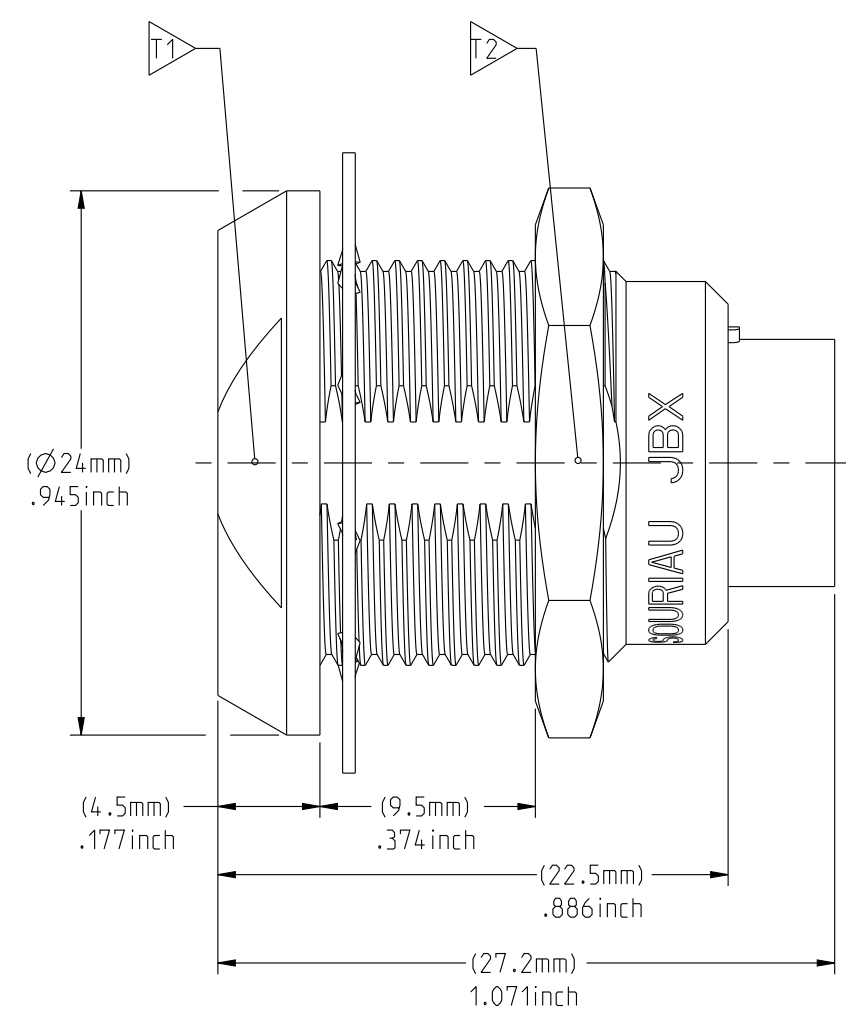

WIRE SIDE VIEW

PART LIST	
ITEM NO.	DESCRIPTION
1	SHELL
2	PANEL NUT
3	HEX NUT
4	INSULATOR
5	LOCK WASHER

	TOOLS (JAW DIMENSION)	ADVISED TORQUE IN Nm
T1	20	2
T2	21	2

CATALOG NUMBER DESCRIPTION

JBX EA 3 XXXXXDX -

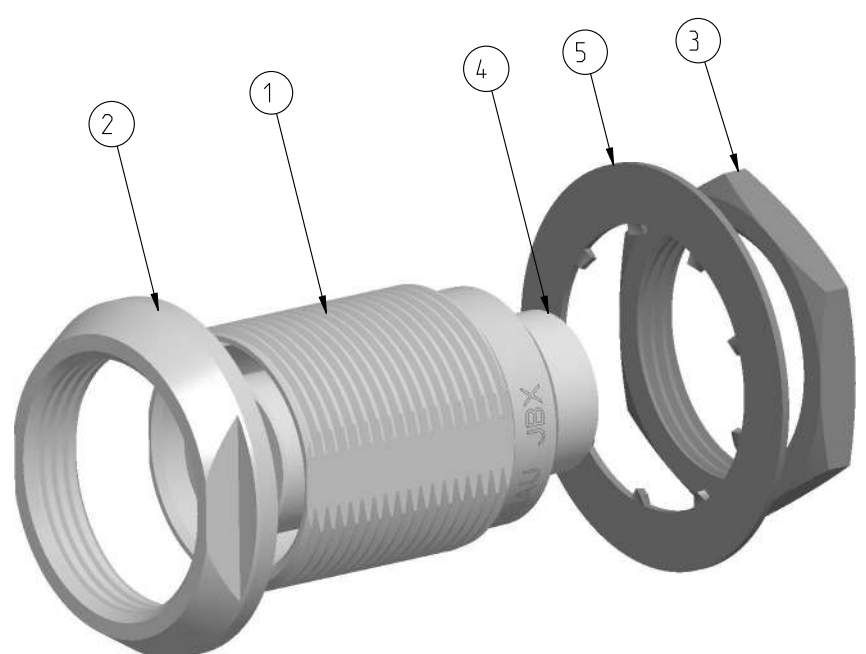
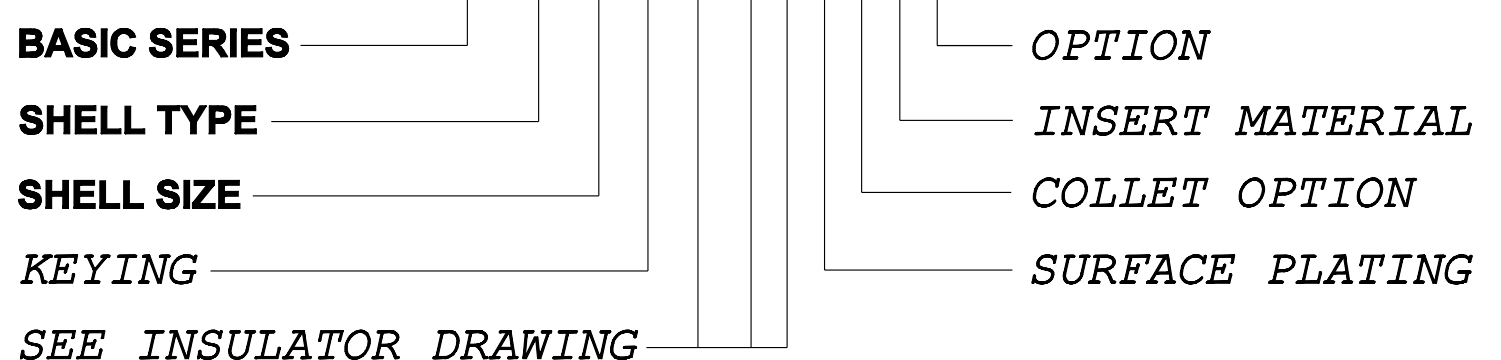

SCALE 2:1

ORIGIN	COUNTRY	JURISDICTION	CLASSIFICATION
X	FR	Not listed	N/A
	US	EAR	ECCN =EAR99

These commodities, technology or software are exported from the United States in accordance with the Export Administration Regulations, Diversion contrary to U.S. law is prohibited.

LINEAR MEASURE: $\frac{mm}{INCH}$ $\frac{mm}{(INCH)}$

THIRD ANGLE PROJECTION

TOLERANCES UNLESS OTHERWISE SPECIFIED

No. OF PLACES	mm [INCH]
WHOLE No.	±0.5 [±.02]
ONE PLACE	±0.2 [±.008]
TWO PLACES	±0.1 [±.004]

ANGLES ±1°

DRAWING TITLE
JBX SIZE 3, DOUBLE NUT RECEPTACLE

CAT NO. **JBXE3C**

CAGE NO: 09922 SIZE: C

CUSTOMER

INTERPRET THIS DRAWING IN ACCORDANCE WITH ASME Y14.5M - 1994.

SOURIAU
 WWW.SOURIAU.COM

APPROVAL

DRAWN: TJS	01-07-15
CHKD : EV	01-07-15
DSGN : EV	01-07-15
MFG : DH	01-07-15
QC : BB	01-07-15

DRAWING SCALE: 3:1

DRAWING NO. **JBXE3C** REV **A**

1 OF 1

THE INFORMATION CONTAINED IN THIS DRAWING IS CONFIDENTIAL AND MAY NOT BE DISCLOSED WITHOUT WRITTEN CONSENT FROM SOURIAU USA, INC.

THIS DRAWING IS A CONTROLLED DOCUMENT FOR SOURIAU USA, INC. IT IS SUBJECT TO CHANGE WITHOUT NOTIFICATION. CONTACT THE DOCUMENT CONTROL CENTER FOR THE LATEST REVISION.

DWG. NO.
JBX3INSFPC

FEMALE INSULATOR, PCB CONTACT

CONTACT LAYOUT	10	14
FRONT SIDE VIEW		
REAR SIDE VIEW		
CONTACT		
ISO VIEW		

CONTACT	$\varnothing C$	1.3	0.9
	$\varnothing F$	0.7	0.7
	MAX. AWG	-	-
	MAX. CURRENT RATING (A)	15	10
INSULATOR	CONTACT RESISTANCE (m Ω)	3.5	3.5
	NUMBER OF CAVITY	10	14
	MAX. CURRENT RATING	12	9
	TEST VOLTAGE (V _{rms})	1400	1700
WORKING VOLTAGE (V _{dc} /V _{rms})	600/420	830/560	

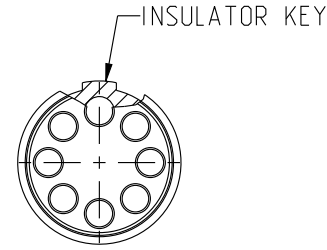

CONTACT TYPE : F (FEMALE)
CONTACT TERMINATION : P (PCB)
MATERIAL :
 CONTACT: CUPRO-NICKEL
 INSULATOR: PEEK
FINISH :
 CONTACTS : GOLD

CATALOG NUMBER DESCRIPTION

JBXXX 3 XYYFP XXXX

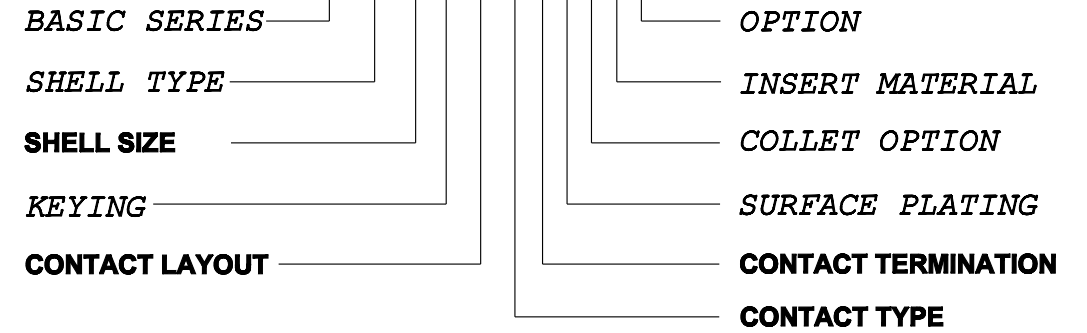

THIS DRAWING IS A CONTROLLED DOCUMENT FOR SOURIAU USA, INC. IT IS SUBJECT TO CHANGE WITHOUT NOTIFICATION. CONTACT THE DOCUMENT CONTROL CENTER FOR THE LATEST REVISION.

THE INFORMATION CONTAINED IN THIS DRAWING IS CONFIDENTIAL AND MAY NOT BE DISCLOSED WITHOUT WRITTEN CONSENT FROM SOURIAU USA, INC.

B

A

B	REVISED PER ECN 12286	RSK 06-10-15	EV 06-10-15
A	RELEASED PER ECN 12264	TJS 03-10-15	EV 03-10-15
REV	DESCRIPTION	BY DATE	CHKD DATE

DRAWING TITLE JBX, SIZE 3, FEMALE INSULATOR, PCB CONTACT	
CAT NO. JBX3INSFP	
CAGE NO: 09922	SIZE: B
CUSTOMER	SOURIAU
INTERPRET THIS DRAWING IN ACCORDANCE WITH ASME Y14.5M - 1994.	WWW.SOURIAU.COM
APPROVAL	DRAWN: TJS 02-04-15 CHKD : EV 02-04-15 DSGN : EV 02-04-15 MFG : DH 02-04-15 QC : BB 02-04-15
	DRAWING SCALE: NA
	DRAWING NO. REV
	JBX3INSFPC B
	1 OF 3

LINEAR MEASURE: $\frac{mm}{INCH}$ mm (INCH)

THIRD ANGLE PROJECTION

TOLERANCES UNLESS OTHERWISE SPECIFIED

No. OF PLACES	mm [INCH]
ONE PLACE	$\pm 3 [\pm .1]$
TWO PLACES	$\pm 0.5 [\pm .02]$
THREE PLACES	$\pm 0.25 [\pm .010]$

ANGLES $\pm 1^\circ$

ORIGIN	COUNTRY	JURISDICTION	CLASSIFICATION
X	FR	Not listed	N/A
	US	EAR	ECCN =EAR99

These commodities, technology or software are exported from the United States in accordance with the Export Administration Regulations. Diversion contrary to U.S. law is prohibited.

DWG. NO.
JBX3INSFPC

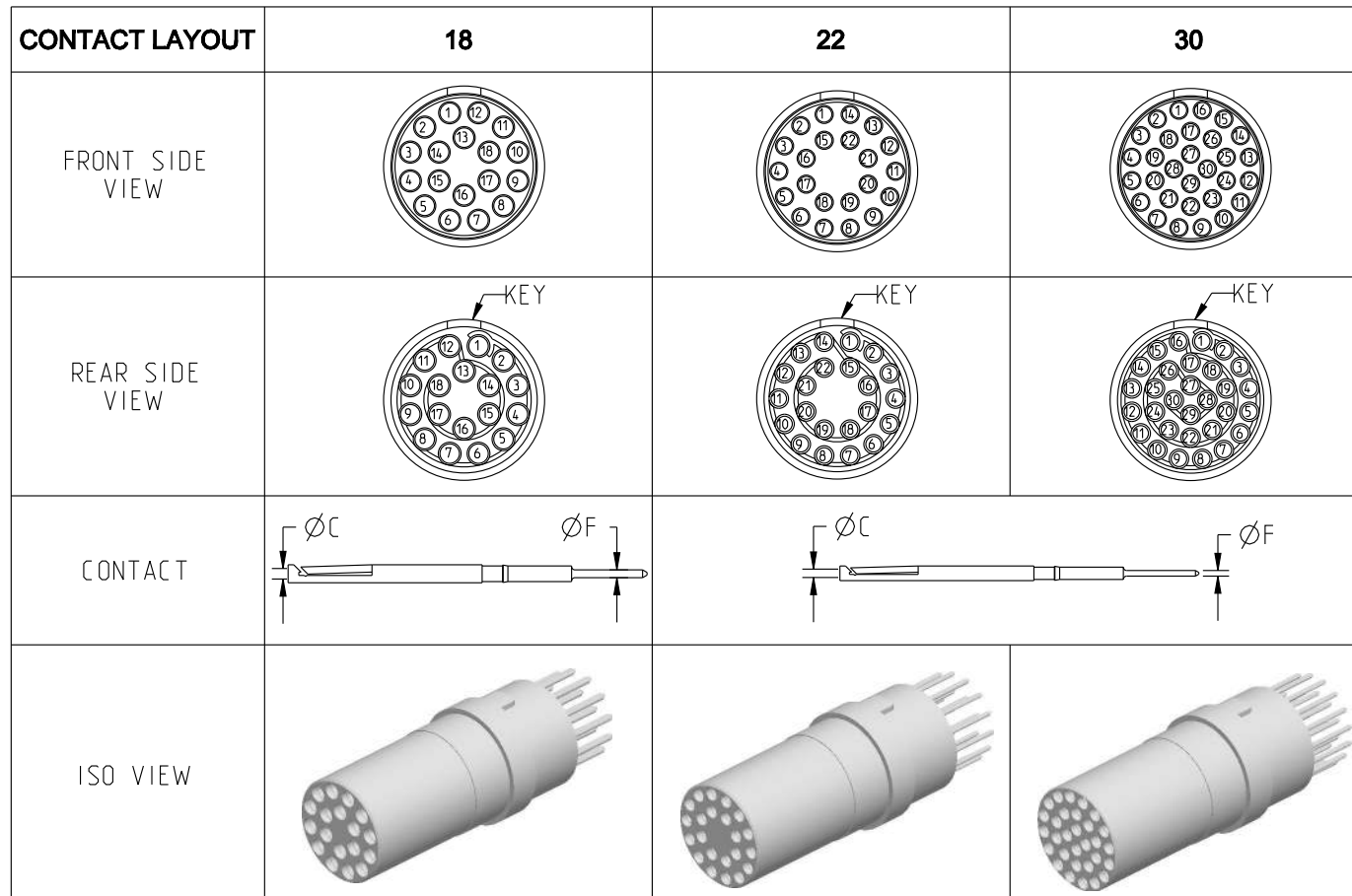

CONTACT	ØC	0.9	0.7	0.7
	ØF	0.7	0.5	0.5
	MAX. AWG	-	-	-
	MAX. CURRENT RATING (A)	10	7	7
INSULATOR	CONTACT RESISTANCE (mΩ)	3.5	5	5
	NUMBER OF CAVITY	18	22	30
	MAX. CURRENT RATING	7	5.5	3.5
	TEST VOLTAGE (Vrms)	1400	1200	800
	WORKING VOLTAGE (Vdc/Vrms)	660/460	560/400	400/260

THIS DRAWING IS A CONTROLLED DOCUMENT FOR SOURIAU USA, INC. IT IS SUBJECT TO CHANGE WITHOUT NOTIFICATION. CONTACT THE DOCUMENT CONTROL CENTER FOR THE LATEST REVISION.

THE INFORMATION CONTAINED IN THIS DRAWING IS CONFIDENTIAL AND MAY NOT BE DISCLOSED WITHOUT WRITTEN CONSENT FROM SOURIAU USA, INC.

B

A

DRAWING TITLE		JBX, SIZE 3, FEMALE INSULATOR, PCB CONTACT	
CAT NO.		JBX3INSFP	
CAGE NO: 09922	SIZE: B		
CUSTOMER	SOURIAU	APPROVAL	DRAWN: TJS 02-04-15
			CHKD : EV 02-04-15
			DSGN : EV 02-04-15
			MFG : DH 02-04-15
			QC : BB 02-04-15
INTERPRET THIS DRAWING IN ACCORDANCE WITH ASME Y14.5M - 1994.		DRAWING SCALE: NA	
		DRAWING NO.	REV
		JBX3INSFPC	B
		2 OF 3	
		PRO-E	

LINEAR MEASURE: $\frac{mm}{INCH}$ mm (INCH)

THIRD ANGLE PROJECTION

TOLERANCES UNLESS OTHERWISE SPECIFIED

No. OF PLACES	mm [INCH]
ONE PLACE	±3 [±.1]
TWO PLACES	±0.5 [±.02]
THREE PLACES	±0.25 [±.010]

ANGLES ±1°

ORIGIN	COUNTRY	JURISDICTION	CLASSIFICATION
X	FR	Not listed	N/A
	US	EAR	ECCN =EAR99

These commodities, technology or software are exported from the United States in accordance with the Export Administration Regulations. Diversion contrary to U.S. law is prohibited

DWG. NO.
JBX3INSFPC

THIS DRAWING IS A CONTROLLED DOCUMENT FOR SOURIAU USA, INC. IT IS SUBJECT TO CHANGE WITHOUT NOTIFICATION. CONTACT THE DOCUMENT CONTROL CENTER FOR THE LATEST REVISION.

THE INFORMATION CONTAINED IN THIS DRAWING IS CONFIDENTIAL AND MAY NOT BE DISCLOSED WITHOUT WRITTEN CONSENT FROM SOURIAU USA, INC.

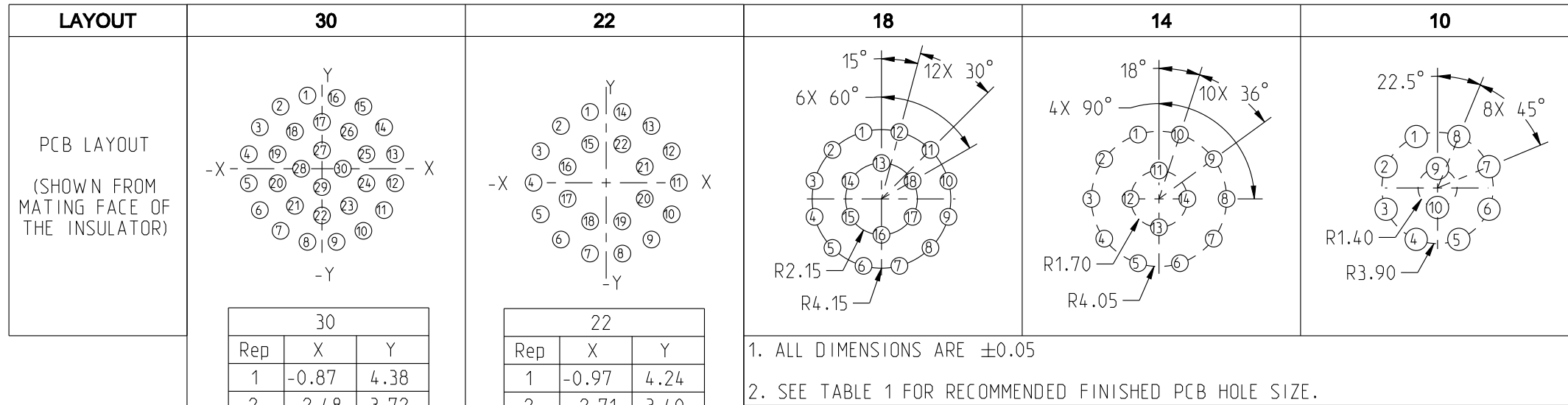

CONTACT PCB TAIL SIZE DIA	FINISHED PCB HOLE SIZE DIA
0.5	0.75
0.7	0.95

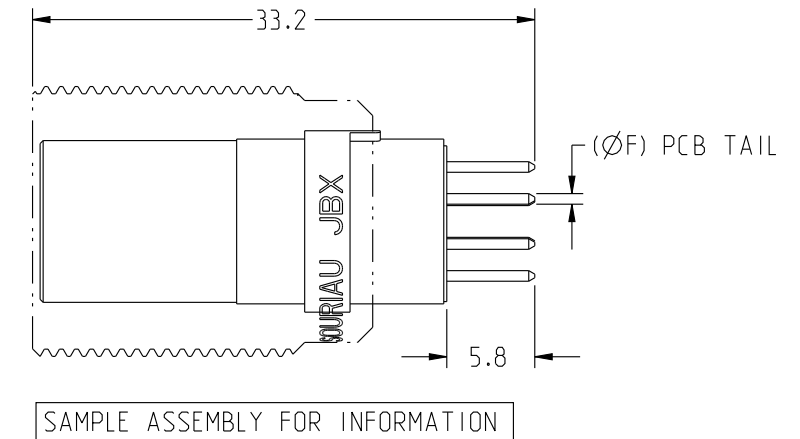

ORIGIN	COUNTRY	JURISDICTION	CLASSIFICATION
X	FR	Not listed	N/A
	US	EAR	ECCN =EAR99

These commodities, technology or software are exported from the United States in accordance with the Export Administration Regulations. Diversion contrary to U.S. law is prohibited.

LINEAR MEASURE: $\frac{mm}{INCH}$ mm (INCH)

THIRD ANGLE PROJECTION

TOLERANCES UNLESS OTHERWISE SPECIFIED

No. OF PLACES	mm [INCH]
ONE PLACE	$\pm 3 [\pm .1]$
TWO PLACES	$\pm 0.5 [\pm .02]$
THREE PLACES	$\pm 0.25 [\pm .010]$

ANGLES $\pm 1^\circ$

DRAWING TITLE
JBX, SIZE 3, FEMALE INSULATOR, PCB CONTACT

CAT NO. **JBX3INSFPC**

CAGE NO: 09922 SIZE: B

CUSTOMER

SOURIAU

WWW.SOURIAU.COM

INTERPRET THIS DRAWING IN ACCORDANCE WITH ASME Y14.5M - 1994.

APPROVAL	DRAWN:	TJS	02-04-15
	CHKD :	EV	02-04-15
	DSGN :	EV	02-04-15
	MFG :	DH	02-04-15
	QC :	BB	02-04-15
	DRAWING SCALE: NA		
	DRAWING NO.	REV	
	JBX3INSFPC	B	
	3 OF 3		