

## LDC0851 Differential Inductive Switch

### 1 Features

- Threshold tolerance: <1 % of coil diameter
- Temperature stable switching operation
- Average Supply Current: < 20  $\mu$ A @ 10 sps
- Shutdown Supply Current: 140 nA
- Push-pull output
- Resistor Programmable Threshold
- Insensitive to DC Magnetic Fields
- Contactless Switching Operation
- Sample Rate up to 4 ksp/s
- Supply Voltage: 1.8 V – 3.3 V
- Operating Temperature Range: -40 to 125 °C

### 2 Applications

- Open/Close Switches
  - Home Security and Tamper Detection
  - Printers
  - Personal Electronics
- Event Counting
  - Fan Speed RPM Detection
  - Rotary Encoder
  - Flow Meters
  - Incremental Knob / Dial
- Simple Buttons
  - Industrial Keypads
  - Personal Electronics
- Industrial Proximity Switch

### 3 Description

The LDC0851 is a close range inductive switch ideal for contactless and robust applications such as presence detection, event counting, and simple buttons.

The switch is triggered when a conductive object comes within close proximity of the sensing coil. Hysteresis is included to ensure a reliable switching threshold immune to mechanical vibration. The differential implementation prevents false triggering over environmental factors such as temperature variation or humidity effects.

Inductive sensing technology provides reliable and accurate sensing even in the presence of dirt, oil, or moisture making it ideal for use in harsh or dirty environments. The solid state switching eliminates the failures due to reed, mechanical, or contact switching. Unlike competitive products, the LDC0851 does not require magnets, nor is it affected by DC magnetic fields.

#### Device Information<sup>(1)</sup>

PART NUMBER	PACKAGE	BODY SIZE (NOM)
LDC0851	WSO8-8	2mm x 2mm

(1) For all available packages, see the orderable addendum at the end of the data sheet.

### 4 Simplified Schematic

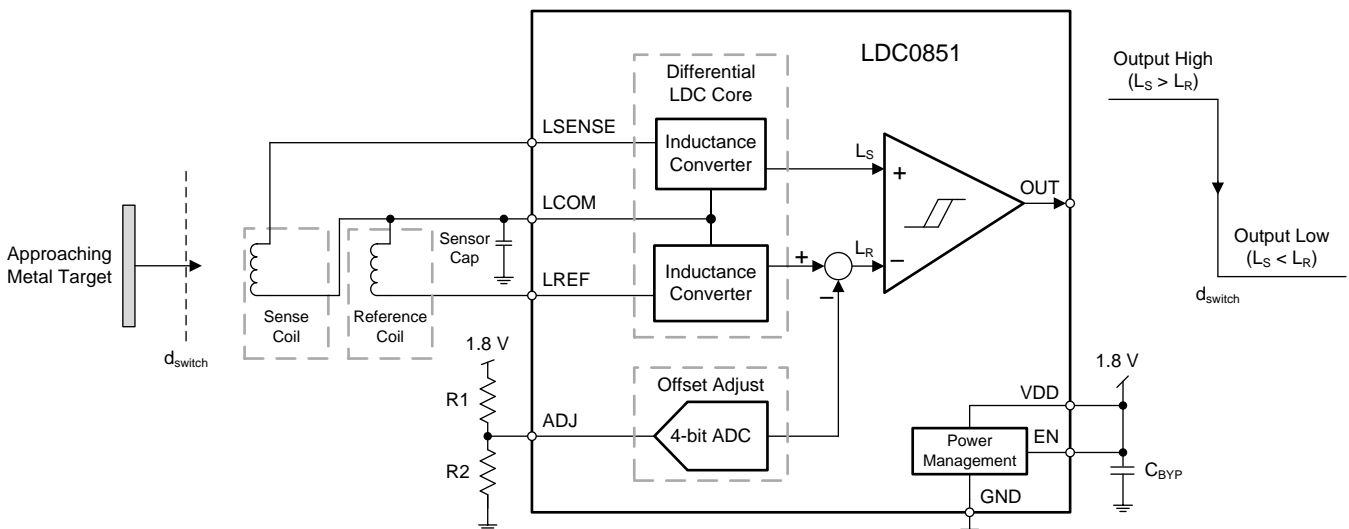

## Table of Contents

<b>1 Features</b> .....	1	8.2 Functional Block Diagram .....	10
<b>2 Applications</b> .....	1	8.3 Feature Description .....	11
<b>3 Description</b> .....	1	8.4 Device Functional Modes .....	18
<b>4 Simplified Schematic</b> .....	1	<b>9 Application and Implementation</b> .....	19
<b>5 Revision History</b> .....	2	9.1 Application Information .....	19
<b>6 Pin Configuration and Functions</b> .....	3	9.2 Typical Application .....	21
<b>7 Specifications</b> .....	4	<b>10 Power Supply Recommendations</b> .....	28
7.1 Absolute Maximum Ratings .....	4	<b>11 Layout</b> .....	29
7.2 ESD Ratings .....	4	11.1 Layout Guidelines .....	29
7.3 Recommended Operating Conditions .....	4	11.2 Layout Example .....	29
7.4 Thermal Information .....	4	<b>12 Device and Documentation Support</b> .....	31
7.5 Electrical Characteristics .....	5	12.1 Device Support .....	31
7.6 Interface Voltage Levels .....	5	12.2 Community Resources .....	31
7.7 Timing Requirements .....	6	12.3 Trademarks .....	31
7.8 Typical Characteristics .....	7	12.4 Electrostatic Discharge Caution .....	31
<b>8 Detailed Description</b> .....	10	12.5 Glossary .....	31
8.1 Overview .....	10	<b>13 Mechanical, Packaging, and Orderable Information</b> .....	31

## 5 Revision History

### Changes from Original (December 2015) to Revision A

Page

• Product Preview to Production Data Release .....	1
--	---

## 6 Pin Configuration and Functions

**DSG Package  
8-Pin WSON with DAP  
Top View**

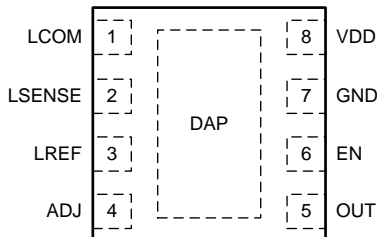

**Pin Functions**

PIN		TYPE <sup>(1)</sup>	DESCRIPTION
NAME	NO.		
LCOM	1	A	Common coil input
LSENSE	2	A	Sense coil input
LREF	3	A	Reference coil input
ADJ	4	A	Threshold adjust pin
OUT	5	O	Switch output
EN	6	I	Enable input
GND	7	G	Ground
VDD	8	P	Power Supply
DAP	DAP	G	Connect to Ground for improved thermal performance <sup>(2)</sup>

(1) I = Input, O = Output, P = Power, A = Analog, G = Ground

(2) There is an internal electrical connection between the exposed Die Attach Pad (DAP) and the GND pin of the device. Although the DAP can be left floating, for best performance the DAP should be connected to the same potential as the device's GND pin. Do not use the DAP as the primary ground for the device. The device GND pin must always be connected to ground.

## 7 Specifications

### 7.1 Absolute Maximum Ratings

over operating free-air temperature range (unless otherwise noted) <sup>(1)</sup>

		MIN	MAX	UNIT
V <sub>DD</sub>	Supply Voltage Range		3.6	V
V <sub>i</sub>	Voltage on LSENSE, LREF, and EN	-0.3	3.6	V
	Voltage on ADJ and LCOM	-0.3	2	V
I <sub>A</sub>	Current LSENSE, LREF, and VOUT		5	mA
T <sub>J</sub>	Junction Temperature	-55	150	°C
T <sub>stg</sub>	Storage Temperature	-65	150	°C

- (1) Stresses beyond those listed under *Absolute Maximum Ratings* may cause permanent damage to the device. These are stress ratings only, which do not imply functional operation of the device at these or any other conditions beyond those indicated under *Recommended Operating Conditions*. Exposure to absolute-maximum-rated conditions for extended periods may affect device reliability.

### 7.2 ESD Ratings

			VALUE	UNIT
V <sub>(ESD)</sub>	Electrostatic discharge	Human-body model (HBM), per ANSI/ESDA/JEDEC JS-001 <sup>(1)</sup>	±1000	V
		Charged-device model (CDM), per JEDEC specification JESD22-C101 <sup>(2)</sup>	±250	

- (1) JEDEC document JEP155 states that 500-V HBM allows safe manufacturing with a standard ESD control process.

- (2) JEDEC document JEP157 states that 250-V CDM allows safe manufacturing with a standard ESD control process.

### 7.3 Recommended Operating Conditions

over operating free-air temperature range (unless otherwise noted)

		MIN	NOM	MAX	UNIT
V <sub>DD</sub>	Supply Voltage	1.71		3.46	V
T <sub>A</sub>	Operating Temperature	-40		125	°C

### 7.4 Thermal Information

over operating free-air temperature range (unless otherwise noted)

THERMAL METRIC <sup>(1)</sup>		LDC0851	UNIT
		DSG (WSON)	
		8 PINS	
R <sub>θJA</sub>	Junction-to-ambient thermal resistance	67.4	°C/W
R <sub>θJC(top)</sub>	Junction-to-case (top) thermal resistance	89.3	°C/W
R <sub>θJB</sub>	Junction-to-board thermal resistance	37.3	°C/W
ψ <sub>JT</sub>	Junction-to-top characterization parameter	2.4	°C/W
ψ <sub>JB</sub>	Junction-to-board characterization parameter	37.7	°C/W
R <sub>θJC(bot)</sub>	Junction-to-case (bottom) thermal resistance	9.2	°C/W

- (1) For more information about traditional and new thermal metrics, see the *Semiconductor and IC Package Thermal Metrics* application report (SPRA953).

## 7.5 Electrical Characteristics<sup>(1)</sup>

Over recommended operating conditions unless otherwise noted.  $V_{DD} = 3.3\text{ V}$ , EN tied to 3.3 V,  $T_A = 25\text{ }^\circ\text{C}$ , ADJ tied to GND.

PARAMETER		TEST CONDITIONS	MIN <sup>(2)</sup>	TYP <sup>(3)</sup>	MAX <sup>(2)</sup>	UNIT
<b>POWER</b>						
$V_{DD}$	Supply Voltage		1.71		3.46	V
$I_{STATIC}$	Static Supply Current <sup>(4)</sup>			0.70		mA
$I_{DYN}$	Dynamic Supply Current (not including sensor current) <sup>(4)</sup>	$f_{SENSOR} = 15\text{ MHz}$ $C_{PARASITIC} = 22\text{ pF}$		0.66		mA
$I_{SD}$	Shutdown Mode Supply Current			0.14	1	$\mu\text{A}$
<b>SENSOR</b>						
$I_{SENSOR\_MAX}$	Maximum sensor current <sup>(4)</sup>	$V_{DD} = 1.71\text{ V}$	4.35			mA
		$V_{DD} = 3.3\text{ V}$	6			mA
$L_{SENSOR\_MIN}$	Sensor Minimum Inductance <sup>(5)</sup>	$C_{TOTAL} = 33\text{ pF}$ $V_{DD} = 1.71\text{ V}$	2.5			
		$C_{TOTAL} = 33\text{ pF}$ $V_{DD} = 3.3\text{ V}$	1.8			$\mu\text{H}$
$f_{SENSOR\_MAX}$	Max Sensor Resonant Frequency <sup>(5)</sup>	Sensor inductance = $2\text{ }\mu\text{H}$ $C_{TOTAL} = 33\text{ pF}$	19			MHz
$C_{TOTAL}$	Minimum total capacitance on LCOM <sup>(5)</sup> Includes parasitic pin capacitance and PCB parasitic capacitance		33			pF
$C_{IN}$	Pin parasitic capacitance on LCOM		12			pF
	Pin parasitic capacitance on LREF and LSENSE		8			pF
<b>DETECTION</b>						
$d_{HYST}$	Switching distance hysteresis <sup>(6)</sup>		2.5 %			
$d_{TOL}$	Switching threshold tolerance <sup>(6)</sup>		0.1 %			
<b>THRESHOLD ADJUST</b>						
$V_{ADJ}$	Adjust input range		0		$V_{DD}/2$	V
$V_{ADJ\_TOL}$	Adjust threshold tolerance		$\pm 6$			mV

- (1) Electrical Characteristics Table values apply only for factory testing conditions at the temperature indicated. Factory testing conditions result in very limited self-heating of the device such that  $T_J = T_A$ . No guarantee of parametric performance is indicated in the electrical tables under conditions of internal self-heating where  $T_J > T_A$ . Absolute Maximum Ratings indicate junction temperature limits beyond which the device may be permanently degraded, either mechanically or electrically.
- (2) Limits are ensured by testing, design, or statistical analysis at 25°C. Limits over the operating temperature range are ensured through correlations using statistical quality control (SQC) method.
- (3) Typical values represent the most likely parametric norm as determined at the time of characterization. Actual typical values may vary over time and will also depend on the application and configuration. The typical values are not tested and are not guaranteed on shipped production material.
- (4) Refer to section *Active Mode* for a description and calculation of the various supply currents.
- (5) See *Sensor Design* for sensor guidance.
- (6) Two matched 10 mm diameter sensors were used with a switching distance of 3 mm. See *Hysteresis* for more information.

## 7.6 Interface Voltage Levels

PARAMETER	MIN	TYP	MAX	UNIT
$V_{IH}$	Input High Voltage		$0.8 \times V_{DD}$	V
$V_{IL}$	Input Low Voltage		$0.2 \times V_{DD}$	V
$V_{OH}$	Output High Voltage (1mA source current)		$V_{DD} - 0.4$	V
$V_{OL}$	Output Low Voltage (1mA sink current)		0.4	V

### 7.7 Timing Requirements

Over recommended operating conditions unless otherwise noted.  $V_{DD} = 3.3\text{ V}$ , EN tied to 3.3 V,  $T_A = 25\text{ }^\circ\text{C}$ , ADJ tied to GND.

PARAMETER	TEST CONDITIONS	MIN	TYP	MAX	UNIT
<b>VOLTAGE LEVELS</b>					
$t_{CONVERSION}$	Conversion time	$f_{SENSOR} = 15\text{ MHz}$	290		$\mu\text{s}$
$t_{DELAY}$	Output delay time (Response time)	$f_{SENSOR} = 15\text{ MHz}$	580		$\mu\text{s}$
$t_{START}$	Start-up time		450		$\mu\text{s}$
$t_{AMT}$	Shutdown-to-active mode transition time		450		$\mu\text{s}$
$t_{SMT}$	Active-to-shutdown mode transition time		<1		$\mu\text{s}$

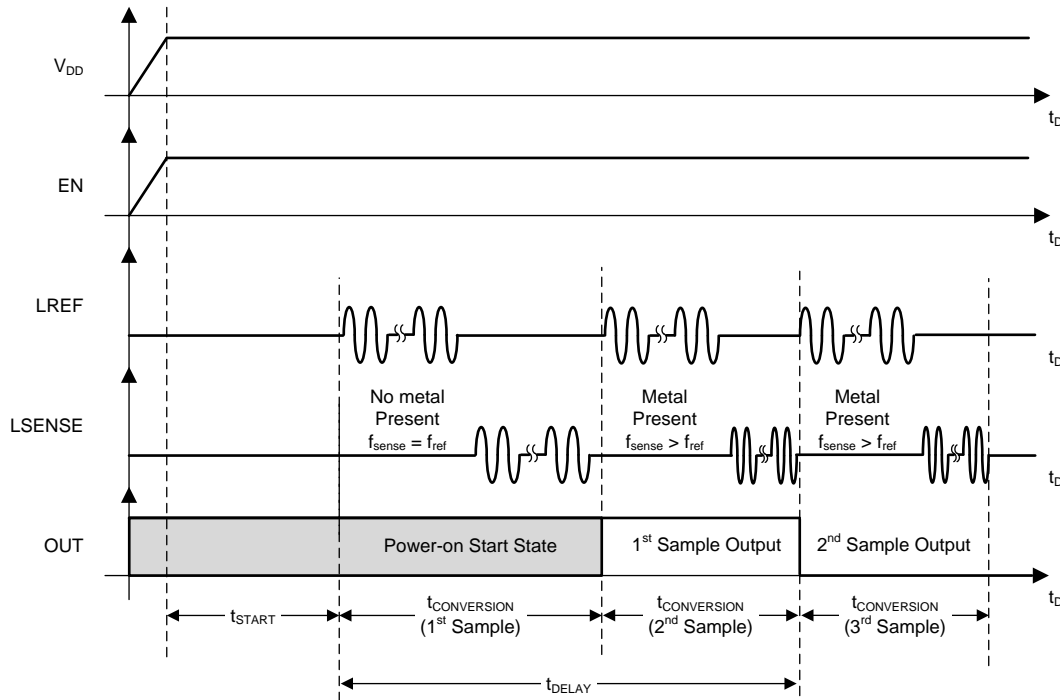

Figure 1. Start-up and Delay Time Diagram

Refer to [Power-Up Conditions](#) for more information on the Power-On Start State.

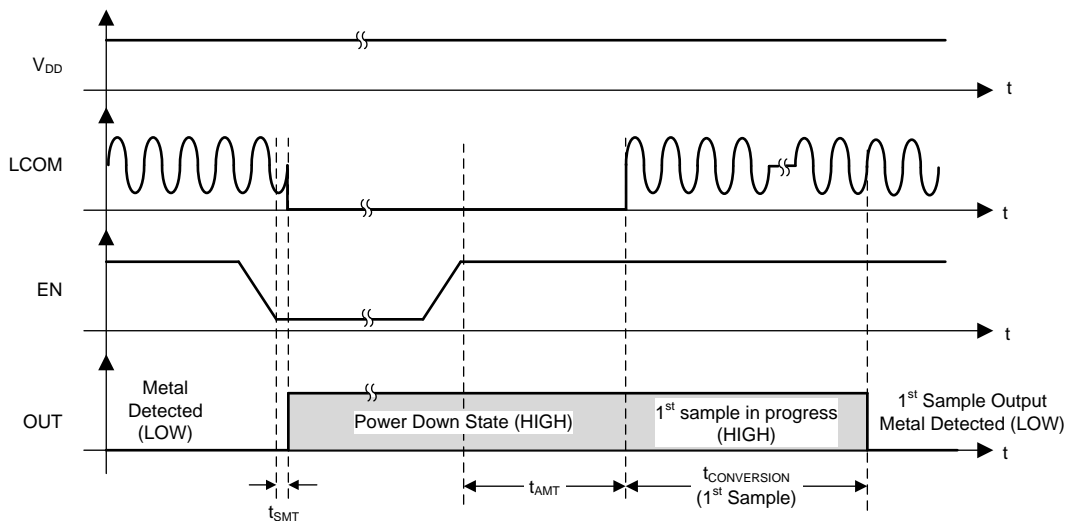

Figure 2. Shutdown and Resume Active Mode Timing Diagram

## 7.8 Typical Characteristics

Common test conditions (unless specified otherwise):  $V_{DD} = 3.3\text{ V}$ , Sense coil diameter = reference coil diameter, Target: Aluminum, 1.5 mm thickness, Target area / Coil area > 100%

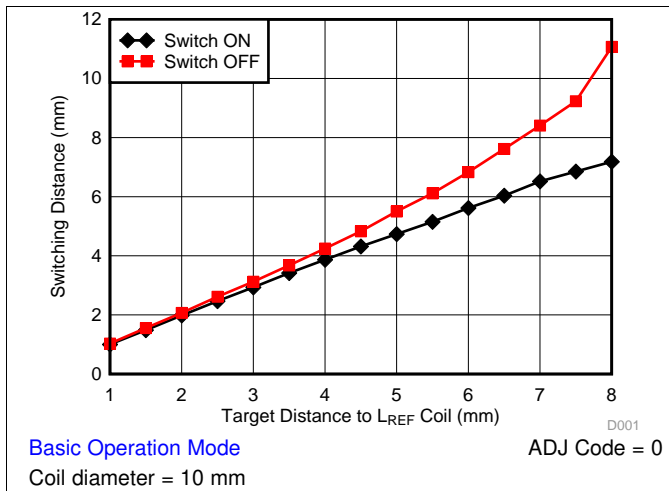

Figure 3. Switching Distance vs. LREF Target Distance

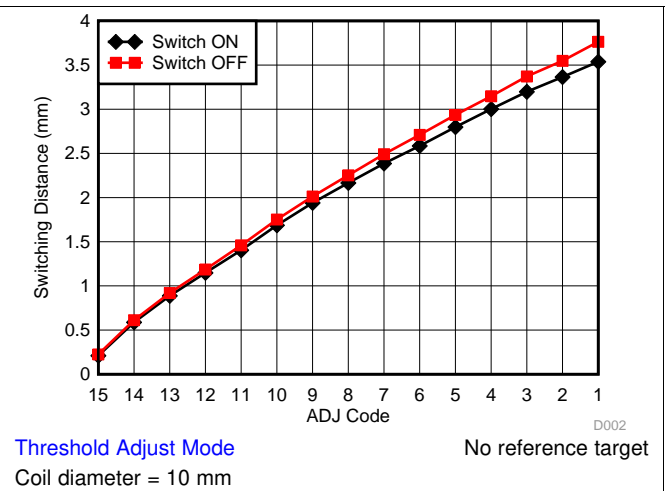

Figure 4. Switching Distance vs. ADJ code

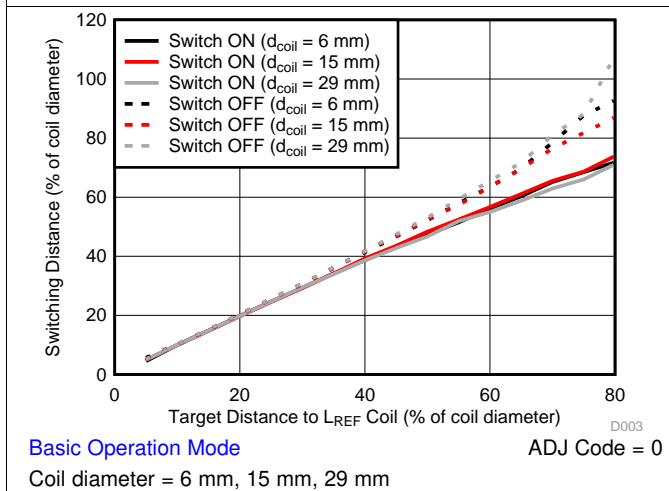

Figure 5. Normalized Switching Distance vs. LREF Target Distance

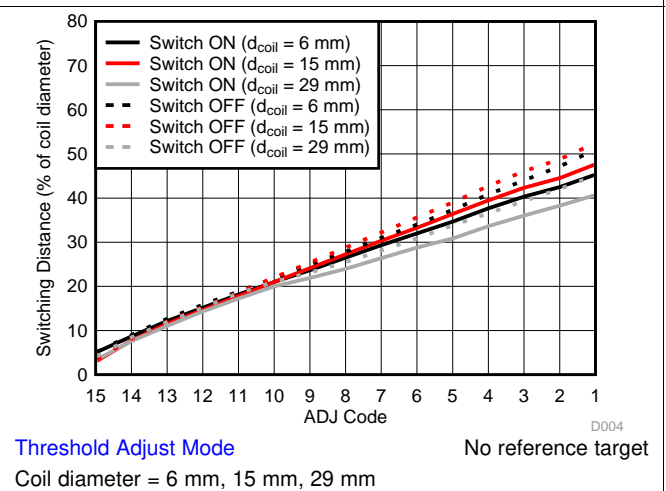

Figure 6. Normalized Switching Distance vs. ADJ Code

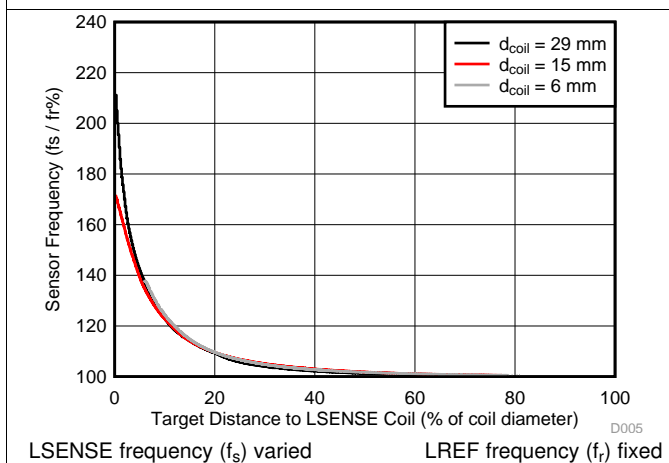

Figure 7. Frequency vs. Distance

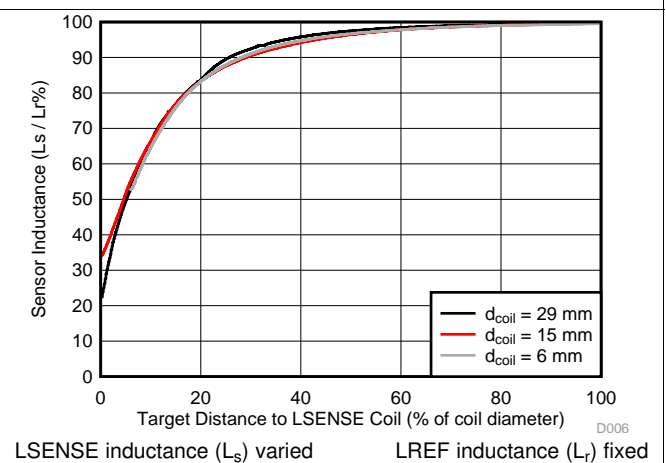

Figure 8. Inductance vs. Distance

Typical Characteristics (continued)

Common test conditions (unless specified otherwise):  $V_{DD} = 3.3\text{ V}$ , Sense coil diameter = reference coil diameter, Target: Aluminum, 1.5 mm thickness, Target area / Coil area > 100%

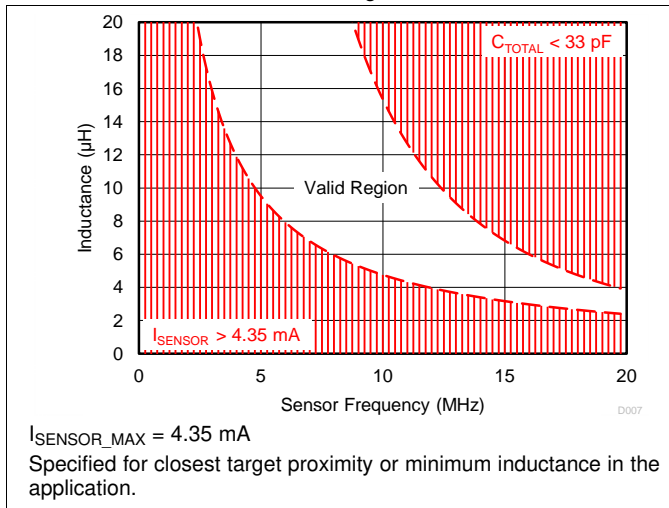

Figure 9. Sensor Design Space for  $V_{DD} = 1.8\text{ V}$

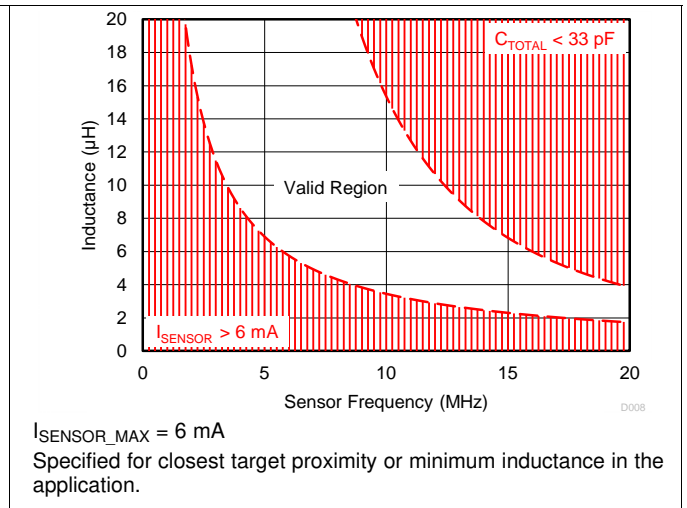

Figure 10. Sensor Design Space for  $V_{DD} = 3.3\text{ V}$

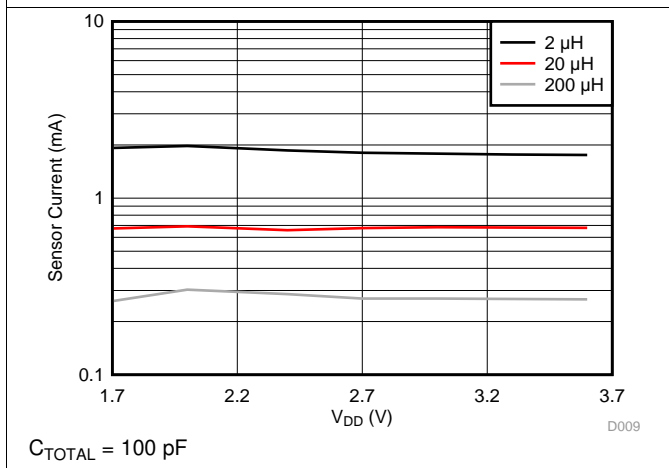

Figure 11.  $I_{\text{SENSOR}}$  vs.  $V_{DD}$

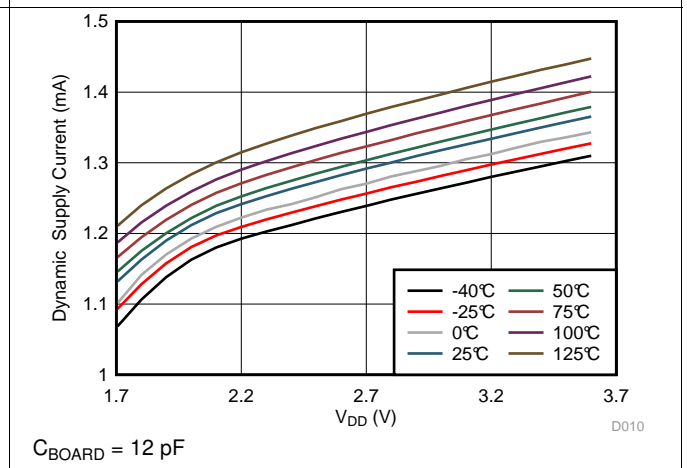

Figure 12.  $I_{\text{DYN}}$  vs.  $V_{DD}$

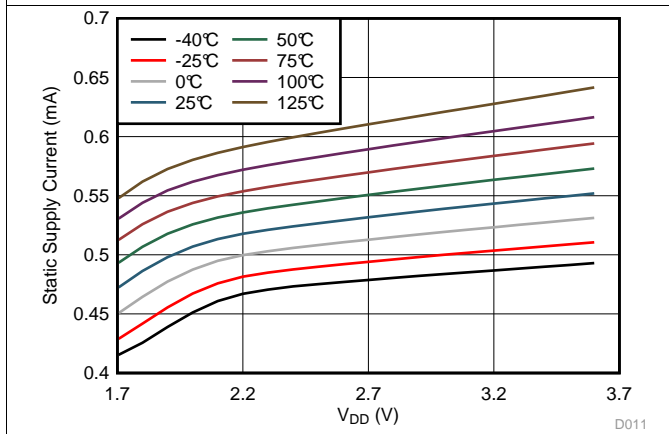

Figure 13.  $I_{\text{STATIC}}$  vs.  $V_{DD}$

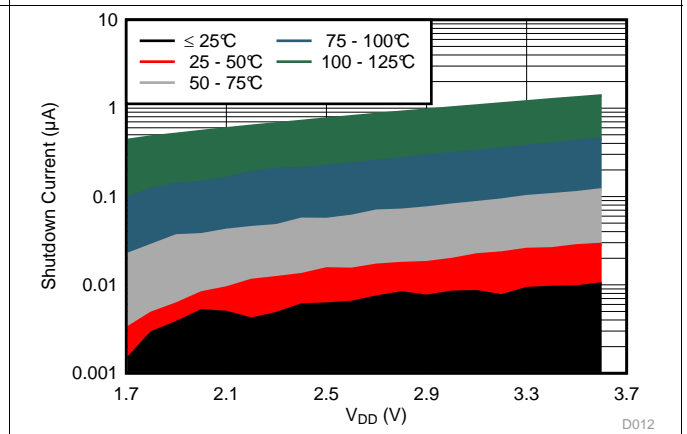
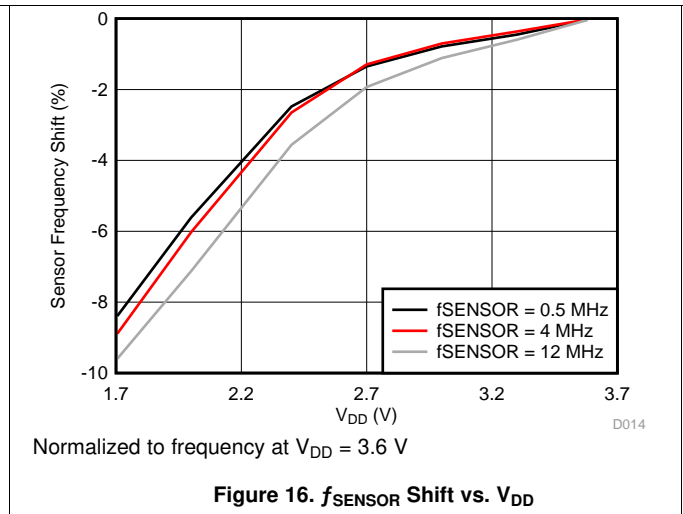
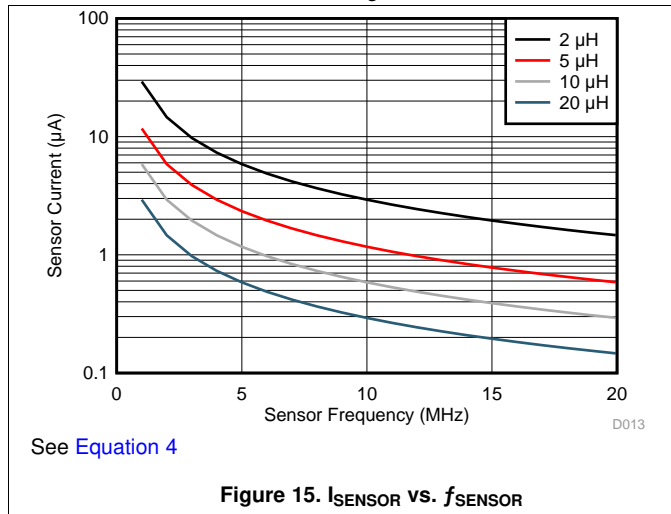

Figure 14.  $I_{\text{SD}}$  vs.  $V_{DD}$



**Typical Characteristics (continued)**

Common test conditions (unless specified otherwise):  $V_{DD} = 3.3\text{ V}$ , Sense coil diameter = reference coil diameter, Target: Aluminum, 1.5 mm thickness, Target area / Coil area > 100%



## 8 Detailed Description

### 8.1 Overview

The LDC0851 is an inductance comparator with push/pull output. It utilizes a sensing coil and a reference coil to determine the relative inductance in a system. The push/pull output (OUT) switches low when the sense inductance drops below the reference and returns high when the reference inductance is higher than the sense inductance. Matching the sense and reference coils is important to maintain a consistent switching distance over temperature and to compensate for other environmental factors. The LDC0851 features internal hysteresis to prevent false switching due to noise or mechanical vibration at the switching threshold. The switching threshold is set by the sensor characteristics and proximity to conductive objects, which is considered Basic Operation Mode described further in section [Basic Operation Mode](#). The LDC0851 also features a Threshold Adjust Mode where an offset is subtracted from the reference inductance to change the effective switching point as described in section [Threshold Adjust Mode](#).

The sensing coil is connected across the LSENSE and LCOM pins and the reference coil is connected across the LREF and LCOM pins. A sensor capacitor is connected from LCOM to GND to set the sensor oscillation frequency. The sensor capacitor is common to both LSENSE and LREF making the inductance measurement differential.

### 8.2 Functional Block Diagram

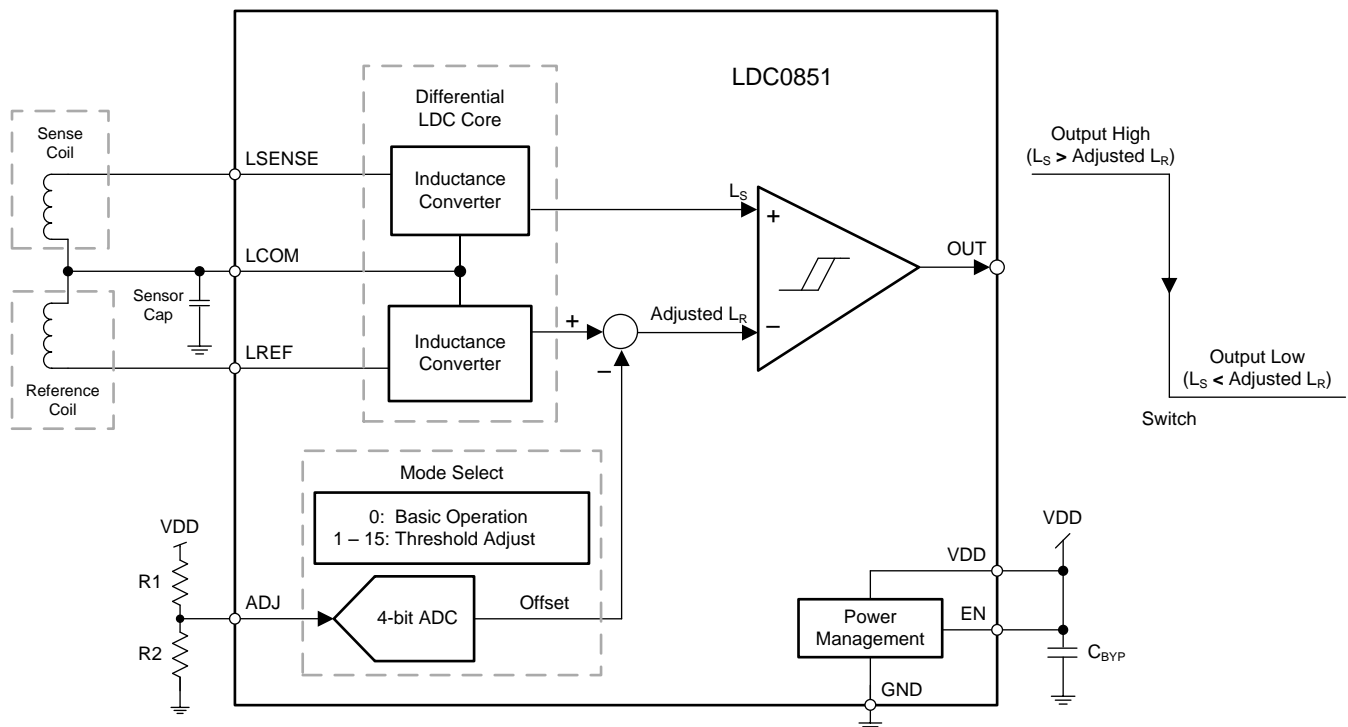

### 8.3 Feature Description

#### 8.3.1 Basic Operation Mode

The LDC0851 is configured for Basic Operation mode when the ADJ pin is tied to ground. Two identical coils should be used for LSENSE and LREF. The switching point occurs when the inductances of both coils are equal. Basic Operation mode can be used for a wide variety of applications including event counting or proximity sensing. An example showing gear tooth counting can be found in section [Event Counting](#).

For proximity sensing the switching point can be set by placing a conductive target at a fixed distance from the reference coil as shown in [Figure 17](#). The output will switch when a conductive target approaches LSENSE and reaches the same distance set by the fixed reference target. For reliable and repeatable switching it is recommended to place the reference target at a distance less than 40% of the coil diameter from the reference coil.

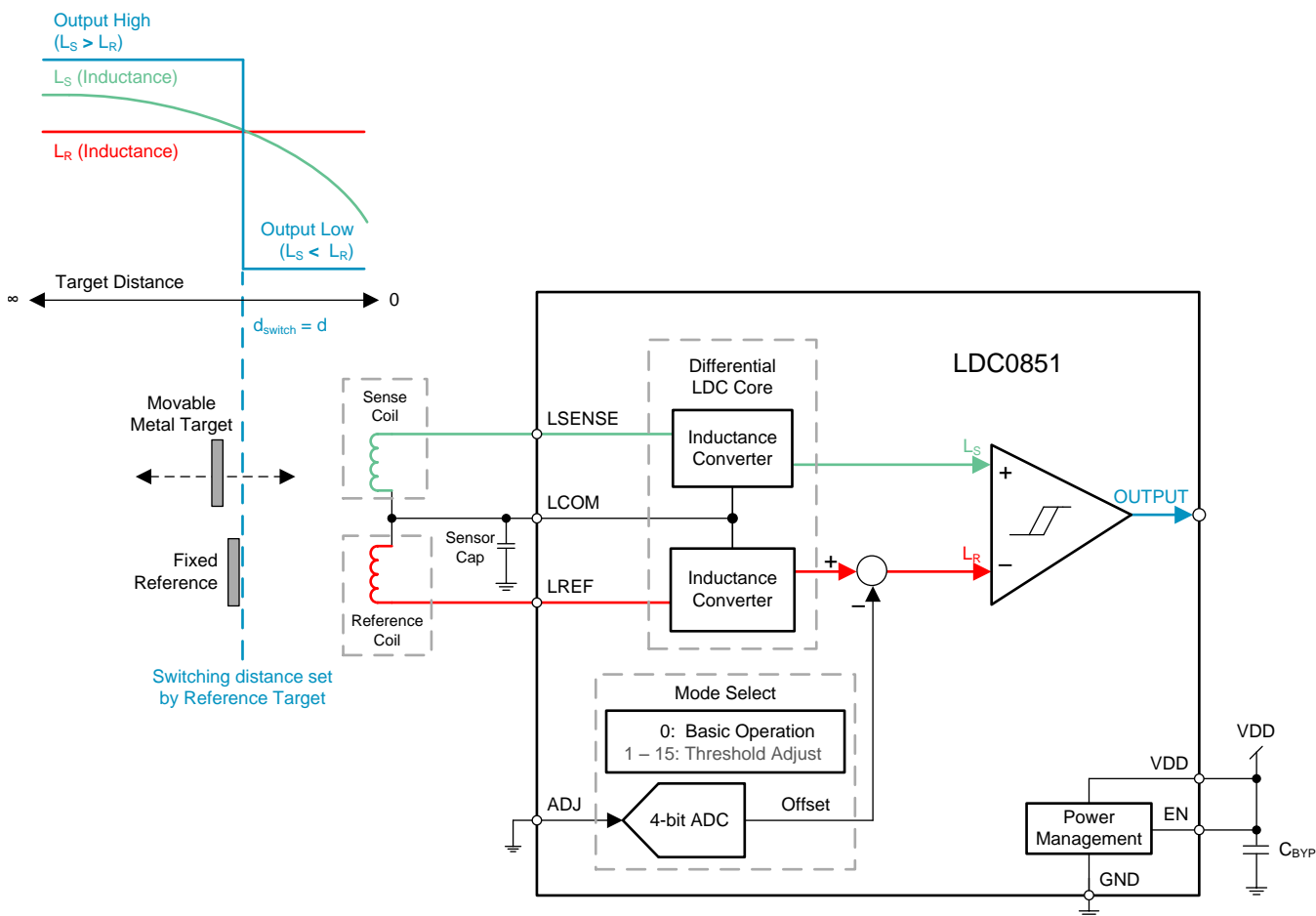

Figure 17. Basic Operation Mode Diagram for Distance Sensing With Reference Target

Feature Description (continued)

In some systems adding a reference target at a fixed height to set the switching distance is not feasible. Therefore to set the switching distance a small amount of mismatch between the sense and reference coils can be introduced. To achieve the maximum switching distance the reference inductance should be approximately 0.4% less than the sense inductance as shown in Figure 18 below. The 0.4% mismatch will ensure that the output will switch off when the target is removed.

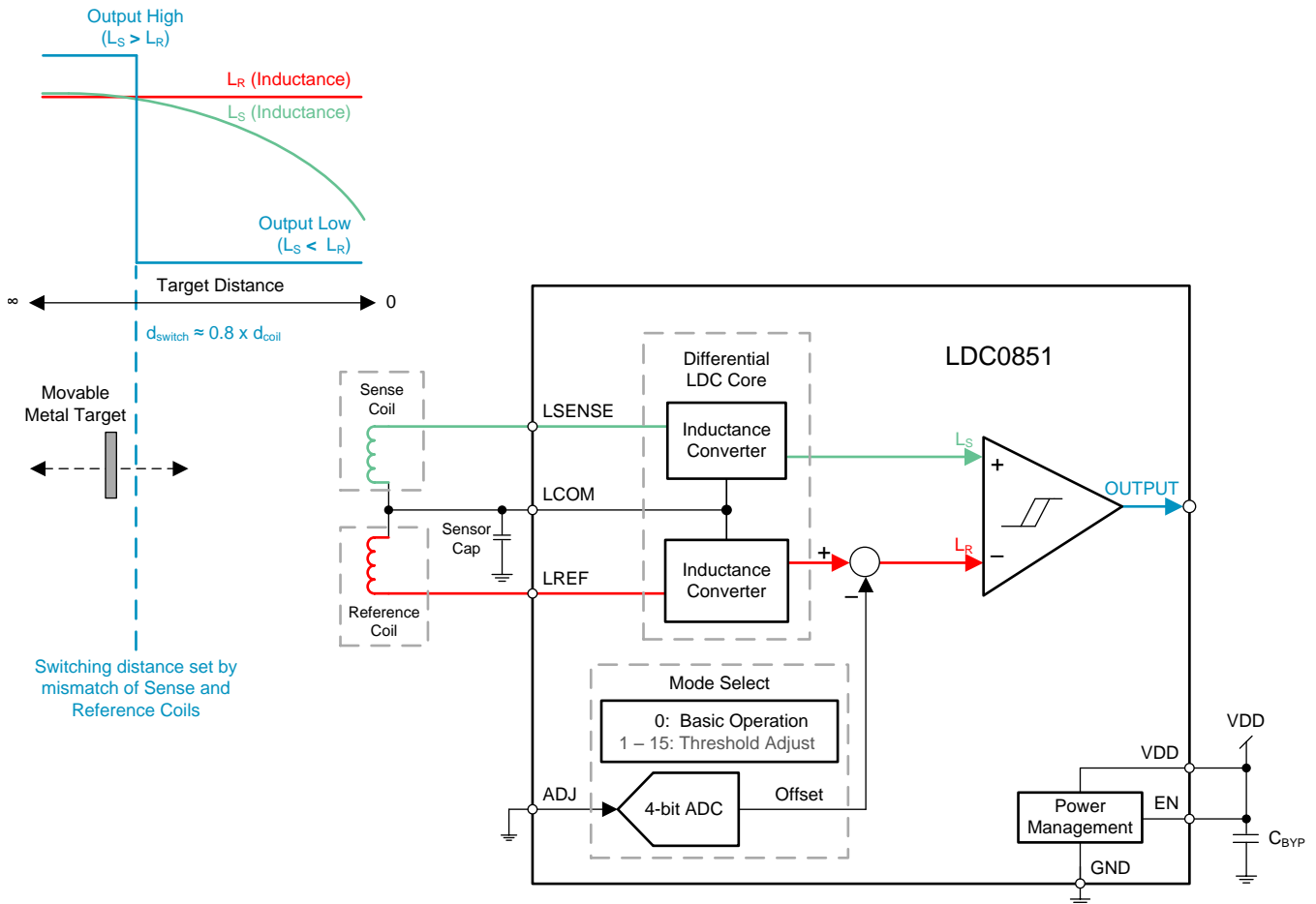

Figure 18. Basic Operation Mode Diagram for Distance Sensing With Mismatched Coils

## Feature Description (continued)

### 8.3.2 Threshold Adjust Mode

In Threshold Adjust mode, an offset inductance is subtracted from LREF to alter the switching threshold without the use of a reference target. In order to configure the LDC0851 for Threshold Adjust mode, place a resistor divider between VDD and GND as shown in [Figure 19](#). The threshold adjust values can then be easily changed as described in section [Setting the Threshold Adjust Values](#). Threshold adjust mode can be used in a variety of applications including coarse proximity sensing and simple button applications as shown in [Coarse Position Sensing](#). Two example coil configurations for proximity sensing are shown below for side by side coil orientation in [Figure 19](#) as well as stacked configuration in [Figure 20](#).

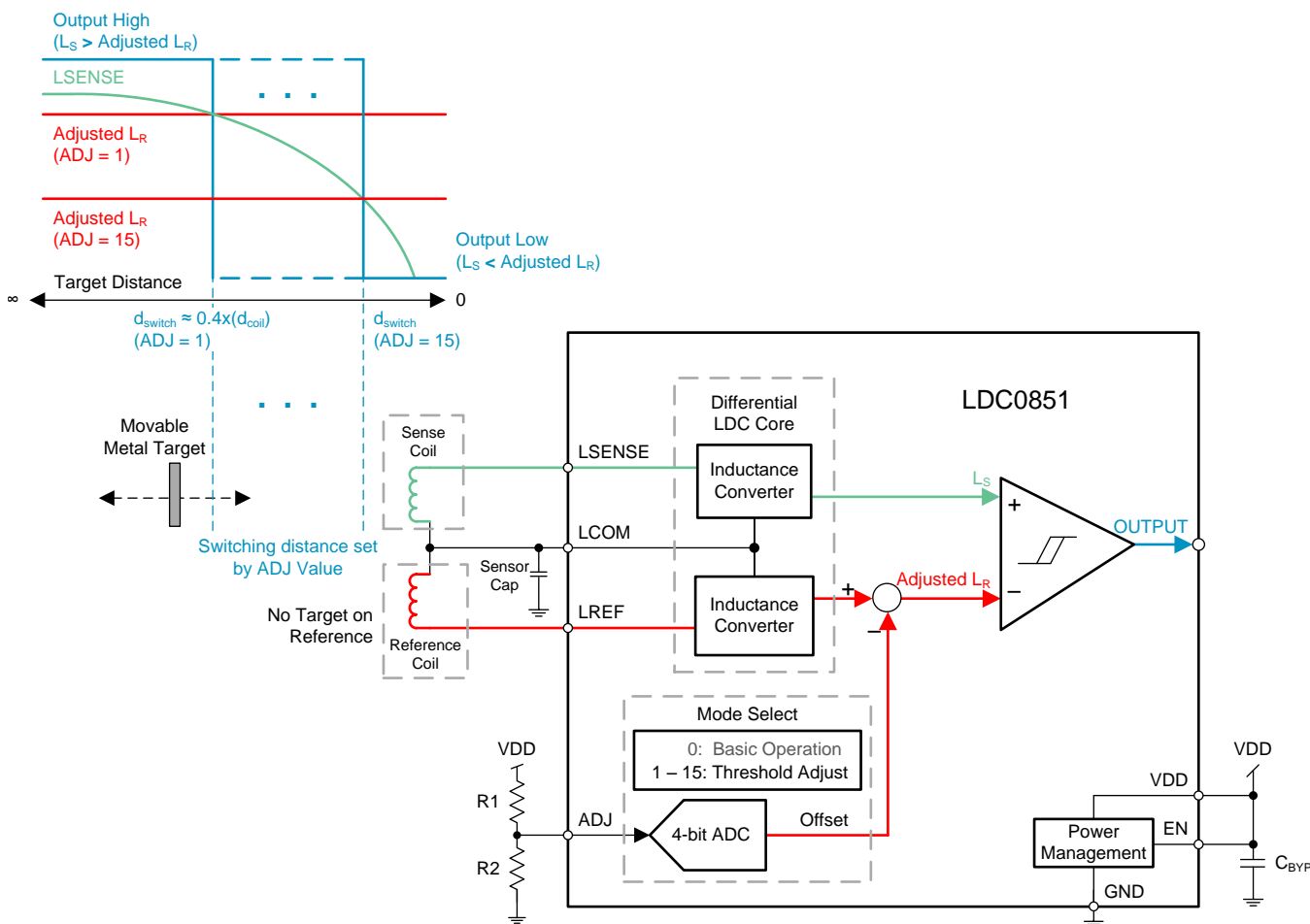

Figure 19. Threshold Adjust Mode for Distance Sensing Using Side by Side Coils

Feature Description (continued)

Stacked coils can be utilized in designs where PCB space is a concern or if the user only wants to detect proximity to metal from one side of the PCB such as a button application. The sensing range is slightly reduced due to the fact that both the sense and the reference coil are affected by same conductive target, however since the sense coil is closer to the target its respective inductance decreases more than the reference inductance allowing the output to switch as shown in Figure 20.

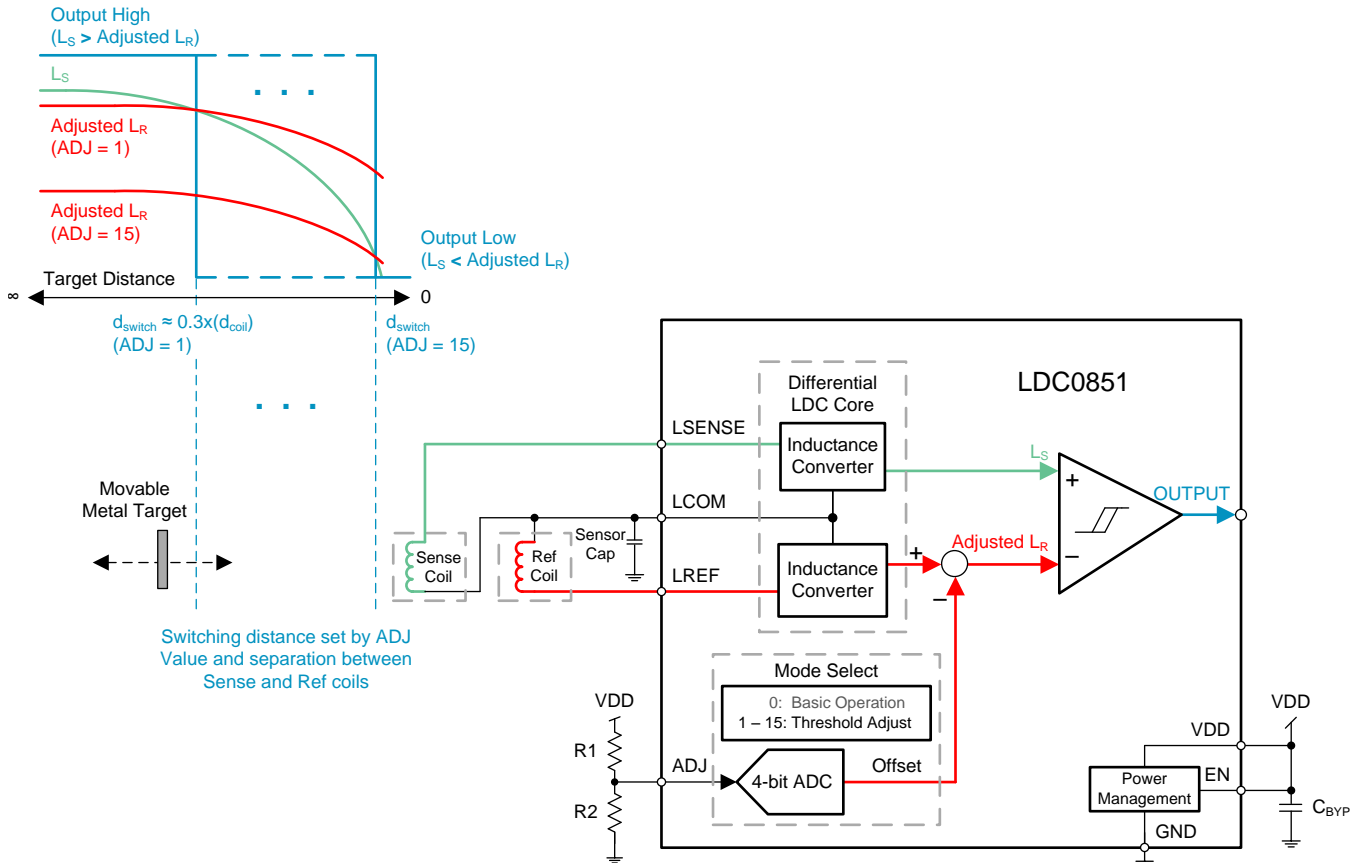

Figure 20. Threshold Adjust Mode for Distance Sensing Using Stacked Coils

To get the most sensing range with stacked coils the spacing between the sensing coil and reference coil (height = h) should be maximized as shown in Figure 21. See section Stacked Coils for more information on the layout of stacked coils.

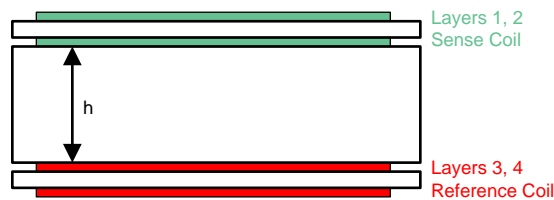

Figure 21. Stacked Coil Separation (PCB Side View)

## Feature Description (continued)

### 8.3.3 Setting the Threshold Adjust Values

To configure a threshold setting, connect a 49.9 kΩ resistor (R1) between VDD and the ADJ pin as shown in [Figure 20](#). The threshold is determined by the value of R2 as shown in the [Table 1](#) below. R1 and R2 should be 1% or tighter tolerance resistors with a temperature coefficient of <50 ppm/°C.

**Table 1. Resistor Values for ADJ Code**

ADJ Code	R2 (kΩ)
1	3.32
2	5.11
3	7.15
4	9.31
5	11.5
6	14
7	16.5
8	19.6
9	22.6
10	26.1
11	30.1
12	34
13	39
14	44.2
15	49.9

The switching distance for each ADJ code can be approximated with the following formula:

$$d_{\text{switch}} = d_{\text{coil}} \times 0.4 \times \left( 1 - \frac{\text{ADJ}_{\text{Code}}}{16} \right)$$

where:

- $d_{\text{switch}}$  is the approximated switching distance threshold
  - $d_{\text{coil}}$  is the coil diameter, in the same units as  $d_{\text{switch}}$
  - $\text{ADJ}_{\text{Code}}$  is the desired value from [Table 1](#)
- (1)

For example, consider a coil with a diameter of 10 mm: An ADJ code of 1 will yield a switching distance of 3.75 mm and for a code of 15 a switching distance of 0.25 mm. This method helps reduce the effort needed to design the coil ratio precisely for a specific switching distance. It should be noted that the maximum sensing distance is determined almost entirely by the diameter of the coil for circular coils or by the minimum outer dimension for rectangular coils.

### 8.3.4 Hysteresis

The LDC0851 includes hysteresis for the switching threshold. The switch point is determined by the inductance ratio between LSENSE and LREF. When the ratio of LSENSE to LREF drops below 99.6%, the device switches ON (output low). When LSENSE/LREF becomes greater than 100.4% it switches OFF (output high). The hysteresis window is therefore specified 0.8% from the switch ON point.

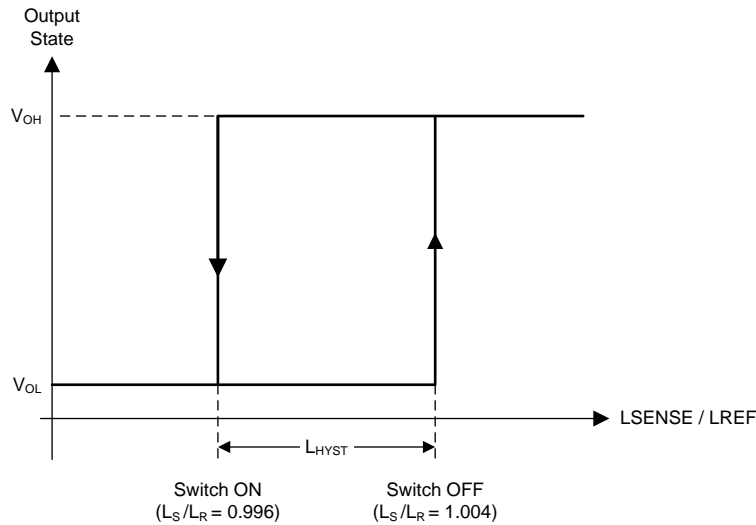

**Figure 22. Inductance Hysteresis**

For proximity sensing, hysteresis may also be approximated in terms of distance as shown in [Figure 23](#).

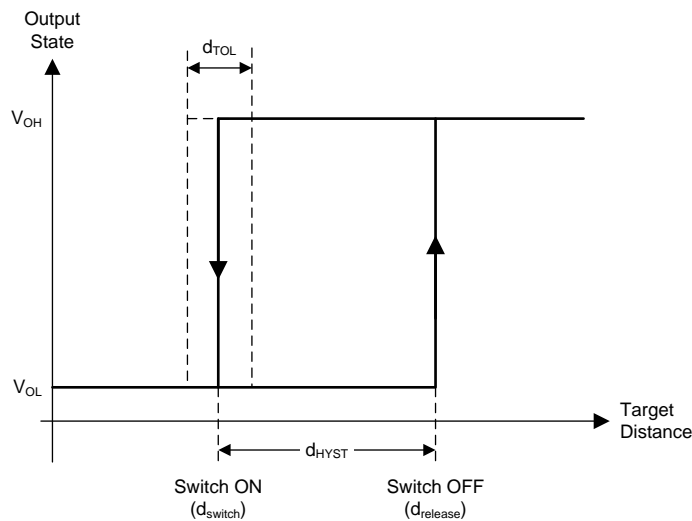

**Figure 23. Switching Distance Hysteresis and Threshold Tolerance**



### 8.3.5 Conversion Time

The length of time for the LDC0851 to complete one conversion and update the output is called the conversion time and is a function of sensor frequency. The conversion time is calculated with the following equation:

$$t_{\text{CONVERSION}} = \frac{1}{231.0 \times 10^{-6} \times f_{\text{SENSOR}}}$$

where:

- $t_{\text{CONVERSION}}$  is the conversion time interval
- $f_{\text{SENSOR}}$  is the sensor frequency given by [Equation 6](#) (2)

It is important to note that the frequency of the sensor increases in the presence of conductive objects. Therefore the worst case conversion time is calculated with no target present or when the target is at the maximum distance from the sensor.

### 8.3.6 Power-Up Conditions

This indicates the switch output state when there is no metal target within the switching distance of LDC0851. On power-up the LDC0851 output will be held HIGH until the part performs the sensor test and is ready for normal operation. This remains true even if the enable pin (EN) is pulled low. A HIGH to LOW transition on the OUT line occurs when the metal target comes within the switching distance of LDC0851. In the case of any sensor fault condition the LDC0851 maintains a HIGH state. An example of a sensor fault is if the sensor gets disconnected or damaged.

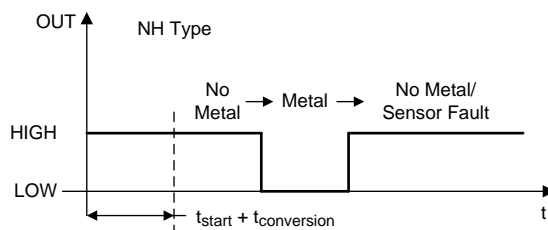

**Figure 24. Output Status at Power up and in Presence of Metal Target**

## 8.4 Device Functional Modes

### 8.4.1 Shutdown Mode

To save power, the LDC0851 has a shutdown mode. In order to place the LDC0851 in shutdown mode set the EN (Enable) pin low. This mode is useful for low power applications where the EN pin can be duty cycled at a low rate for wake-up applications to achieve a very low average supply current. An example of a duty-cycled application can be found in the applications section [Low Power Operation](#). To resume active operation, set EN high and wait  $t_{AMT} + t_{DELAY}$  for valid output data. The current consumption in this mode is given in the electrical table as  $I_{SD}$ . Note that the output will remain high (OFF) when EN is low. See [Power-Up Conditions](#) for more information on the startup conditions.

### 8.4.2 Active Mode

When the LDC0851 EN pin is pulled high, the LDC0851 is put into active mode. The active supply current ( $I_{DD}$ ) is broken up into three pieces: Static current ( $I_{static}$ ), Dynamic current ( $I_{dyn}$ ), and Sensor current ( $I_{sensor}$ ).

Static current is the DC device current given in the electrical characteristics and does not vary over frequency.

Dynamic current is the AC device current which varies with both sensor frequency ( $f_{SENSOR}$ ) and board parasitic capacitance ( $C_{BOARD}$ ). Dynamic current can be computed with the following equation:

$$I_{dyn} = (24.262 \times 10^{-12}) \times f_{SENSOR} + 1.5 \times f_{SENSOR} \times C_{BOARD}$$

where:

- $I_{dyn}$  is the dynamic current drawn by the device and board parasitics
  - $f_{SENSOR}$  is the sensor frequency calculated from [Equation 6](#)
  - $C_{BOARD}$  is the parasitic capacitance of the board, see [Figure 25](#)
- (3)

Sensor current is the AC current required to drive an external LC sensor. Sensor current varies with both the frequency and inductance of the sensor and is given by the following equation:

$$I_{sensor} = \frac{1}{17.1 \times L_{SENSOR} \times f_{SENSOR}}$$

where:

- $I_{SENSOR}$  is current required to drive the sensor
  - $L_{SENSOR}$  is the measured inductance of the sensor
  - $f_{SENSOR}$  is the sensor frequency calculated from [Equation 6](#)
- (4)

The total active supply current is given by the following equation:

$$I_{DD} = I_{dyn} + I_{static} + I_{sensor}$$

where:

- $I_{DD}$  is the total active supply current
  - $I_{dyn}$  is the dynamic current drawn by the device as given by [Equation 3](#)
  - $I_{static}$  is the static current as given in the electrical table
  - $I_{SENSOR}$  is current required to drive the sensor as given by [Equation 4](#)
- (5)

## 9 Application and Implementation

### NOTE

Information in the following applications sections is not part of the TI component specification, and TI does not warrant its accuracy or completeness. TI's customers are responsible for determining suitability of components for their purposes. Customers should validate and test their design implementation to confirm system functionality.

### 9.1 Application Information

#### 9.1.1 Sensor Design

The LDC0851 relies on two externally placed sensors ( $L_{\text{SENSE}}$  and  $L_{\text{REF}}$ ) and a capacitor ( $C_{\text{SENSOR}}$ ) for proper operation. The design and matching of the coils is very critical to ensure a proper switching occurrence. It is also important to note that the parasitic capacitance of the board ( $C_{\text{BOARD}}$ ) and of the LCOM input pin ( $C_{\text{IN\_COM}}$ ) are in parallel with  $C_{\text{SENSOR}}$ , and the sum of all three capacitances create a total capacitance ( $C_{\text{TOTAL}}$ ) which is considered part of the system.  $C_{\text{TOTAL}}$  must be greater than 33 pF to be considered in the valid design space.

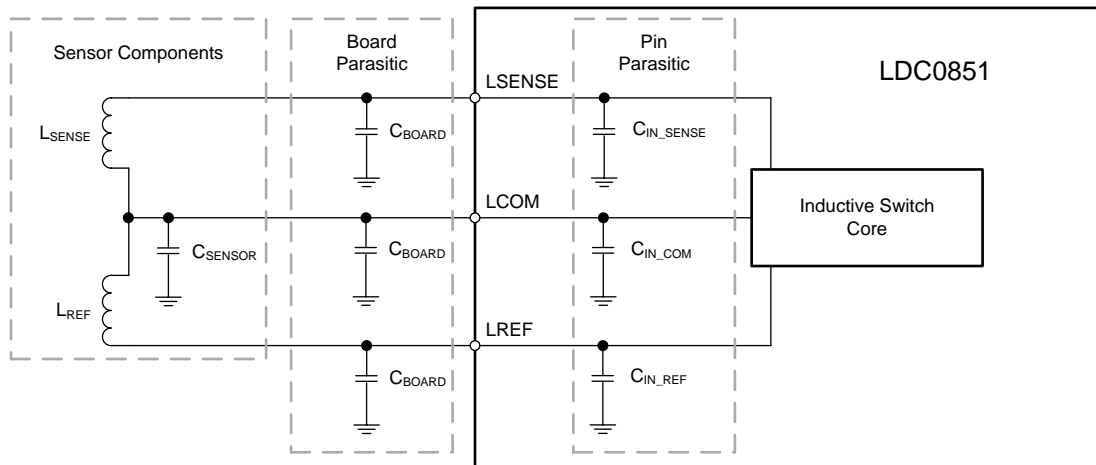

Figure 25. Sensor Components, Board Parasitics, and Package Parasitics Diagram

##### 9.1.1.1 Sensor Frequency

The sensor frequency is calculated with the following equation.

$$f_{\text{SENSOR}} = \frac{\sqrt{2}}{2\pi \times \sqrt{L_{\text{SENSOR}} \times C_{\text{TOTAL}}}}$$

where:

- $f_{\text{SENSOR}}$  is the calculated oscillation frequency with no target present
- $L_{\text{SENSOR}}$  is the inductance of the sense coil or reference coil
- $C_{\text{TOTAL}}$  is sum of external sensor, board parasitic, and pin parasitic capacitances connected to LCOM, refer to [Figure 25](#) (6)

## Application Information (continued)

### 9.1.1.2 Sensor Design Procedure

The following procedure should be followed for determining the sensor characteristics:

1. Determine the diameter of coil ( $d_{\text{coil}}$ ), which should be 3 times larger than the desired switching distance ( $d_{\text{switch}}$ )
2. Determine the desired frequency ( $f_{\text{SENSOR}}$ ) which should be between 300 kHz and 19 MHz
3. Calculate the range of allowable inductance from the following equation:

$$L_{\text{SENSOR}} \geq \frac{1}{4.83 \times (f_{\text{SENSOR}}) \times (I_{\text{SENSOR\_MAX}})}$$

where:

- $L_{\text{SENSOR}}$  is the inductance of the LSENSE coil or LREF coil
- $I_{\text{SENSOR\_MAX}}$  is given in the electrical table

(7)

4. Calculate the externally placed sensor capacitor:

$$C_{\text{SENSOR}} = \frac{1}{(\pi \times f_{\text{SENSOR}})^2 (2 \times L_{\text{SENSOR}})} - C_{\text{BOARD}} - C_{\text{IN\_COM}}$$

where:

- $C_{\text{BOARD}}$  is the parasitic capacitance introduced by the board layout (~4 pF for good layout)
- $C_{\text{IN\_COM}}$  is the parasitic pin capacitance of LCOM specified as 12 pF in the electrical table

(8)

## 9.2 Typical Application

### 9.2.1 Event Counting

The LDC0851 can be used for event counting applications such as gear tooth detection or rotational speed measurements. An example of gear tooth detection using side by side coils is shown below where the gear is made of a conductive material and rotates over the coils. Two identical coils can be placed such that when one of the coils is covered by a gear tooth, the other is uncovered. The output will toggle when the inductance values of both coils are equal as the gear passes by.

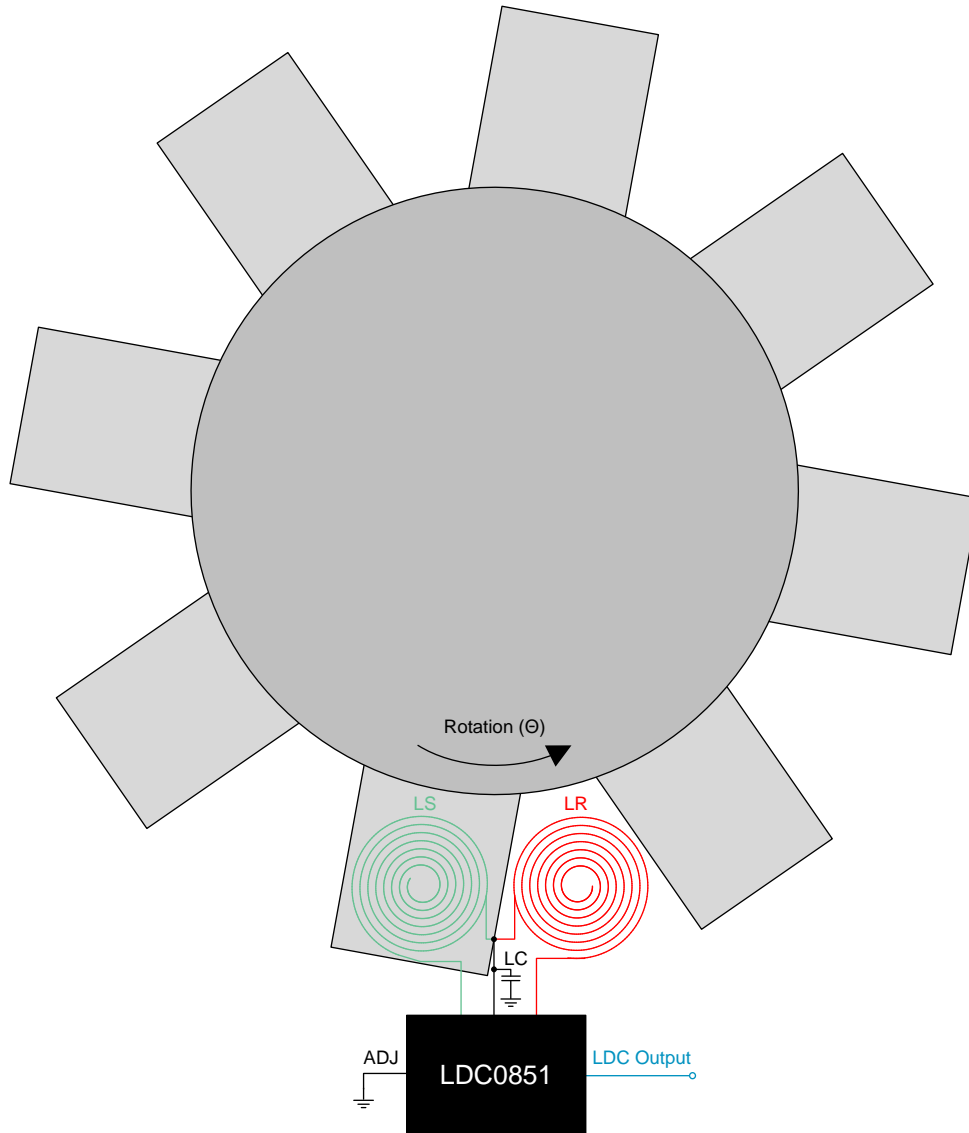

**Figure 26. Gear Tooth Functional Diagram**

#### 9.2.1.1 Design Requirements

Assume a gear with 8 conductive teeth is used in a system to determine flow rate. Determine the maximum speed that can be reliably detected by the LDC0851 using a sensor frequency of 15 MHz.

## Typical Application (continued)

### 9.2.1.2 Detailed Design Procedure

To ensure a reliable reading an event must be sampled twice when the gear tooth covers more of the LSENSE coil than the LREF coil ( $L_S < L_R$ ) producing a LOW output and equivalently twice when the gear tooth covers more of LREF than LSENSE ( $L_R < L_S$ ) producing a HIGH output. The maximum speed can be achieved when the output toggles at a duty cycle rate of 50%. This can be achieved by using a gear where the width of each tooth is the same as the width of the gaps between the teeth. For asymmetric systems, the minimum width of either the gap or the gear tooth determines the maximum detectable speed. For symmetrical systems, the maximum rotational speed that can be reliably detected in revolutions per minute (rpm) for a given number of gear teeth can be determined by the following formula:

$$\text{Gear Speed (rpm)} = \frac{1}{4} \times \left[ f_{\text{SENSOR}} \times (231.0 \times 10^{-6}) \right] \times \left( \frac{60}{\# \text{ gear teeth}} \right)$$

where:

- Gear Speed (rpm) is the calculated speed of the gear
- $f_{\text{SENSOR}}$  is the sensor frequency given by [Equation 6](#)
- # gear teeth is the total number of events per rotation (9)

A gear with 8 teeth and sensor frequency of 15MHz could reliably measure a gear rotational speed of 6500 rpm.

### 9.2.1.3 Application Curves

The metal coverage has an inverse relationship to coil inductance. [Figure 27](#) shows the relationship between the output of the LDC0851 and relative inductance of the coils as the gear is rotating.

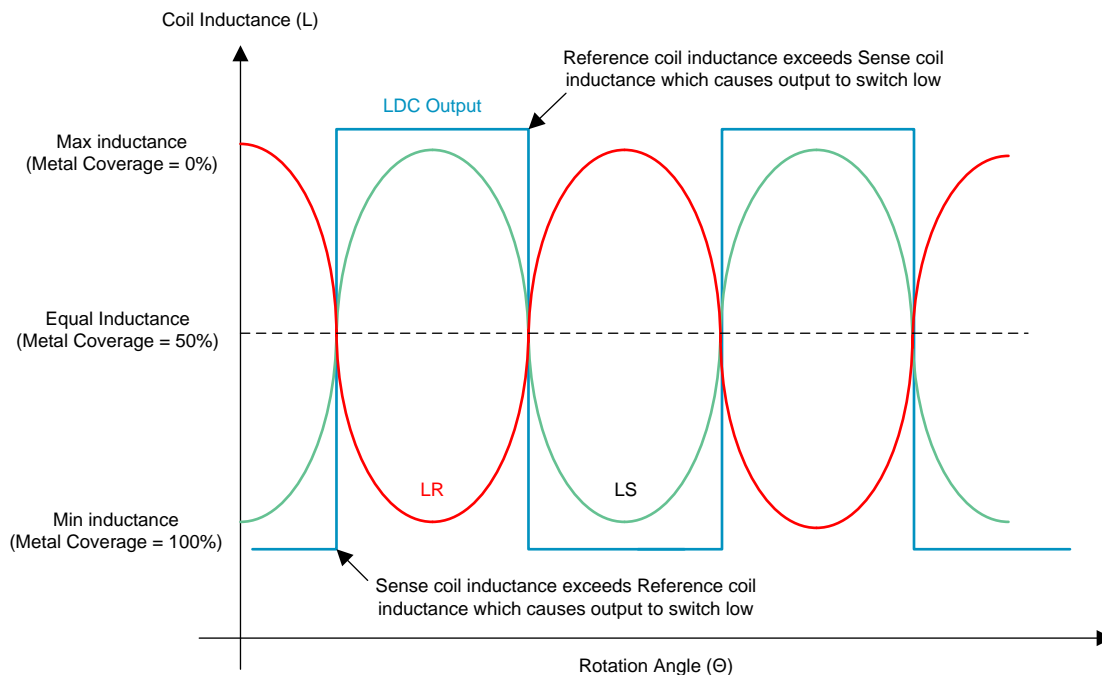
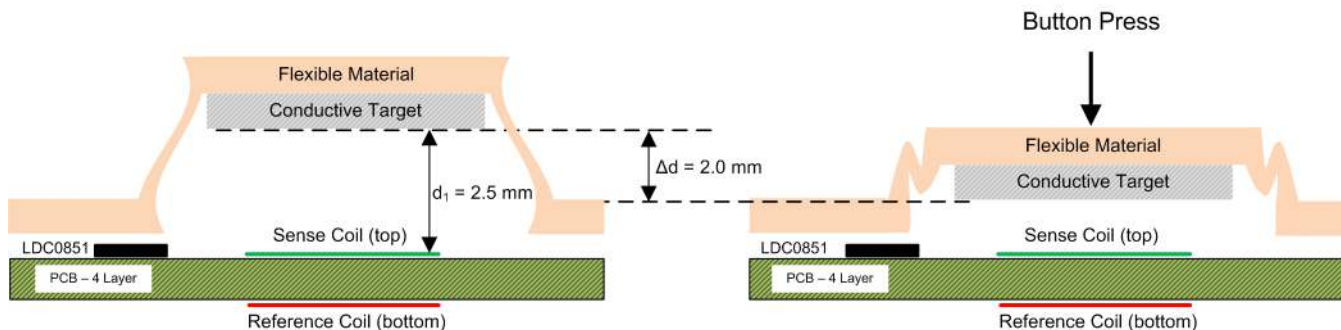

**Figure 27. Angular Position vs Coil Inductance**

## Typical Application (continued)

### 9.2.2 Coarse Position Sensing

The LDC0851 may be used for coarse proximity sensing such as a push button application. A conductive target may be added to the underside of a mechanical push button as shown below.



**Figure 28. Coarse Position Sensing Side View**

#### 9.2.2.1 Design Requirements

A push button that is made of flexible material has a conductive target attached to the underside and a contactless solution using the LDC0851 is required for reliability purposes. Determine the coil characteristics as well as the threshold adjust setting if the following conditions are true:

1. The target is made of a conductive material, such as aluminum foil or copper tape
2. The conductive target is circular and measures 10 mm in diameter
3. The resting height of the conductive target is 2.5 mm above the PCB when no button push
4. The maximum travel distance when pressed is 2 mm, leaving an airgap of 0.5mm above the PCB

#### 9.2.2.2 Detailed Design Procedure

To conserve PCB area, a 4 layer stacked coil approach is used with the sense coil on the top 2 layers and reference on the bottom 2 layers. The LDC0851 switching threshold is then determined by following parameters:

1. Conductive Target Size: The best response is achieved when the target area is  $\geq 100\%$  compared to the coil area.
2. Coil diameter: The diameter of the coil should be at least 3x greater than the desired switching distance.
3. ADJ code: Increasing ADJ code linearly scales down the switching distance estimated by [Equation 1](#).

The coil diameter should not exceed the diameter of the conductive target of 10mm in order to keep the target-to-coil coverage  $\geq 100\%$ . Additionally, in order to detect the lightest button pushes where the conductive target rests at a height of 2.5 mm, the coil should be at least 3 times greater giving a minimum size of 7.5 mm. The user may therefore select a coil size between 7.5 mm and 10 mm. A coil diameter of 10mm is chosen for the most flexibility and tuning range. The response versus ADJ code is shown below in [Figure 29](#).

In this example the deflection caused by the button press ( $\Delta d$ ) is 2mm. Note that the  $\Delta d$  must be enough to cross the "Switch ON" threshold and return past "Switch OFF" threshold of the LDC0851 for a given ADJ code to be considered a valid code. Codes 0 through 6 should not be used because the conductive target has already crossed the "Switch ON" thresholds and would always be in the ON state without a button push. Similarly code 15 should not be used because the output would always be in an OFF state regardless of how hard the button is pushed. Therefore codes 8 through 14 are clearly inside the travel distance of the button. Select code 8 to detect light button pushes, code 11 for medium button pushes, or code 14 to only detect strong button pushes. Once the ADJ code is selected based on user preference, set the resistor divider R1 and R2 values according to section [Setting the Threshold Adjust Values](#).

**Typical Application (continued)**

**9.2.2.3 Application Curves**

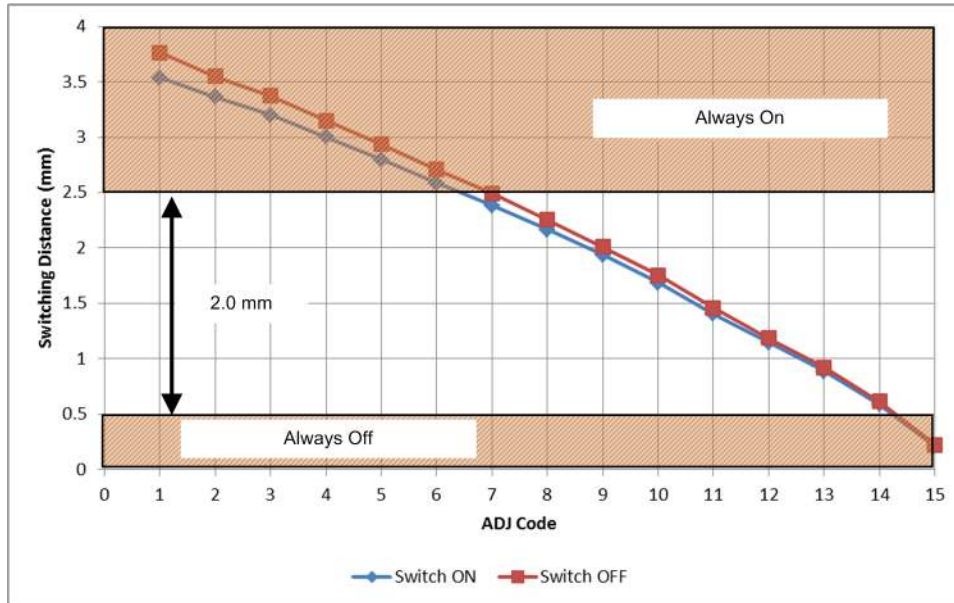

**Figure 29. Threshold Adjust Design Space for 10mm Coil Example**



## Typical Application (continued)

### 9.2.3 Low Power Operation

It may be desirable to operate the LDC0851 on battery power and take samples at a very low sample rate, such as portable sensor devices or intruder detection systems. By using a nanotimer (ultra low power timer) such as the TPL5110 or a microcontroller such as the MSP430F5500 it is possible to duty cycle the EN pin of the LDC0851 as shown in the application schematic in Figure 30.

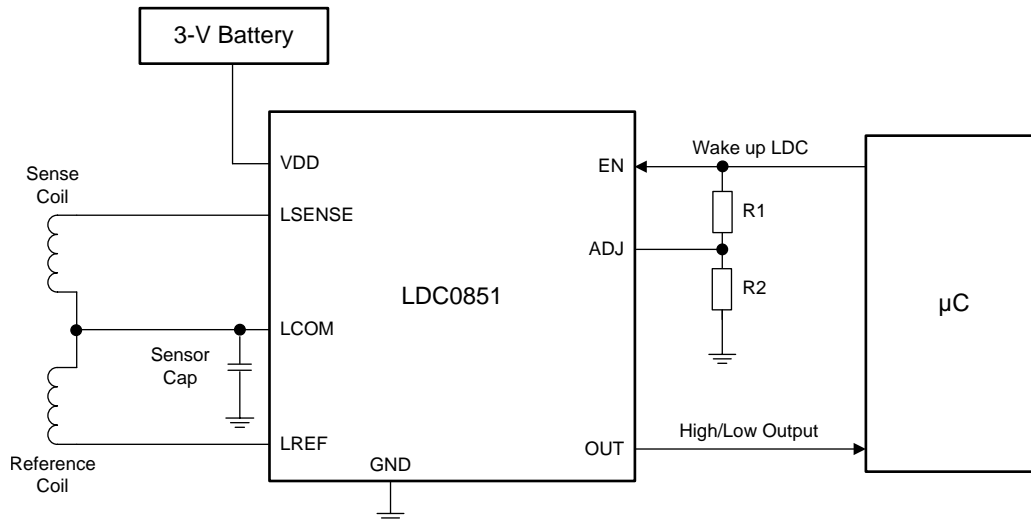

Figure 30. Application Schematic Showing Low Power Operation

#### 9.2.3.1 Design Requirements

The LDC0851 is used in a low power, battery operated system to detect when a window is opened. Determine the average supply current of the LDC0851 if following requirements exist:

1. A lifetime of greater than 10 years is required from a single CR2032 battery which supplies the power for the LDC0851.
2. A microcontroller can be used to wakeup the LDC0851 and capture the high/low output state.
3. At least 1 sample per second ( $f_{\text{SAMPLE}}$ ) is required to detect if the window is open or closed.

#### 9.2.3.2 Detailed Design Procedure

In order to achieve 10 year lifetime out of a single CR2032 battery, the enable pin (EN) of the LDC0851 can be duty cycled to achieve a low average supply current. Refer to Figure 31 to see the three different states of LDC0851 supply current during duty cycle operation. The sum of the Standby, Ramp, and On currents can be used to calculate the average supply current of the LDC0851, which needs to be below 2.5  $\mu\text{A}$  to achieve a 10 year lifetime from a 220 mAh CR2032 battery.

The average supply current can be calculated in the following steps:

1. Select desired system sample rate ( $f_{\text{SAMPLE}}$ ) based on the given application. In this example,  $f_{\text{SAMPLE}}$  is 1 sample per second.
2. Select the sensor characteristics ( $f_{\text{SENSOR}}$ ,  $L_{\text{SENSOR}}$ ,  $C_{\text{SENSOR}}$ ) based on conversion time and current consumption.
  - (a)  $f_{\text{SENSOR}}$  should be increased as much as possible to minimize the conversion time. 10 MHz is chosen as a starting point.
  - (b)  $L_{\text{SENSOR}}$  should be increased as much as possible to decrease the sensor current ( $I_{\text{SENSOR}}$ ). Based on a reasonable PCB area, 10  $\mu\text{H}$  is a good starting point.
  - (c)  $C_{\text{SENSOR}}$  is calculated to be 34.5 pF from Equation 8 using the inputs above. This makes  $C_{\text{TOTAL}}$  equal to 50.5 pF which meets the requirement of greater than 33 pF to be inside the design space.

3. Calculate the average active current:

$$I_{\text{ON}} = f_{\text{SAMPLE}} \times (2 \times t_{\text{CONVERSION}}) \times (I_{\text{DD}})$$

## Typical Application (continued)

where:

- $f_{\text{SAMPLE}}$  is the number of samples per second given from step 1. In this example,  $f_{\text{SAMPLE}}$  is equal to 1.
- $t_{\text{CONVERSION}}$  is calculated from Equation 2 to give a conversion time of 433  $\mu\text{s}$ .
- $I_{\text{DD}}$  is the total active supply current given by Equation 5 to be 1.587 mA.
- $I_{\text{ON}}$  is the active current consumed by the LDC0851 which comes to be 1.37  $\mu\text{A}$ . (10)

4. Calculate the average ramp current:

$$I_{\text{RAMP}} = f_{\text{SAMPLE}} \times (t_{\text{AMT}}) \times \left( \frac{I_{\text{DD}}}{2} \right)$$

where:

- $f_{\text{SAMPLE}}$  is the number of samples per second given from step 1. In this example,  $f_{\text{SAMPLE}}$  is equal to 1.
- $t_{\text{AMT}}$  is the active mode transition time given in the electrical table as typically 450  $\mu\text{s}$ .
- $I_{\text{DD}}$  is the total active supply current given by Equation 5 to be 1.587 mA.
- $I_{\text{RAMP}}$  is the current consumed by the LDC0851 before a conversion has started which comes to be 0.357  $\mu\text{A}$ . (11)

5. Calculate the average standby current:

$$I_{\text{OFF}} = (1 - f_{\text{SAMPLE}} \times (t_{\text{AMT}} - 2 \times t_{\text{CONVERSION}})) \times (I_{\text{SD}})$$

where:

- $f_{\text{SAMPLE}}$  is the number of samples per second given from step 1. In this example,  $f_{\text{SAMPLE}}$  is equal to 1.
- $t_{\text{AMT}}$  is the active mode transition time given in the electrical table as typically 450  $\mu\text{s}$ .
- $t_{\text{CONVERSION}}$  is calculated from Equation 2 to give a conversion time of 433  $\mu\text{s}$ .
- $I_{\text{SD}}$  is the shutdown current of the LDC0851 given in the electrical table as typically 140 nA.
- $I_{\text{OFF}}$  is the standby current of the LDC0851 which comes to be 0.140  $\mu\text{A}$ . (12)

6. Calculate the total average supply current:

$$I_{\text{AVG}} = I_{\text{ON}} + I_{\text{RAMP}} + I_{\text{OFF}}$$

where:

- $I_{\text{ON}}$  is the active supply current given from Equation 10 to be 1.37  $\mu\text{A}$ .
- $I_{\text{RAMP}}$  is the ramp current given by Equation 11 to be 0.357  $\mu\text{A}$ .
- $I_{\text{OFF}}$  is the standby current given by Equation 12 to be 0.140  $\mu\text{A}$ .
- $I_{\text{AVG}}$  is the average supply current consumed per second which comes to 1.867  $\mu\text{A}$ . (13)

7. Finally the lifetime of the battery can be calculated:

$$\text{Battery Lifetime (years)} = \frac{\text{Battery Capacity}}{I_{\text{AVG}}}$$

where:

- Battery Capacity is the amount of charge x time that the battery can hold in mAh. This example uses a CR2032 battery with 220 mAh.
- $I_{\text{AVG}}$  is the value reported in Equation 13 to be 1.867  $\mu\text{A}$ .
- Battery Lifetime (years) is how long the battery will last reported in years which comes out to be 13.5 years with the inputs from above. (14)

For example, using a sensor frequency of 10 MHz, sensor inductance of 10  $\mu\text{H}$ , and 1 sample per second yields a lifetime of 13.5 years for a single CR2032 battery.

Typical Application (continued)

9.2.3.3 Application Curves

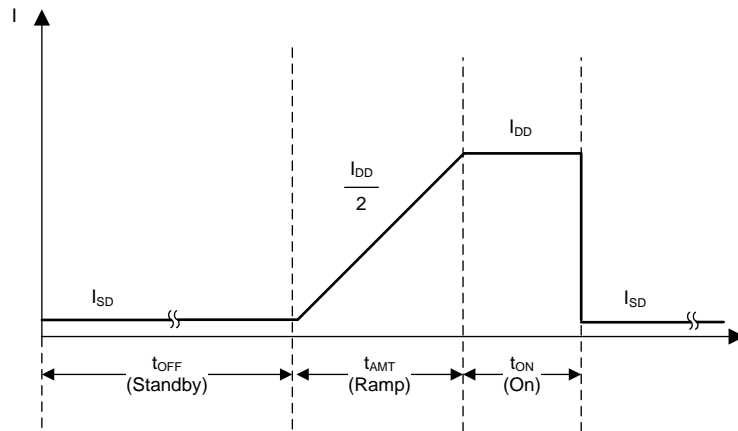
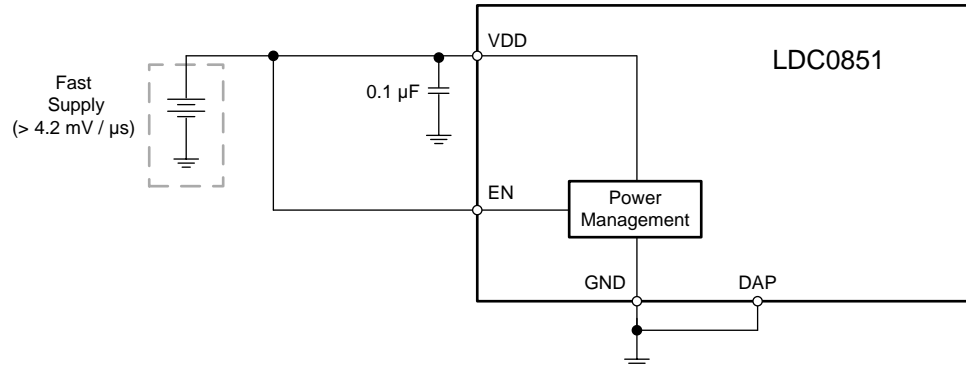

Figure 31. LDC0851 Supply Current vs. Time During Duty Cycle Operation

## 10 Power Supply Recommendations

A 0.1  $\mu\text{F}$  capacitor should be used to bypass VDD. If multiple bypass capacitors are used in the system, then the smallest value capacitor should be placed as close as possible to the VDD pin. A ground plane is recommended to connect both the ground and the Die Attach Pad (DAP). If the supply ramp rate must be faster than 4.2 mV/ $\mu\text{s}$  the enable pin (EN) may be tied directly to VDD as shown in [Figure 32](#).



**Figure 32. Supply Connections for Fast Ramp Rate**

For supply ramp rates slower than 4.2 mV/ $\mu\text{s}$ , an RC low pass filter must be added to the enable input (EN) as shown in [Figure 33](#). Alternatively, the EN pin may be tied to a nanotimer or microcontroller to wake up the LDC0851 after VDD has ramped to its nominal value.

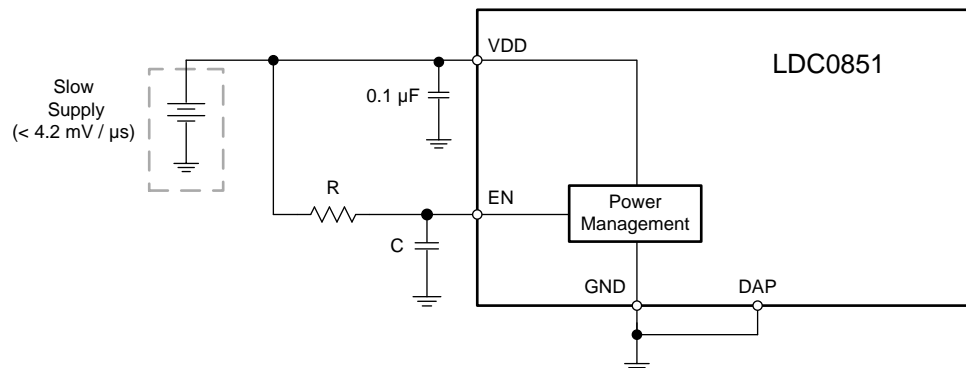

**Figure 33. Supply Connections for Slow Ramp Rate**

For applications that require low power, the EN pin may toggled with a GPIO or nanotimer to duty cycle the device and achieve ultra-low power consumption. Although the device may be power cycled to achieve a similar effect, some systems may not have a clean GPIO to supply the LDC0851 or the filtering on the supply may add a time constant delay which can make the use of the EN pin much more efficient and desirable for duty cycled applications. Refer to [Low Power Operation](#) for a detailed design example.

## 11 Layout

### 11.1 Layout Guidelines

The LDC0851 requires minimal external components for effective operation. An LDC0851 design should follow good layout techniques - providing good grounding and clean supplies are critical for optimum operation. Due to the small physical size of the LDC0851, use of surface mount 0402 or smaller components can ease routing. It is important to keep the routing symmetrical and minimize parasitic capacitances for LSENSE and LREF. The sensor capacitor should be placed close to the IC and keep traces far apart to minimize the effects of parasitic capacitance. For optimum performance, it is recommended to use a C0G/NP0 for the sensor capacitor.

### 11.2 Layout Example

#### 11.2.1 Side by Side Coils

The use of side by side coils is recommended for many applications that require a 2 layer PCB or that require very accurate temperature compensation. For side by side coils it is recommended to put them on the same PCB, even if using a remote sensing application. This will keep the tolerances and mismatch between the coils as small as possible. An example layout of side by side coils is shown in [Figure 34](#).

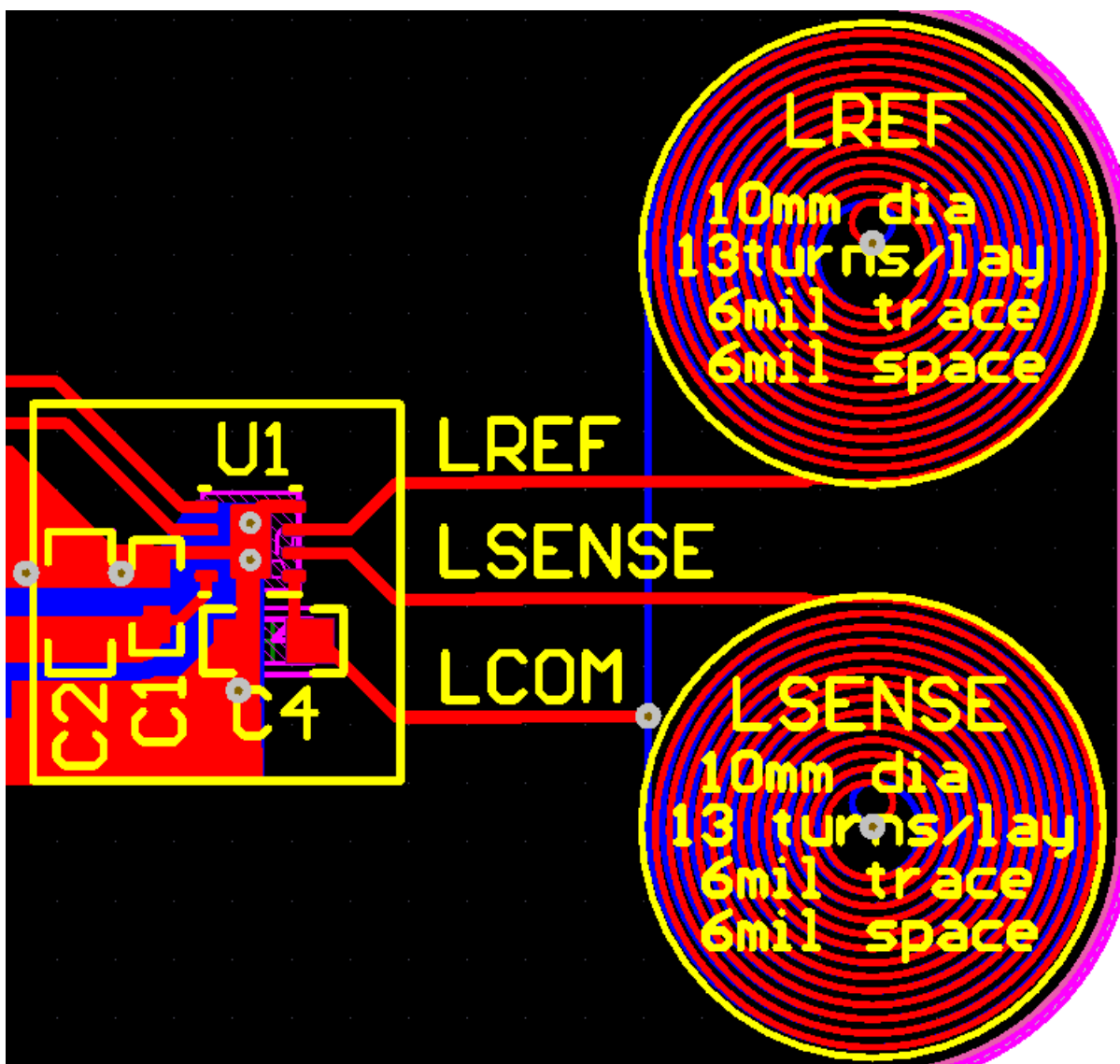
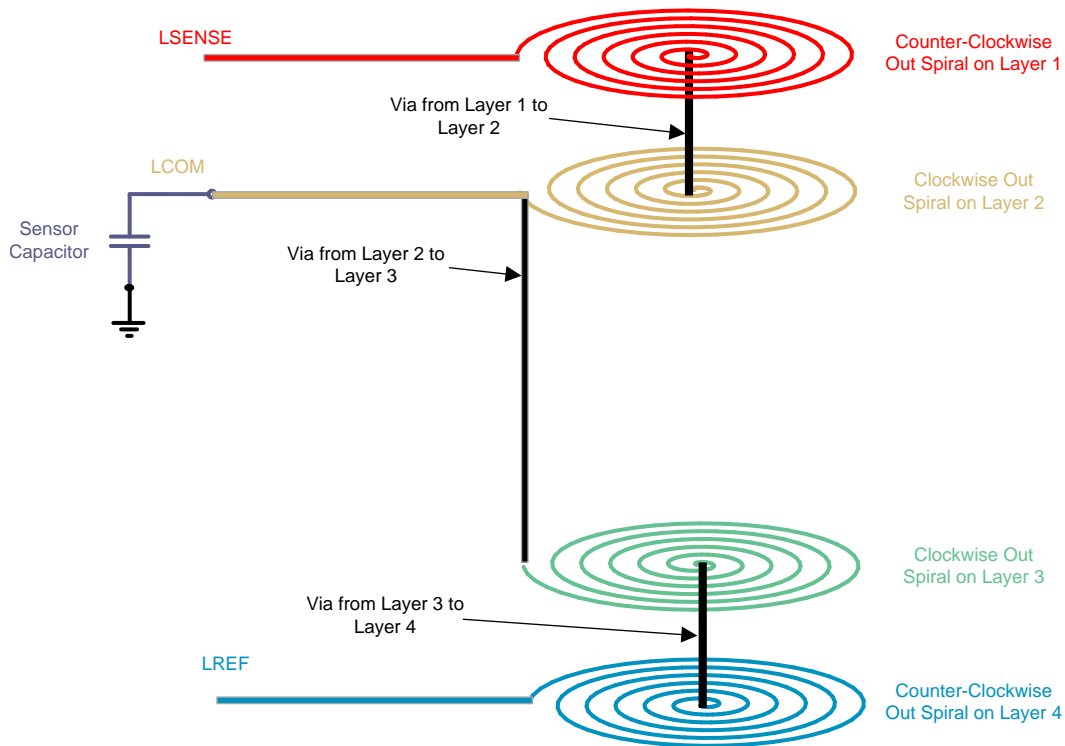

Figure 34. Side by Side Coil Layout Example

## Layout Example (continued)

### 11.2.2 Stacked Coils

Use of stacked coils may be desirable to conserve board space and to prevent false triggering when a target approaches from the bottom. A 4 layer PCB with a thick inner layer is recommended to achieve the best results. It is important to note the direction and polarity of the sense coil and reference coils with respect to each other. The recommended configuration is shown below.



**Figure 35. Stacked Coil Recommended Connections and Direction**

## 12 Device and Documentation Support

### 12.1 Device Support

#### 12.1.1 Development Support

For on-line LDC system design tools, see [Texas Instruments' Webench® tool](#)

The [LDC Calculator tools](#) provides a collection of calculation tools which run under MS Excel® useful for LDC system development.

### 12.2 Community Resources

The following links connect to TI community resources. Linked contents are provided "AS IS" by the respective contributors. They do not constitute TI specifications and do not necessarily reflect TI's views; see TI's [Terms of Use](#).

**TI E2E™ Online Community** *TI's Engineer-to-Engineer (E2E) Community*. Created to foster collaboration among engineers. At [e2e.ti.com](#), you can ask questions, share knowledge, explore ideas and help solve problems with fellow engineers.

**Design Support** *TI's Design Support* Quickly find helpful E2E forums along with design support tools and contact information for technical support.

### 12.3 Trademarks

E2E is a trademark of Texas Instruments.

Webench is a registered trademark of Texas Instruments.

Excel is a registered trademark of Microsoft Corporation.

### 12.4 Electrostatic Discharge Caution



These devices have limited built-in ESD protection. The leads should be shorted together or the device placed in conductive foam during storage or handling to prevent electrostatic damage to the MOS gates.

### 12.5 Glossary

[SLYZ022](#) — *TI Glossary*.

This glossary lists and explains terms, acronyms, and definitions.

## 13 Mechanical, Packaging, and Orderable Information

The following pages include mechanical, packaging, and orderable information. This information is the most current data available for the designated devices. This data is subject to change without notice and revision of this document. For browser-based versions of this data sheet, refer to the left-hand navigation.

**PACKAGING INFORMATION**

Orderable Device	Status (1)	Package Type	Package Drawing	Pins	Package Qty	Eco Plan (2)	Lead finish/ Ball material (6)	MSL Peak Temp (3)	Op Temp (°C)	Device Marking (4/5)	Samples
LDC0851HDSGR	ACTIVE	WSON	DSG	8	3000	RoHS & Green	NIPDAU	Level-1-260C-UNLIM	-40 to 125	0851	<a href="#">Samples</a>
LDC0851HDSGT	ACTIVE	WSON	DSG	8	250	RoHS & Green	NIPDAU	Level-1-260C-UNLIM	-40 to 125	0851	<a href="#">Samples</a>

(1) The marketing status values are defined as follows:

**ACTIVE:** Product device recommended for new designs.

**LIFEBUY:** TI has announced that the device will be discontinued, and a lifetime-buy period is in effect.

**NRND:** Not recommended for new designs. Device is in production to support existing customers, but TI does not recommend using this part in a new design.

**PREVIEW:** Device has been announced but is not in production. Samples may or may not be available.

**OBSOLETE:** TI has discontinued the production of the device.

(2) **RoHS:** TI defines "RoHS" to mean semiconductor products that are compliant with the current EU RoHS requirements for all 10 RoHS substances, including the requirement that RoHS substance do not exceed 0.1% by weight in homogeneous materials. Where designed to be soldered at high temperatures, "RoHS" products are suitable for use in specified lead-free processes. TI may reference these types of products as "Pb-Free".

**RoHS Exempt:** TI defines "RoHS Exempt" to mean products that contain lead but are compliant with EU RoHS pursuant to a specific EU RoHS exemption.

**Green:** TI defines "Green" to mean the content of Chlorine (Cl) and Bromine (Br) based flame retardants meet JS709B low halogen requirements of <=1000ppm threshold. Antimony trioxide based flame retardants must also meet the <=1000ppm threshold requirement.

(3) MSL, Peak Temp. - The Moisture Sensitivity Level rating according to the JEDEC industry standard classifications, and peak solder temperature.

(4) There may be additional marking, which relates to the logo, the lot trace code information, or the environmental category on the device.

(5) Multiple Device Markings will be inside parentheses. Only one Device Marking contained in parentheses and separated by a "~" will appear on a device. If a line is indented then it is a continuation of the previous line and the two combined represent the entire Device Marking for that device.

(6) Lead finish/Ball material - Orderable Devices may have multiple material finish options. Finish options are separated by a vertical ruled line. Lead finish/Ball material values may wrap to two lines if the finish value exceeds the maximum column width.

**Important Information and Disclaimer:**The information provided on this page represents TI's knowledge and belief as of the date that it is provided. TI bases its knowledge and belief on information provided by third parties, and makes no representation or warranty as to the accuracy of such information. Efforts are underway to better integrate information from third parties. TI has taken and continues to take reasonable steps to provide representative and accurate information but may not have conducted destructive testing or chemical analysis on incoming materials and chemicals. TI and TI suppliers consider certain information to be proprietary, and thus CAS numbers and other limited information may not be available for release.

In no event shall TI's liability arising out of such information exceed the total purchase price of the TI part(s) at issue in this document sold by TI to Customer on an annual basis.





**TAPE AND REEL INFORMATION**

**QUADRANT ASSIGNMENTS FOR PIN 1 ORIENTATION IN TAPE**

\*All dimensions are nominal

Device	Package Type	Package Drawing	Pins	SPQ	Reel Diameter (mm)	Reel Width W1 (mm)	A0 (mm)	B0 (mm)	K0 (mm)	P1 (mm)	W (mm)	Pin1 Quadrant
LDC0851HDSGR	WSON	DSG	8	3000	180.0	8.4	2.3	2.3	1.15	4.0	8.0	Q2
LDC0851HDSGT	WSON	DSG	8	250	180.0	8.4	2.3	2.3	1.15	4.0	8.0	Q2

## TAPE AND REEL BOX DIMENSIONS



\*All dimensions are nominal

Device	Package Type	Package Drawing	Pins	SPQ	Length (mm)	Width (mm)	Height (mm)
LDC0851HDSGR	WSON	DSG	8	3000	182.0	182.0	20.0
LDC0851HDSGT	WSON	DSG	8	250	182.0	182.0	20.0

## GENERIC PACKAGE VIEW

**DSG 8**

**WSON - 0.8 mm max height**

2 x 2, 0.5 mm pitch

PLASTIC SMALL OUTLINE - NO LEAD

This image is a representation of the package family, actual package may vary.  
Refer to the product data sheet for package details.

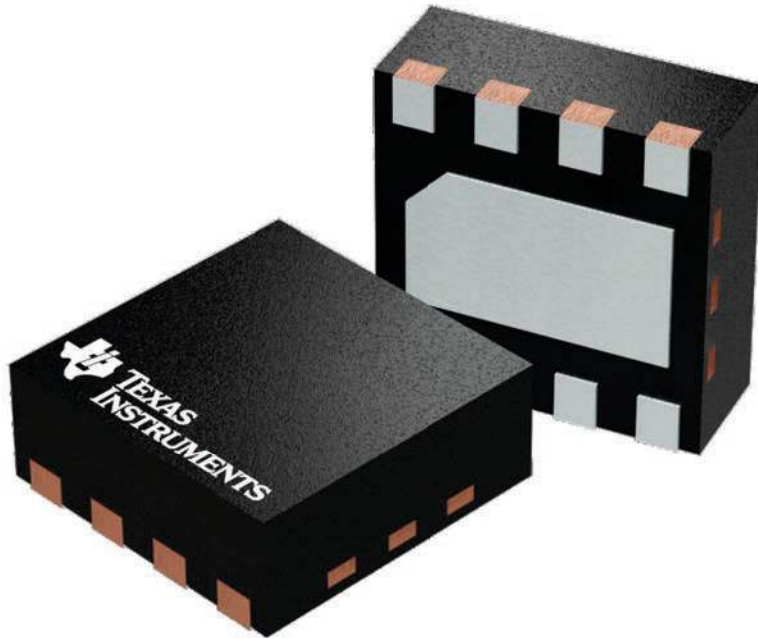

4224783/A

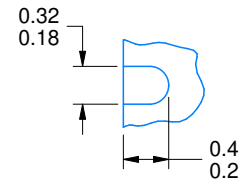
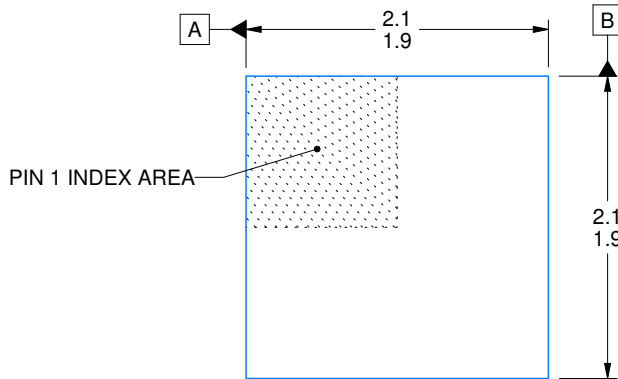

ALTERNATIVE TERMINAL SHAPE TYPICAL

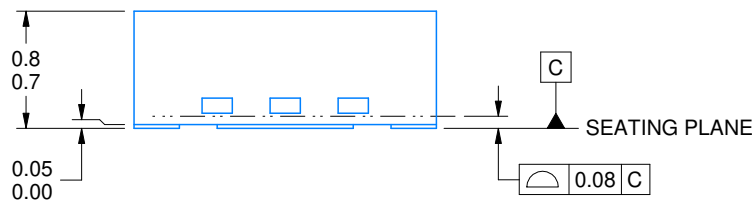

SIDE WALL METAL THICKNESS DIM A	
OPTION 1	OPTION 2
0.1	0.2

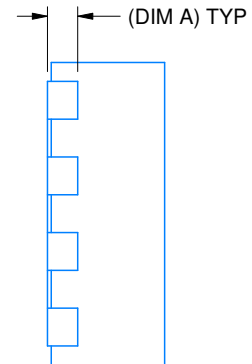
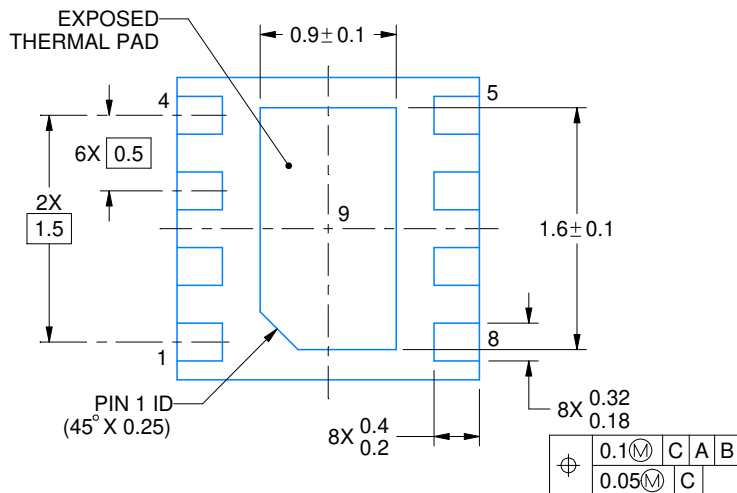

4218900/E 08/2022

NOTES:

1. All linear dimensions are in millimeters. Any dimensions in parenthesis are for reference only. Dimensioning and tolerancing per ASME Y14.5M.
2. This drawing is subject to change without notice.
3. The package thermal pad must be soldered to the printed circuit board for thermal and mechanical performance.

# EXAMPLE BOARD LAYOUT

DSG0008A

WSON - 0.8 mm max height

PLASTIC SMALL OUTLINE - NO LEAD

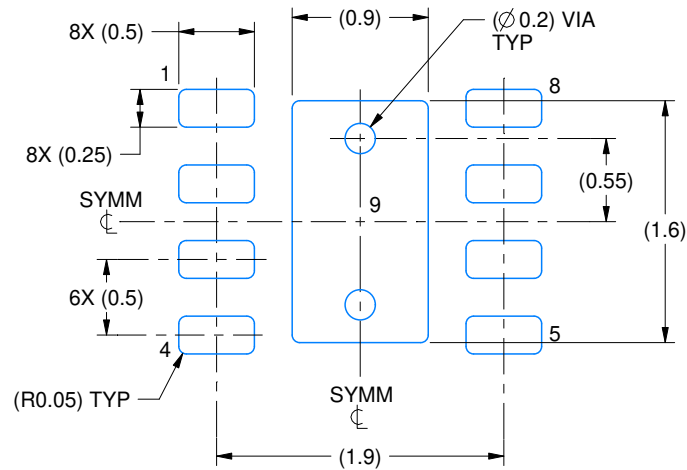

LAND PATTERN EXAMPLE  
SCALE:20X

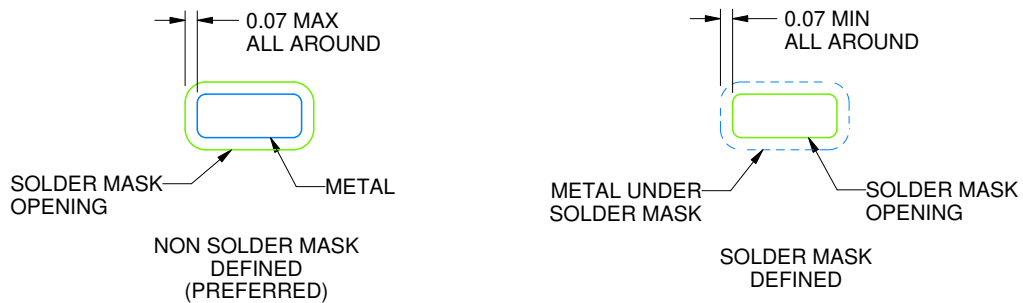

SOLDER MASK DETAILS

4218900/E 08/2022

NOTES: (continued)

4. This package is designed to be soldered to a thermal pad on the board. For more information, see Texas Instruments literature number SLUA271 ([www.ti.com/lit/slua271](http://www.ti.com/lit/slua271)).
5. Vias are optional depending on application, refer to device data sheet. If any vias are implemented, refer to their locations shown on this view. It is recommended that vias under paste be filled, plugged or tented.

# EXAMPLE STENCIL DESIGN

DSG0008A

WSON - 0.8 mm max height

PLASTIC SMALL OUTLINE - NO LEAD

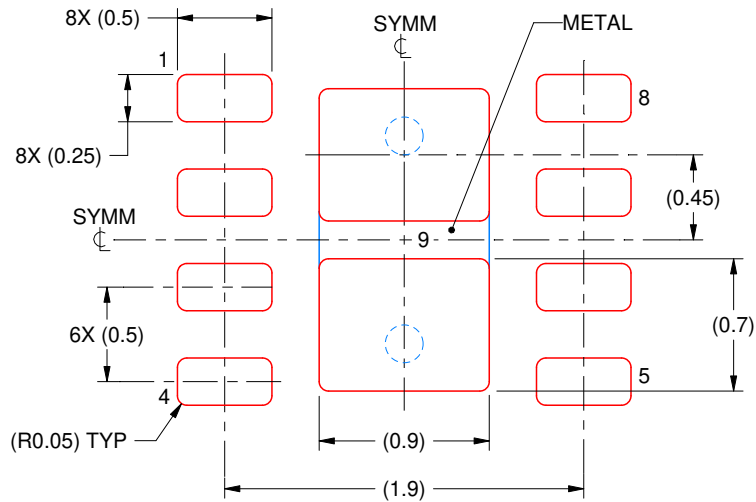

SOLDER PASTE EXAMPLE  
BASED ON 0.125 mm THICK STENCIL

EXPOSED PAD 9:  
87% PRINTED SOLDER COVERAGE BY AREA UNDER PACKAGE  
SCALE:25X

4218900/E 08/2022

NOTES: (continued)

6. Laser cutting apertures with trapezoidal walls and rounded corners may offer better paste release. IPC-7525 may have alternate design recommendations.

## IMPORTANT NOTICE AND DISCLAIMER

TI PROVIDES TECHNICAL AND RELIABILITY DATA (INCLUDING DATA SHEETS), DESIGN RESOURCES (INCLUDING REFERENCE DESIGNS), APPLICATION OR OTHER DESIGN ADVICE, WEB TOOLS, SAFETY INFORMATION, AND OTHER RESOURCES "AS IS" AND WITH ALL FAULTS, AND DISCLAIMS ALL WARRANTIES, EXPRESS AND IMPLIED, INCLUDING WITHOUT LIMITATION ANY IMPLIED WARRANTIES OF MERCHANTABILITY, FITNESS FOR A PARTICULAR PURPOSE OR NON-INFRINGEMENT OF THIRD PARTY INTELLECTUAL PROPERTY RIGHTS.

These resources are intended for skilled developers designing with TI products. You are solely responsible for (1) selecting the appropriate TI products for your application, (2) designing, validating and testing your application, and (3) ensuring your application meets applicable standards, and any other safety, security, regulatory or other requirements.

These resources are subject to change without notice. TI grants you permission to use these resources only for development of an application that uses the TI products described in the resource. Other reproduction and display of these resources is prohibited. No license is granted to any other TI intellectual property right or to any third party intellectual property right. TI disclaims responsibility for, and you will fully indemnify TI and its representatives against, any claims, damages, costs, losses, and liabilities arising out of your use of these resources.

TI's products are provided subject to [TI's Terms of Sale](#) or other applicable terms available either on [ti.com](http://ti.com) or provided in conjunction with such TI products. TI's provision of these resources does not expand or otherwise alter TI's applicable warranties or warranty disclaimers for TI products.

TI objects to and rejects any additional or different terms you may have proposed.

Mailing Address: Texas Instruments, Post Office Box 655303, Dallas, Texas 75265  
Copyright © 2022, Texas Instruments Incorporated