

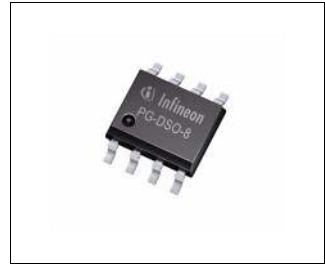

Features

- Logic level input
- Compatible to 3V micro controllers
- ESD protection
- Thermal shutdown with auto restart
- Overload protection
- Short circuit protection
- Over voltage protection
- Open load detection (during Off)
- Current limitation
- Direct parallel control of the inputs
- FREEZE functionality for multiplexing
- General fault flag
- Very low standby quiescent current
- Switching frequencies up to 50kHz
- Green Product (RoHS compliant)
- AEC Qualified



Application

- All kinds of resistive, inductive and capacitive loads in switching applications
- μ C compatible power switch for 12 V, 24 V and 42 V applications
- Replaces electromechanical relays and discrete circuits
- Line, stepper motor, lamp and relay driver

General Description

The BTS3408G is a dual channel Low-Side Switch with D-MOS output stages for driving resistive, capacitive and inductive loads. The design is based on Infineons Smart Power Technology (SPT) which allows bipolar, CMOS and power D-MOS devices on the same monolithic circuit.

The BTS3408G is protected by embedded protection functions and designed for automotive and industrial applications. It is especially suited for driving stepper motors and lines.

Type	Ordering Code	Package
HITFET® BTS3408G	on request	PG-DSO-8-36

Product Summary

Parameter	Symbol	Value	Unit
Supply voltage	V_S	4.5 - 60	V
Continuous drain source voltage	V_{DS}	60	V
On-state resistance	$R_{DS(ON)}$	550	mΩ
Current limitation	$I_{D(lim)}$	1	A
Nominal output current (individual channel)	$I_{D(Nom)}$	0.55	A
Clamping energy	E_{AS}	800	mJ

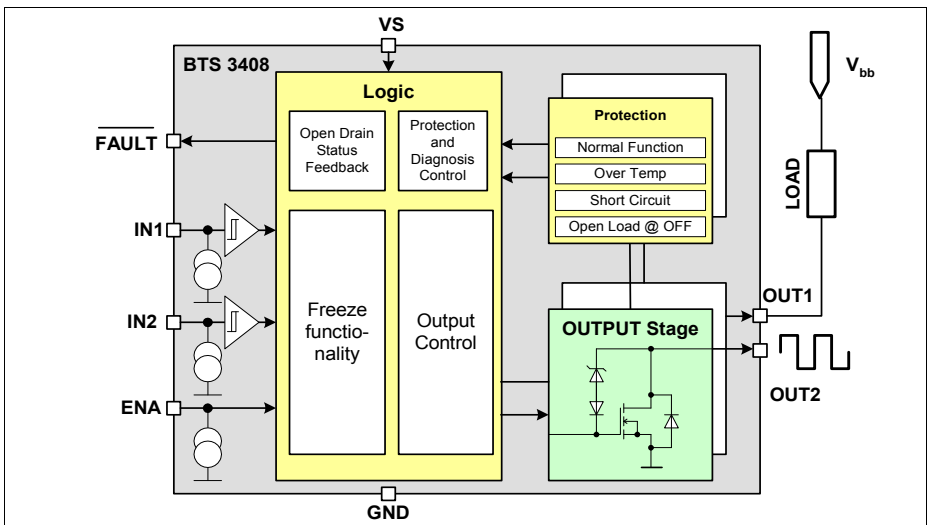
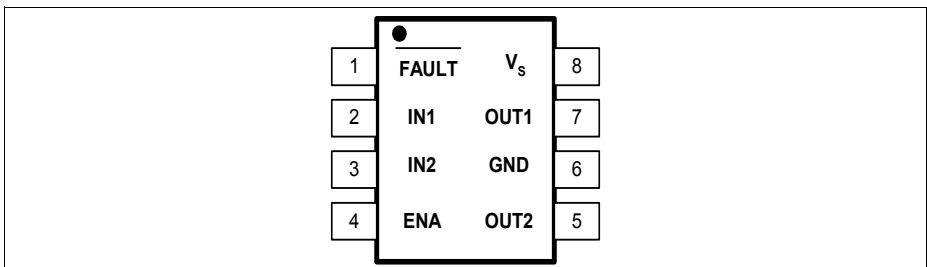
Figure 1 Block Diagram

Figure 2 Pin Configuration

Pin Definitions and Functions

Pin	Symbol	Function
1	$\overline{\text{FAULT}}$	General Fault Flag ; see Table 2 for operation mode.
2	IN1	Input 1 ; input of channel 1; has an internal pull down; TTL/CMOS compatible input.
3	IN2	Input 2 ; input of channel 2; has an internal pull down; TTL/CMOS compatible input.
4	ENA	Enable/Freeze ; has an internal pull down; device is enabled when voltage is higher then 1.2 volts; if the voltage is below 1.7 volts the output is freezed, input signals will be ignored; if the voltage is above 2 volts input signals will be output ; see Table 1 for detailed information.
5	OUT2	Output 2 ; output of D-MOS stage 2.
6	GND	Ground.
7	OUT1	Output 1 ; output of D-MOS stage 1.
8	V_S	Power supply.

Circuit Description

Logic Supply

The logic is supplied with 4.5 up to 60 volts by the V_S pin as specified in the absolute maximum ratings. The V_S functional range is specified from 4.5 up to 18 volts in the header of the electrical characteristics table. If V_S rises above 18 volts, all protections remain active, but functionalities and parameters can be deviated. If V_S falls below min. 4.5 volts, the logic is shut down and the output stages are switched off.

Direct Inputs

ENA

The ENA/FREEZE input can be used to enable and/or to freeze the output control of the IC or to cut off the complete IC.

By pulling the ENA input to low, i.e. applying a voltage V_{ENAL} , the IC is in disable mode. The power stages are switched off and the current consumption is reduced to $I_{S(stby)}$.

By applying a voltage V_{ENAFZ} , the IC is in FREEZE mode. The output signals will remain in their former state. All input signals will be ignored.

By pulling the input to high, the IC is in Enable mode. All input signals are output.

The ENA - pin has an internal pull-down.

IN1 / IN2

Each output is independently controlled via the respective input pin. The input pins are high active. If the common enable pin is high, the individual input signals are output. The input pins have an internal pull-down.

Table 1 Functional Table

V_{ENA}	Mode	IN1	IN2	IN1(-1)	IN2(-1)	OUT1	OUT2	Comment
$\leq 0.8V$	Disable	X ¹⁾	X ¹⁾	X ¹⁾	X ¹⁾	L	L	all outputs OFF
1.2 .. 1.7V	Freeze	X ¹⁾	X ¹⁾	L	L	L	L	former output state
1.2 .. 1.7V	Freeze	X ¹⁾	X ¹⁾	L	H	L	H	former output state
1.2 .. 1.7V	Freeze	X ¹⁾	X ¹⁾	H	L	H	L	former output state
1.2 .. 1.7V	Freeze	X ¹⁾	X ¹⁾	H	H	H	H	former output state
$\geq 2.0V$	Enable	L	L	X ¹⁾	X ¹⁾	L	L	input is output
$\geq 2.0V$	Enable	L	H	X ¹⁾	X ¹⁾	L	H	input is output

Table 1 Functional Table

V_{ENA}	Mode	IN1	IN2	IN1(-1)	IN2(-1)	OUT1	OUT2	Comment
$\geq 2.0V$	Enable	H	L	X ¹⁾	X ¹⁾	H	L	input is output
$\geq 2.0V$	Enable	H	H	X ¹⁾	X ¹⁾	H	H	input is output

¹⁾ X = not relevant

Power stages

Each output is protected by embedded protection functions. In the event of an overload or short to supply, the current is internally limited. The current limit is set to $I_{D(lim)}$. If this operation leads to an overtemperature condition, a second protection level (about 165 °C) will turn the effected output into a PWM-mode (selective thermal shutdown with restart) to prevent critical chip temperatures. The temperature hysteresis is typically 10K. Zener clamping is implemented to limit voltages at the power transistors when inductive loads are switched off.

Diagnostic

The general \overline{FAULT} pin is an open drain output. The \overline{FAULT} pin is low active. It signals fault conditions of any of the two output stages. By doing so, single and/or dual fault conditions can be monitored. Single fault conditions can be assigned.

Table 2 Diagnostic Table

Operating Condition	ENA	IN _x	OUT _x	\overline{FAULT}
Standby	L	X ¹⁾	OFF	H
Normal function	H	H	ON	H
Over temperature	H	H	OFF ²⁾	L
Open load / short to ground	H	L	OFF	L

¹⁾ X = not relevant

²⁾ selective thermal shutdown for each channel at overtemperature

Fault Distinction

Open load / short to ground is recognized during OFF-state. Overtemperature as a result of an overload or short to battery can only arise during ON-state. If there is only one fault at a time, it is possible to distinguish which channel is affected with which fault.

Absolute Maximum Ratings ¹⁾
 $T_j = -40^{\circ}\text{C}$ to 150°C , unless otherwise specified

Parameter	Symbol	Values	Unit	Remarks
Supply voltage	V_S	+4.5 .. +60	V	–
Drain source voltage (OUT1, OUT2)	V_{DS}	-0.3 .. +60	V	–
Input voltage (IN1, IN2, ENA)	V_{IN}	-0.3 ... +7	V	–
Continuous input current $V_{IN}>7\text{V}$	I_{IN}	1	mA	–
FAULT output voltage	V_{Fault}	-0.3 ... +7	V	–
Operating temperature range	T_j	-40 ... +150	$^{\circ}\text{C}$	–
Storage temperature range	T_{stg}	-55 ... +150	$^{\circ}\text{C}$	–
Power dissipation (DC) ²⁾	P_{tot}	0.88	W	$T_a = 25^{\circ}\text{C}$
Nominal load current ²⁾ one channel active both channel active	$I_{D(Nom)}$	0.55 0.45	A	$V_{DS}\leq 0.5\text{V}$, $T_j\leq 150^{\circ}\text{C}$, $T_A=85^{\circ}\text{C}$, $V_{IN}=5\text{V}$
Unclamped single pulse inductive energy one channel active	E_{AS}	800	mJ	$I_D=0.7\text{A}$, $T_{j(start)}=25^{\circ}\text{C}$
Electrostatic discharge voltage (Human Body Model) according to ANSI/ESDA/JEDEC JS-001 (1.5 k Ω , 100 pF)	V_{ESD}	2000	V	–

Thermal Resistance

Junction soldering point	R_{thJS}	≤ 10	K/W	–
Junction - ambient @ min. footprint	R_{thJA}	≤ 185	K/W	–
Junction - ambient @ 6cm ² cooling area ²⁾		≤ 142		

¹⁾ Not subject to production test, specified by design. Stresses above those listed here may cause permanent damage to the device. Exposure to absolute maximum rating conditions for extended periods may affect device reliability.

²⁾ Device on epoxy pcb 40 mm \times 40 mm \times 1.5 mm with 6 cm² copper area for pin 4 connection.

Electrical Characteristics
 $V_S = 4.5V$ to $18V$; $T_j = -40^\circ C$ to $150^\circ C$; unless otherwise specified

Parameter	Sym- bol	Limit Values			Unit	Test Conditions
		min.	typ.	max.		
Power supply						
Supply voltage	V_S	4.5	–	60	V	–
Supply current in enable mode	$I_{S(ON)}$	–	1.5	4	mA	ENA=High, OUT1=OUT2=On
Supply current in standby mode ¹⁾	$I_{S(stby)}$	–	–	16	μA	ENA=Low

Power outputs

Drain source clamp voltage	$V_{DS(AZ)}$	60	–	75	V	$I_D = 1$ mA
Output leakage current ²⁾	I_{DSS}	–	1	5	μA	ENA=Low, IN=Low, $V_{DS} = 60$ V
Output pull down current	$I_{PD(OL)}$	50	100	200	μA	ENA=High, IN=Low, $V_{DS} = 42$ V
On-state resistance $T_j = 25^\circ C$ $T_j = 150^\circ C$	$R_{DS(ON)}$	– –	480 800	550 1000	m Ω	$I_D = 0.2$ A, $V_S = 5$ V
Inverse diode forward voltage	$-V_{DS1}$, $-V_{DS2}$	–	0.8	1.1	V	$I_D = -0.2$ A, IN, ENA = 0V (low)
Current limit	$I_{D(lim)}$	1	1.5	2	A	–
Turn-on time IN=High to 90% I_D :	t_{on}	–	2	8	μs	$R_L = 22\Omega$, $V_{BB} = 12V$, $V_S = 5V$
Turn-off time IN=Low to 10% I_D :	t_{off}	–	2	8	μs	$R_L = 22\Omega$, $V_{BB} = 12V$, $V_S = 5V$

Digital inputs (IN1, IN2, ENA)

Input 'Low' voltage IN1, IN2: ENA:	V_{INL} V_{ENAL}	-0.3 -0.3	– –	0.8 0.8	V	–
ENA voltage for 'FREEZE' functionality	V_{ENAFZ}	1.2	–	1.7	V	–

Electrical Characteristics (cont'd)
 $V_S = 4.5V$ to $18V$; $T_j = -40^\circ C$ to $150^\circ C$; unless otherwise specified

Parameter	Sym- bol	Limit Values			Unit	Test Conditions
		min.	typ.	max.		
Input 'High' voltage IN1, IN2: ENA:	V_{INH} V_{ENAH}	2.0 2.0	– –	– –	V	–
Input voltage hysteresis	V_{INhys}	–	300	–	mV	–
Input pull down current IN1, IN2: ENA:	I_{INPD} I_{ENAPD}	20 20	50 50	100 100	μA	–

Digital Output (FAULT)

Output 'Low' voltage	V_{FLTL}	–	–	0.4	V	$I_{FLTL}=1.6mA$,
----------------------	------------	---	---	-----	---	--------------------

Diagnostic Functions

Open load / short to ground detection voltage	$V_{DS(OL)}$	$0.5 \cdot V_S$	$0.7 \cdot V_S$	$0.9 \cdot V_S$	V	–
Fault filter time for open load	$t_{filter(OL)}$	30	100	200	μs	$V_S=5V$

Protection Functions ³⁾

Thermal overload trip temperature	T_{jt}	150	165	180	$^\circ C$	–
Thermal hysteresis	ΔT_{jt}	–	10	–	K	–
Unclamped single pulse inductive energy one channel active, $T_{j(start)}=25^\circ C$ both channel active, $T_{j(start)}=25^\circ C$ one channel active, $T_{j(start)}=150^\circ C$ both channel active, $T_{j(start)}=150^\circ C$	E_{AS}			800 550 240 240	mJ	$I_D=0.7 A$

¹⁾ See also diagram 4 on [page 11](#).

²⁾ See also diagram 5 on [page 11](#).

³⁾ Integrated protection functions are designed to prevent IC destruction under fault conditions described in the data sheet. Fault conditions are considered as "outside" normal operating range. Protection functions are not designed for continuous repetitive operation. Not subject to production test, specified by design.

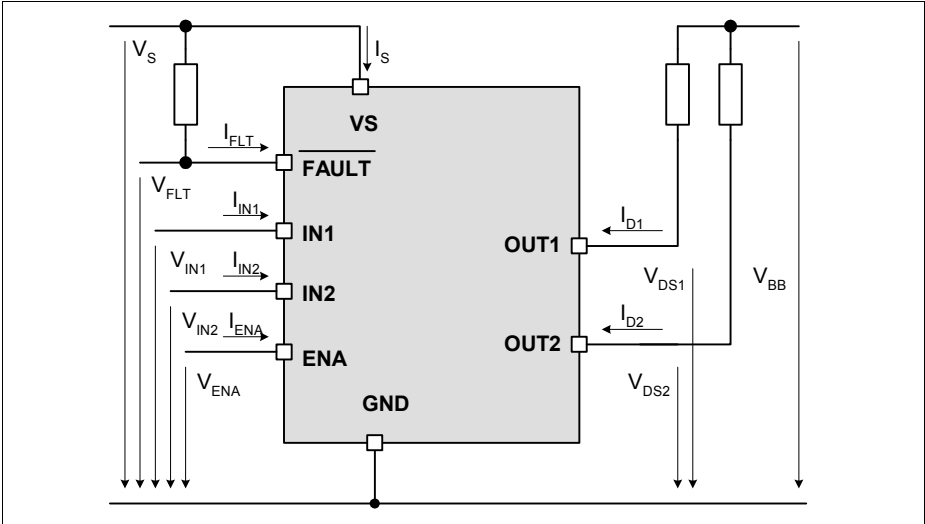
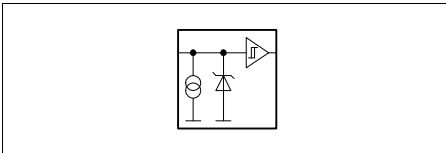
Terms

Figure 3 Input circuit (ESD protection)

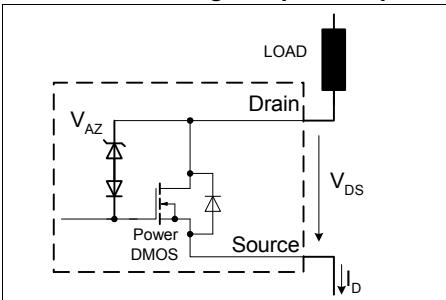
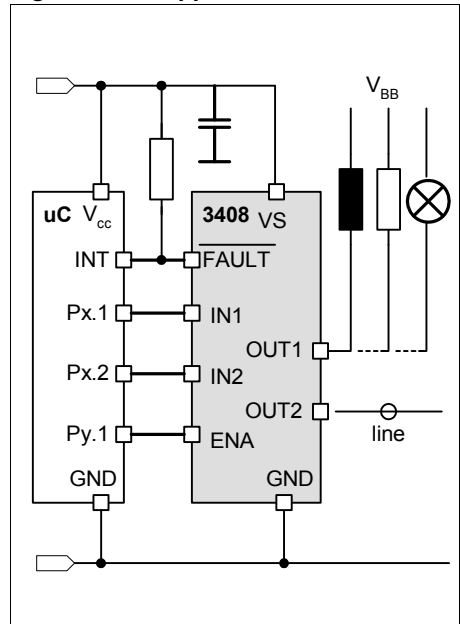
ESD zener diodes are not designed for DC current.

Figure 4 Inductive and over voltage output clamp

Figure 5 Application Circuit

Timing diagrams

Figure 6 Switching a resistive load

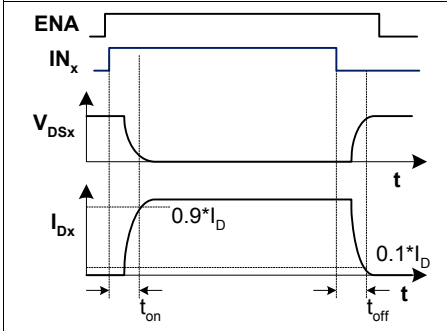

Figure 7 Switching an inductive load

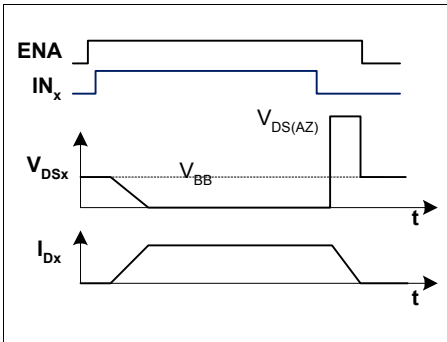
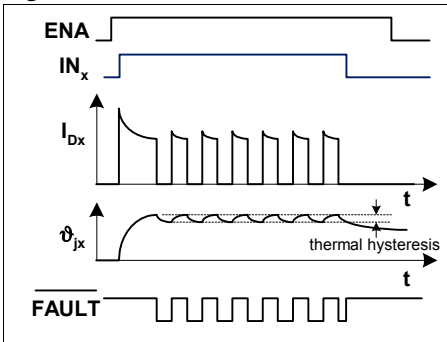

Figure 8 Short circuit



Characteristics

1. Max. allowable Power Dissipation

$$P_{\text{tot}} = f(T_{\text{amb}})$$

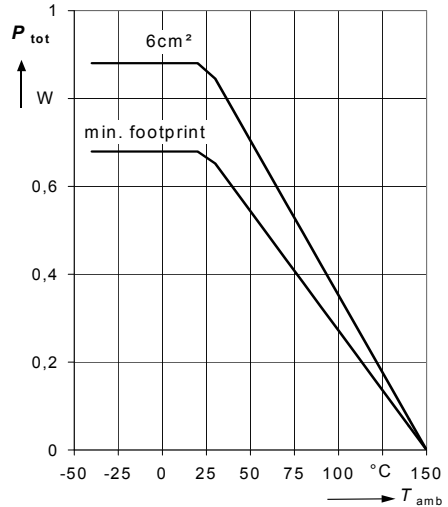

2. On-state Resistance $R_{\text{DS(ON)}} = f(T_j)$;

$$I_D = 0.2 \text{ A}; V_S = 5 \text{ V}$$

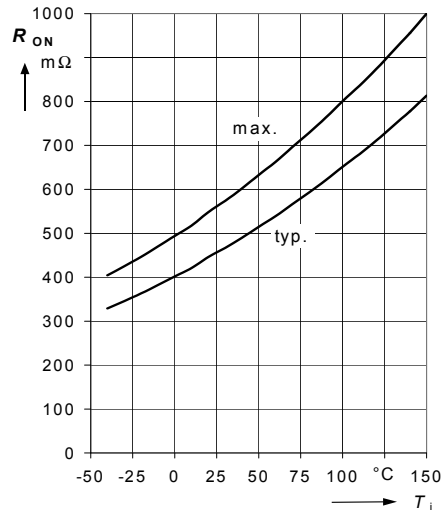

3. Typ. Short Circuit Current

$$I_{D(lim)} = f(T_j)$$

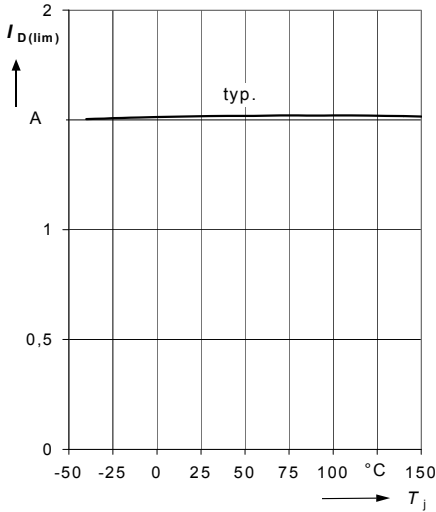
5. Typ. Output leakage current

$$I_{DSS} = f(T_j); V_S = 18 \text{ V}; V_{DS} = 60 \text{ V}$$

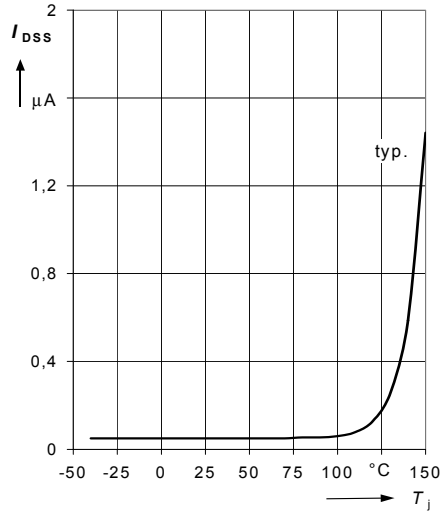
4. Typ. Supply current in Standby mode

$$I_{S(stby)} = f(T_j); V_S = 5 \text{ V}$$

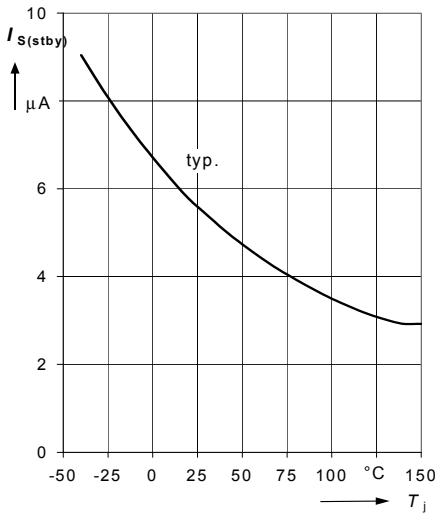

Package Outline

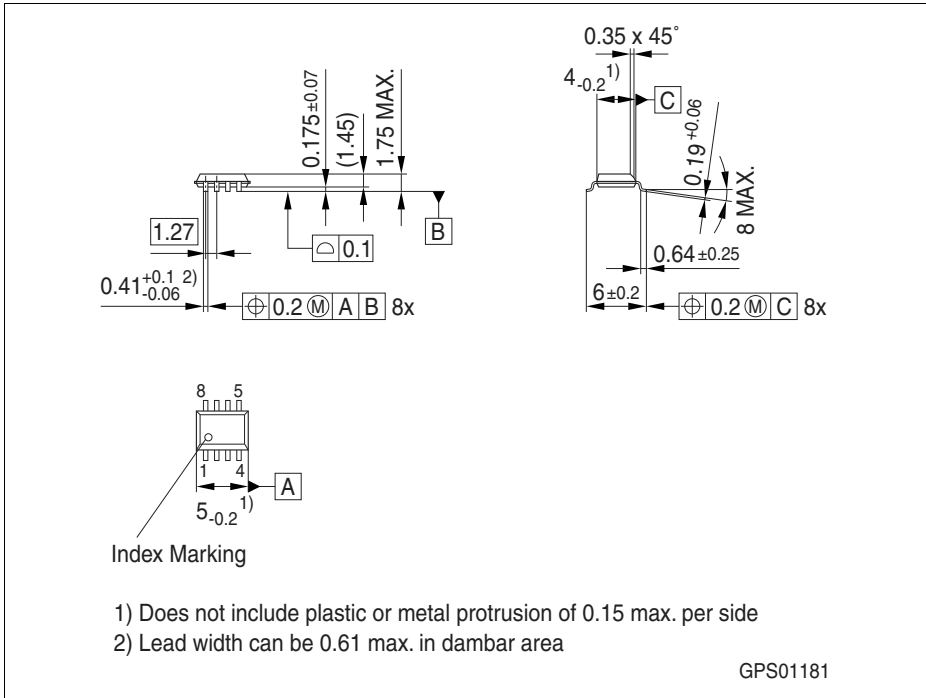

Figure 9 PG-DSO-8-36 (Plastic Green Dual Small Outline Package)

Green Product (RoHS compliant)

To meet the world-wide customer requirements for environmentally friendly products and to be compliant with government regulations the device is available as a green product. Green products are RoHS-Compliant (i.e Pb-free finish on leads and suitable for Pb-free soldering according to IPC/JEDEC J-STD-020).

Revision History

Version	Date	Changes
Rev. 1.5	2017-11-20	Updates in wording/spelling in the Logic Supply description
Rev. 1.4	2013-02-12	Minor updates in wording/spelling; updated table foot note of Maximum Ratings and Protection Functions - added: "not subject to production test." updated reference of ESD standard; removed chapter "EMC characteristics"; updated test condition for parameter t_{on} and t_{off} ; added parameter "Inverse diode forward voltage";
Rev. 1.3	2008-01-09	Changed package outline drawing, updated package name
Rev. 1.2	2007-06-15	Released automotive green version Package parameter (humidity and climatic) removed in Maximum ratings AEC icon added RoHS icon added Green product (RoHS-compliant) added to the feature list AEC Stress Test Qualification added to the feature list Package information updated to green Green explanation added removed order number
Rev. 1.1	2005-10-10	Released production version

Edition 2017-11-20

**Published by
Infineon Technologies AG
81726 Munich, Germany**

**© 2017 Infineon Technologies AG
All Rights Reserved.**

Legal Disclaimer

The information given in this document shall in no event be regarded as a guarantee of conditions or characteristics. With respect to any examples or hints given herein, any typical values stated herein and/or any information regarding the application of the device, Infineon Technologies hereby disclaims any and all warranties and liabilities of any kind, including without limitation, warranties of non-infringement of intellectual property rights of any third party.

Information

For further information on technology, delivery terms and conditions and prices, please contact the nearest Infineon Technologies Office (www.infineon.com).

Warnings

Due to technical requirements, components may contain dangerous substances. For information on the types in question, please contact the nearest Infineon Technologies Office.

Infineon Technologies components may be used in life-support devices or systems only with the express written approval of Infineon Technologies, if a failure of such components can reasonably be expected to cause the failure of that life-support device or system or to affect the safety or effectiveness of that device or system. Life support devices or systems are intended to be implanted in the human body or to support and/or maintain and sustain and/or protect human life. If they fail, it is reasonable to assume that the health of the user or other persons may be endangered.