

12-V Voice Coil Motor Driver

DESCRIPTION

The Si9961A is a linear actuator (voice coil motor) driver suitable for use in disk drive head positioning systems. The Si9961A contains all of the power and control circuitry necessary to drive the VCM that is typically found in 3¹/₂ inch hard disk drives and optical disk drives. The driver is capable of delivering 1.8 A at a nominal supply of 12 V.

The Si9961A provides all necessary functions including a motor current sense amplifier, a loop compensation amplifier and a power amplifier featuring four complementary MOSFETs in a H-bridge configuration. The output crossover protection ensures no cross-conducting current and true Class B operation during linear tracking. Externally programmable gain switch at the input summing junction increases the resolution and dynamic range for a given DAC. The head retract circuitry can be activated by either an undervoltage condition or an external command. An external resistor is required to set the VCM current during retract.

The Si9961A is constructed on a self-isolated BiC/DMOS power IC process. The IC is available in both standard and lead (Pb)-free, 24-pin SO packages for operation over the commercial, C suffix (0 to 70 °C) temperature range.

FEATURES

- 1.8 A H-Bridge Output
- Class B Linear Operation
- Externally Programmable Gain and Bandwidth
- Undervoltage Head Retract
- Programmable Retract Current
- Low Standby Current
- Rail-to-Rail Output Swing
- Single 12 V Supply
- System Voltage Monitor with Fault Output

FUNCTIONAL BLOCK DIAGRAM

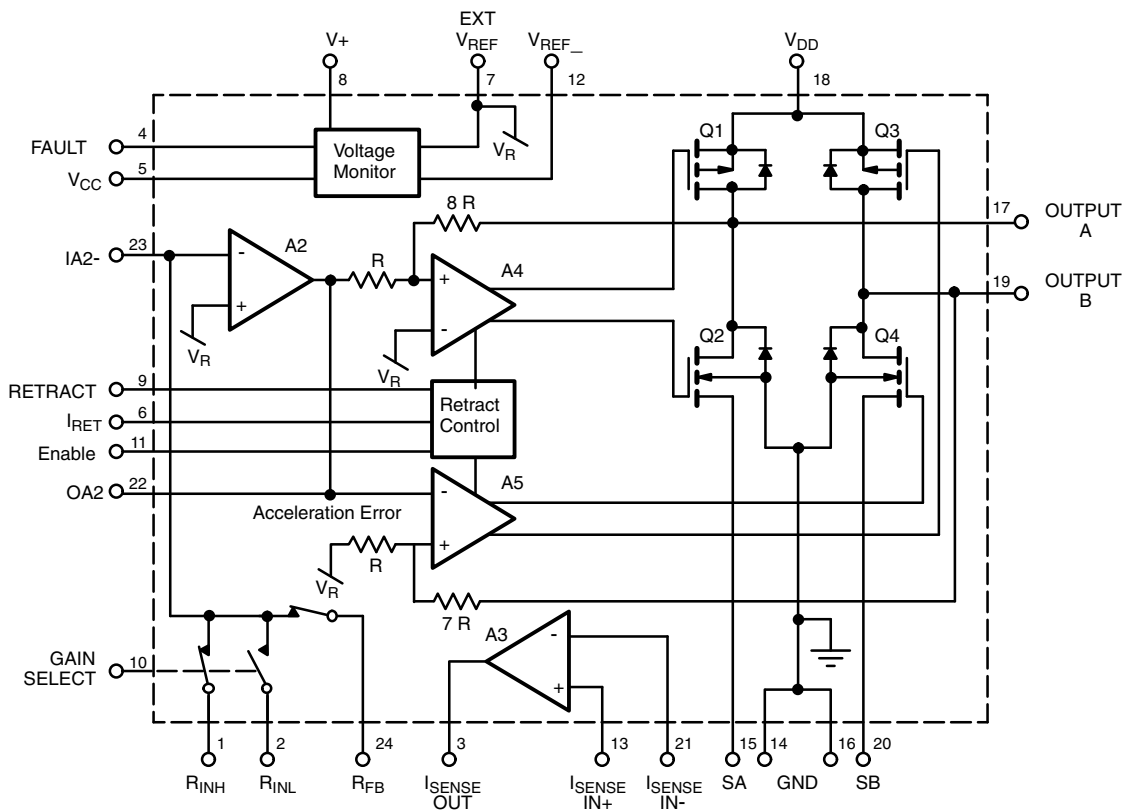

ABSOLUTE MAXIMUM RATINGS			
Parameter		Limit	Unit
Voltages Referenced to Common Pin			
V+ Supply Range		- 0.3 V to 16 V	V
Pin (FAULT)		-0.3 V to V _{CC} + 0.3 V	
Pin (Output A & B, Source A & B)		- 0.3 V to V _{DD} + 0.3 V	
Pin (All Others)		- 0.3 V to V+ + 0.3 V	
Maximum Clamp Current Output A, Output B (Pulsed 10 ms at 10 % duty cycle)		± 1.8	A
Pin (All Others)		± 20	mA
Storage Temperature		- 65 to 150	°C
Operating Temperature		0 to 70	
Junction Temperature (T _J)		150	
Power Dissipation (Package) ^a	24-Pin SOIC ^b	3.125	W
Thermal Impedance (θ _{JA}) ^a	24-Pin SOIC	40	°C/W

Notes:

a. Device Mounted with all leads soldered or welded to PC board.

b. Derate 25 mW/°C above 25 °C.

Stresses beyond those listed under "Absolute Maximum Ratings" may cause permanent damage to the device. These are stress ratings only, and functional operation of the device at these or any other conditions beyond those indicated in the operational sections of the specifications is not implied. Exposure to absolute maximum ratings conditions for extended periods may affect device reliability.

SPECIFICATIONS						
Parameter	Symbol	Test Conditions Unless Otherwise Specified V+ = 12 V ± 10 %, V _{DD} = 11.6 V ± 10 % V _{CC} = 5 V ± 10 %, V _{REF-} = GND = 0 V V _{REF} = 5 V ± 5 %	Limits C Suffix 0 to 70 °C			Unit
			Min ^b	Typ ^a	Max ^b	
Bridge Outputs (A₄, A₅)						
High Level Output Voltage	V _{OH}	I _{OH} = 1.0 A, V _{DD} = 10.2 V, OA ₂ = V _{REF} ± 1 V	8.0	9.1		V
Low Level Output Voltage	V _{OL}	I _{OL} = - 1.0 A, OA ₂ = V _{REF} ± 1 V		0.6	1.1	
Clamp Diode Voltage	V _{CL}	I _F = 1.0 A, ENABLE = High			2.5	
Amplifier Gain		Output V _{RANGE} = V _{REF} ± 2 V	12	16	18	V/V
Dynamic Crossover Current		Measured at V _{DD}		10		mA
Slew Rate	SR		1			V/μS
Small Signal Bandwidth (- 3 dB)				0.2		MHz
Input Deadband			- 60		60	mV
A₂, Loop Compensation Amplifier						
Input Offset Voltage	V _{OS}		- 8		8	mV
Input Bias Current	I _B	Gain Select = High, IA ₂₋ = 5 V	- 50		50	nA
Unity Gain Bandwidth		R _{LOAD} = 10 kΩ, C _{LOAD} = 100 pF to V _{REF}		1		MHz
Slew Rate	SR		1			V/μs
Power Supply Rejection Ratio	PSRR	at 10 kHz		50		dB
Open Loop Voltage Gain	A _{VOL}			80		
Output Voltage Swing	V _O	R _{LOAD} = 10 kΩ to V _{REF}	V _{REF} - 2		V _{REF} + 2	V
A₃, Current Sense Amplifier						
Input Offset Voltage	V _{OS}		- 5		5	mV
Input Impedance	R _{IN}	I _{SENSE} IN+ to I _{SENSE} IN-		5		kΩ
Small Signal Bandwidth (- 3 dB)		R _{LOAD} = 10 kΩ, C _{LOAD} = 100 pF to V _{REF}		1		MHz
Common Mode Rejection Ratio	CMRR	at 5 kHz		50		dB
Slew Rate	SR		2			V/μs
Gain			3.9	4	4.1	V/V
Input Common-Mode Voltage Range	V _{CM}	To GND	- 0.3		2	V
Output Voltage Swing	V _O	R _{LOAD} = 10 kΩ, C _{LOAD} = 100 pF to V _{REF}	V _{REF} - 2		V _{REF} + 2	



SPECIFICATIONS						
Parameter	Symbol	Test Conditions Unless Otherwise Specified $V_+ = 12\text{ V} \pm 10\%$, $V_{DD} = 11.6\text{ V} \pm 10\%$ $V_{CC} = 5\text{ V} \pm 10\%$, $V_{REF-} = \text{GND} = 0\text{ V}$ $V_{REF} = 5\text{ V} \pm 5\%$	Limits C Suffix 0 to 70 °C			Unit
			Min ^b	Typ ^a	Max ^b	
Supply						
Supply Current (Normal)	I_{CC}	Static, No Load $\overline{\text{RETRACT}} = \text{High}$ $\overline{\text{ENABLE}} = \text{Low}$			0.01	mA
	I_{V+}			2	5	
	I_{DD}			5	13	
Supply Current (Standby)	I_{CC}	Static, No Load $\overline{\text{RETRACT}} = \text{High}$ $\overline{\text{ENABLE}} = \text{High}$			0.01	
	I_{V+}			0.2	0.4	
	I_{DD}			0.8	1.6	
V_{DD} Range	V_{DD}	Normal Mode	10.2	11.6	13.2	V
		Retract Mode	2.0		14	
V_{CC} Range	V_{CC}		4.5	5	5.5	
V_+ Range	V_+		10.8	12	13.2	
Gain Select Switch						
R_{FB} Switch Resistance				108	240	Ω
R_{INH} Switch Resistance		$I_{A2} = 5\text{ V}$		135	300	
R_{INL} Switch Resistance				810	1800	
V_{REF} (EXT)						
Input Current	I_{REF}	$OA2 = V_{REF}$	0.15	0.40	0.65	mA
External Voltage Range	V_{REF}		4.75	5	5.25	V
Power Supply Monitor						
V_{CC} Undervoltage Threshold		$V_{REF} = 5.0\text{ V}$	3.82	4.12	4.42	V
Hysteresis				40		mV
V_+ Undervoltage Threshold		$V_{REF} = 5.0\text{ V}$	9.1	9.8	10.6	V
Hysteresis				100		mV
Gain Select, $\overline{\text{RETRACT}}$, $\overline{\text{ENABLE}}$ Input						
Input High Voltage	V_{IH}		3.5			V
Input Low Voltage	V_{IL}				1.5	
Input High Current	I_{IH}	$V_{IN} = 5\text{ V}$	- 1		1	μA
Input Low Current	I_{IL}	$V_{IN} = 0\text{ V}$	- 1		1	
FAULT Output						
Output High Voltage	V_{OH}	$I_{OH} = - 100\text{ μA}$	$V_{CC} - 0.8$	$V_{CC} - 0.33$		V
Output Low Voltage	V_{OL}	$I_{OL} = 1.6\text{ mA}$		0.25	0.50	
Output High Sourcing Current	I_{OHS}	$V_{OUT} = 0\text{ V}$		400	1100	μA
RETRACT Current Control ($\overline{\text{RETRACT}} = \text{Low}$, Output Current from A to B)						
I_{RET} Bias Voltage	$V(I_{RET})$	$V_{DD} = 10\text{ V}$, $R_{RET} = 3.74\text{ k}\Omega$		0.66		V
Retract Output Pull-Up Voltage	V_{OUTA}	$V_{DD} = 2.5\text{ V}$ to 14 V, $I_{OUTA} = 30\text{ mA}$	$V_{DD} - 1$			
Retract Output Pull-Down Current	I_{OUTB}	$V_{DD} = 10\text{ V}$, $V_{OUTB} = 5\text{ V}$, $R_{RET} = 3.74\text{ k}\Omega$ $R_{SB} = 0.5\text{ }\Omega$, $T_A = 25\text{ }^\circ\text{C}$	22	30	38	mA
Maximum Emergency Retract Current	$I_{OUTB} (\text{Max})$	$V_{DD} = 2\text{ V}$, $V_{OUTB} = 0.7\text{ V}$, $R_{RET} = < 10\text{ }\Omega$ $R_{SB} = 0.5\text{ }\Omega$	40			
Retract Current V_{DD} Supply Rejection Ratio		$V_{DD} = 2\text{ V}$ to 14 V, $R_{RET} = 3.74\text{ k}\Omega$		3.0		%/V
Retract Current Temperature Coefficient		$V_{DD} = 10\text{ V}$, $R_{RET} = 3.74\text{ k}\Omega$		- 0.3		%/°C

Notes:

a. Typical values are for DESIGN AID ONLY, not guaranteed nor subject to production testing.

b. The algebraic convention whereby the most negative value is a minimum and the most positive a maximum.

PIN CONFIGURATION AND ORDERING INFORMATION

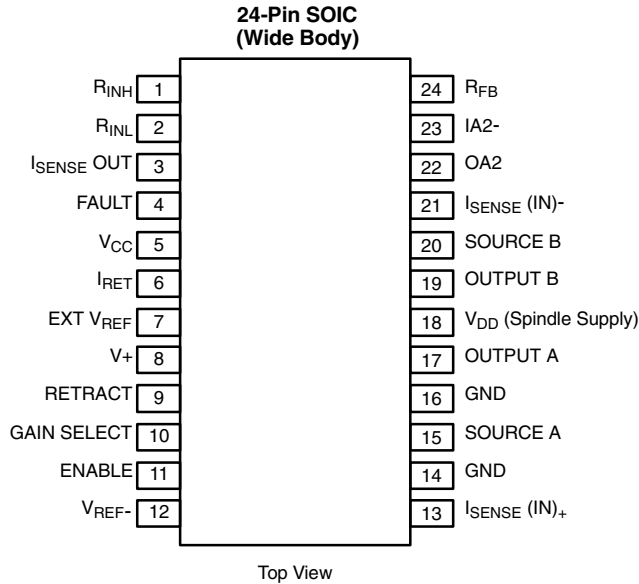

ORDERING INFORMATION			
Part Number	Lead (Pb)-free Part Number	Temperature Range	Package
Si9961ACY		0 to 70 °C	SOIC-24 (Wide Body)
Si9961ACY-T1	Si9961ACY-T1-E3		

APPLICATIONS

Introduction

The Si9961A Voice Coil Motor (VCM) driver integrates the active feedback and drive components of a head-positioning servo loop for high-performance hard-disk applications. The Si9961A operates from a 12 V ($\pm 10\%$) power supply and delivers 1 A of steady-state output current. This device is made possible by a power IC process which combines bipolar, CMOS and complimentary DMOS technologies. CMOS logic and linear components minimize power consumption, bipolar front-ends on critical amplifiers provide necessary accuracy, and complimentary (P- and N-Channel) DMOS devices allow the transconductance output amplifier to operate from ground to V_{DD} . Two user-programmable, current feedback/input voltage ratios may be digitally selected to optimize gain for both seek and track following modes, to maximize system accuracy for a given DAC resolution. An undervoltage lockout circuit monitors the $V+$ supply and generates a fault signal to trigger an orderly head-retract sequence at a voltage level sufficient to allow the spindle motor's back EMF-generated voltage to supply the necessary head parking energy. Head retract can also be commanded via a separate $\overline{\text{RETRACT}}$ input. VCM current during retract can be user programmed with a single external resistor. External components are limited to R/C filter components for loop compensation and the resistors that are required to program gain, retract current, and the load current sense.

User-Programmable Gains

During linear operation, the transconductance amplifiers' gains (input voltage at V_{IN} vs. VCM current, in Figure 1) are set by external resistors $R_3 \rightarrow R_5$, R_{SA} , and R_{SB} and selected by gain input. After selecting a value for R_{SA} and R_{SB} that will yield the desired VCM current level, the High and Low feedback gain ratios may be determined by the following:

$$\text{High Gain} = \left(\frac{R_5}{R_3} \right) \frac{1}{4 R_S} \quad (\text{GAIN SELECT Input} = \text{High})$$

$$\text{Low Gain} = \left(\frac{R_5}{R_4} \right) \frac{1}{4 R_S} \quad (\text{GAIN SELECT Input} = \text{Low})$$

Where $R_S = R_{SA} = R_{SB}$

Input offset current may then be calculated as:

$$I_{OS} = \frac{1}{4 R_S} \left(\left(\frac{R_S + R_{IN}}{R_{IN}} V_{OSA2} \right) + 5 V_{IAS3} \right)$$

Where $R_{IN} = R_3$ or R_4

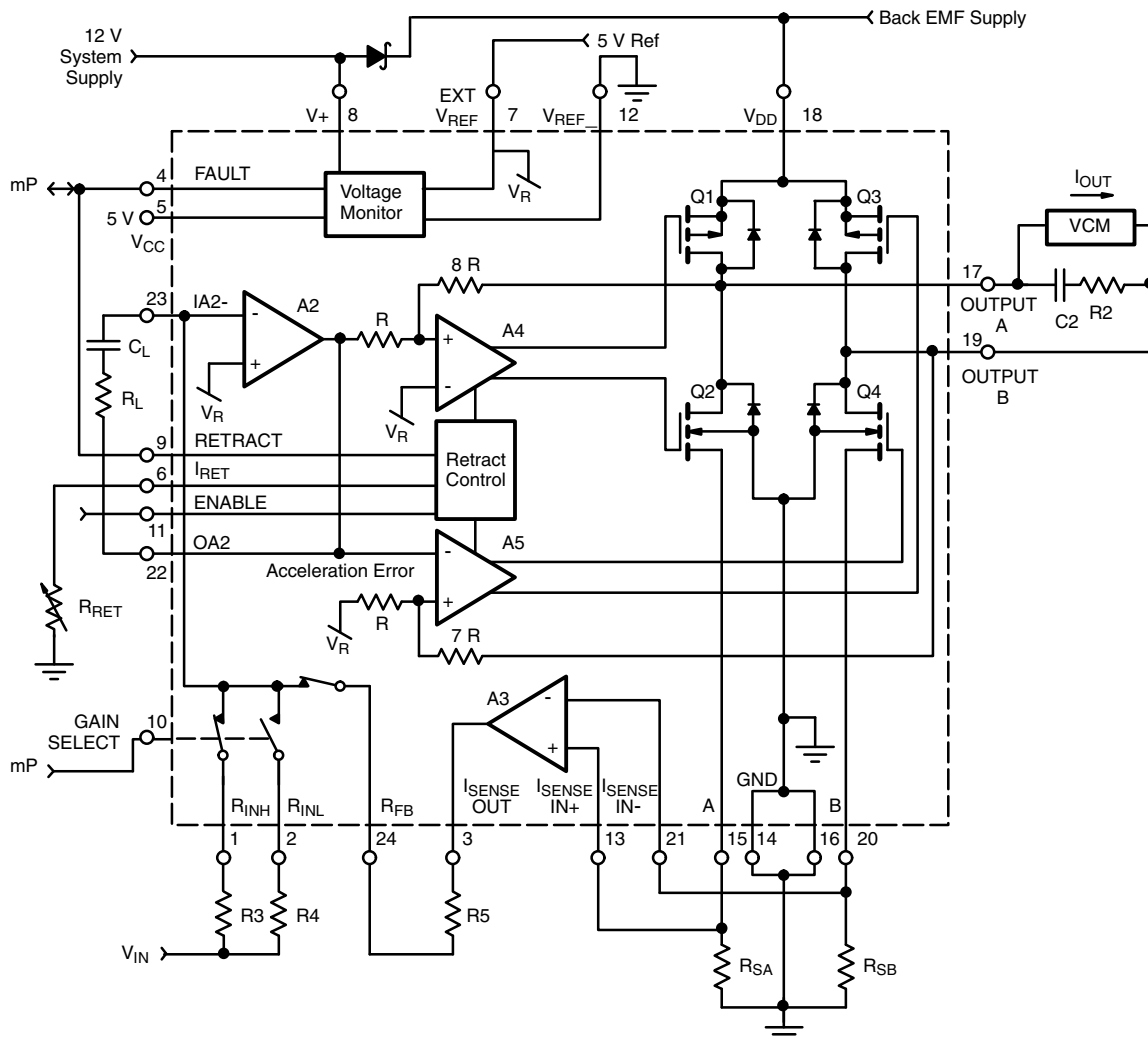

Figure 1. Si9961A Typical Application

Head Retract

A low on the $\overline{\text{RETRACT}}$ input pin turns output devices Q1 and Q4 on, and output devices Q2 and Q3 off. Maximum VCM current can be set during head retract by adding an external resistor between the IRET pin and ground. Maximum retract current may be calculated as:

$$I_{\text{OUT}} = 175 \times I_{\text{ret}} = 175 \times \frac{0.66 \text{ V}}{R_{\text{ret}}}$$

Head retract can be initiated automatically by an undervoltage condition (either the 12 V or 5 V supplies on the Si9961A) by connecting the $\overline{\text{FAULT}}$ output to the $\overline{\text{RETRACT}}$ input.

A high $\overline{\text{ENABLE}}$ input puts both driver outputs in a high-impedance state. The $\overline{\text{ENABLE}}$ function can be used to eliminate quiescent output current when power is applied but the head has been parked, such as a sleep mode. A sleep-mode power down sequence should be preceded by a retract signal since a power failure during this state may not provide adequate spindle-motor back EMF to permit head retraction.

Transconductance Amplifier Compensation

The Si9961A features an integrated transconductance amplifier to drive the voice coil motor (VCM). To ensure proper operation, this amplifier must be compensated specifically for the VCM being driven. As a first approximation, the torque constant and inertia of the VCM may be ignored, although they will have some influence on the final results, especially if large values are involved. (See Figure 1.)

Vishay Siliconix

Frequency Compensation:

The VCM transconductance (in siemens) of this simplified case may be expressed in the s (Laplace) plane as:

$$g_v = \frac{1}{s + \frac{R_v}{L_v}}$$

Where R_v = VCM resistance in ohms
 L_v = VCM inductance in henrys
 s is the Laplace operator

In this case, the transconductance pole is at $-R_v/L_v$. It is desirable to cancel this pole in the interest of stability. To do this, a compensation amplifier is cascaded with the VCM and its driver. The transfer function of this amplifier is:

$$H_c = A \times \frac{\left(s + \frac{1}{R_L \times C_L}\right)}{s}$$

Where R_L = Compensation amplifier feedback resistor in ohms
 C_L = Compensation amplifier feedback capacitor in farads
 A = Compensation amplifier and driver voltage gain at high frequency

If $R_L \times C_L$ is set equal to L_v/R_v , then the combined open loop transconductance in siemens becomes:

$$g_{to} = \frac{A}{s \times L_v}$$

In this case, the transconductance has a single pole at the origin. If this open loop transfer is closed with a transimpedance amplifier having a gain of B ohms, the resultant closed loop transconductance stage has the transfer function (in siemens) of:

$$g_{tc} = \frac{\frac{A}{L_v}}{s + \frac{A \times B}{L_v}}$$

Where B = Current feedback transimpedance amplifier gain in ohms.

The entire transconductance now contains only a single pole at $-A*B/L_v$. A and B are chosen to be considerably higher than the servo bandwidth, to avoid undue phase margin reduction.

As a typical example, in the referenced schematic, assume that R_{sa} and $R_{sb} = 0.5 \Omega$, $R_5 = R_3 = 10 \text{ k}\Omega$, VCM inductance (L_v) = 1.5 mH, VCM resistance (R_v) = 15 Ω . Hence:

$$\begin{aligned} R_v &= 15 \Omega \\ L_v &= 1.5 \text{ mH} \\ B &= 2 \Omega \\ A &= 16 \times R_L / 10000 \\ C_L &= L_v / (R_v \times R_L) = 100 \times 10^{-6} / R_L \text{ farads} \end{aligned}$$

Gain Optimization:

There are three things to consider when optimizing the gain (A) above. The first is servo bandwidth. The main criterion here is to avoid having the transconductance amplifier cause an undue loss of phase margin in the overall servo (mechanical + electrical + firmware) loop. The second is to avoid configuring a bandwidth that is more than required in view of noise and stability considerations. The third is to keep the voltage output waveform overshoot to a level that will not cause cross-conduction of the output FETs.

The first two problems can be considered together. Let us assume a disk drive with a spindle RPM of 4400 and with 50 servo sectors per track. The sample rate is therefore:

$$f_s = 50 \times \frac{440}{60} \quad \text{This is a sample frequency of 3667 Hz}$$

As a rule of thumb, the open loop unity gain crossover frequency of the entire servo (mechanical + electrical + firmware) loop should be less than 1/10 of the sample frequency. In this example, the servo open loop unity gain crossover frequency would be less than 367 Hz. If we allow only a 10° degradation in phase margin due to the transconductance amplifier, then a phase lag of 10° at 367 Hz is acceptable. This results in a 3 dB point in the transconductance at :

$$f_{3db} = \frac{367}{\tan(10)}$$

or a 3 dB point in the transconductance at 2081 Hz.

The pole in the closed loop transconductance ($-A * B / L_v$) should then be $2081 * 2 * \pi = 13075$. This means that $A = 9.8$. From the above equation for A, $R_L = 6.2 \text{ k}\Omega$. This sets the minimum gain limit governed by the servo bandwidth requirements. The gain should not be much greater than this, since increased noise will degrade the servo response.

The third problem, keeping the transconductance amplifier voltage output wave form overshoot to a level that will not cause the wrong output FETs to conduct, can be evaluated by deriving the voltage transfer function of the closed loop transconductance amplifier from input voltage to output voltage (V_{in} to output A and B on the reference schematic).

This is :

$$H_{to} = A \times \frac{s + p}{s + x}$$

Where $p = 1/R_L \times C_L$ or R_v/L_v Comp amplifier zero/VCM pole
 $x = A \times B/L_v$ closed loop pole

If a unit step voltage is applied to the above transfer function and the inverse Laplace transform is taken, the output result is:

$$V_O = A \times \frac{p + (x - p) x e^{-x \times t}}{x}$$

Where t = time

As we can see, if $x = p$ (i.e. if the VCM pole and compensation amplifier zero = the transconductance closed loop pole), then V_O reduces to A . In other words, a step input results in a step output without overshoot. If $x < p$ then a step input results in an increased rise time output and no overshoot. If $x > p$, a step input results in a step output with an overshoot.

If this overshoot is large enough, there may be a cross-conduction condition in the output FETs.

Let us look at the above equation at $t = 0$ and $t \gg 0$, expressed in terms of the open loop high frequency voltage gain, A .

$$V_O = A \quad \text{At } t = 0$$

$$V_O = \frac{p \times L_v}{B} \quad \text{At } t \gg 0$$

In the example shown above, $p = 10,000$ and $A = 9.8$. This means that there is some overshoot. At $t = 0$, the output voltage is 9.8 V per volt of input. At some later time, it has dropped to 7.5 V per volt of input. An overshoot of 31 % is thus produced.

The maximum overshoot voltage requires careful consideration, since it constitutes a potentially catastrophic problem area. If we had decided to optimize for no overshoot, A would equal 7.5, and hence the closed loop pole ($A \times B / L_v$) would be 10,000, which is a frequency of 1.592 kHz. This would have resulted in a phase margin degradation of 13° at the 367 Hz frequency desired. This may or may not be acceptable. One must weigh the servo bandwidth, phase margin degradation, and maximum voltage at the VCM for each individual case.

Result:

In the example for the 2081 Hz roll-off case with 31 % overshoot and proper pole cancellation, the compensation values are:

$$R_L = 6.2 \text{ k}\Omega$$

$$C_L = 0.016 \text{ }\mu\text{F}$$

In the example for the 1592-Hz roll-off case with no overshoot and proper pole cancellation, the compensation values are:

$$R_L = 4.7 \text{ k}\Omega$$

$$C_L = 0.022 \text{ }\mu\text{F}$$

The linearity of the transconductance amplifier (around a center value of 500 mA/volt) is shown in Figure 2. In this case, the output current sense resistors (R_{SA} and R_{SB}) were $\pm 5\%$ tolerance, 0.5Ω . Any mismatch between R_{SA} and R_{SB} contribute directly to mismatch between the positive and negative "full-scale". Including the external resistor mismatch, the overall loop nonlinearity is approximately 1 % maximum over a ± 250 mV input voltage range.

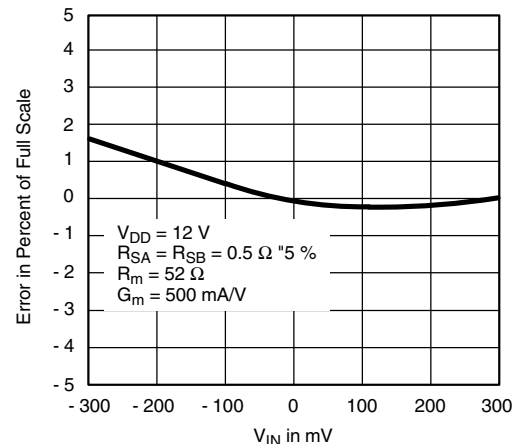

Figure 2. Si9961A Transconductance End Point Non-Linearity

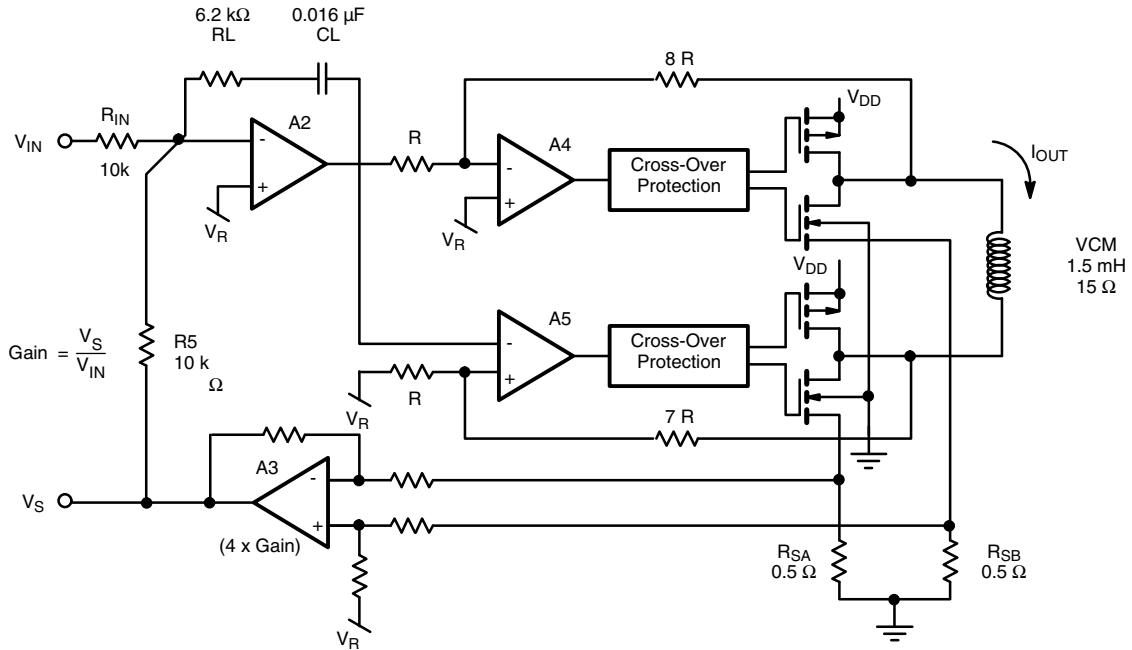

Figure 3. Transconductance Amplifier

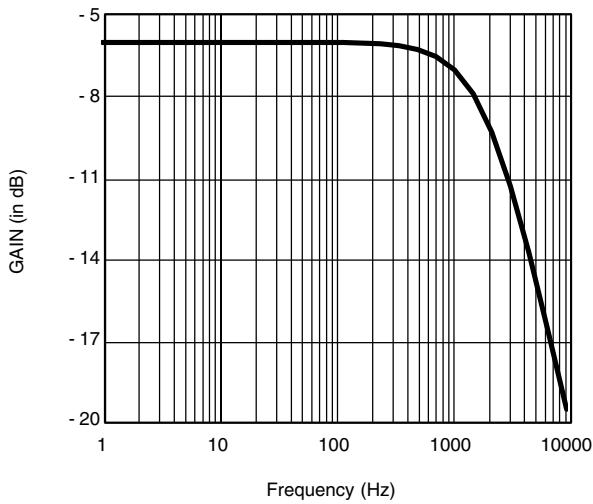

Figure 4. $R_L = 6.2 \text{ k}\Omega$, $C_L = 0.016 \text{ }\mu\text{F}$

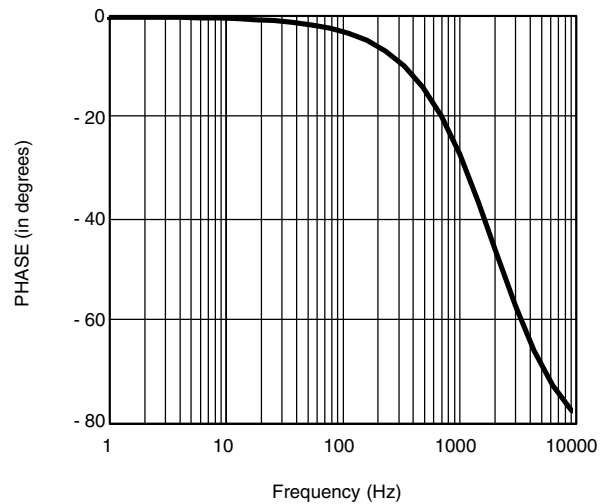
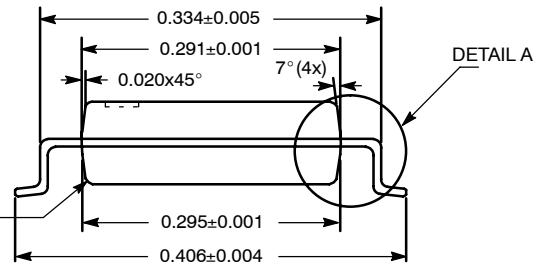
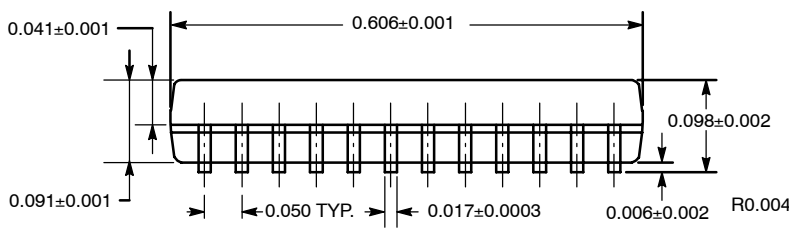
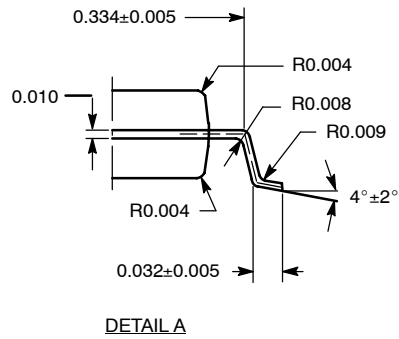
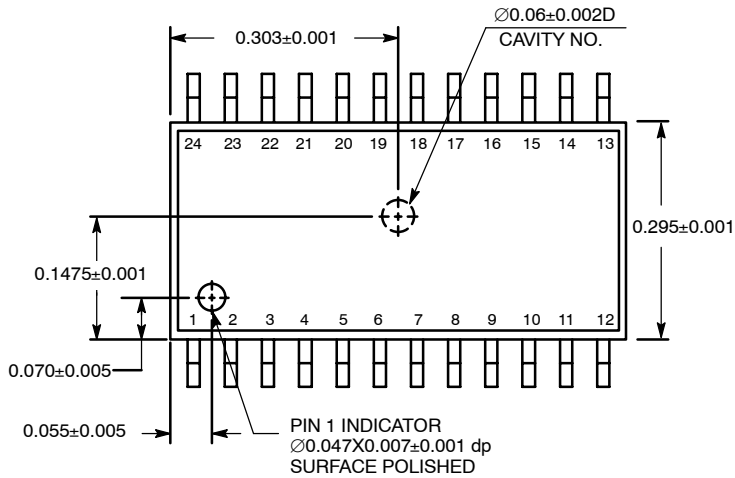

Figure 5. $R_L = 6.2 \text{ k}\Omega$, $C_L = 0.016 \text{ }\mu\text{F}$

Vishay Siliconix maintains worldwide manufacturing capability. Products may be manufactured at one of several qualified locations. Reliability data for Silicon Technology and Package Reliability represent a composite of all qualified locations. For related documents such as package/tape drawings, part marking, and reliability data, see <http://www.vishay.com/ppg?70014>.



SOIC (WIDE-BODY): 24-LEAD (POWER IC ONLY)



ECN: S-40085—Rev. A, 02-Feb-04
DWG: 5930



Disclaimer

ALL PRODUCT, PRODUCT SPECIFICATIONS AND DATA ARE SUBJECT TO CHANGE WITHOUT NOTICE TO IMPROVE RELIABILITY, FUNCTION OR DESIGN OR OTHERWISE.

Vishay Intertechnology, Inc., its affiliates, agents, and employees, and all persons acting on its or their behalf (collectively, "Vishay"), disclaim any and all liability for any errors, inaccuracies or incompleteness contained in any datasheet or in any other disclosure relating to any product.

Vishay makes no warranty, representation or guarantee regarding the suitability of the products for any particular purpose or the continuing production of any product. To the maximum extent permitted by applicable law, Vishay disclaims (i) any and all liability arising out of the application or use of any product, (ii) any and all liability, including without limitation special, consequential or incidental damages, and (iii) any and all implied warranties, including warranties of fitness for particular purpose, non-infringement and merchantability.

Statements regarding the suitability of products for certain types of applications are based on Vishay's knowledge of typical requirements that are often placed on Vishay products in generic applications. Such statements are not binding statements about the suitability of products for a particular application. It is the customer's responsibility to validate that a particular product with the properties described in the product specification is suitable for use in a particular application. Parameters provided in datasheets and / or specifications may vary in different applications and performance may vary over time. All operating parameters, including typical parameters, must be validated for each customer application by the customer's technical experts. Product specifications do not expand or otherwise modify Vishay's terms and conditions of purchase, including but not limited to the warranty expressed therein.

Hyperlinks included in this datasheet may direct users to third-party websites. These links are provided as a convenience and for informational purposes only. Inclusion of these hyperlinks does not constitute an endorsement or an approval by Vishay of any of the products, services or opinions of the corporation, organization or individual associated with the third-party website. Vishay disclaims any and all liability and bears no responsibility for the accuracy, legality or content of the third-party website or for that of subsequent links.

Except as expressly indicated in writing, Vishay products are not designed for use in medical, life-saving, or life-sustaining applications or for any other application in which the failure of the Vishay product could result in personal injury or death. Customers using or selling Vishay products not expressly indicated for use in such applications do so at their own risk. Please contact authorized Vishay personnel to obtain written terms and conditions regarding products designed for such applications.

No license, express or implied, by estoppel or otherwise, to any intellectual property rights is granted by this document or by any conduct of Vishay. Product names and markings noted herein may be trademarks of their respective owners.