

LT8722
Monolithic Thermoelectric
Cooler Driver

DESCRIPTION

Demonstration circuit 3145A demonstrates a high efficiency thermoelectric cooler driver and features the [LT8722](#) monolithic driver.

The input voltage range of the DC3145A is from 3.1V to 15V and the output is a SPI programmable differential voltage output. The maximum output current is 4A.

The switching frequency SPI programmable from 500kHz to 3MHz.

The LT8722 is controlled through an SPI interface and therefore the demonstration circuit is also setup to interface through SPI. For demonstration purposes this manual provides instruction on how to connect the DC2026C Linduino board to monitor and control the DC3145A with a PC using a command line Arduino IDE interface.

Demo Board Features

- The (JP2) connector is intended to connect to the DC2026C through a ribbon cable.
- The (JP1) jumper has two positions; ENABLE and LIN. Ensure the jumper is connected to ENABLE to enable the LT8722.
- The (JP3) jumper has two positions; MANUAL and LIN. Ensure the jumper is connected to MANUAL.
- The SYNC input can be used to sync LT8722 with an external signal. There are also terminals that make it easy to monitor the various points in the circuit.
- Aout is an analog output of the LT8722 and can be used to output various signals as described in the LT8722 data sheet. A DVM can be used to monitor the Aout signal.

[Design files for this circuit board are available.](#)

All registered trademarks and trademarks are the property of their respective owners.

BOARD PHOTO

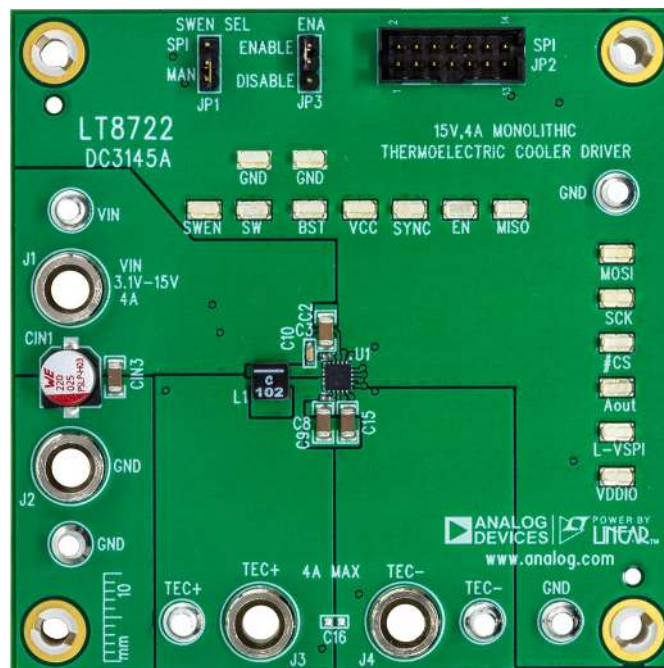

DEMO MANUAL DC3145A

PERFORMANCE SUMMARY Specifications are at $T_A = 25^\circ\text{C}$

PARAMETER	CONDITIONS	MIN	TYP	MAX	UNITS
Minimum Input Voltage, V_{IN}				3.1	V
Maximum Input Voltage, V_{IN}		15			V
Output Voltage, V_{OUT}				V_{IN}	V
Output current, I_{OUT}				4	A
Efficiency	$V_{IN} = 15\text{V}$, $I_{OUT} = 4\text{A}$, 3MHz		92.6		%
Switching Frequency			2		MHz

QUICK START PROCEDURE

To evaluate the performance of DC3145A follow procedure below.

1. Set the DC2026C JP3 link to 3.3V as shown in Figure 1.
2. As shown in Figure 5.
 - a. Connect DC2026C to LT8722 demo board.
 - b. Connect to TEC load as shown in Figure 2. TEC+ and TEC- correspond to the DC3145A banana jacks with the same labels.
 - c. Connect a voltmeter.
 - d. Connect USB cable from DC2026C to PC.
 - e. Connect bench top power supply to LT8722 demo board and ensure voltage is set between 3.1V and 15V.
3. Refer to dc2026cfe.pdf for Linduino software initial setup. Instructions and files for Linduino can be found by searching DC2026C on the Analog website or by clicking [here](#). Once installed proceed to the next step.
4. Start the Arduino/Linduino software.
5. Set the Sketchbook location under File → Preferences → Settings.
6. Download the LT8722_App0.ino Sketch file which can be found under Resources for the DC3145A evaluation kit or by clicking [here](#).
7. Open the LT8722_App0.ino Sketch.
8. Upload the file to the DC2026C board under Sketch → Upload.
9. Next, ensure the Arduino/Linduino software is properly connected to the port for the DC2026C. See Figure 3. The correct port is typically the one with the smallest number however you may need to experiment until you find it.
10. Open the serial monitor under Tools → Serial Monitor
11. Set baud rate to 1M at the bottom of the Serial Monitor window as shown in Figure 4.
12. Commands can now be entered in the command line window of the Serial Monitor. See Linduino (Sketch) Commands section for available commands.

QUICK START PROCEDURE

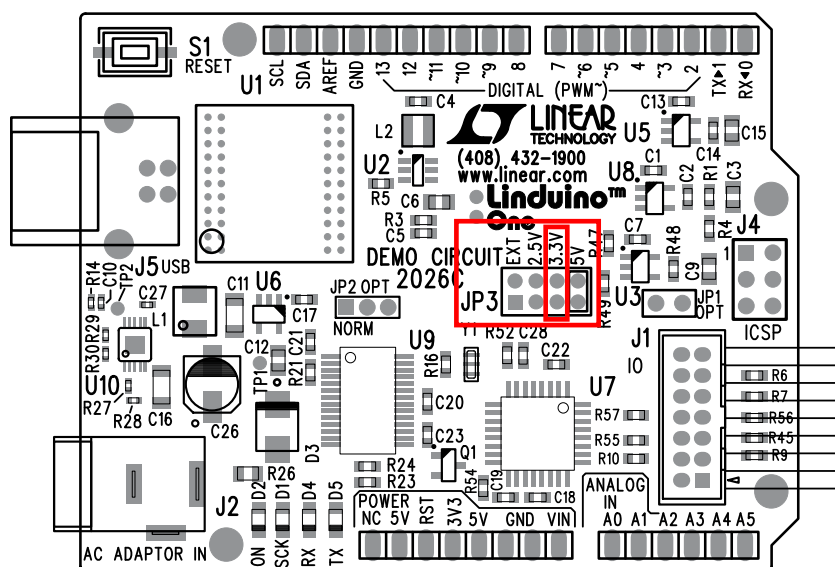

Figure 1. DC2026C Voltage Setting

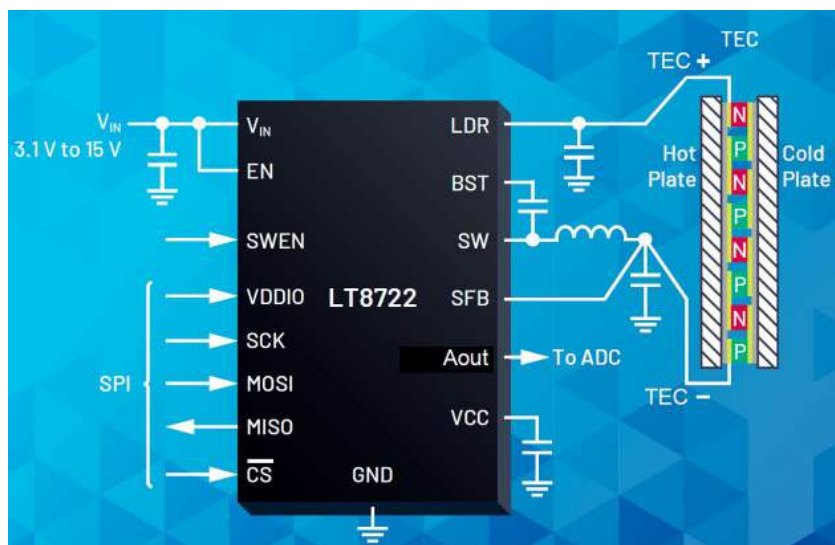

Figure 2. TEC Load Connections

QUICK START PROCEDURE

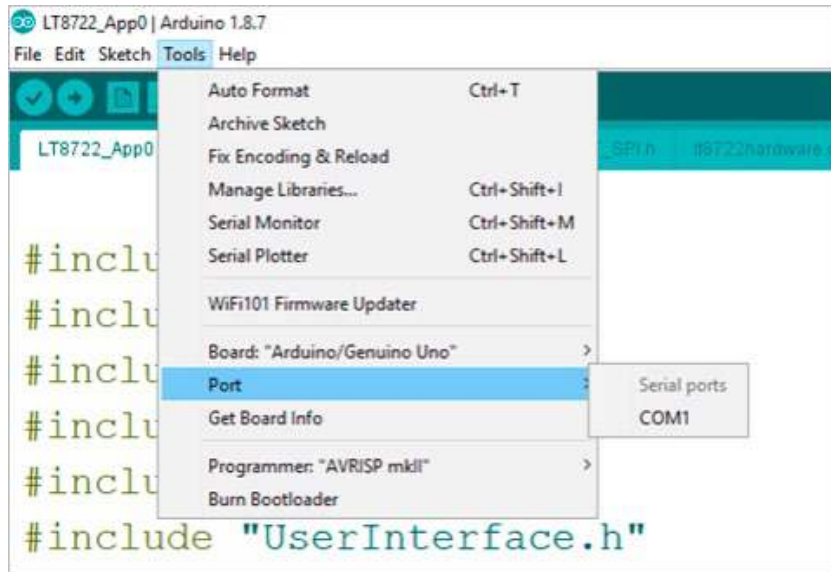

Figure 3. Port Setting



Figure 4. Select Baud Rate

QUICK START PROCEDURE

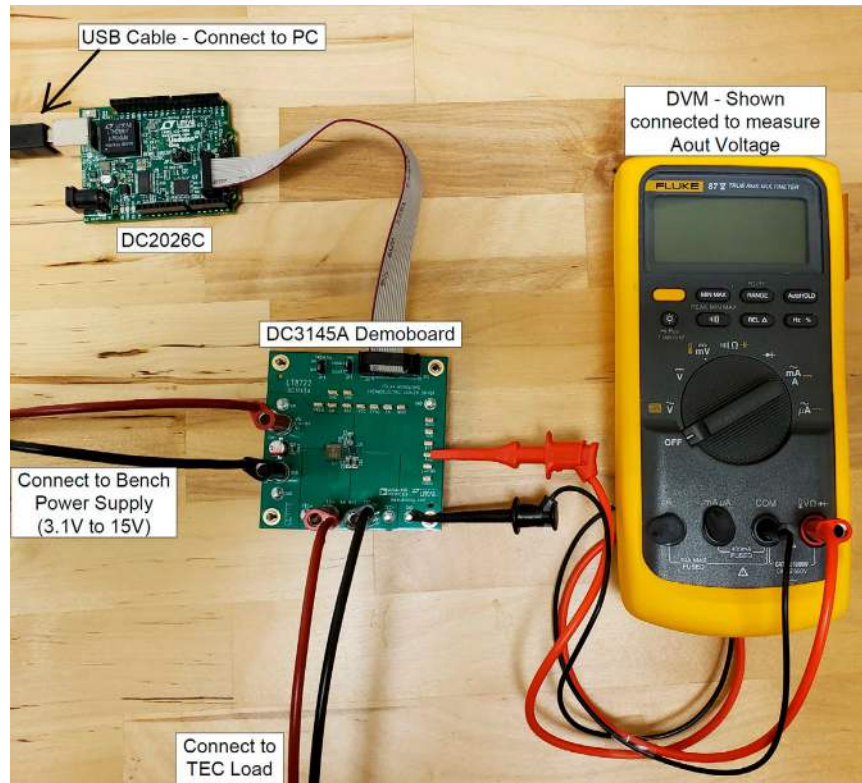

Figure 5. Initial Setup

LINDUINO (SKETCH) COMMANDS

Please refer to the data sheet for register addresses. These registers are 32 bit.

e Command: Read Register Command

Any register as defined in the LT8722 data sheet can be read with this command.

Example: e00 entered in the command line displays the result for the SPIS_COMMAND register (address 00). Entering this command will output a result similar to the following:

```
MOSI:F400400000000000
MISO:00010000120F32A5
```

E Command: Write Register Command

E followed by the register address followed by the data to be written. Examples:

A command line entry of E000000A214 writes the hex value 0000A214 to the SPIS_COMMAND register (address 00).

A Command line entry of E02000001FF writes the hex value 000001FF to the SPIS_DAC_ILIMP register (address 02).

U Command: Soft-Start Command

Entering the U command does a soft-start startup of the LT8722.

The LDR (TEC+) output and SW pin voltage response should be similar to what is shown in Figure 6.

QUICK START PROCEDURE

THERMAL IMAGE

Conditions:

- $V_{IN} = 15V$
- $V_{OUT} = 13.3V, 3.83A$

- Ambient Temperature = 25°C
- Air Flow – Natural Convection

As shown in Figure 7, the LT8722 IC reaches 77°C with demoboard efficiency of 95.1%.



Figure 7. Thermal Image of DC3145A

PARTS LIST

ITEM	QTY	REFERENCE	PART DESCRIPTION	MANUFACTURER/PART NUMBER
Required Circuit Components				
1	1	C1	CAP, 47 μ F, TANT, 20V, 20%, 7343, TAJD, NO SUBS. ALLOWED	AVX TAJD476M020RNJ
2	4	C2, C9, C15, CIN3	CAP., 4.7 μ F, X7R, 25V, 10%, 1206	AVX 12063C475KAT2A MURATA GRM31CR71E475KA88L NIC NMC1206X7R475K25TRPF TAIYO YUDEN TMK316AB7475KL-T
3	2	C3, C8	CAP., 0.1 μ F, X5R, 25V, 10%, 0402	AVX 04023D104KAT2A SAMSUNG CL05A104KA5NNNC TDK C1005X5R1E104K050BC
4	3	C4, C5, CIN4	CAP., 1 μ F, X7R, 25V, 10%, 0603, AEC-Q200	MURATA GCM188R71E105KA64D
5	0	C7, C16, C17, CIN5	CAP., OPTION, 0603	
6	1	C10	CAP., 0.1 μ F, X7R, 25V, 10%, 0603, AEC-Q200	AVX 06033C104K4T4A SAMSUNG CL10B104KA8WPNC

DEMO MANUAL DC3145A

PARTS LIST

ITEM	QTY	REFERENCE	PART DESCRIPTION	MANUFACTURER/PART NUMBER
7	1	C11	CAP., 1000pF, X7R, 25V, 10%, 0603	AVX 06033C102KAT2A AVX 06033C102KAT4A KEMET C0603C102K3RACTU NIC NMC0603X7R102K25TRPF MURATA GRM188R71E102KA01D
8	3	C12, C13, C14	CAP., 0.047µF, X7R, 25V, 10%, 0603	MURATA GRM188R71E473KA01D NIC NMC0603X7R473K25TRPF AVX 06033C473KAT2A
9	2	CIN1, CIN2	CAP., 22µF, ALUM, 25V, 20%, SMD 6.3mm × 5.8mm	WURTH ELEKTRONIK 875105544003
10	0	D1, D2	DIODE, OPTION, SOD-323	
11	6	E1, E2, E3, E4, E5, E6	TEST POINT, TURRET, 0.094" MTG. HOLE, PCB 0.062" THK	MILL-MAX 2501-2-00-80-00-00-07-0
12	15	E7, E8, E9, E10, E11, E12, E13, E14, E15, E16, E17, E18, E19, E20, E21	TEST POINT, SILVER PLATE, PHOSPHOR BRONZE, 3.81mm × 2.03mm, 2.29mm H, SMT	KEYSTONE 5019
13	4	J1, J2, J3, J4	CONN., BANANA JACK, FEMALE, THT, NON-INSULATED, SWAGE, 0.218"	KEYSTONE 575-4
14	2	JP1, JP3	CONN., HDR, MALE, 1×3, 2mm, VERT, ST, THT, NO SUBS. ALLOWED	WURTH ELEKTRONIK 62000311121
15	1	JP2	CONN., HDR, SHROUDED, PLUG, MALE, 2×7, 2mm, VERT, ST, THT, KEYED	MOLEX 87831-1420
16	1	L1	IND., 1.0µH, POWER, 20%, 12A, 9.0mΩ, 4.3mm × 4.3mm, AEC-Q200	COILCRAFT XGL4020-102MEC
17	1	LB1	LABEL SPEC, DEMO BOARD SERIAL NUMBER	BRADY THT-96-717-10
18	4	MP1, MP2, MP3, MP4	STANDOFF, NYLON, SNAP-ON, 0.50"	KEYSTONE 8833
19	1	PCB1	PCB, DC3145A	ADI APPROVED SUPPLIER 600-DC3145A
20	1	R1	RES., 1k, 5%, 1/10W, 0603, AEC-Q200	VISHAY CRCW06031K00JNEA
21	1	R2	RES., 10Ω, 5%, 1/10W, 0603, AEC-Q200	PANASONIC ERJ3GEYJ100V VISHAY CRCW060310R0JNEA
22	1	R3	RES., 20k, 1%, 1/10W, 0603	NIC NRC06F2002TRF VISHAY CRCW060320K0FKEA PANASONIC ERJ3EKF2002V YAGEO RC0603FR-0720KL
23	0	R4	RES., 100Ω, 5%, 5W, 20.47mm × 10.31mm	OHMITE RW5S0FA100RJE
24	2	R5, R6	RES., 100k, 5%, 1/10W, 0603, AEC-Q200	NIC NRC06J104TRF
25	0	R7	RES., OPTION, 0603	
26	1	STNCL1	TOOL, STENCIL, 700-DC3145A	ADI APPROVED SUPPLIER 830-DC3145A
27	1	U1	IC, 15V, 4A MONOLITHIC THERMOELECTRIC COOLER CONTROLLER	ANALOG DEVICES LT8722AV#PBF
28	2	XJP1, XJP2	CONN., SHUNT, FEMALE, 2 POS, 2mm	WURTH ELEKTRONIK 60800213421

SCHEMATIC DIAGRAM

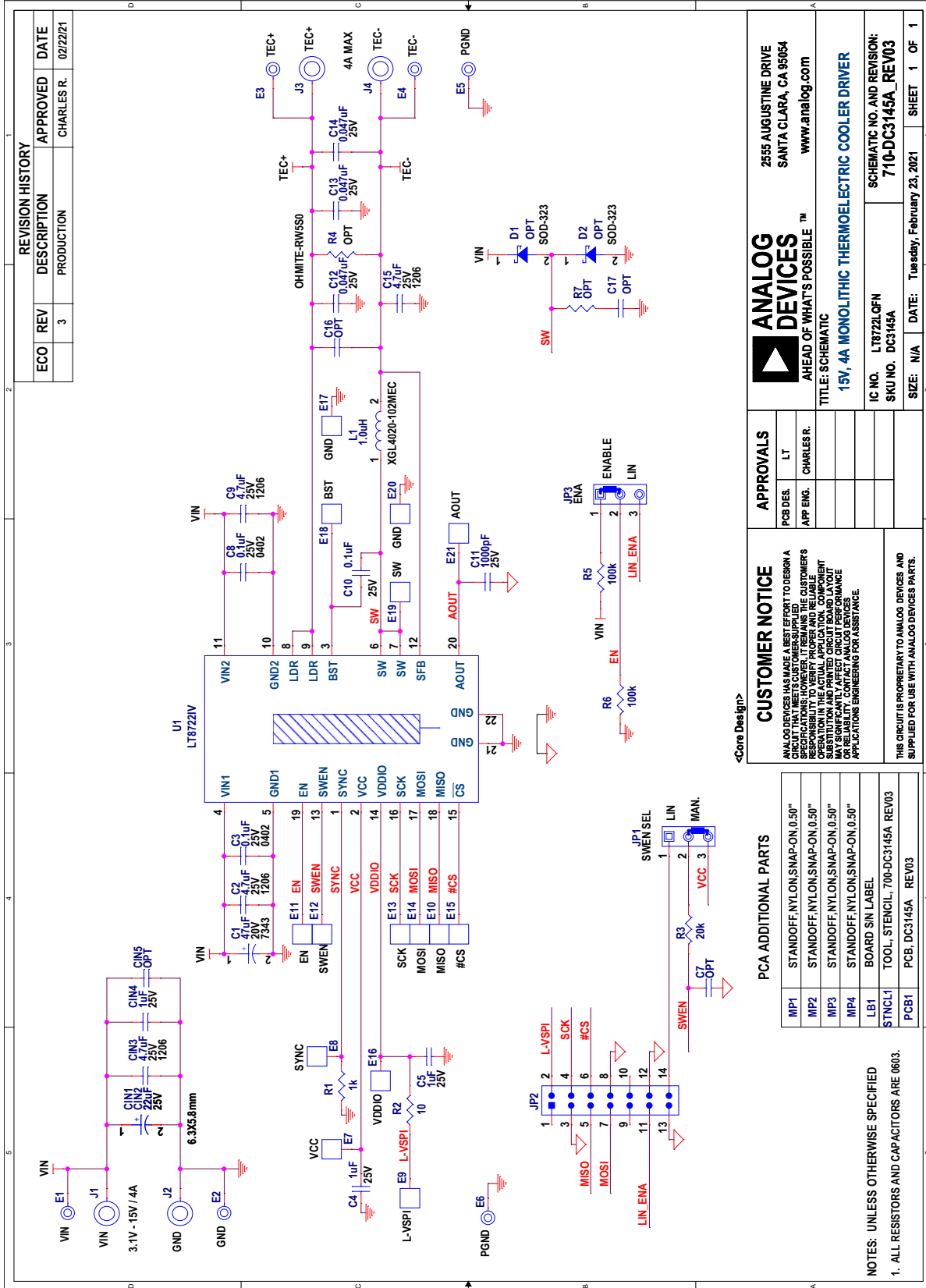

REVISION HISTORY				
ECO	REV	DESCRIPTION	APPROVED	DATE
	3	PRODUCTION	CHARLES R.	02/22/21

		2555 AUGUSTINE DRIVE SANTA CLARA, CA 95054 www.analog.com	
AHEAD OF WHAT'S POSSIBLE™			
TITLE: SCHEMATIC 15V, 4A MONOLITHIC THERMOELECTRIC COOLER DRIVER			
IC NO.	L18722LQFN	SCHEMATIC NO. AND REVISION:	710-DC3145A_REV03
SKU NO.	DC3145A	SIZE:	N/A
DATE:	Tuesday, February 23, 2021	SHEET	1 OF 1

APPROVALS	
PCB DES.	LT
APP ENG.	CHARLES R.

CUSTOMER NOTICE

ANALOG DEVICES HAS MADE A BEST EFFORT TO DESIGN A SPECIFIC ANALOG DEVICE TO MEET THE CUSTOMER'S SPECIFICATIONS. ANALOG DEVICES DOES NOT ASSUME RESPONSIBILITY TO VERIFY PROPER AND RELIABLE OPERATION IN THE ACTUAL APPLICATION. COMPONENTS MAY SIGNIFICANTLY AFFECT CIRCUIT PERFORMANCE OR RELIABILITY. CONTACT ANALOG DEVICES APPLICATIONS ENGINEERING FOR ASSISTANCE.

THIS CIRCUIT IS PROPRIETARY TO ANALOG DEVICES AND SUPPLIED FOR USE WITH ANALOG DEVICES PARTS.

PCA ADDITIONAL PARTS	
MP1	STANDOFF,NYLON,SNAP-ON,0.50"
MP2	STANDOFF,NYLON,SNAP-ON,0.50"
MP3	STANDOFF,NYLON,SNAP-ON,0.50"
MP4	STANDOFF,NYLON,SNAP-ON,0.50"
LB1	BOARD SIN LABEL
STNCL1	TOOL, STENCIL, 700-DC3145A REV03
PCB1	PCB, DC3145A REV03

NOTES: UNLESS OTHERWISE SPECIFIED
 1. ALL RESISTORS AND CAPACITORS ARE 0603.

<Core Design>





ESD Caution

ESD (electrostatic discharge) sensitive device. Charged devices and circuit boards can discharge without detection. Although this product features patented or proprietary protection circuitry, damage may occur on devices subjected to high energy ESD. Therefore, proper ESD precautions should be taken to avoid performance degradation or loss of functionality.

Legal Terms and Conditions

By using the evaluation board discussed herein (together with any tools, components documentation or support materials, the "Evaluation Board"), you are agreeing to be bound by the terms and conditions set forth below ("Agreement") unless you have purchased the Evaluation Board, in which case the Analog Devices Standard Terms and Conditions of Sale shall govern. Do not use the Evaluation Board until you have read and agreed to the Agreement. Your use of the Evaluation Board shall signify your acceptance of the Agreement. This Agreement is made by and between you ("Customer") and Analog Devices, Inc. ("ADI"), with its principal place of business at One Technology Way, Norwood, MA 02062, USA. Subject to the terms and conditions of the Agreement, ADI hereby grants to Customer a free, limited, personal, temporary, non-exclusive, non-sublicensable, non-transferable license to use the Evaluation Board FOR EVALUATION PURPOSES ONLY. Customer understands and agrees that the Evaluation Board is provided for the sole and exclusive purpose referenced above, and agrees not to use the Evaluation Board for any other purpose. Furthermore, the license granted is expressly made subject to the following additional limitations: Customer shall not (i) rent, lease, display, sell, transfer, assign, sublicense, or distribute the Evaluation Board; and (ii) permit any Third Party to access the Evaluation Board. As used herein, the term "Third Party" includes any entity other than ADI, Customer, their employees, affiliates and in-house consultants. The Evaluation Board is NOT sold to Customer; all rights not expressly granted herein, including ownership of the Evaluation Board, are reserved by ADI. CONFIDENTIALITY. This Agreement and the Evaluation Board shall all be considered the confidential and proprietary information of ADI. Customer may not disclose or transfer any portion of the Evaluation Board to any other party for any reason. Upon discontinuation of use of the Evaluation Board or termination of this Agreement, Customer agrees to promptly return the Evaluation Board to ADI. ADDITIONAL RESTRICTIONS. Customer may not disassemble, decompile or reverse engineer chips on the Evaluation Board. Customer shall inform ADI of any occurred damages or any modifications or alterations it makes to the Evaluation Board, including but not limited to soldering or any other activity that affects the material content of the Evaluation Board. Modifications to the Evaluation Board must comply with applicable law, including but not limited to the RoHS Directive. TERMINATION. ADI may terminate this Agreement at any time upon giving written notice to Customer. Customer agrees to return to ADI the Evaluation Board at that time. LIMITATION OF LIABILITY. THE EVALUATION BOARD PROVIDED HEREUNDER IS PROVIDED "AS IS" AND ADI MAKES NO WARRANTIES OR REPRESENTATIONS OF ANY KIND WITH RESPECT TO IT. ADI SPECIFICALLY DISCLAIMS ANY REPRESENTATIONS, ENDORSEMENTS, GUARANTEES, OR WARRANTIES, EXPRESS OR IMPLIED, RELATED TO THE EVALUATION BOARD INCLUDING, BUT NOT LIMITED TO, THE IMPLIED WARRANTY OF MERCHANTABILITY, TITLE, FITNESS FOR A PARTICULAR PURPOSE OR NON-INFRINGEMENT OF INTELLECTUAL PROPERTY RIGHTS. IN NO EVENT WILL ADI AND ITS LICENSORS BE LIABLE FOR ANY INCIDENTAL, SPECIAL, INDIRECT, OR CONSEQUENTIAL DAMAGES RESULTING FROM CUSTOMER'S POSSESSION OR USE OF THE EVALUATION BOARD, INCLUDING BUT NOT LIMITED TO LOST PROFITS, DELAY COSTS, LABOR COSTS OR LOSS OF GOODWILL. ADI'S TOTAL LIABILITY FROM ANY AND ALL CAUSES SHALL BE LIMITED TO THE AMOUNT OF ONE HUNDRED US DOLLARS (\$100.00). EXPORT. Customer agrees that it will not directly or indirectly export the Evaluation Board to another country, and that it will comply with all applicable United States federal laws and regulations relating to exports. GOVERNING LAW. This Agreement shall be governed by and construed in accordance with the substantive laws of the Commonwealth of Massachusetts (excluding conflict of law rules). Any legal action regarding this Agreement will be heard in the state or federal courts having jurisdiction in Suffolk County, Massachusetts, and Customer hereby submits to the personal jurisdiction and venue of such courts. The United Nations Convention on Contracts for the International Sale of Goods shall not apply to this Agreement and is expressly disclaimed.