

Adaptor
RPC-3.50 jack – RPC-N 50 Ω jack

03KR105-K0AS3

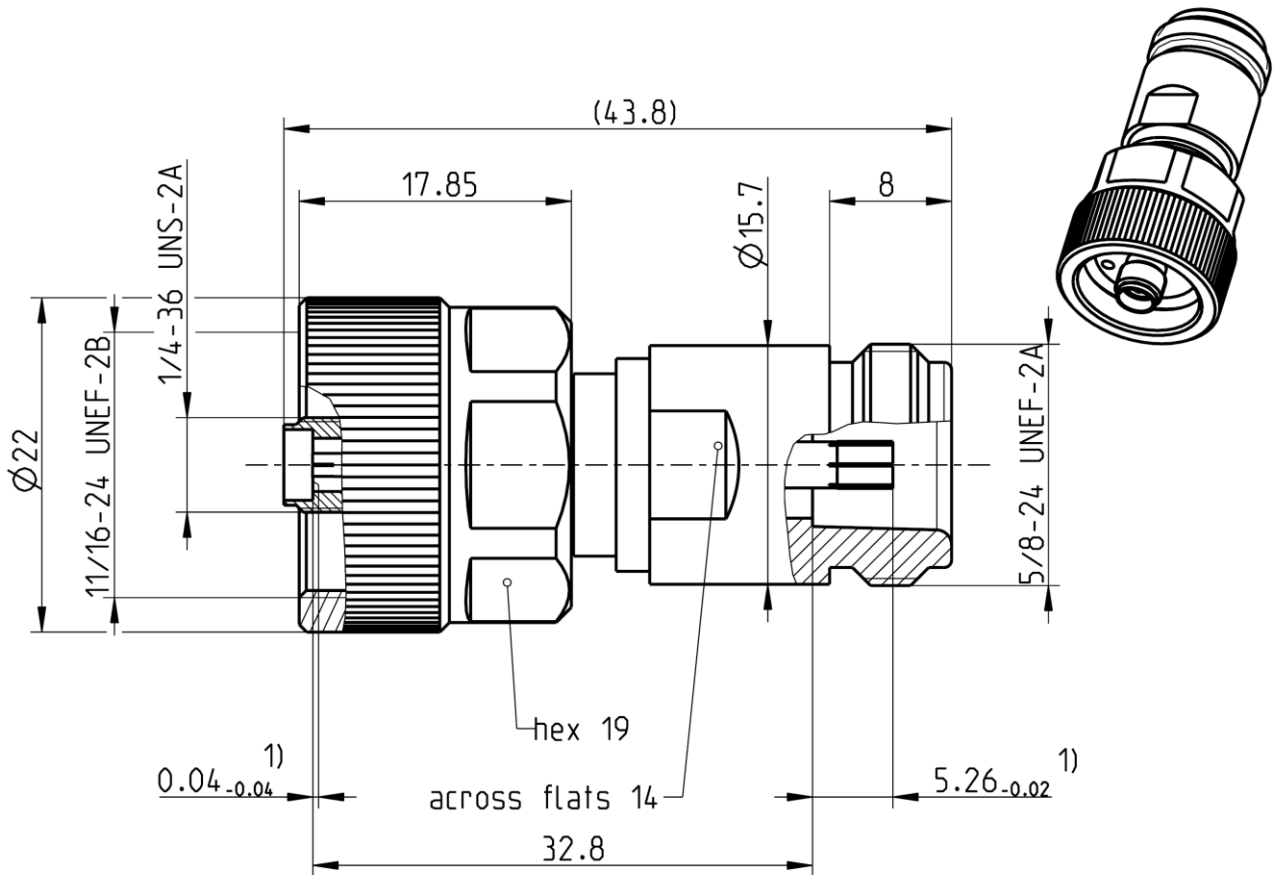

1) restricted connection dimension

All dimensions are in mm; tolerances according to ISO 2768 m-H

Interface

RPC-3.50 according to
RPC-3.50 mechanically compatible with
RPC-N according to

IEC 60169-23
RPC-2.92 and SMA
IEC 61169-16; MIL-STD 348A/402

Documents

N/A

Material and plating

Connector parts

Center contact
Outer contact
Coupling nut
Dielectric

Material

CuBe
Stainless steel
Stainless steel
PPE

Plating

Gold, min. 1.27 μ m, over chemical nickel
Passivated
Passivated

Adaptor
RPC-3.50 jack – RPC-N 50 Ω jack

03KR105-K0AS3

Electrical data

Impedance	50 Ω
Frequency	DC to 18 GHz
Return loss	≥ 26 dB, DC to 18 GHz
Insertion loss	≤ 0.05 x √f(GHz) dB
Insulation resistance	≥ 5 GΩ
Test voltage (at sea level)	1000 V rms
Working voltage (at sea level)	335 V rms
RF-leakage	≥ 90 dB up to 1 GHz

Mechanical data

Mating cycles	≥ 500
Center contact captivation	≥ 28 N
Coupling test torque RPC-3.50	1.70 Nm
Recommended torque RPC-3.50	0.80 Nm to 1.10 Nm
Coupling test torque RPC-N	1.70 Nm
Recommended torque RPC-N	0.70 Nm to 1.10 Nm
Recommended torque ruggedized nut	1.36 Nm

Environmental data

Temperature range	-40°C to +85°C
Thermal shock	MIL-STD-202, Method 107, Condition B
Corrosion	MIL-STD-202, Method 101, Condition B
Vibration	MIL-STD-202, Method 204, Condition D
Shock	MIL-STD-202, Method 213, Condition I
Moisture resistance	MIL-STD-202, Method 106
RoHS	compliant

Tooling

N/A

Suitable cables

N/A

Weight

60.0 g/pce

While the information has been carefully compiled to the best of our knowledge, nothing is intended as representation or warranty on our part and no statement herein shall be construed as recommendation to infringe existing patents. In the effort to improve our products, we reserve the right to make changes judged to be necessary.

Draft	Date	Approved	Date	Rev.	Engineering change number	Name	Date
M. Moder	10.08.10	F. Reiner	02.07.18	a01	18-1026	M. Ruf	29.06.18

Rosenberger Hochfrequenztechnik GmbH & Co. KG
P.O.Box 1260 D-84526 Tittmoning Germany
www.rosenberger.de

Tel. : +49 8684 18-0
Email : info@rosenberger.de

Page

2 / 2