

WIRING DIAGRAM ± 3 CORE CABLE

▽ 2	▽ 3	▽ 4	
MOLEX I/O CONNECTOR	2 CORE CABLE	MOLEX I/O CONNECTOR	
CIRCUIT No.	CONDUCTOR No.	CIRCUIT No.	CONDUCTOR COLOUR REF
1 →	1 →	→ 2	RED
2 →	→ BRAID →	→ 3	
3 →	→ 2 →	→ 4	YELLOW

▽ 3 CABLE SPECIFICATION : 2 CORE CABLE

1. CABLE TYPE: FLAT  RIBBON  ROUND  OTHER   
 SPIRAL CABLE YES  NO   
 NO. OF CONDUCTORS  2

2. CABLE REQUIREMENTS : N/A

3. CONDUCTOR SPECIFICATIONS :

	CONDUCTOR NO.
	1, 2
CONDUCTOR :	
- MATERIAL	TINNED CU
- A.W.G.	28
- STRANDING QTY/GUAGE	7/36
- TENSILE STRENGTH	N/A
INSULATION :	
- MATERIAL	SEMI RIGID PVC
- MIN. WALL THICKNESS	0.20
- COLOUR	SEE CABLE DIAGRAM
- OUTSIDE DIAMETER	0.90 ± 0.05
DIRECTION OF LAY	LEFT HAND
LENGTH OF LAY	30 ± 5.0
U.L. RATING	UL - 1692

COLOURS:  
1. RED  
2. YELLOW

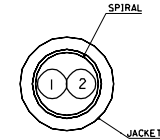

SCALE 10:1

4. FILLER :

N/A

5. SEPARATOR :

N/A

6. SHIELD :

FOIL TYPE N/A  
FOIL FACING N/A

7. DRAIN WIRE :

GAUGE N/A  
STRANDING N/A  
REQUIREMENT N/A

8. SPIRAL/BRAID :

GAUGE 38  
COPPER TYPE TINNED  
COVERAGE 90% MINIMUM

9. CABLE JACKET :

TYPE PVC  
FINAL DIAMETER 2.7 ± 0.15  
MIN. THICKNESS 0.30  
COLOUR GREY  
FINISH GLOSS  
U.L. RATING UL 20276  
HARDNESS 61 ± 3 SHORE A  
STRIPABILITY GOOD  
MARKINGS ED1663-1 RJ 4MM STYLE 2590 28 AWG 80°C VW-1 SC

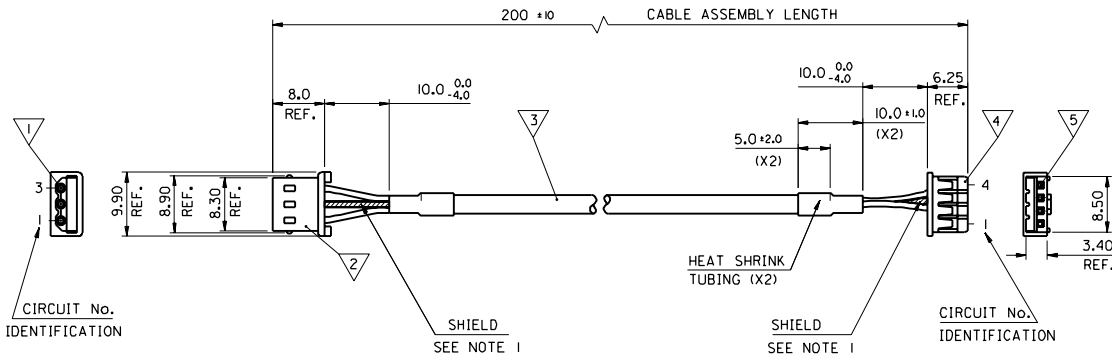

BILL OF MATERIALS

NO.	QTY	SUPPLIER	DESCRIPTION	PART No.	SEE NOTE
▽ 1	3	MOLEX	SPRING-BOX CRIMP TERMINAL	5263PBT	
▽ 2	1	MOLEX	3 CCT SHROUDED CRIMP TERMINAL HOUSING	5264-03	
▽ 3	1	MOLEX	2 CORE CABLE SEE CABLE SPECIFICATION	99036-0095	1, 3
▽ 4	1	MOLEX	4 CIRCUIT CONNECTOR	87369-0400	
▽ 5	3	MOLEX	CRIMP TERMINAL	50212-8000	

NOTES:

1. BRAIDED SHIELD TO BE TWISTED AND COVERED WITH HEAT SHRINK INSULATION TUBING BEFORE CRIMPING.
2. PARTS TO BE CHECKED FOR SHORTS AND CONTINUITIES.
3. ONLY AVAILABLE FROM MOLEX AS PART OF A CABLE ASSEMBLY.
4. SUPPLIER OR CUSTOMER APPROVED EQUIVALENT.
5. PARTS PACKED LOOSELY IN BAGS.

ORIGINAL RELEASE EC No. E80079 DRAWN: D.RYAN 97/0903 CHK: / / / / APPR: / / / /	QUALITY SYMBOLS MAJOR CRITICAL C	GENERAL TOLERANCES: (UNLESS SPECIFIED)	SCALE 2 : 1	DESIGN UNITS <input checked="" type="checkbox"/> mm <input type="checkbox"/> INCH	THIRD ANGLE PROJECTION	DIMENSIONS: <input type="checkbox"/> mm <input type="checkbox"/> INCH <input checked="" type="checkbox"/> mm ONLY	SHT	REV	
		4 PLACES ± 0.1 ± .1 3 PLACES ± 0.1 ± .1 2 PLACES ± 0.1 ± .1 1 PLACE ± 0.1 ± .1 ANGULAR: ± 1/2 °	DRAWN BY & DATE D.RYAN 97/09/03	CHECKED BY & DATE M.CARR 97/09/11	APPROVED BY & DATE M.W. 97/09/11	TITLE: <b>AUDIO CABLE ASSEMBLY</b>			
REV	DESCRIPTION	CAD FILENAME S9260111.DGN	MATERIAL NO. 92601-0011	DRAWING NO. SD-92601-005	MOLEX INCORPORATED		SHEET NO. 1 OF 1	SIZE C	
DRAFT WHERE APPLICABLE MUST REMAIN WITHIN DIMENSIONS		THIS DRAWING CONTAINS INFORMATION THAT IS PROPRIETARY TO MOLEX INCORPORATED AND SHOULD NOT BE USED WITHOUT WRITTEN PERMISSION.							

PART NO. 1100-1-09261  
DWG NO. SD-92601-005