

# RF Power Field Effect Transistors

## N-Channel Enhancement-Mode Lateral MOSFET

Designed for broadband commercial and industrial applications with frequencies from 865 to 895 MHz. The high gain and broadband performance of this device makes it ideal for large-signal, common source amplifier applications in 26 volt base station equipment.

- Typical CDMA Performance @ 880 MHz, 26 Volts,  $I_{DQ} = 1000$  mA  
IS-95 CDMA (Pilot, Sync, Paging, Traffic Codes 8 Through 13)  
Output Power — 26 Watts  
Power Gain — 16 dB  
Efficiency — 26%  
Adjacent Channel Power —  
750 kHz: -45 dBc in 30 kHz BW  
1.98 MHz: -60 dBc in 30 kHz BW
- Capable of Handling 10:1 VSWR, @ 26 Vdc, 880 MHz, 120 Watts CW Output Power

### Features

- Characterized with Series Equivalent Large-Signal Impedance Parameters
- Integrated ESD Protection
- Designed for Maximum Gain and Insertion Phase Flatness
- Excellent Thermal Stability
- Available with Low Gold Plating Thickness on Leads. L Suffix Indicates 40 $\mu$ m Nominal.
- RoHS Compliant
- In Tape and Reel. R3 Suffix = 250 Units per 56 mm, 13 inch Reel.

**MRF9120LR3**

**880 MHz, 120 W, 26 V  
LATERAL N-CHANNEL  
RF POWER MOSFET**

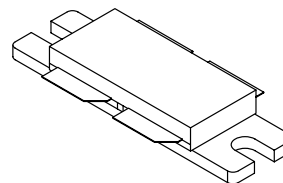

**CASE 375B-04, STYLE 1  
NI-860**

ARCHIVE INFORMATION

ARCHIVE INFORMATION

**Table 1. Maximum Ratings**

Rating	Symbol	Value	Unit
Drain-Source Voltage	$V_{DSS}$	- 0.5, +65	Vdc
Gate-Source Voltage	$V_{GS}$	- 0.5, +15	Vdc
Total Device Dissipation @ $T_C = 25^\circ\text{C}$ Derate above 25 $^\circ\text{C}$	$P_D$	250 1.43	W W/ $^\circ\text{C}$
Storage Temperature Range	$T_{stg}$	- 65 to +150	$^\circ\text{C}$
Case Operating Temperature	$T_C$	150	$^\circ\text{C}$
Operating Junction Temperature	$T_J$	200	$^\circ\text{C}$

**Table 2. Thermal Characteristics**

Characteristic	Symbol	Value	Unit
Thermal Resistance, Junction to Case	$R_{\theta JC}$	0.45	$^\circ\text{C}/\text{W}$

**Table 3. ESD Protection Characteristics**

Test Conditions	Class
Human Body Model	1 (Minimum)
Machine Model	M1 (Minimum)

**Table 4. Electrical Characteristics** ( $T_C = 25^\circ\text{C}$  unless otherwise noted)

Characteristic	Symbol	Min	Typ	Max	Unit
<b>Off Characteristics</b> <sup>(1)</sup>					
Zero Gate Voltage Drain Leakage Current ( $V_{DS} = 65\text{ Vdc}$ , $V_{GS} = 0\text{ Vdc}$ )	$I_{DSS}$	—	—	10	$\mu\text{A}$
Zero Gate Voltage Drain Leakage Current ( $V_{DS} = 26\text{ Vdc}$ , $V_{GS} = 0\text{ Vdc}$ )	$I_{DSS}$	—	—	1	$\mu\text{A}$
Gate-Source Leakage Current ( $V_{GS} = 5\text{ Vdc}$ , $V_{DS} = 0\text{ Vdc}$ )	$I_{GSS}$	—	—	1	$\mu\text{A}$
<b>On Characteristics</b>					
Gate Threshold Voltage <sup>(1)</sup> ( $V_{DS} = 10\text{ Vdc}$ , $I_D = 200\ \mu\text{A}$ )	$V_{GS(th)}$	2	3	4	Vdc
Gate Quiescent Voltage <sup>(2)</sup> ( $V_{DS} = 26\text{ Vdc}$ , $I_D = 1000\text{ mA}$ )	$V_{GS(Q)}$	—	3.8	—	Vdc
Drain-Source On-Voltage <sup>(1)</sup> ( $V_{GS} = 10\text{ Vdc}$ , $I_D = 1.3\text{ A}$ )	$V_{DS(on)}$	—	0.17	0.4	Vdc
<b>Dynamic Characteristics</b> <sup>(1,3)</sup>					
Output Capacitance ( $V_{DS} = 26\text{ Vdc} \pm 30\text{ mV(rms)}$ ac @ 1 MHz, $V_{GS} = 0\text{ Vdc}$ )	$C_{OSS}$	—	50	—	pF
Reverse Transfer Capacitance ( $V_{DS} = 26\text{ Vdc} \pm 30\text{ mV(rms)}$ ac @ 1 MHz, $V_{GS} = 0\text{ Vdc}$ )	$C_{RSS}$	—	2	—	pF

- Each side of device measured separately.
- Measurement made with device in push-pull configuration.
- Part internally input matched.

(continued)

**Table 4. Electrical Characteristics** ( $T_C = 25^\circ\text{C}$  unless otherwise noted) (continued)

Characteristic	Symbol	Min	Typ	Max	Unit
<b>Functional Tests</b> <sup>(1)</sup> (In Freescale Test Fixture, 50 ohm system)					
Two-Tone Common-Source Amplifier Power Gain ( $V_{DD} = 26\text{ Vdc}$ , $P_{out} = 120\text{ W PEP}$ , $I_{DQ} = 1000\text{ mA}$ , $f_1 = 880.0\text{ MHz}$ , $f_2 = 880.1\text{ MHz}$ )	$G_{ps}$	15	16.5	—	dB
Two-Tone Drain Efficiency ( $V_{DD} = 26\text{ Vdc}$ , $P_{out} = 120\text{ W PEP}$ , $I_{DQ} = 1000\text{ mA}$ , $f_1 = 880.0\text{ MHz}$ , $f_2 = 880.1\text{ MHz}$ )	$\eta$	36	39	—	%
3rd Order Intermodulation Distortion ( $V_{DD} = 26\text{ Vdc}$ , $P_{out} = 120\text{ W PEP}$ , $I_{DQ} = 1000\text{ mA}$ , $f_1 = 880.0\text{ MHz}$ , $f_2 = 880.1\text{ MHz}$ )	IMD	—	-31	-28	dBc
Input Return Loss ( $V_{DD} = 26\text{ Vdc}$ , $P_{out} = 120\text{ W PEP}$ , $I_{DQ} = 1000\text{ mA}$ , $f_1 = 880.0\text{ MHz}$ , $f_2 = 880.1\text{ MHz}$ )	IRL	—	-16	-9	dB
Two-Tone Common-Source Amplifier Power Gain ( $V_{DD} = 26\text{ Vdc}$ , $P_{out} = 120\text{ W PEP}$ , $I_{DQ} = 1000\text{ mA}$ , $f_1 = 895.0\text{ MHz}$ , $f_2 = 895.1\text{ MHz}$ )	$G_{ps}$	—	16.5	—	dB
Two-Tone Drain Efficiency ( $V_{DD} = 26\text{ Vdc}$ , $P_{out} = 120\text{ W PEP}$ , $I_{DQ} = 1000\text{ mA}$ , $f_1 = 895.0\text{ MHz}$ , $f_2 = 895.1\text{ MHz}$ )	$\eta$	—	40.5	—	%
3rd Order Intermodulation Distortion ( $V_{DD} = 26\text{ Vdc}$ , $P_{out} = 120\text{ W PEP}$ , $I_{DQ} = 1000\text{ mA}$ , $f_1 = 895.0\text{ MHz}$ , $f_2 = 895.1\text{ MHz}$ )	IMD	—	-30	—	dBc
Input Return Loss ( $V_{DD} = 26\text{ Vdc}$ , $P_{out} = 120\text{ W PEP}$ , $I_{DQ} = 1000\text{ mA}$ , $f_1 = 895.0\text{ MHz}$ , $f_2 = 895.1\text{ MHz}$ )	IRL	—	-13	—	dB
Power Output, 1 dB Compression Point ( $V_{DD} = 26\text{ Vdc}$ , $P_{out} = 120\text{ W CW}$ , $I_{DQ} = 1000\text{ mA}$ , $f_1 = 880.0\text{ MHz}$ )	$P_{1dB}$	—	120	—	W
Common-Source Amplifier Power Gain ( $V_{DD} = 26\text{ Vdc}$ , $P_{out} = 120\text{ W CW}$ , $I_{DQ} = 1000\text{ mA}$ , $f_1 = 880.0\text{ MHz}$ )	$G_{ps}$	—	16	—	dB
Drain Efficiency ( $V_{DD} = 26\text{ Vdc}$ , $P_{out} = 120\text{ W CW}$ , $I_{DQ} = 1000\text{ mA}$ , $f_1 = 880.0\text{ MHz}$ )	$\eta$	—	51	—	%

1. Measurement made with device in push-pull configuration.

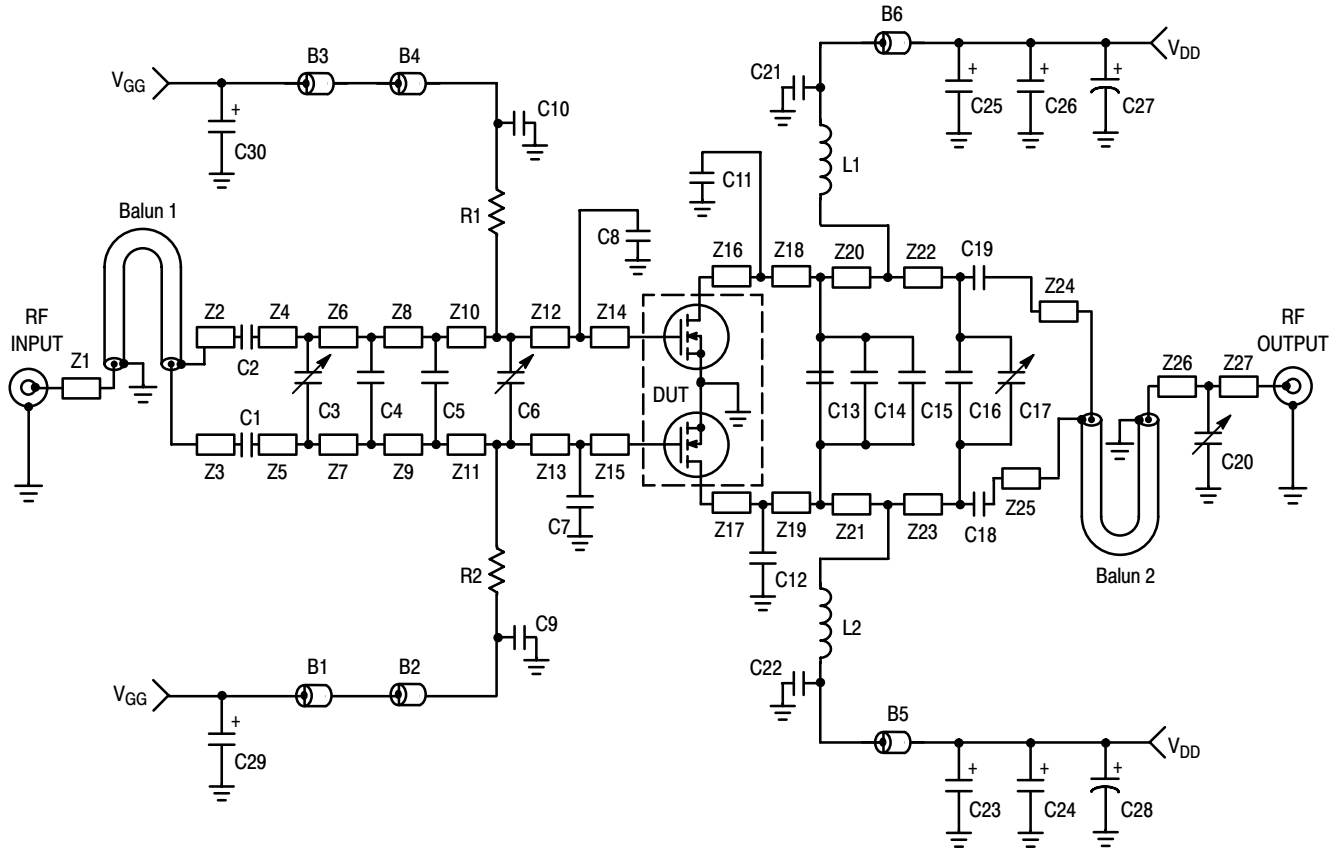

Z1	0.420" x 0.080" Microstrip	Z14, Z15	0.040" x 0.630" Microstrip
Z2, Z3	0.090" x 0.420" Microstrip	Z16, Z17	0.040" x 0.630" Microstrip
Z4, Z5	0.125" x 0.220" Microstrip	Z18, Z19	0.330" x 0.630" Microstrip
Z6, Z7	0.095" x 0.220" Microstrip	Z20, Z21	0.450" x 0.630" Microstrip
Z8, Z9	0.600" x 0.220" Microstrip	Z22, Z23	0.750" x 0.220" Microstrip
Z10, Z11	0.200" x 0.630" Microstrip	Z24, Z25	0.115" x 0.420" Microstrip
Z12, Z13	0.500" x 0.630" Microstrip	Z26	0.130" x 0.080" Microstrip
		Z27	0.350" x 0.080" Microstrip

**Figure 1. 880 MHz Broadband Test Circuit Schematic**

**Table 5. 880 MHz Broadband Test Circuit Component Designations and Values**

Part	Description	Part Number	Manufacturer
B1, B3, B5, B6	Long Ferrite Beads, Surface Mount	95F787	Newark
B2, B4	Short Ferrite Beads, Surface Mount	95F786	Newark
C1, C2	68 pF Chip Capacitors	100B680JP500X	ATC
C3, C6	0.8 - 8.0 pF Variable Capacitors	44F3360	Newark
C4	7.5 pF Chip Capacitor	100B7R5JP150X	ATC
C5	3.3 pF Chip Capacitor	100B3R3CP150X	ATC
C7, C8	11 pF Chip Capacitors	100B110BCA500X	ATC
C9, C10, C21, C22	51 pF Chip Capacitors	100B510JP500X	ATC
C11, C12	6.2 pF Chip Capacitors	100B6R2BCA150X	ATC
C13	4.7 pF Chip Capacitor	100B4R7BCA150X	ATC
C14	5.1 pF Chip Capacitor	100B5R1BCA150X	ATC
C15	3.0 pF Chip Capacitor	100B2R7BCA150X	ATC
C16	2.7 pF Chip Capacitor	100B3R0BCA150X	ATC
C17	0.6 - 4.5 pF Variable Capacitor	44F3358	Newark
C18, C19	47 pF Chip Capacitors	100B470JP500X	ATC
C20	0.4 - 2.5 pF Variable Capacitor	44F3367	Newark
C29, C30	10 $\mu$ F, 35 V Tantalum Chip Capacitors	93F2975	Newark
C23, C24, C25, C26	22 $\mu$ F, 35 V Tantalum Chip Capacitors	92F1853	Newark
C27, C28	220 $\mu$ F, 50 V Electrolytic Capacitors	14F185	Newark
Balun 1, Balun 2	Xinger Surface Mount Balun Transformers	3A412	Anaren
L1, L2	12.5 nH Mini Spring Inductors	A04T-5	Coilcraft
R1, R2	510 $\Omega$ , 1/4 W Chip Resistors		
WB1, WB2, WB3, WB4	10 mil Brass Wear Blocks		
Board Material	30 mil Glass Teflon <sup>®</sup> , $\epsilon_r = 2.55$ Copper Clad, 2 oz Cu	900 MHz Push-Pull Rev 01B	CMR
PCB	Etched Circuit Board	900 MHz Push-Pull Rev 01B	CMR

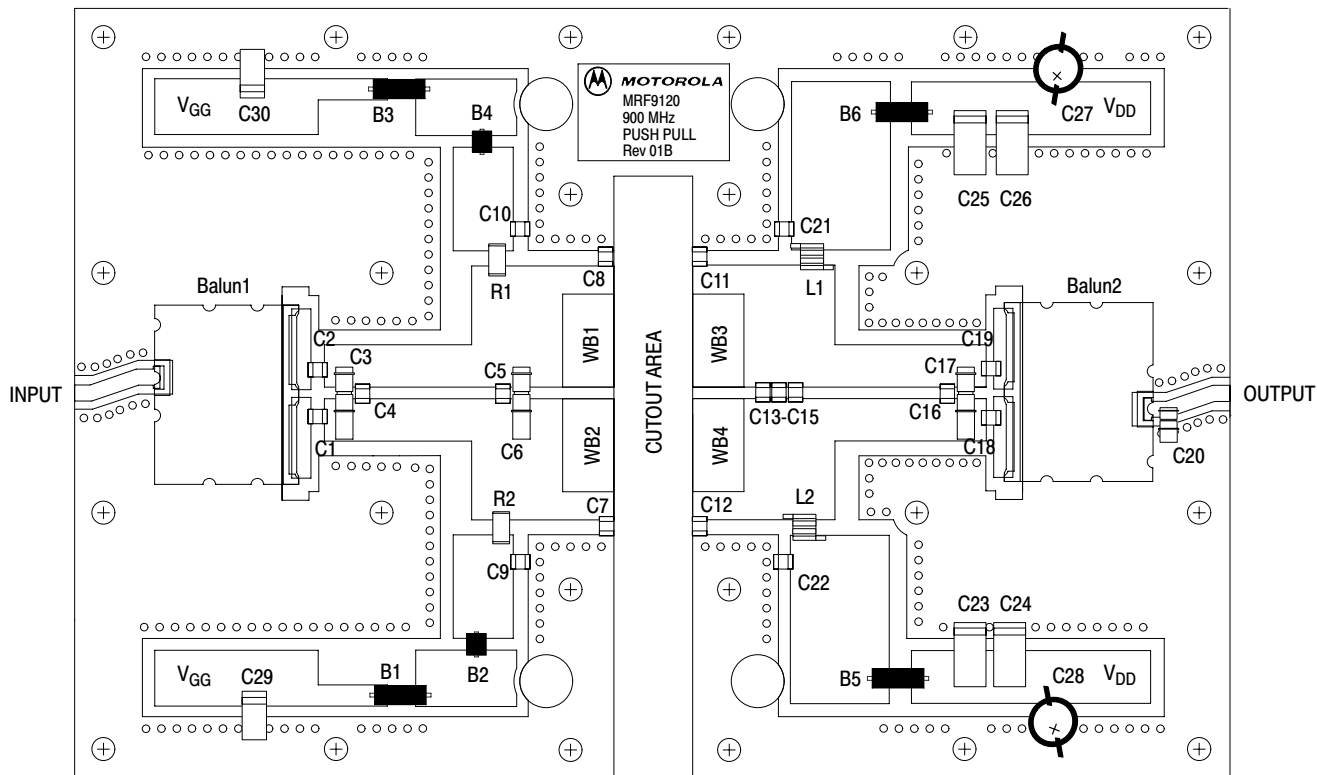

Freescale has begun the transition of marking Printed Circuit Boards (PCBs) with the Freescale Semiconductor signature/logo. PCBs may have either Motorola or Freescale markings during the transition period. These changes will have no impact on form, fit or function of the current product.

**Figure 2. 865-895 MHz Broadband Test Circuit Component Layout**

ARCHIVE INFORMATION

ARCHIVE INFORMATION

### TYPICAL CHARACTERISTICS

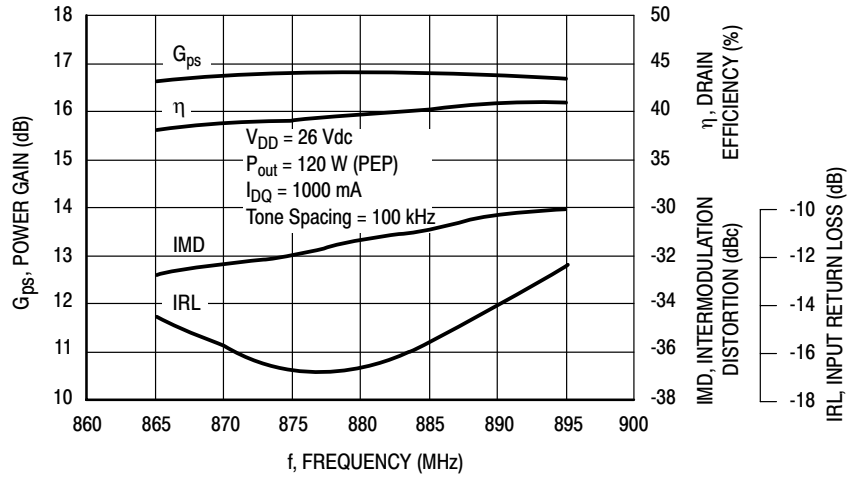

Figure 3. Class AB Broadband Circuit Performance

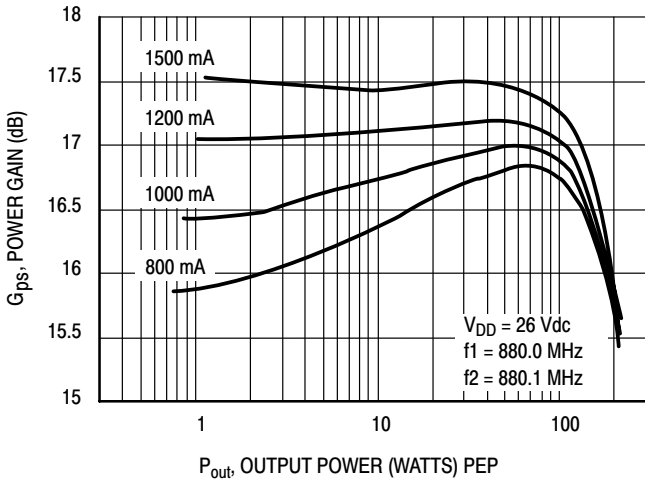

Figure 4. Power Gain versus Output Power

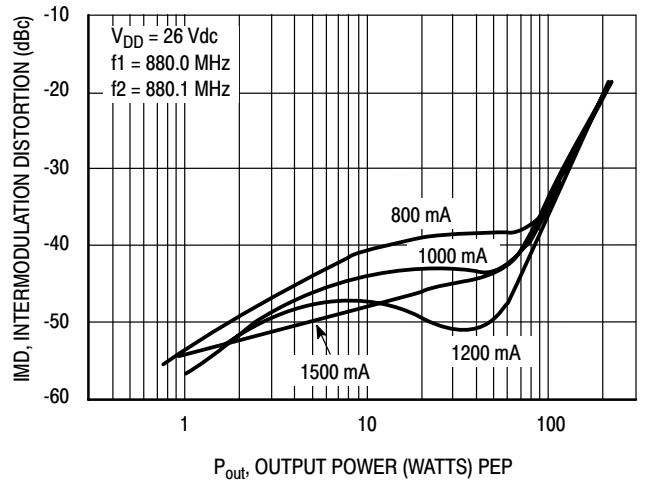

Figure 5. Intermodulation Distortion versus Output Power

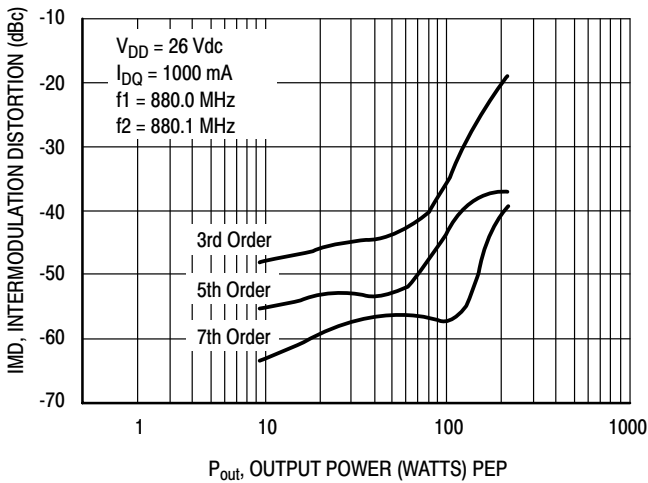

Figure 6. Intermodulation Distortion Products versus Output Power

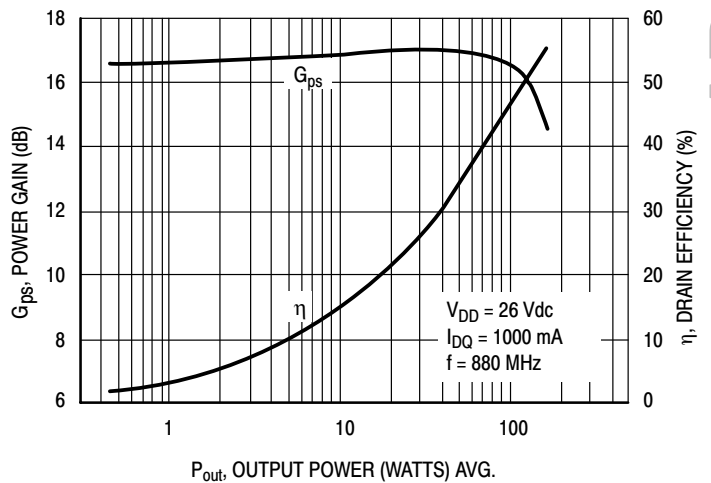
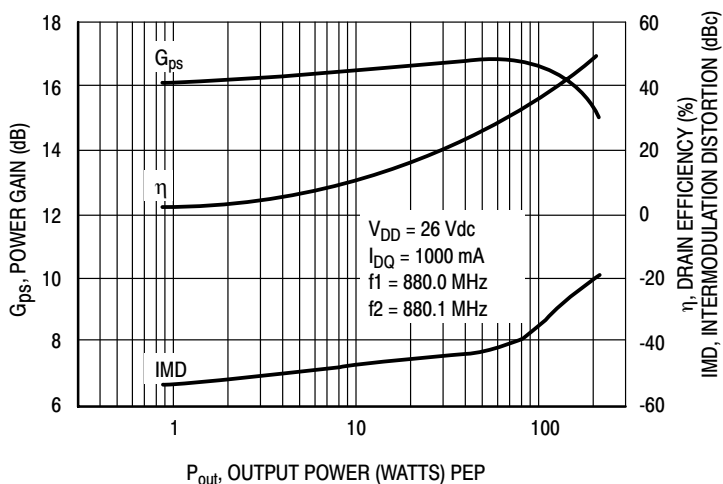

Figure 7. Power Gain and Efficiency versus Output Power

ARCHIVE INFORMATION

ARCHIVE INFORMATION

### TYPICAL CHARACTERISTICS



**Figure 8. Power Gain, Efficiency and IMD versus Output Power**

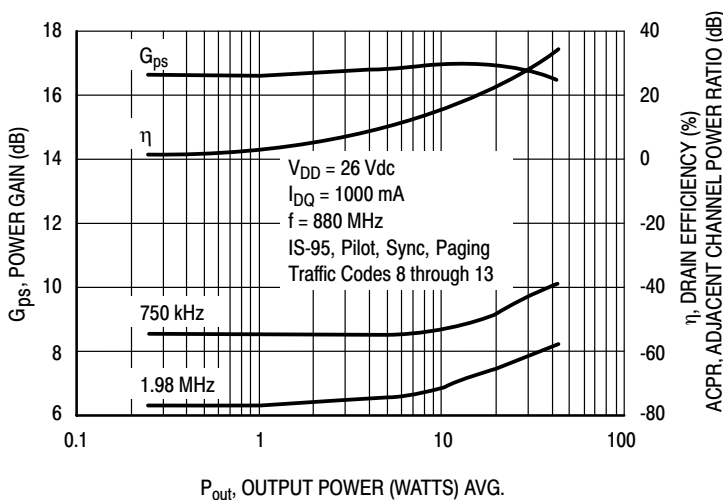
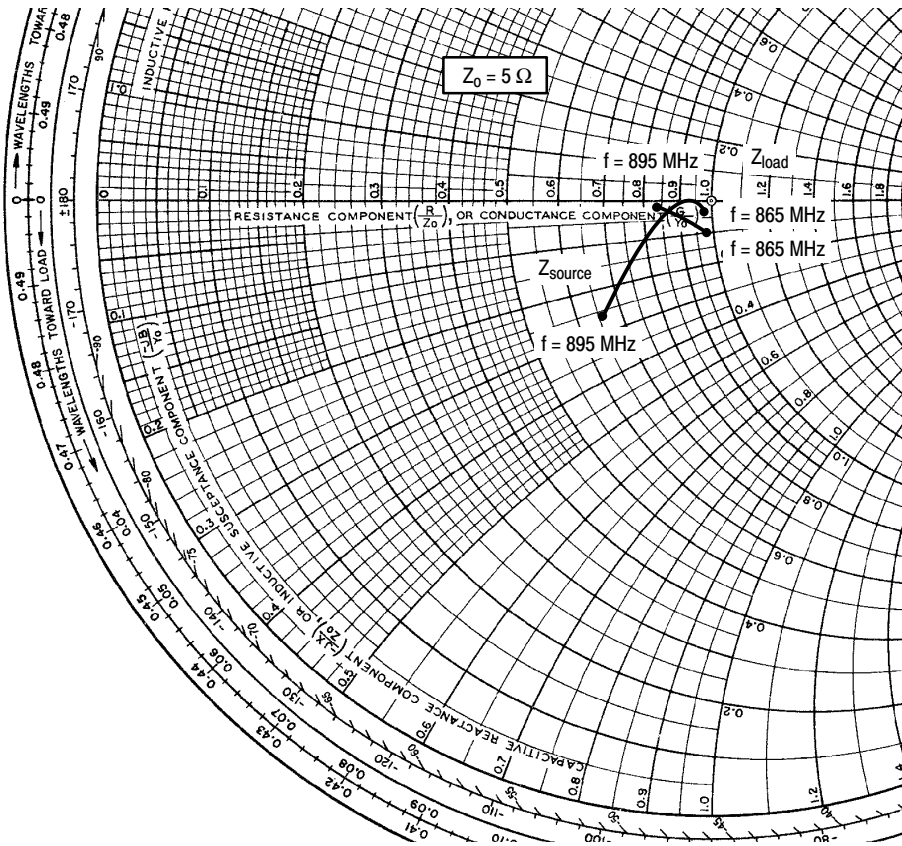

**Figure 9. Power Gain, Efficiency and ACPR versus Output Power**

ARCHIVE INFORMATION

ARCHIVE INFORMATION





$V_{DD} = 26\text{ V}$ ,  $I_{DQ} = 1000\text{ mA}$ ,  $P_{out} = 120\text{ W PEP}$

f MHz	$Z_{source}$ $\Omega$	$Z_{load}$ $\Omega$
865	$4.89 - j0.2$	$4.9 - j0.5$
880	$4.54 + j0.07$	$4.6 - j0.32$
895	$3.29 - j1.3$	$4.2 - j0.04$

$Z_{source}$  = Test circuit impedance as measured from gate to gate, balanced configuration.

$Z_{load}$  = Test circuit impedance as measured from drain to drain, balanced configuration.

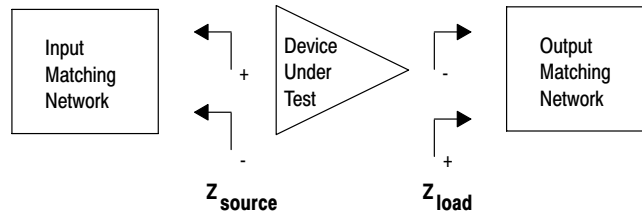
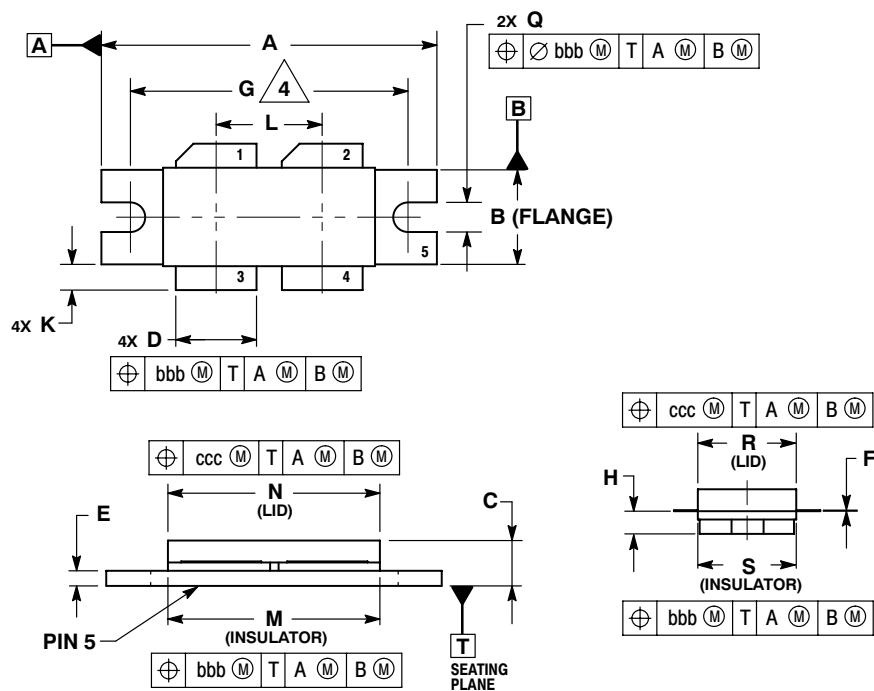

Figure 10. Series Equivalent Source and Load Impedance

### PACKAGE DIMENSIONS



- NOTES:
1. INTERPRET DIMENSIONS AND TOLERANCES PER ASME Y14.5M-1994.
  2. CONTROLLING DIMENSION: INCH.
  3. DIMENSION H IS MEASURED 0.030 (0.762) AWAY FROM PACKAGE BODY.
  4.  $\triangle$  RECOMMENDED BOLT CENTER DIMENSION OF 1.140 (28.96) BASED ON M3 SCREW.

DIM	INCHES		MILLIMETERS	
	MIN	MAX	MIN	MAX
A	1.335	1.345	33.91	34.16
B	0.380	0.390	9.65	9.91
C	0.180	0.224	4.57	5.69
D	0.325	0.335	8.26	8.51
E	0.060	0.070	1.52	1.78
F	0.004	0.006	0.10	0.15
G	1.100 BSC		27.94 BSC	
H	0.097	0.107	2.46	2.72
K	0.085	0.115	2.16	2.92
L	0.425 BSC		10.80 BSC	
M	0.852	0.868	21.64	22.05
N	0.851	0.869	21.62	22.07
Q	0.118	0.138	3.00	3.51
R	0.395	0.405	10.03	10.29
S	0.394	0.406	10.01	10.31
bbb	0.010 REF		0.25 REF	
ccc	0.015 REF		0.38 REF	

- STYLE 1:
1. DRAIN
  2. DRAIN
  3. GATE
  4. GATE
  5. SOURCE

CASE 375B-04  
 ISSUE F  
 NI-860

## REVISION HISTORY

The following table summarizes revisions to this document.

Revision	Date	Description
10	Dec. 2009	<ul style="list-style-type: none"> <li>• Data sheet archived. Part no longer manufactured.</li> </ul>

ARCHIVE INFORMATION

ARCHIVE INFORMATION

**How to Reach Us:**

**Home Page:**  
www.freescale.com

**E-mail:**  
support@freescale.com

**USA/Europe or Locations Not Listed:**  
Freescale Semiconductor  
Technical Information Center, CH370  
1300 N. Alma School Road  
Chandler, Arizona 85224  
+1-800-521-6274 or +1-480-768-2130  
support@freescale.com

**Europe, Middle East, and Africa:**  
Freescale Halbleiter Deutschland GmbH  
Technical Information Center  
Schatzbogen 7  
81829 Muenchen, Germany  
+44 1296 380 456 (English)  
+46 8 52200080 (English)  
+49 89 92103 559 (German)  
+33 1 69 35 48 48 (French)  
support@freescale.com

**Japan:**  
Freescale Semiconductor Japan Ltd.  
Headquarters  
ARCO Tower 15F  
1-8-1, Shimo-Meguro, Meguro-ku,  
Tokyo 153-0064  
Japan  
0120 191014 or +81 3 5437 9125  
support.japan@freescale.com

**Asia/Pacific:**  
Freescale Semiconductor Hong Kong Ltd.  
Technical Information Center  
2 Dai King Street  
Tai Po Industrial Estate  
Tai Po, N.T., Hong Kong  
+800 2666 8080  
support.asia@freescale.com

**For Literature Requests Only:**  
Freescale Semiconductor Literature Distribution Center  
P.O. Box 5405  
Denver, Colorado 80217  
1-800-441-2447 or 303-675-2140  
Fax: 303-675-2150  
LDCForFreescaleSemiconductor@hibbertgroup.com

Information in this document is provided solely to enable system and software implementers to use Freescale Semiconductor products. There are no express or implied copyright licenses granted hereunder to design or fabricate any integrated circuits or integrated circuits based on the information in this document.

Freescale Semiconductor reserves the right to make changes without further notice to any products herein. Freescale Semiconductor makes no warranty, representation or guarantee regarding the suitability of its products for any particular purpose, nor does Freescale Semiconductor assume any liability arising out of the application or use of any product or circuit, and specifically disclaims any and all liability, including without limitation consequential or incidental damages. "Typical" parameters that may be provided in Freescale Semiconductor data sheets and/or specifications can and do vary in different applications and actual performance may vary over time. All operating parameters, including "Typicals", must be validated for each customer application by customer's technical experts. Freescale Semiconductor does not convey any license under its patent rights nor the rights of others. Freescale Semiconductor products are not designed, intended, or authorized for use as components in systems intended for surgical implant into the body, or other applications intended to support or sustain life, or for any other application in which the failure of the Freescale Semiconductor product could create a situation where personal injury or death may occur. Should Buyer purchase or use Freescale Semiconductor products for any such unintended or unauthorized application, Buyer shall indemnify and hold Freescale Semiconductor and its officers, employees, subsidiaries, affiliates, and distributors harmless against all claims, costs, damages, and expenses, and reasonable attorney fees arising out of, directly or indirectly, any claim of personal injury or death associated with such unintended or unauthorized use, even if such claim alleges that Freescale Semiconductor was negligent regarding the design or manufacture of the part.

Freescale™ and the Freescale logo are trademarks of Freescale Semiconductor, Inc. All other product or service names are the property of their respective owners.  
© Freescale Semiconductor, Inc. 2006, 2009. All rights reserved.