

LOC		DIST		REVISIONS			
P	LTR	DESCRIPTION	DATE	DN	APVD		
W		REVISED PER ECO-15-016251	13NOV15	KG	CD		

- THIS PLUG WILL MATE WITH ANY 21C1, SIZE 3 RECEPTACLE IN AMPLIMITE SERIES.
- MAXIMUM WIRE INSULATION TO BE USED WITH THIS PLUG IS $\phi.068$.
- THIS CONNECTOR ACCEPTS (1) POWER 8, OR COAX PIN CONTACT IN POSITION A1, PURCHASED SEPARATELY.
- THIS CONNECTOR ACCEPTS SIZE 20 PIN SIGNAL CONTACTS IN POSITIONS 1 THRU 20, PURCHASED SEPARATELY.

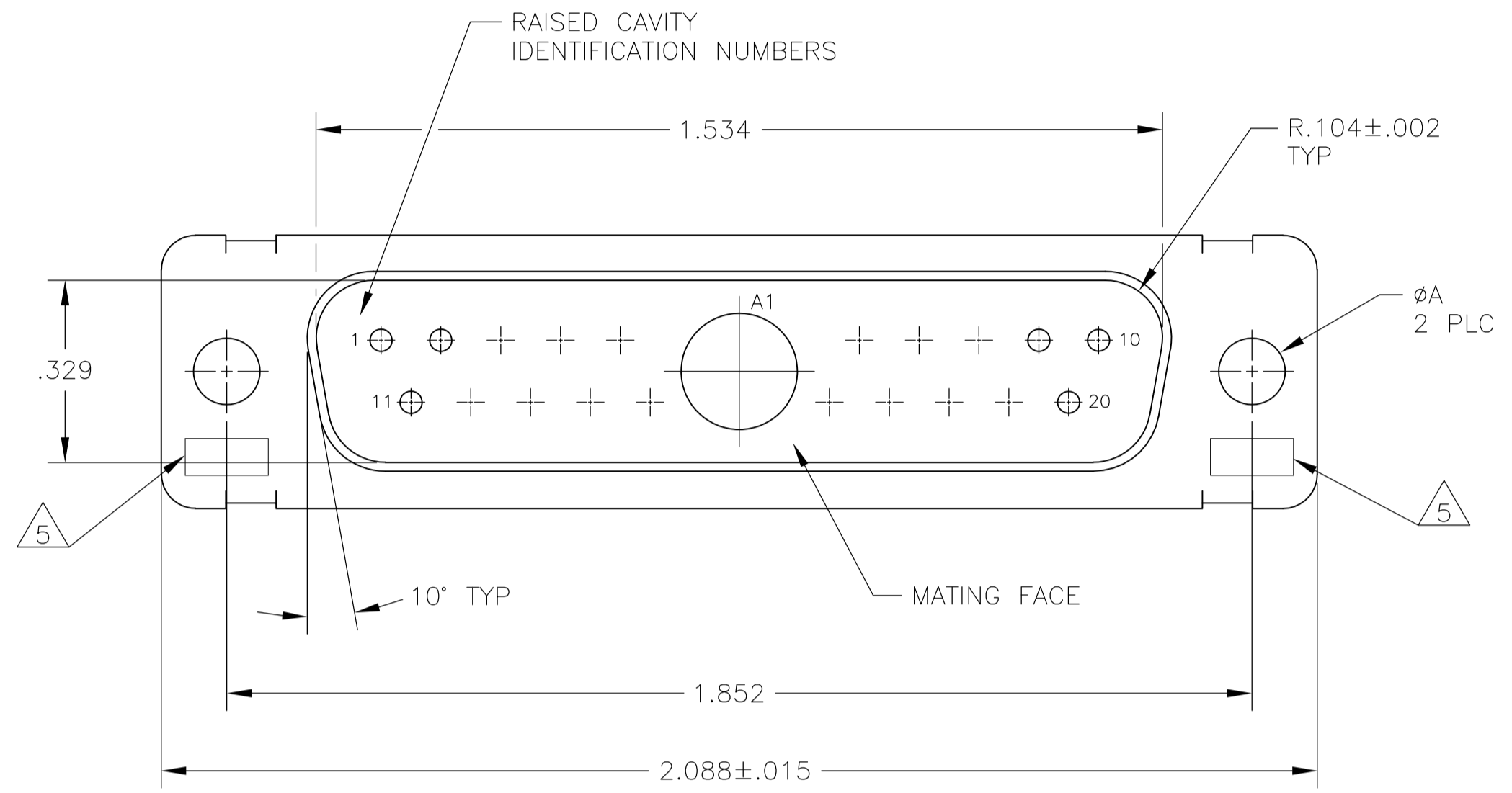

- 5 UL/CSA DESIGNATION STAMPED IN THIS AREA, OPTIONAL.
- 6 STEEL PER ASTM-A-109.
- 7 BRASS PER MIL-C-50 AND ASTM-B-36 UNS NO. C26000.
- 8 CADMIUM PLATED PER QQ-P-416.
- 9 FINISH: GOLD PLATED PER MIL-G-45204 TYPE II, GRADE C, CLASS 1 OVER COPPER PER MIL-C-14550, CLASS IV.
- 10 FINISH: TIN PER ASTM-B-545, .000400 MIN THK OVER COPPER PER AMS2418, .000050 MIN THK
- 11 212552-7 IS OBSOLETE.
- 12 FINISH: ZINC PLATE PER ASTM-B-633 .000200-.000400 THK WITH SUPPLEMENTARY CHROMATE (Cr3+).

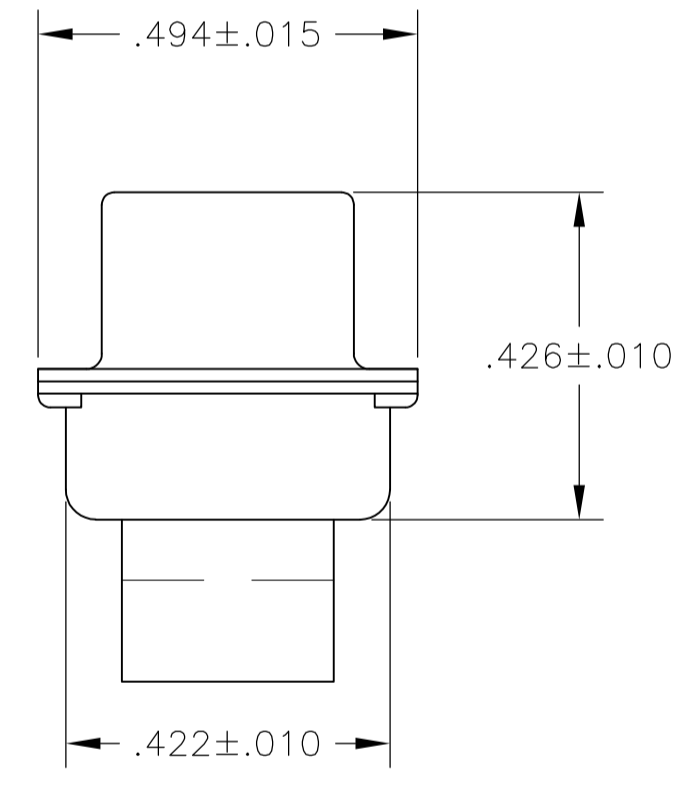
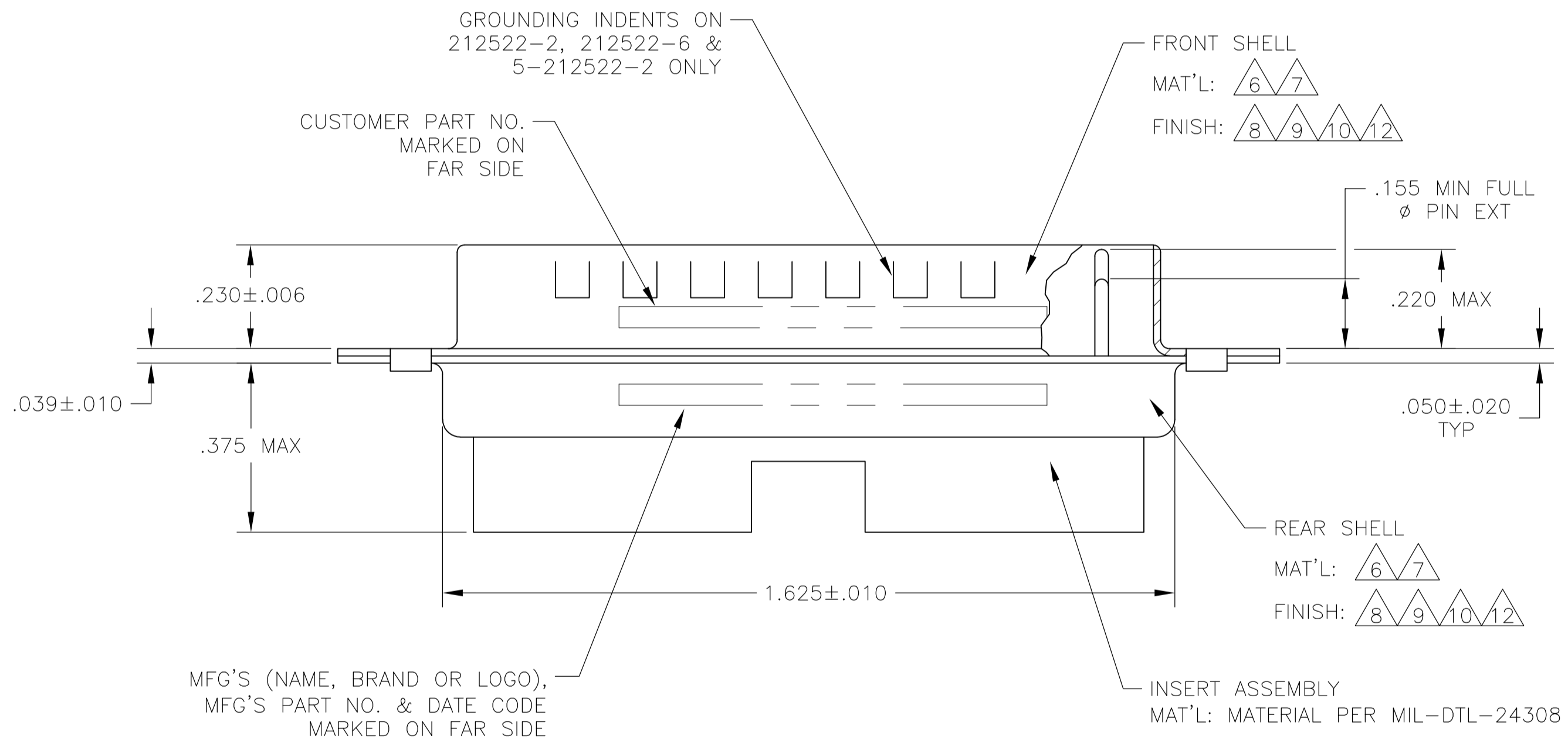

6/10	.120	-	5-212522-2
6/12	.120	-	5-212522-1
6/10	.120	-	212522-7
6/10	.120	-	212522-6
7/9	.120	B010942-0039	212522-5
7/9	.154	311P405-14P-B-15	212522-4
7/9	.120	311P405-14P-B-12	212522-3
6/10	.120	-	212522-2
6/8	.120	-	212522-1
REMARKS	ØA	CUSTOMER P/N	PART NO.

THIS DRAWING IS A CONTROLLED DOCUMENT.

MANJUNATH G. M. 27-May-15
 CHARLES THOMAS 27-May-15
 CHARLES THOMAS 27-May-15

STE TE Connectivity

PLUG ASSEMBLY
 AMPLIMITE 21C1
 SIZE 3, SERIES 109, COAX MIX

SIZE: A1 CAGE CODE: 00779 DRAWING NO: 212522
 WEIGHT: -

CUSTOMER DRAWING SCALE: 4:1 SHEET: 1 OF 1 REV: W