

UNIT: mm

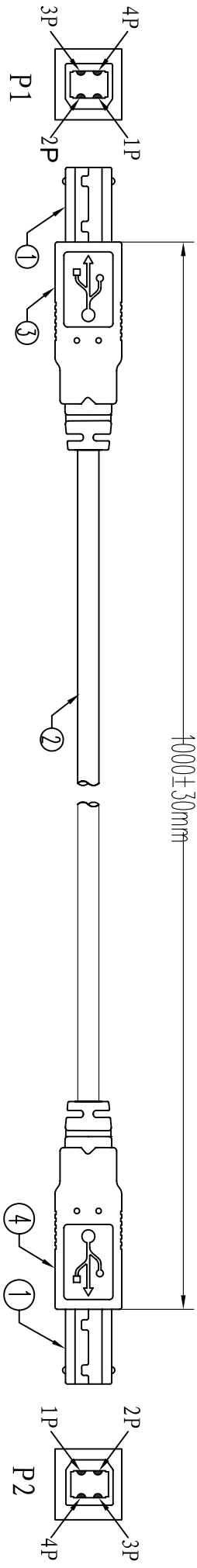

CABLE BLACK PRINT
 USB CABLE E189529
 24AWG/2C 80°C 30V VW-1
 AWM 2725 28AWG/1PR AND

PIN ASSIGNMENT:

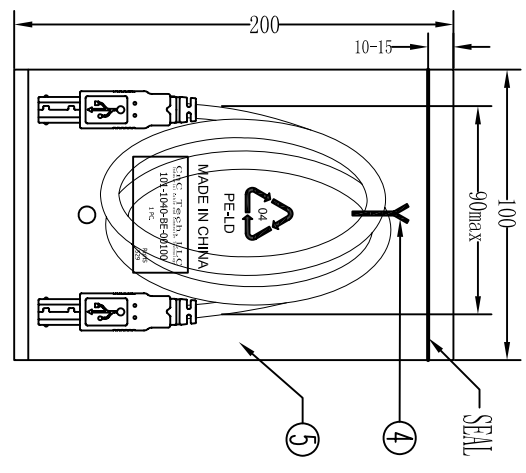
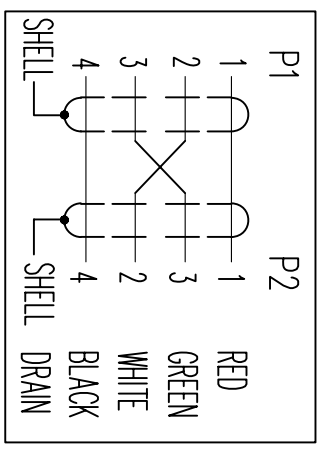

IPC/PE BAG

Electrical test:
 1. 100% short, open, miswire test
 2. Conduct resistance: 2 Ohm(max)
 3. Insulation resistance: 5Mohm(min)
 4. dielectric test: DC 300V

⑥	PE BAG	1/10	CLEAR SIZE:230*300*0.05mm	PRINT BLACK	MADE IN CHINA	"10PCS"
⑤	PE BAG	1	CLEAR SIZE:100*200*0.05mm	PRINT BLACK	MADE IN CHINA	"1PC"
④	TIE	1	WHITE	L=100mm		
③	OUT JACKET	12g	BEIGE(V-29#)	PVC-40P (MOULD NO:WM-65)		
②	CABLE	1	BEIGE(V-29#)	USB2.0 UL2725 28#/1P+24#/2C+AEB	OD:4.7mm	L=1000±10MM
①	CONN	2	USB2.0 B MALE	NICKEL PIN G/F 3PCS	TYPE INSULATOR	COLOR:WHITE

SPECIFICATION

CNC Tech, LLC
 Industrial Cable and Connector Technology

DRAWN	ZHONGHS	DRAWING NO	
CHECKED		CUSTOMER	
APPROVAL		ITEM NO.	101-1040-BE-00100
DECIDED		DATE	2012-02-16
VERSIONS/EDITION	A/0	PROJECTION	