

REVISIONS					
P	LTR	DESCRIPTION	DATE	DMN	APVD
U		REV PER ECO 19-000543	2-18-19	CT	DM

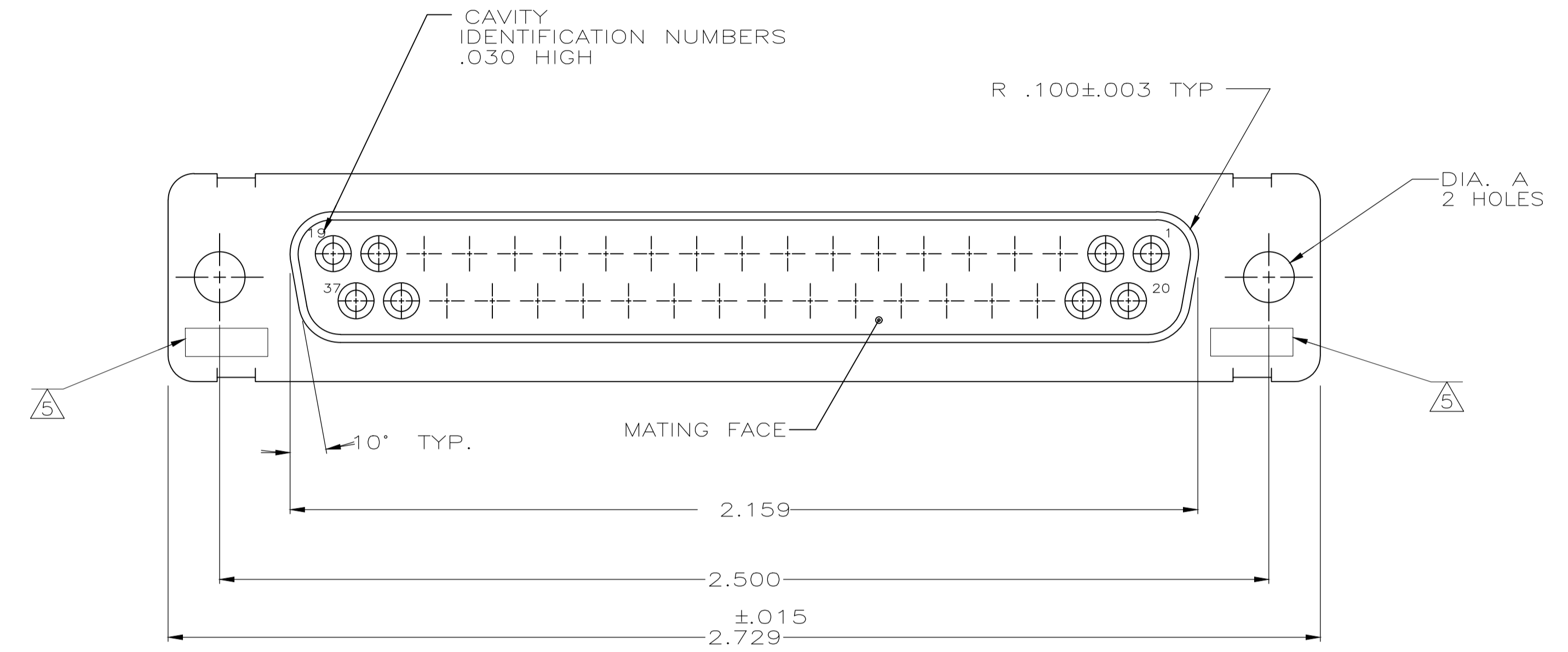

1. THIS RECEPTACLE WILL MATE WITH ANY PLUG CONNECTOR WITH THE SAME INSERT ARRANGEMENT AS DEFINED BY MS18276-1.
 2. MAXIMUM WIRE INSULATION USED WITH THIS RCPT. IS .072 DIA. MAX.
 3. Be-Cu RETENTION CLIPS ARE INCLUDED IN INSERTS.
- Ⓐ FAR SIDE REFERS TO WIDE SIDE OF KEYSTONE.
 - Ⓑ UL/CSA DESIGNATION STAMPED IN THIS AREA, OPTIONAL RESTRICTED TO CAE ELECTRONICS ONLY.
 - Ⓒ THESE CONNECTORS ARE QUALIFIED TO GODDARD SPACE FLIGHT CENTER SPECIFICATION S-311-P-4.
 - Ⓓ CONNECTOR SUPPLIED WITH CONTACTS, AMP PART NUMBER 206793-1; (NOT INSTALLED).

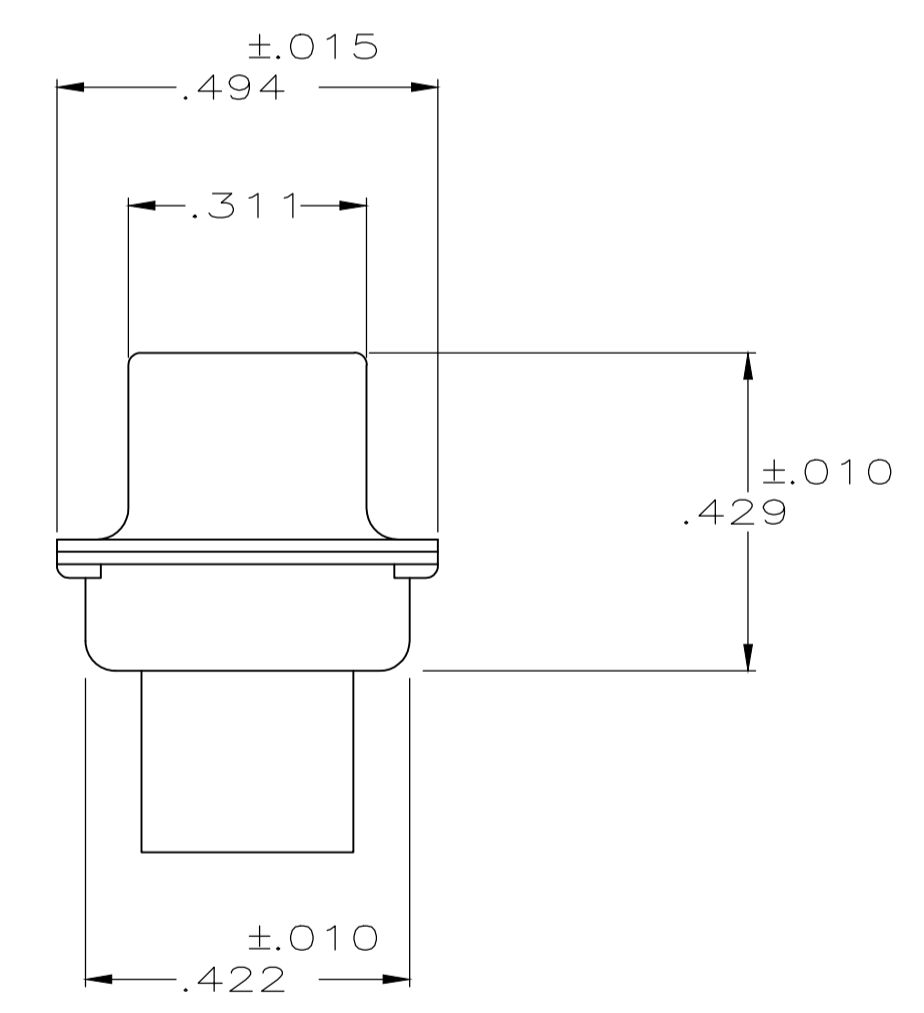
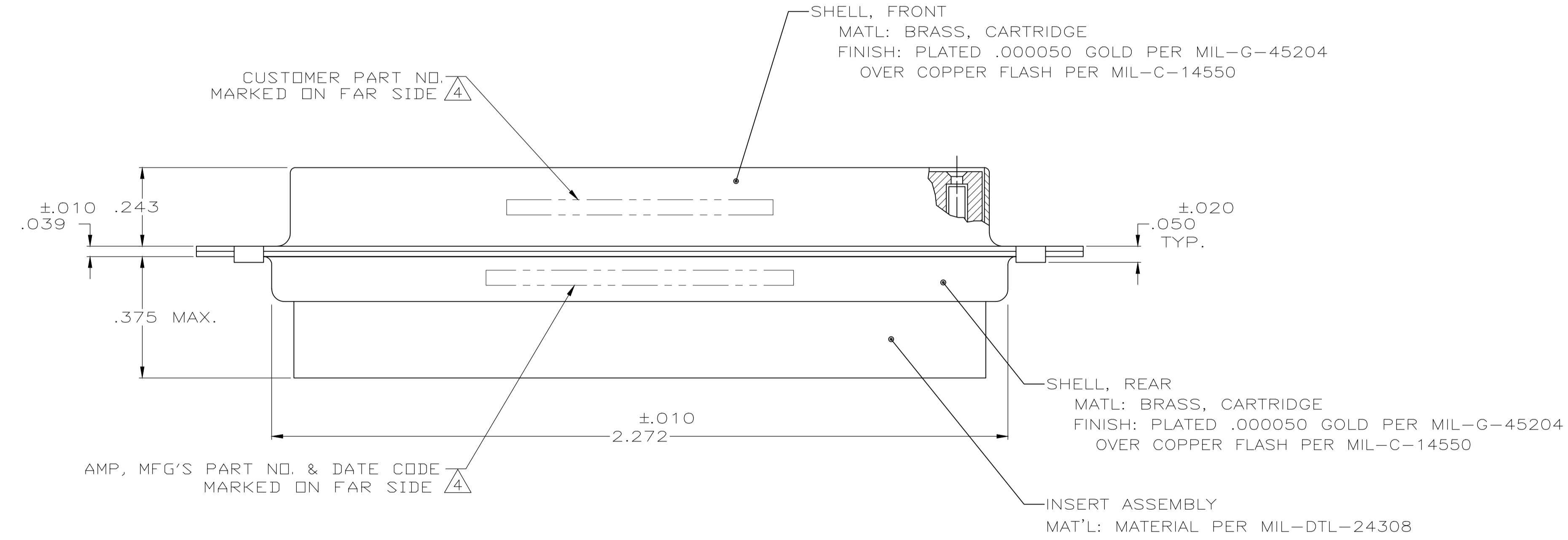

	Ⓓ	.120	570513-4	206803-9
	Ⓓ	.120	LMSC 1621480-004	206803-8
	Ⓓ	.120	LMSC 1621480-004	206803-7
	Ⓓ	.120	311P409-4S-B-12	206803-6
OBSOLETE		.120	2A014-009V-001	206803-4
		.154		206803-3
	Ⓒ	.120	311P409-4S-B-12	206803-2
	Ⓒ	.154	311P409-4S-B-15	206803-1
REMARKS		DIA A	INK STAMPED CUSTOMER P/N	INK STAMPED AMP P/N

THIS DRAWING IS A CONTROLLED DOCUMENT.

MANJUNATH G.M. 27-May-15
 CHARLES THOMAS 27-May-15
 CHARLES THOMAS 27-May-15

STE TE Connectivity

RECEPTACLE FOR SOCKET CONTACT, SIZE 4, 37 POS. (NON-MAGNETIC)

APPROVALS: DIMENSIONS IN INCHES, TOLERANCES UNLESS OTHERWISE SPECIFIED: 0 PLC ±, 1 PLC ±, 2 PLC ±, 3 PLC ±.005, 4 PLC ±, ANGLES ±.

MATERIAL: SEE CALLOUTS. FINISH: SEE CALLOUTS. WEIGHT: 0.000000. SIZE: A1. CAGE CODE: 00779. DRAWING NO: 206803. CUSTOMER DRAWING. SCALE: 4:1. SHEET: 1 OF 1. REV: U.