

LOC		DIST		REVISIONS			
P	LTN	DESCRIPTION	DATE	DMN	APVD		
A1		ECR-12-010297	29JUN2012	C.J.	R.P.		
A2		ECR-21-102131	19APR2021	LZ	FL		
A4		ECR-21-108679	05AUG2021	LZ	FL		

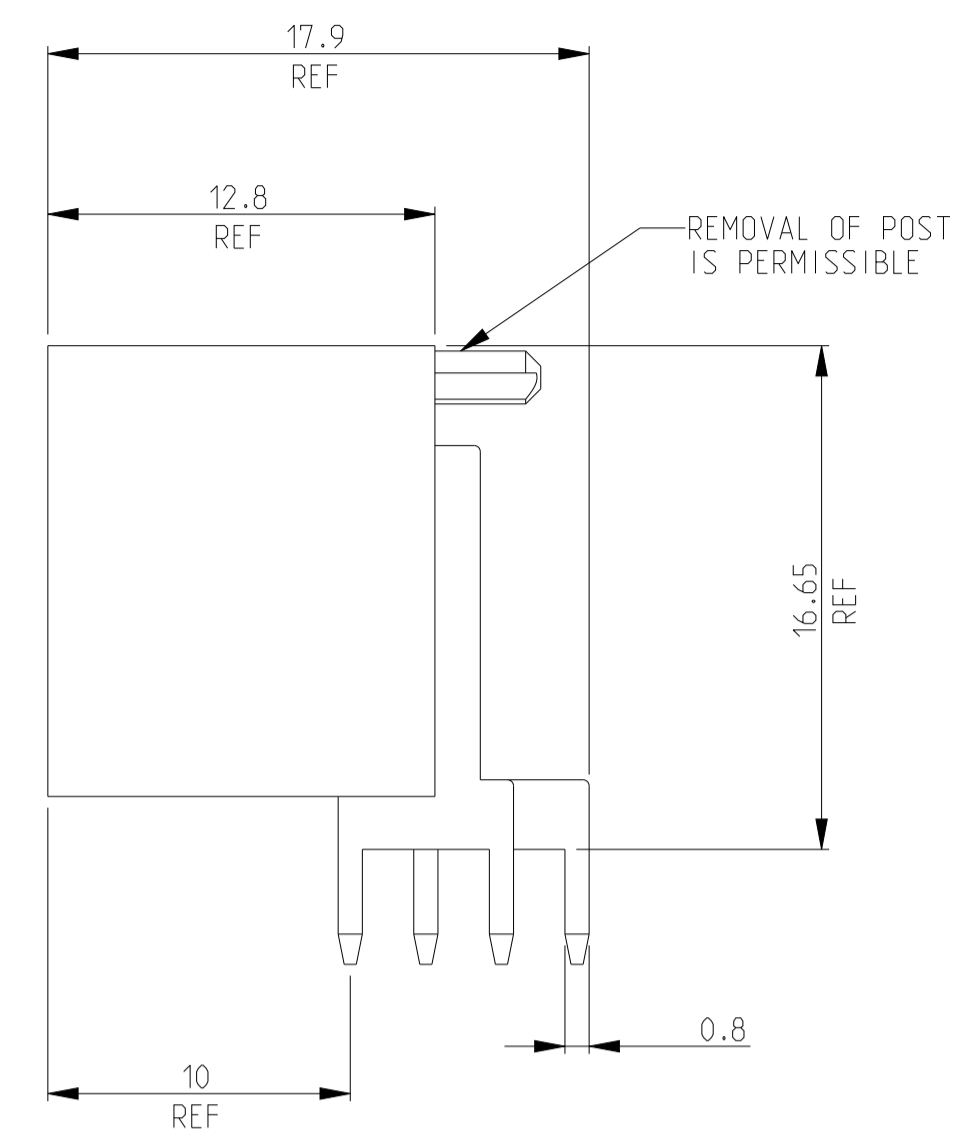

- HOUSING HAS RAST 5 COMPLIANT KEYING, LATCHING, AND POLARIZATION. TAB IS 6.3 x 0.8 (1.250 x .032) ACCORDING TO DIN 46244.
- POSSIBLE MATING CONNECTOR FAMILIES INCLUDE STANDARD TIMER RAST 5, MULTIFITTING, MULTIFITTING MK11, AND MONO-SHAPE TAB CONNECTORS.
- SEE SHEET 2 FOR AVAILABLE CONFIGURATIONS.
- MATERIAL: HOUSING, PA6 NYLON, UL 94V-2. CONTACT, BRASS, 0.8 mm THICK.
- FINISH: CONTACTS, 3.8 μm MIN TIN OVER 1.3 μm MIN NICKEL.
- PCB TABS INSERTED IN A STAGGERED PATTERN BEGINNING WITH POSITION 1.
- SELECTED HOLES MAY BE 1.05+0.05/-0.00 DIA (1.041+.002/-0.001 DIA) FOR IMPROVED (PRESS-FIT) RETENTION TO P.C.B. PRIOR TO SOLDERING.
- DATUM AND BASIC DIMENSION ESTABLISHED BY CUSTOMER
- PRODUCT QUALIFICATION PER 108-2183
- GW T (GLOW WIRE TEST) 750°C WITHOUT FLAME. NOTE TO CUSTOMER TESTING PENDING. THE SHROUD USED ON THESE ASSEMBLIES PASSED THIS REQUIREMENT ON P/N 521971, VDE REG - NR 6718
- PRELIMINARY - NOT FOR PRODUCTION
- PART NUMBER WITH TUBE PACKAGING, TUBE PN:2384300-1

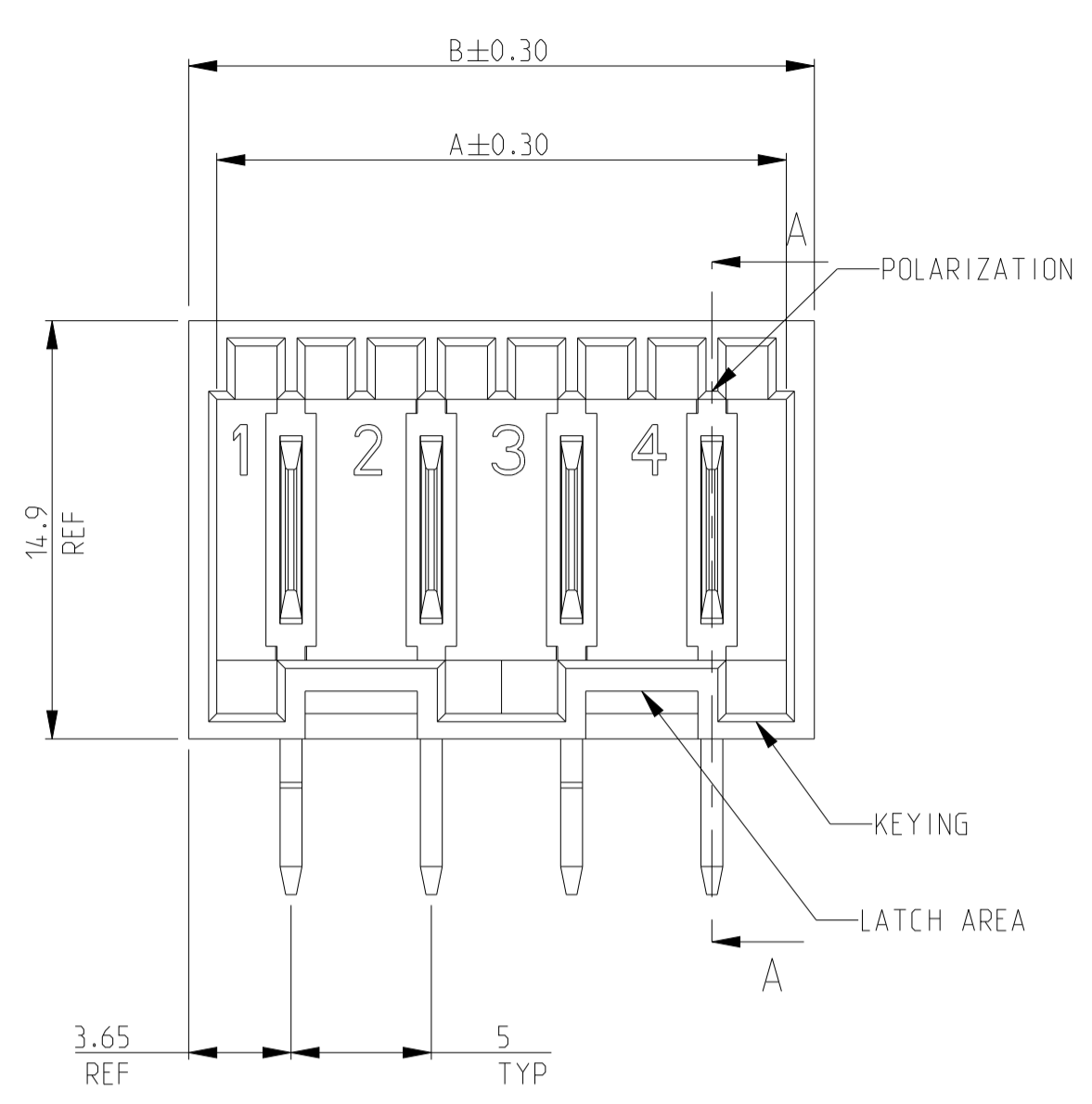
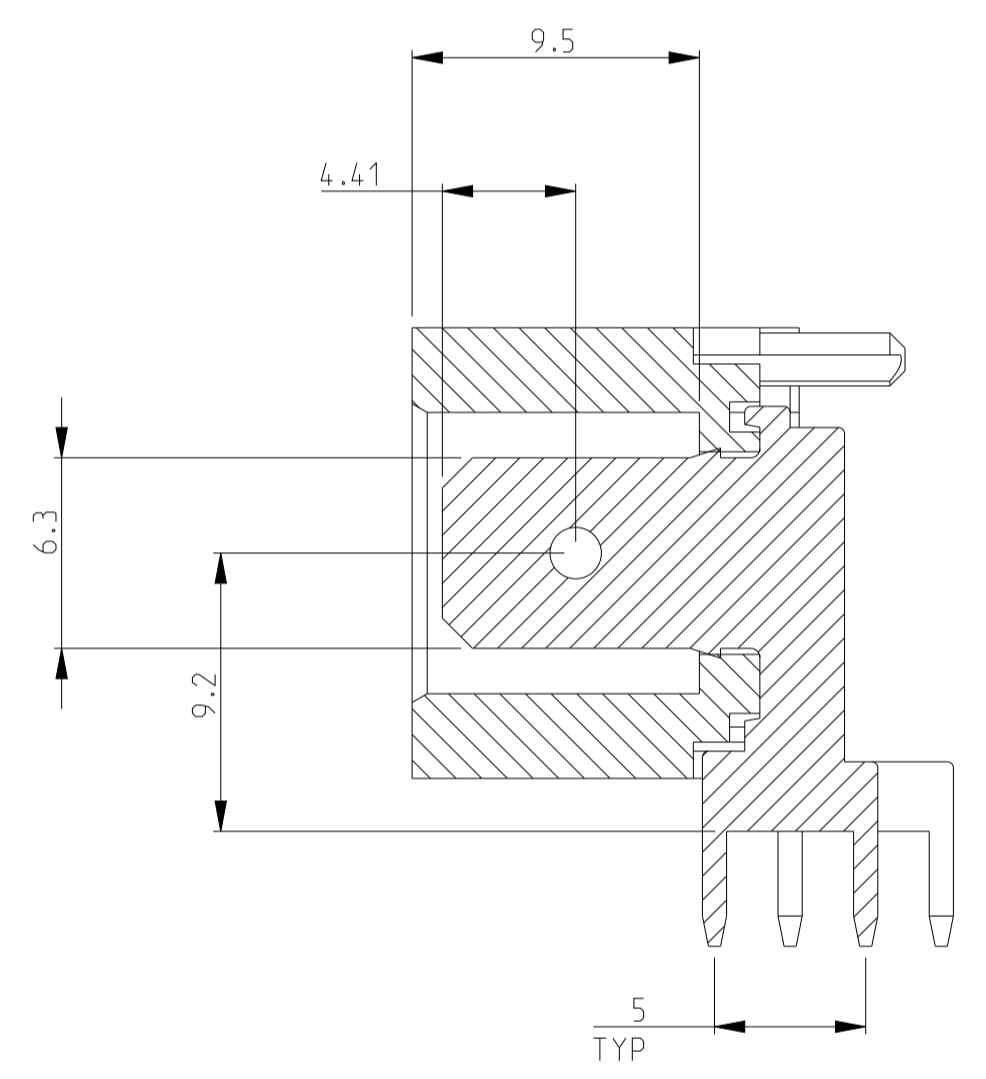
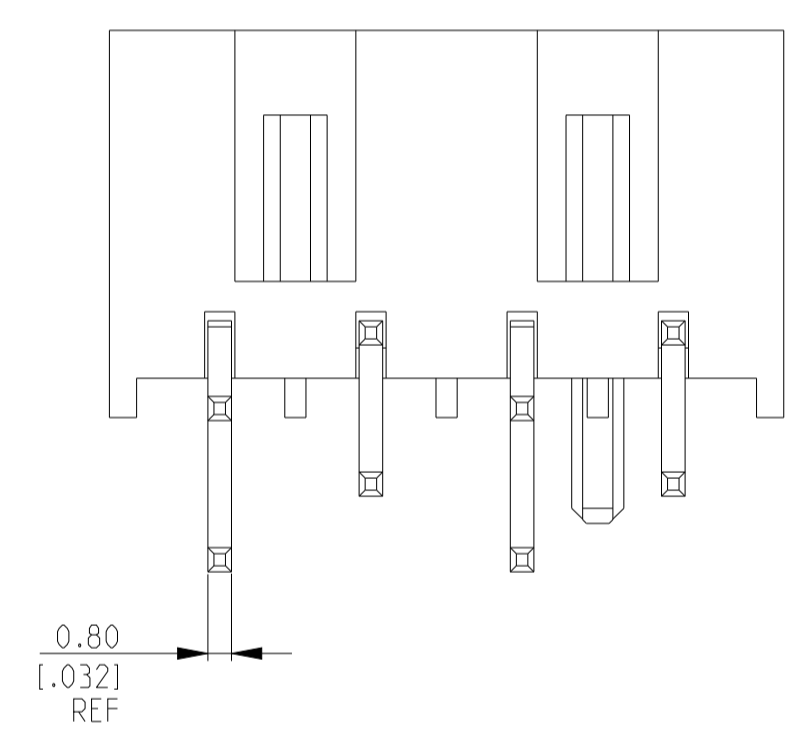

SECTION A-A

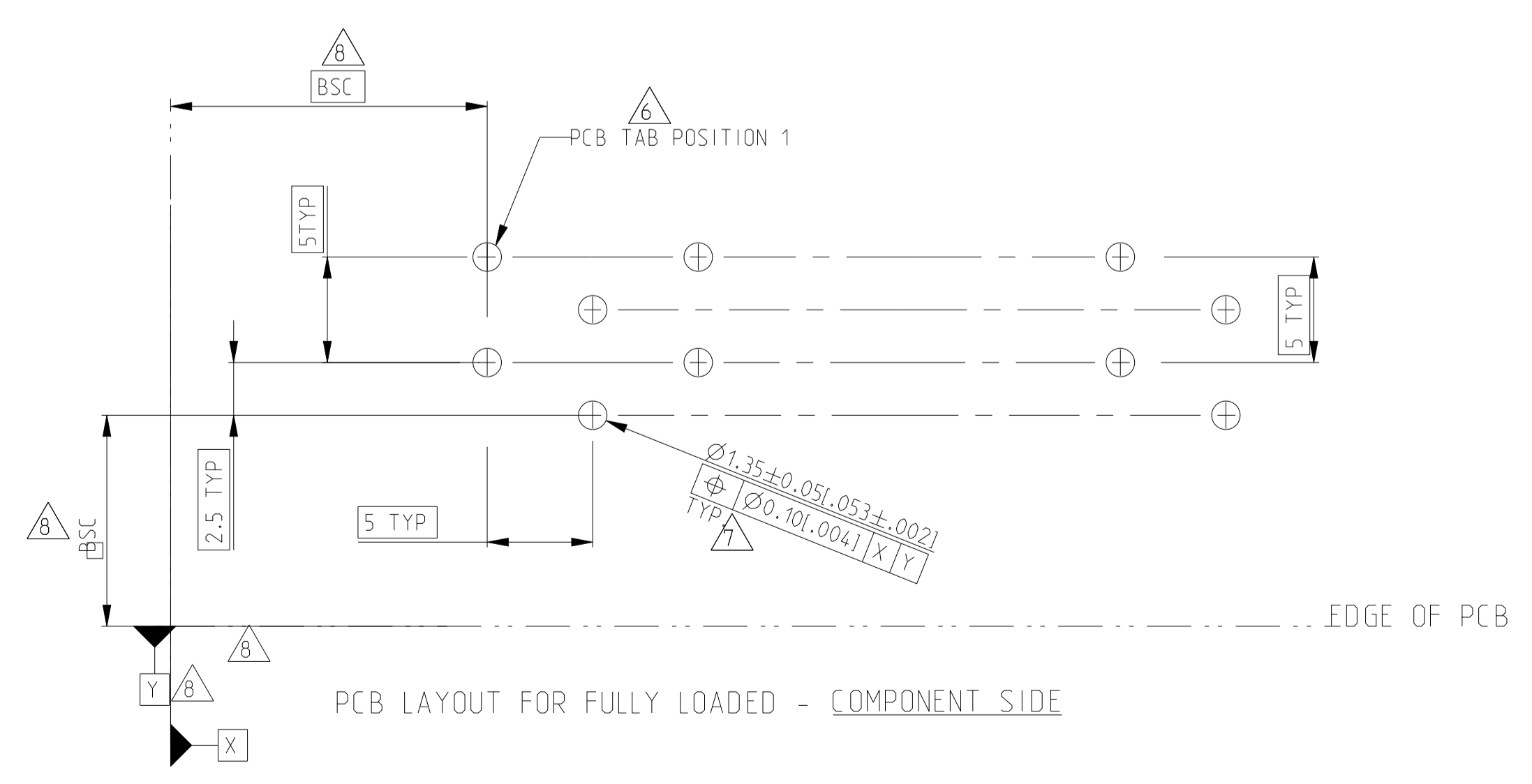

PCB LAYOUT FOR FULLY LOADED - COMPONENT SIDE

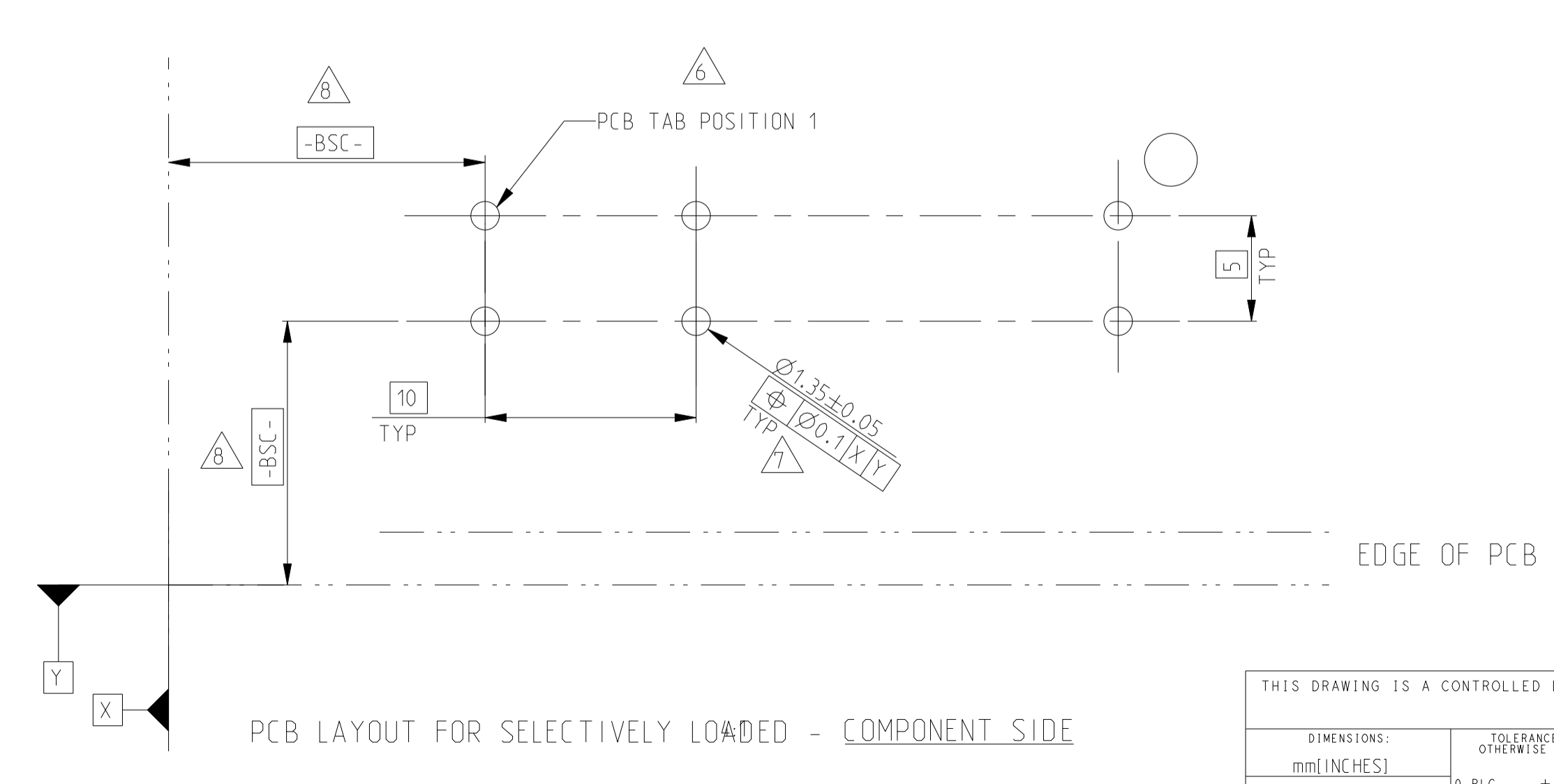

PCB LAYOUT FOR SELECTIVELY LOADED - COMPONENT SIDE

PCB 1.5±0.14 (1.059±.006) THICK  
 SCALE 4:1

47.3	45.3	9
42.3	40.3	8
37.3	35.3	7
32.3	30.3	6
27.3	25.3	5
22.3	20.3	4
17.3	15.3	3
12.3	10.3	2
B	A	NO. OF POS.

THIS DRAWING IS A CONTROLLED DOCUMENT.

DIMENSIONS: mm (INCHES)	TOLERANCES UNLESS OTHERWISE SPECIFIED:	DMN: RAGHAVENDRA 30MAR2010	CHK: JEFF RUTH 30MAR2010	APVD: RAY LONDON 30MAR2010	NAME: ASSEMBLY, DIN, RAST 5 HEADER, RIGHT ANGLE, GW T
0 PLC ±	1 PLC ±	2 PLC ±	3 PLC ±	4 PLC ±	5 PLC ±
ANGLES ±	FINISH ±	WEIGHT -	SIZE: A1	CAGE CODE: 00779	DRAWING NO: 1969352
MATERIAL: -	FINISH: -	REVISIONS: A4	SCALE: 4:1	SHEET: 1 OF 2	REV: A4

STE TE Connectivity

LOC	DIST	REVISIONS			
P	LTN	DESCRIPTION	DATE	DMN	APVD
-	-	SEE SHEET 1	-	-	-

### FULLY LOADED VERSION

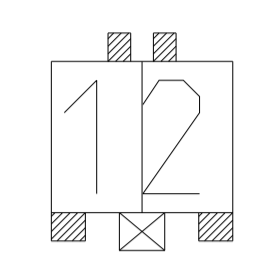

1969352-2

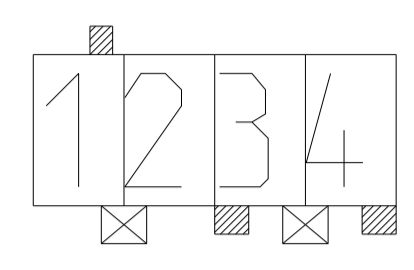

1969352-4

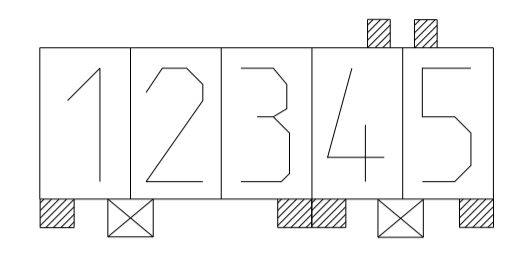

2-1969352-5

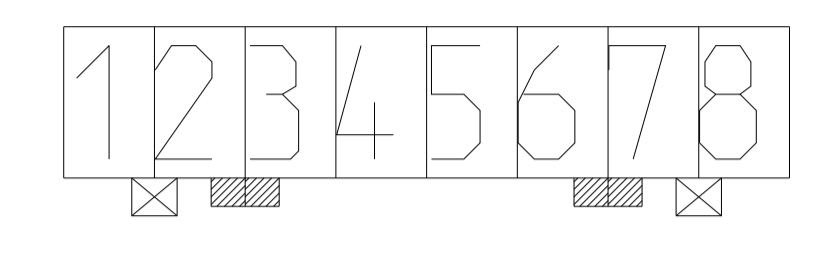

1969352-8

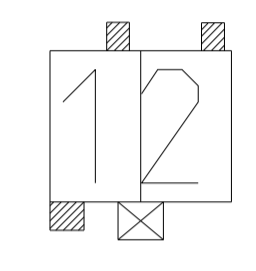

5-1969352-2

1-2,7-8	2d,3c,6d,7c	--	8	08-D	△1 1969352-8
1-2,2-3	1c,3d,4c,5d	4b,5a	5	-	2-1969352-5
1-2,3-4	3c,4d	1b	4	04-A	△1 1969352-4
1-2	1c	1b,2b	2	02-I	5-1969352-2
1-2	1c,2d	1b,2a	2	02-A	1969352-2
LATCH W INDOWS	KEYING	POLAR.	NO. OF POS.	RAST 5 DESIG.	PART NUMBER

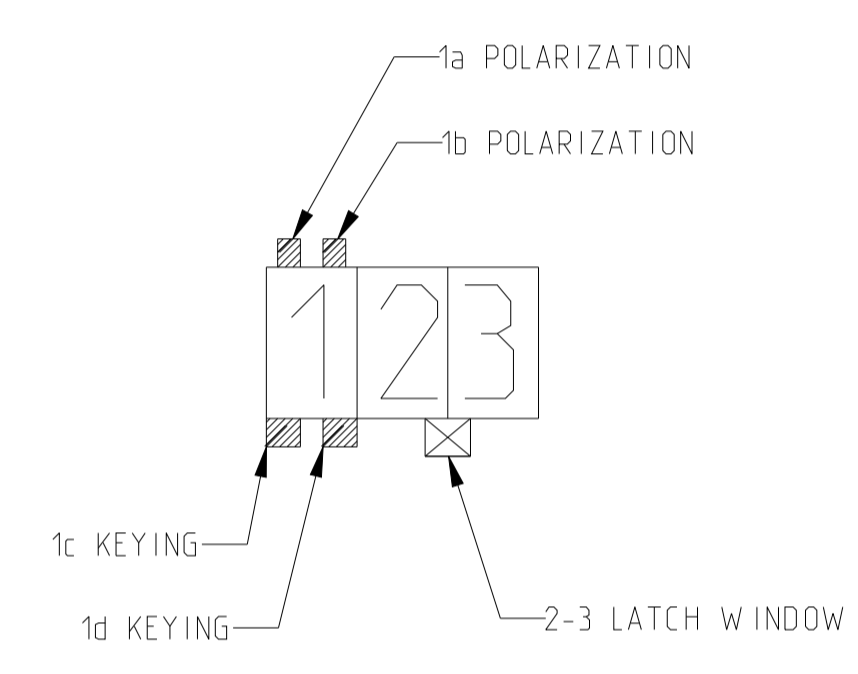

PICTORIAL VIEW KEY

### SELECTIVELY LOADED VERSION

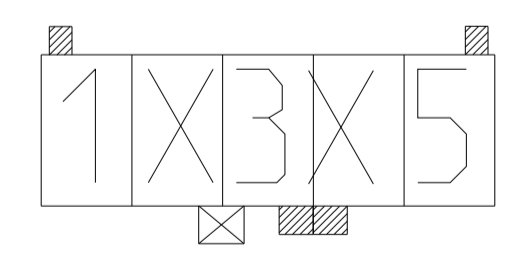

△2 2384394-5

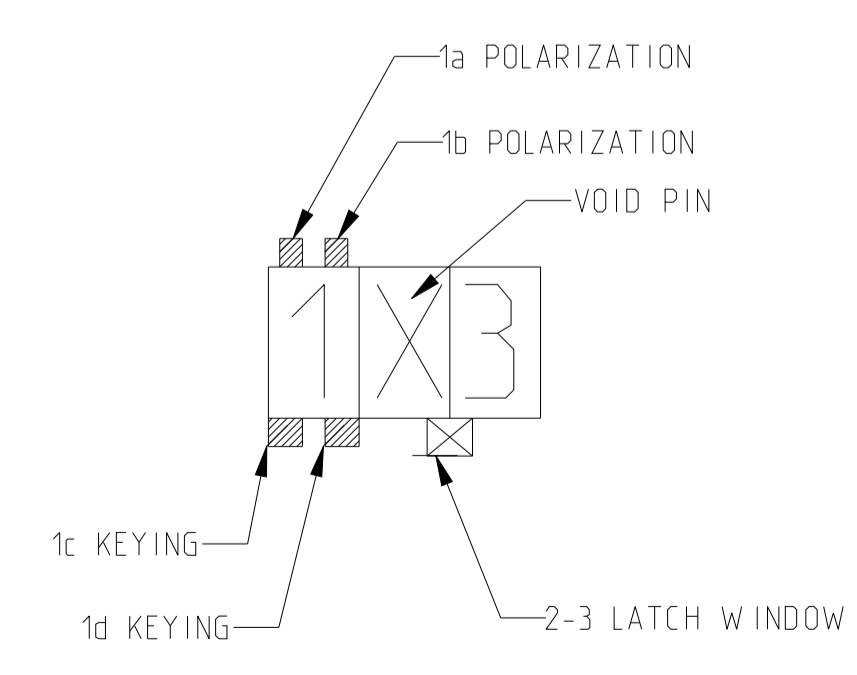

PICTORIAL VIEW KEY

2-3	3d,4c	1a,5b	5	-	2384394-5 △2
LATCH W INDOWS	KEYING	POLAR.	NO. OF POS.	RAST 5 DESIG.	PART NUMBER

THIS DRAWING IS A CONTROLLED DOCUMENT. DWN: RAGHAVENDRA 30MAR2010  
 CHK: JEFF RUTH 30MAR2010  
 APVD: RAY LONDON 30MAR2010

**STE** TE Connectivity

NAME: ASSEMBLY, DIN, RAST 5 HEADER, RIGHT ANGLE, GWT

SIZE: A1 CAGE CODE: 00779 DRAWING NO: 1969352 RESTRICTED TO: A4

MATERIAL: - FINISH: - WEIGHT: - SCALE: 3:1 SHEET 2 OF 2 REV: A4

CUSTOMER DRAWING