

88291100 & 88292100
QUICK DISCONNECT CONTACTS

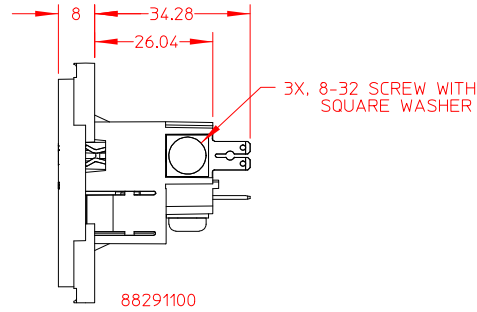

88291100

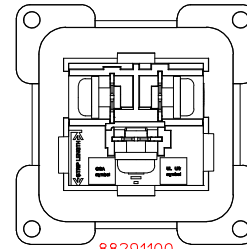

88291100

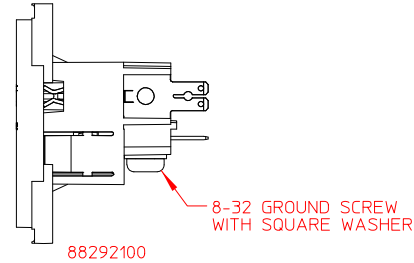

88292100

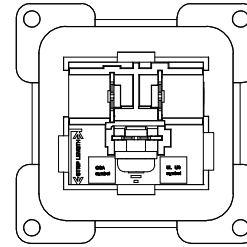

88292100

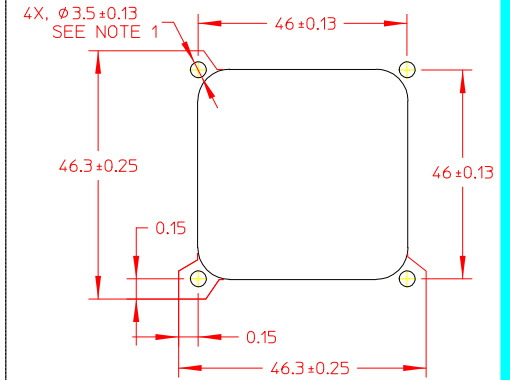

FRONT MOUNT PANEL CUTOUT
(SNAP-ON BEZEL)
OR REAR MOUNT PANEL CUTOUT
(NO SNAP-ON BEZEL)

THIS PANEL CUTOUT IS RECOMMENDED
WHEN USED IN COMBINATION WITH THE
88052XXX FAMILY OF SOCKETS.

NOTES:
1. RECOMMENDED DIAMETER FOR THRU-HOLE
(SCREW/NUT COMBINATION) HARDWARE MOUNTING
METHOD. OTHER METHODS WILL REQUIRE HOLES
WITH DIFFERENT DIMENSIONS AND PARAMETERS.

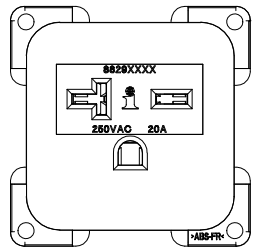

88293100 & 88294100
SOLDER TAB CONTACTS

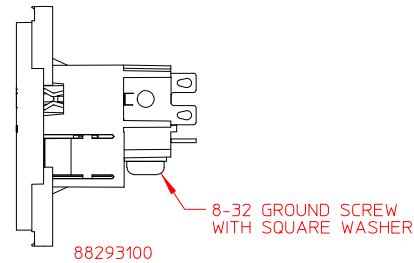

88293100

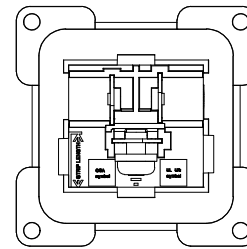

88293100

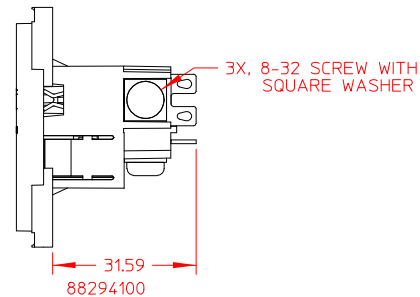

88294100

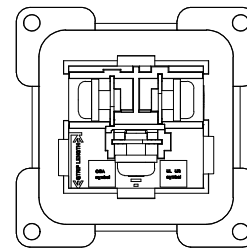

88294100

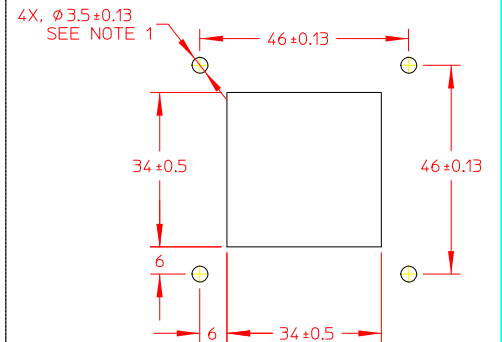

FRONT MOUNT PANEL CUTOUT
(SNAP-ON BEZEL)

THIS PANEL CUTOUT IS RECOMMENDED
FOR ALL OTHER APPLICATIONS.

THIS DOCUMENT AND ITS CONTENTS ARE THE PROPRIETARY, CONFIDENTIAL PROPERTY OF INTERPOWER CORPORATION. NO USE OR COPIES MAY BE MADE WITHOUT WRITTEN PERMISSION FROM INTERPOWER.

DIMENSIONS IN: MM

TITLE NEMA 6-20 SCREW MOUNT
ASSEMBLIES

DRAFT BY: BEM DATE: 8-26-15

PART NUMBER: 88291100, 88292100
88293100, 88294100

DRAFTING APPROVAL: SRK DATE: 8-26-15

MATERIAL:

DO NOT SCALE

INTERPOWER
CORPORATION

SHEET 1 OF 1

REV	DATE	BY	CHANGE DESCRIPTION
1	3		INITIAL RELEASE