

REV.	DESCRIPTION	DATE	APPROVED
M	Created MFG drawing and tables per ECO-1121	03/17/22	R. P.
N	Revision created to align with ECO-1125	04/08/22	M. P.
P	Release drawing per ECO-1136	05/27/22	R. P.

ORDERING INFORMATION:

9XX-XXX
 SERIES LENGTH
 INCHES, MULTIPLES OF .005"
 .030" = 030
 .100" = 100
 1.250" = 1.250
 WHOLE MILLIMETERS
 2mm = 2MM
 5mm = 5MM

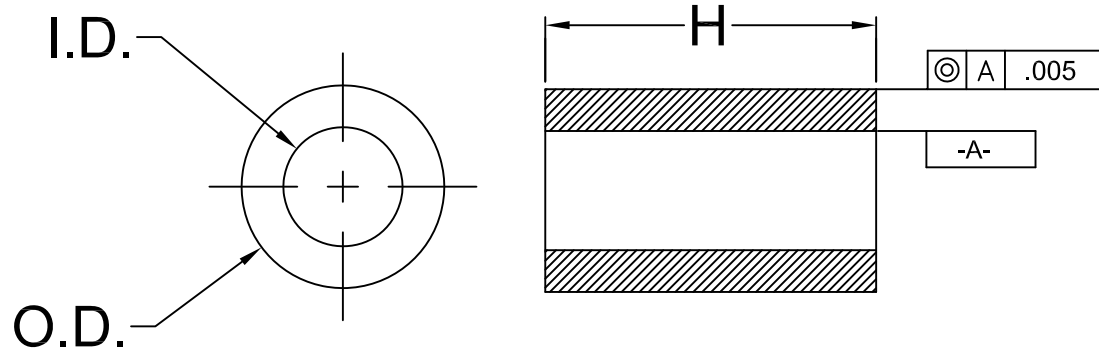

SERIES	"H" DIMENSION	I.D.	O.D.	Wall Thick (REF)
901	.030-1.250 (.76-31.8)	0.028 (0.71)	0.085 (2.2)	0.029 (0.72)
902	.030-1.250 (.76-31.8)	0.032 (0.81)	0.125 (3.2)	0.047 (1.18)
903	.030-1.250 (.76-31.8)	0.047 (1.2)	0.156 (4.0)	0.055 (1.38)
904	.030-1.250 (.76-31.8)	0.063 (1.6)	0.187 (4.7)	0.062 (1.57)
905	.030-1.250 (.76-31.8)	0.147 (3.7)	0.250 (6.4)	0.052 (1.31)
906	.030-1.250 (.76-31.8)	0.085 (2.2)	0.148 (3.8)	0.032 (0.80)
907	.030-1.250 (.76-31.8)	0.105 (2.7)	0.167 (4.2)	0.031 (0.79)
908	.030-1.250 (.76-31.8)	0.125 (3.2)	0.187 (4.7)	0.031 (0.79)
911	.030-1.250 (.76-31.8)	0.125 (3.2)	0.250 (6.4)	0.063 (1.59)
912	.030-1.250 (.76-31.8)	0.171 (4.3)	0.250 (6.4)	0.040 (1.00)
913	.030-1.250 (.76-31.8)	0.091 (2.3)	0.187 (4.7)	0.048 (1.22)
937	.030-1.250 (.76-31.8)	0.090 (2.3)	0.125 (3.2)	0.018 (0.44)
938	.030-1.250 (.76-31.8)	0.032 (0.8)	0.085 (2.2)	0.027 (0.67)
939	.030-1.250 (.76-31.8)	0.047 (1.2)	0.125 (3.2)	0.039 (0.99)
940	.030-1.250 (.76-31.8)	0.063 (1.6)	0.156 (4.0)	0.047 (1.18)

CUSTOMER USE DRAWING

3. TOLERANCE "H" DIMENSION:
 0.030 - 0.500 (1.0 - 12.7mm)±0.005(0.1mm)
 0.505 - 0.750 (12.8 - 19.1mm)±0.008(0.2mm)
 0.755 - 1.250 (19.2 - 31.8mm)±0.015(0.4mm)
2. MATERIAL: NYLON 6, NYCOA 589, CLEAR WITH 1% AVIENT AB0SAF WHITE NYLON CONCENTRATE.
 BIVAR MATERIAL CODE 01-CR-WE.
1. GENERAL SPECIFICATIONS: BIVAR EXTRUDED PRODUCT SPECIFICATION BV00-E103.

STANDARD TOLERANCE (UNLESS OTHERWISE SPECIFIED)		 4 THOMAS, IRVINE, CA. 92618 TEL: (949) 951-8808 FAX: (949) 951-3974		
DECIMALS	ANGULAR			
.X ±.1	X° ± 1°	TITLE: NYLON TUBE SPACERS		
.XX ±.01				
.XXX ±.005			PART NO: 9XX-XXX	REVISION: P
DESIGNED: Michael Chen	DATE: 01/13/03	CAGE CODE : 32559 SHEET # 1 OF 1		
CHECKED: R. Pereyra	DATE: 04/08/22	CAD GENERATED DOCUMENT, DO NOT MEASURE DRAWING.		