

Description

Single pole, miniaturised, aircraft style thermal circuit breaker with tease-free, trip-free, snap action mechanism and push/pull on/off manual actuation (M-type TO CBE to EN 60934). An indicator band on the push button shows clearly the tripped/off position. Threadneck panel mounted, available in metric and US (MS 3320) configurations. Advanced two-chamber design contributes to fail-safe operation. Temperature compensated from -55° to +125°C, with optional auxiliary contacts, and fully approved for use on a wide range of aircraft and equipment. Full specification ensures suitability for the most demanding applications. For three pole version see type 583.

Typical applications

Aircraft systems and equipment (fixed wing and helicopters); other extra low voltage wiring applications; defence equipment; communications systems.

Standard current ratings and typical volt drop values

Current rating (A)	Volt drop (mV)	Current rating (A)	Volt drop (mV)
1	750	10	190
2	520	15	190
2.5	400	20	200
3	360	25	170
4	350	30	160
5	260	35	150
7.5	230		

Approvals

LN 29886
 VG 95345, part T6
 prEN 2995
 MS 3320
 QPL
 UL

All dimensions without tolerances are for reference only. In the interest of improved design, performance and cost effectiveness the right to make changes in these specifications without notice is reserved. Product markings may not be exactly as the ordering codes. Errors and omissions excepted.



Technical data

Voltage rating	AC 115 V* (400 Hz); DC 28 V* *UL: AC 250 V; DC 65 V	
Current rating range	1...35 A	
Auxiliary circuit	0.5 A, DC 28 V	
Typical life	20,000 operations mechanical or 10,000 operations at I_N (≤ 25 A) 5,000 operations at I_N (30 + 35 A)	
Ambient temperature	-55...+125 °C (-67...+257 °F)	
Insulation co-ordination (IEC 60664 and 60664A)	Rated impulse withstand voltage 1.5 kV	Pollution degree 3
Dielectric strength (IEC 60664 and 60664A) operating area main to aux. circuit	Test voltage AC 1,500 V AC 1,500 V	
Insulating resistance	>100 M Ω (DC 500 V)	
Interrupting capacity I_{cn} AC 115 V (400 Hz):	≤ 4 A 5 A 7.5...35 A	1,000 A 2,000 A 2,500 A
DC 28 V:	1...25 A 30 + 35 A	6,000 A 4,000 A
Degree of protection (IEC 60529/DIN 40050)	operating area IP 40 terminal area IP 00	
Vibration (sinusoidal)	15 g (70-2000 Hz) ± 0.76 mm (5-70 Hz) to VG 95210, sheet 19/ IEC 60068-2-6, test Fc/ISO 7137	
Vibration (random)	16.4 g rms, 0.2 g ² /Hz ± 1.5 dB to VG 95210, sheet 29/ISO 7137	
Acceleration	17 g, to ISO 2669	
Shock	75 g (11 ms) to VG 95210, sheet 28/ IEC 60068-2-27, test Ea/ISO 7137	
Corrosion	96 hours at 5 % salt mist, severity A 48 hours at 20 % salt mist, severity B to VG 95210, sheet 2/ IEC 60068-2-11, test Ka/ISO 7137	
Humidity	240 hours at 95 % RH, to VG 95210, sheet 7/ IEC 60068-2-3, test C/ISO 7137	
Explosion	to VG 95210, sheet 10/ MIL-STD-202, meth. 109	
Altitude	$\leq 25,000$ m above sea level	
Mass	max. 29 g with auxiliary contact max. 25 g without auxiliary contact	
Weight reduction through aluminium threadneck: approx. 3 g		

Ordering information

Type No.

483 single pole, with temperature compensation

Mounting

- G threadneck panel mounting, standard
- L threadneck panel mounting, extended push button
- V threadneck panel mounting, high vibration performance

Threadneck design

- 1 M12x1x6.4x8.8 dia. with mounting plate (aux.contact version)
- 2 15/32-32UNSx6.4x7.8 dia. (without aux. contact)
- 3 MJ12x6.4x8.8 dia. (without aux. contact)
- 4 M12x1x6.4x8.8 dia. (without aux. contact)
- 5 7/16-32UNSx6.4x7.8 dia. (without aux. contact)
- 6 M12x1x9.4x8.8 dia. (without aux. contact)
- 7 7/16-32 UNSx6.4x7.8 dia. with mounting plate (aux.contact version)
- 8 as 483-G1...but with aluminium threadneck (G, H and aux. contact versions S1, S5)

Hardware for threadneck (washers)

- 0 without hardware
- 1 wave washer 12/15 - mounted
- 2 mounted washer 12.1/17.2 - mounted
- 3 mounted washer 11.3/14.9 - mounted (threadneck design 5, 7 only)
- 4 mounted washer 12/15 - mounted
- 5 tooth washer 12.1/17.2, bulk shipped

Hardware for threadneck (nuts)

- 0 without hardware
- 1 hex nut M12x1 (threadneck design 1, 4, 6 only)
- 2 hex nut 15/32-32UNS (threadneck design 2 only)
- 3 hex nut 7/16-32UNS (threadneck design 5, 7 only)
- 4 hex nut M12x1, aluminium, fitted (threadneck design 8 only)
- 5 hex nut MJ12x1 (only with threadneck design 3)
- 6 hex nut M12x1, bulk shipped (threadneck design 1,4,6)

Terminal design (main terminals)

- K screws terminals with metric thread
 - 1 K14 (M4, MJ4)
- J screw terminals with inch thread
 - 1 J14 (8-32UNC-2B)
 - 2 J17 (8-32UNC-2B)
 - 3 J25 (6-32UNC-2B)

Characteristic curve

M1 thermal, 1.15-1.38 I_N

Terminal screws

- A Phillips screw M4x6
- B Phillips screw 8-32UNC-2Ax6
- C Phillips screw 6-32UNC-2Ax6
- D slotted flat head screw M4x6
- E hex screw with Phillips head 8-32UNC-3A-9.5
- K hex screw with Phillips head 8-32UNC-3Ax7.6 (ASN E0736)
- L Phillips screw MJ4x6
- M as "K" but bulk shipped
- Z without screws

Terminal washers

- 0 without lock washer
- 1 lock washer B4
- 2 lock washer 4.3
- 3 lock washer B4 and washer 4.4/9.5
- 4 lock washer 3.7
- 5 lock washer 4.3/9 (ASN A2553)

Auxiliary contact

- S0 without auxiliary contact
- S1 with auxiliary contact (N/C) connector to EN3155-016M2018, size 20
- S5 with polarized auxiliary contact (N/C)

Barrier

- Z without barrier (standard)

Colour of the push button

- blank: black (standard) (e.g. 7.5)
- A green (e.g. 7.5)
- G green, marking to EN (e.g.7 1/2)
- N black, marking to EN (e.g.7 1/2)

483 - G 4 1 1 - K1 M1 - A 1 S0 Z . - ...

Ordering information

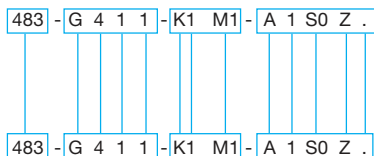

1...35 A

5 A

ordering example

Ordering information for approved devices

483-G411-K1M1-A1S0ZN (483-96-TC-K14)

Metric threadneck M12x1 and terminal design -K14 (M4x6), listed by the German Materialamt der Bundeswehr to VG 95345, part 6.

483-G111-K1M1-A1S1ZN

Metric threadneck M12x1 and terminal design -K14 (M4x6) and auxiliary contact -Si, listed by the German Materialamt der Bundeswehr to VG 95345, part 6.

483-G533-J1M1-B2S0ZN (MS 3320)

Threadneck size 7/16-32UNSx6.4 and terminal design -J14 (inch thread 8-32), approved to MS 3320.

483-V533-J1M1-B2S0ZN (MS 3320-V)

Threadneck size 7/16-32UNSx6.4 and terminal design -J14 (inch thread 8-32), approved to MS 3320-V.

483-G533-J3M1-C4S0Z (483-TC-G11-J25)

Threadneck size 7/16-32UNSx6.4 and terminal design -J25 (inch thread 6-32), complies with MS26574.

483-G814-K1M1-A1S1ZN

Aluminium threadneck M12x1x6.4x8.8 dia. Complies with EN2995.

Internal connection diagrams

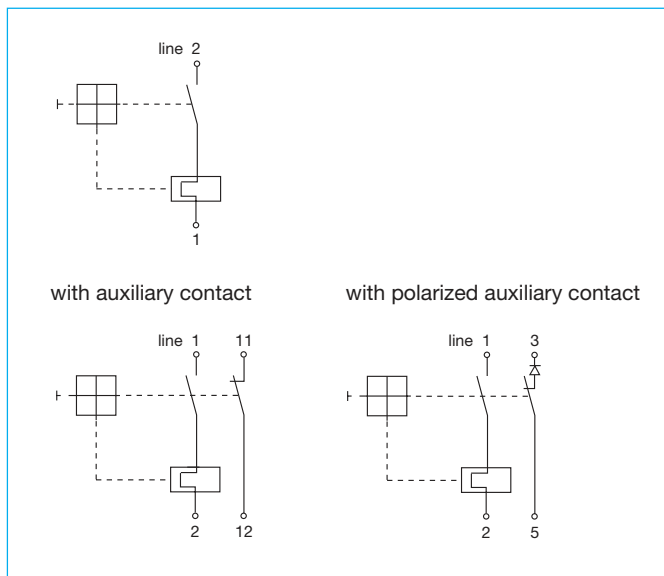

Dimensions 483-G411-K1M1-A1S0ZN

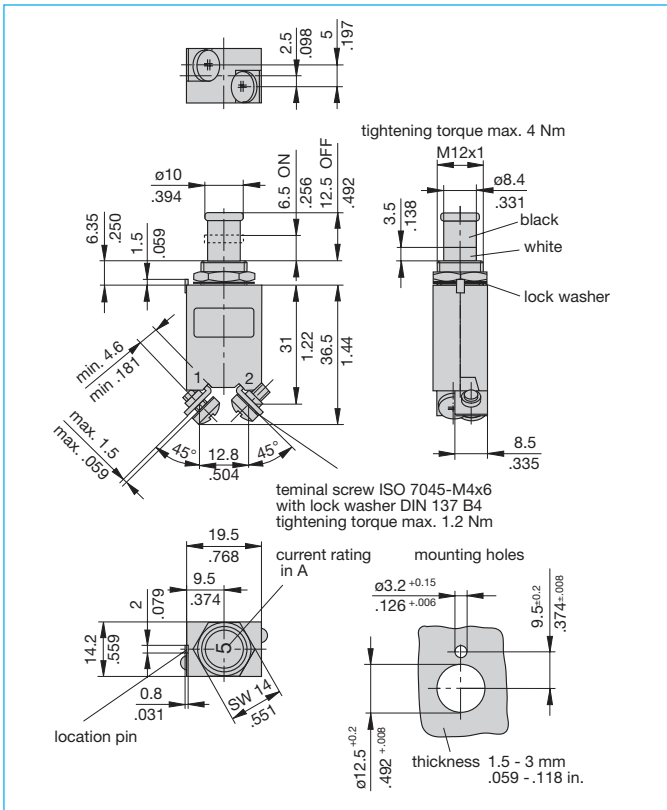

Dimensions 483-G111-K1M1-A1S1ZN

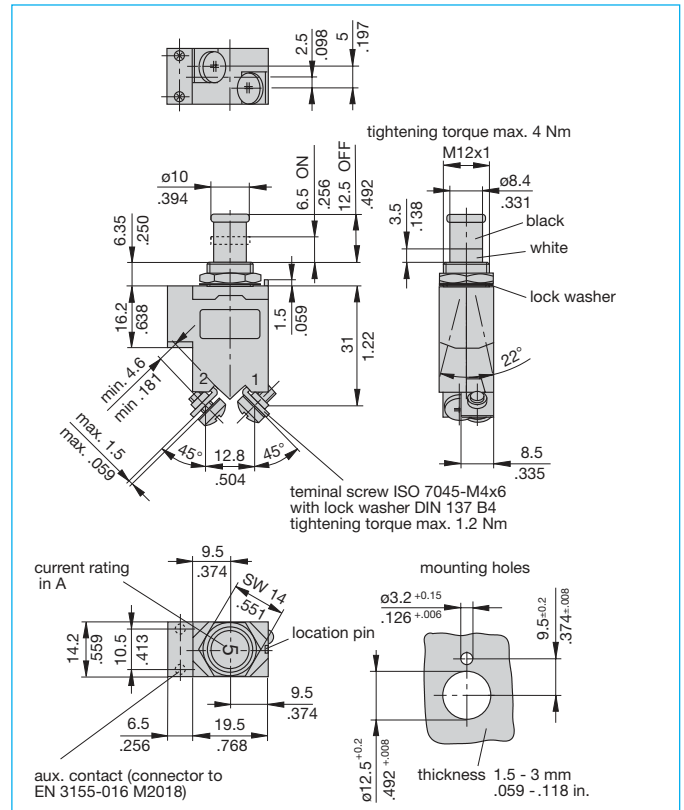

Dimensions 483-G533-J1M1-B2S0ZN (MS 3320)

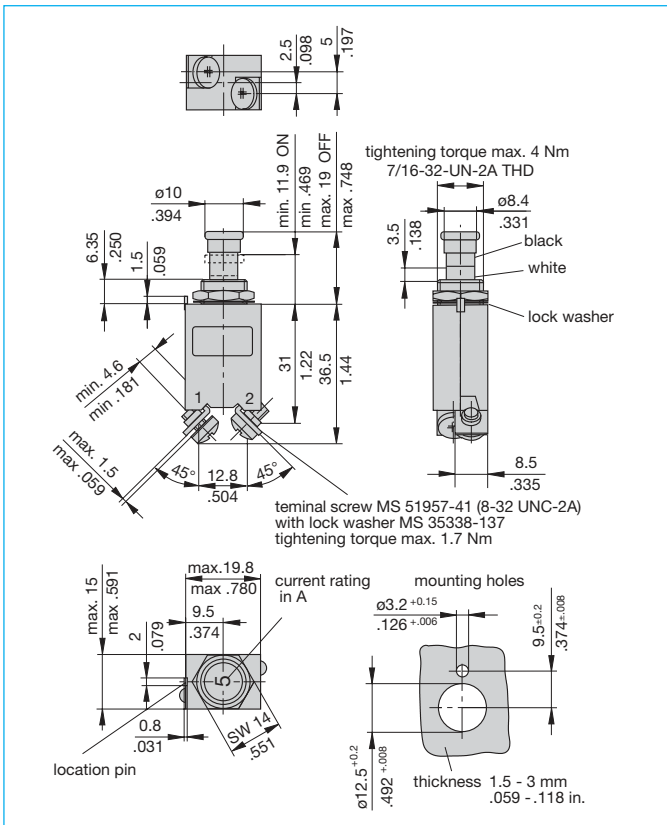

Mounting holes

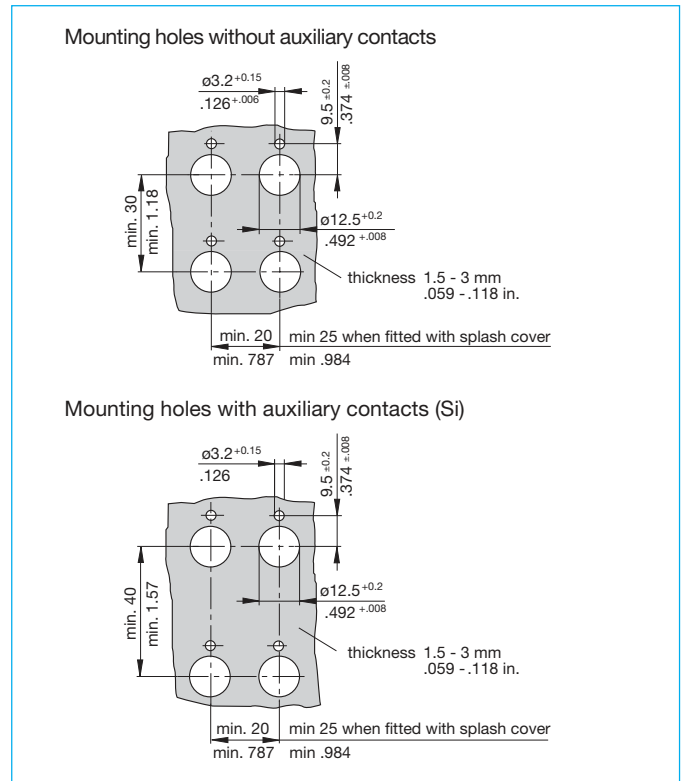

This is a metric design and millimeter dimensions take precedence (mm/inch)

Other main terminal designs

-J2

Terminal distances to:
 MS 14 105 (a, b)
 MS 14 153 (a, b)
 MS 22 073 (a)
 MS 22 074 (a)
 MS 25 244 (a)
 MS 25 373 (a, b)

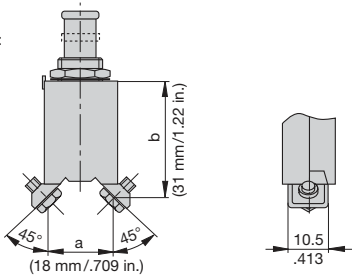

-J3

Terminal distances to:
 MS 26 574 (a, b)

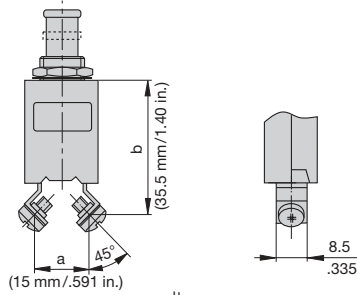

-G6

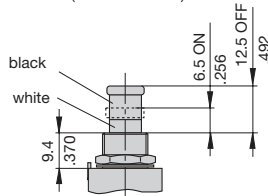

-L2/5/7

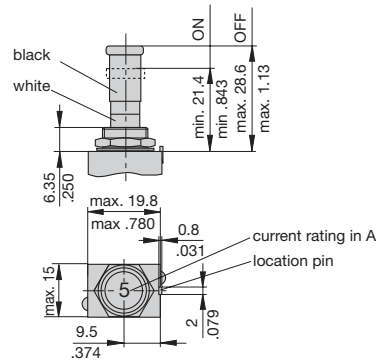

Typical time/current characteristics

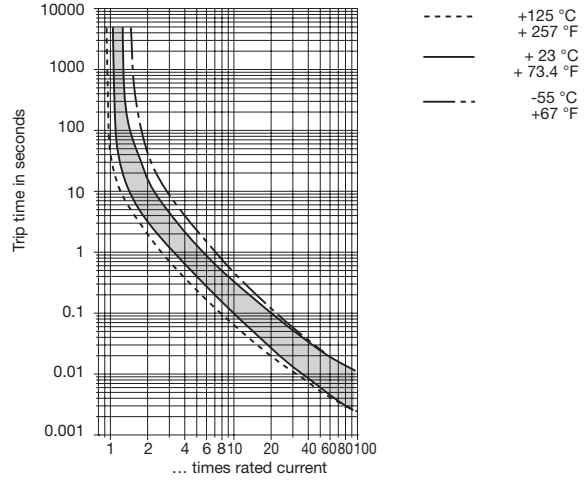

Accessories

Splash cover/hex nut assembly with O ring (IP 66)

(approved to VG 95345, part 23)
 X 200 801 08 nickel plated nut M 12x1, transparent cover
 X 200 801 03 matt black finish nut M 12x1, black cover
 X 200 801 09 matt black finish nut 7/16-32, black cover

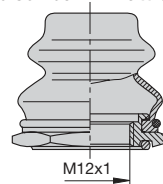

Splash cover black/hex nut assembly with O ring (IP 54)

(approved to VG 95345, part 23)
 X 200 802 01 nickel plated nut
 X 200 802 02 matt black finish nut

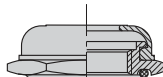

Actuator extension, black (approved to VG 95345, part 23)

X 200 803 01

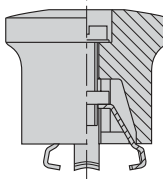

Lock out ring Y 307 005 01 red

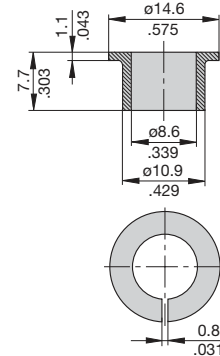

Accessories

Identification collar
 Y 307 004 01 black
 Y 307 004 02 white
 Y 307 004 03 red
 Y 307 004 04 green
 Y 307 004 05 blue

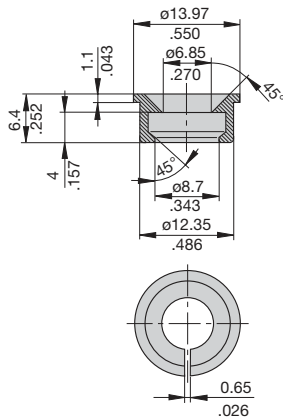

This is a metric design and millimeter dimensions take precedence (mm / inch)