

Product Number	Type	Packaging
10128841-001LF	WITH COMPLIANT PINS	Tray
10128841-002LF	WITHOUT COMPLIANT PINS	Tray

COMPLIANT PINS

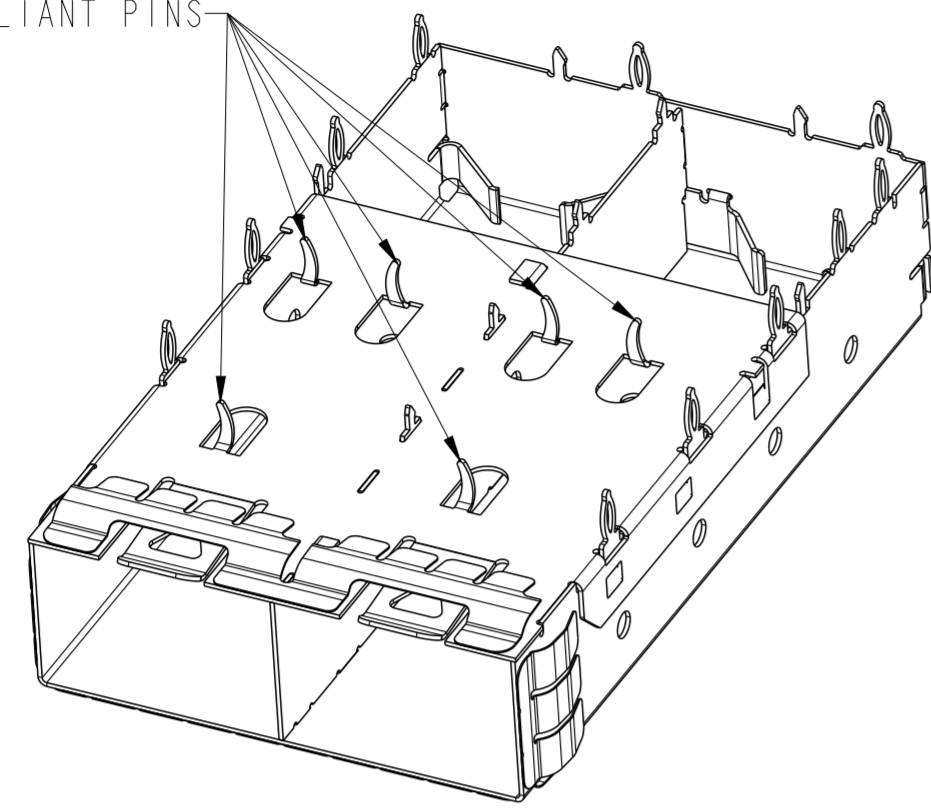

10128841-001LF
SCALE 5:2

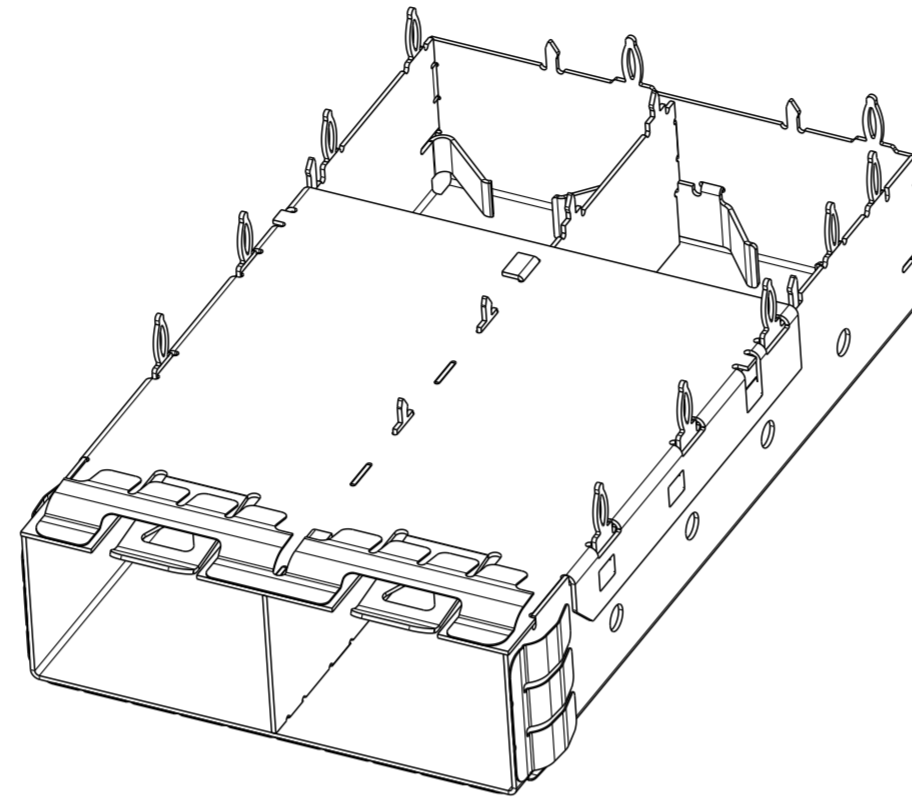

10128841-002LF
SCALE 5:2

NOTES:

1, DESCRIPTION	Q'TY	MATERIAL	PLATING
CAGE ASSEMBLY	1PCS	COPPER ALLOY T=0.25	Ni PLATED
EMI SPRING	4PCS	COPPER ALLOY T=0.08	Ni PLATED
CLIP	1PCS	STAINLESS STEEL T=0.30	N/A
HEAT SINK	2PCS	ALUMINUM ALLOY	BLACK ANODIZING COATING
LIGHTPIPE	2PCS	POLYCARBONATE.CLEAR	N/A

2, PRODUCT SPECIFICATION: GS-12-1165
3, APPLICATION SPECIFICATION: GS-20-0384
4, PACKAGE PER GS-14-2344 AND GS-14-920

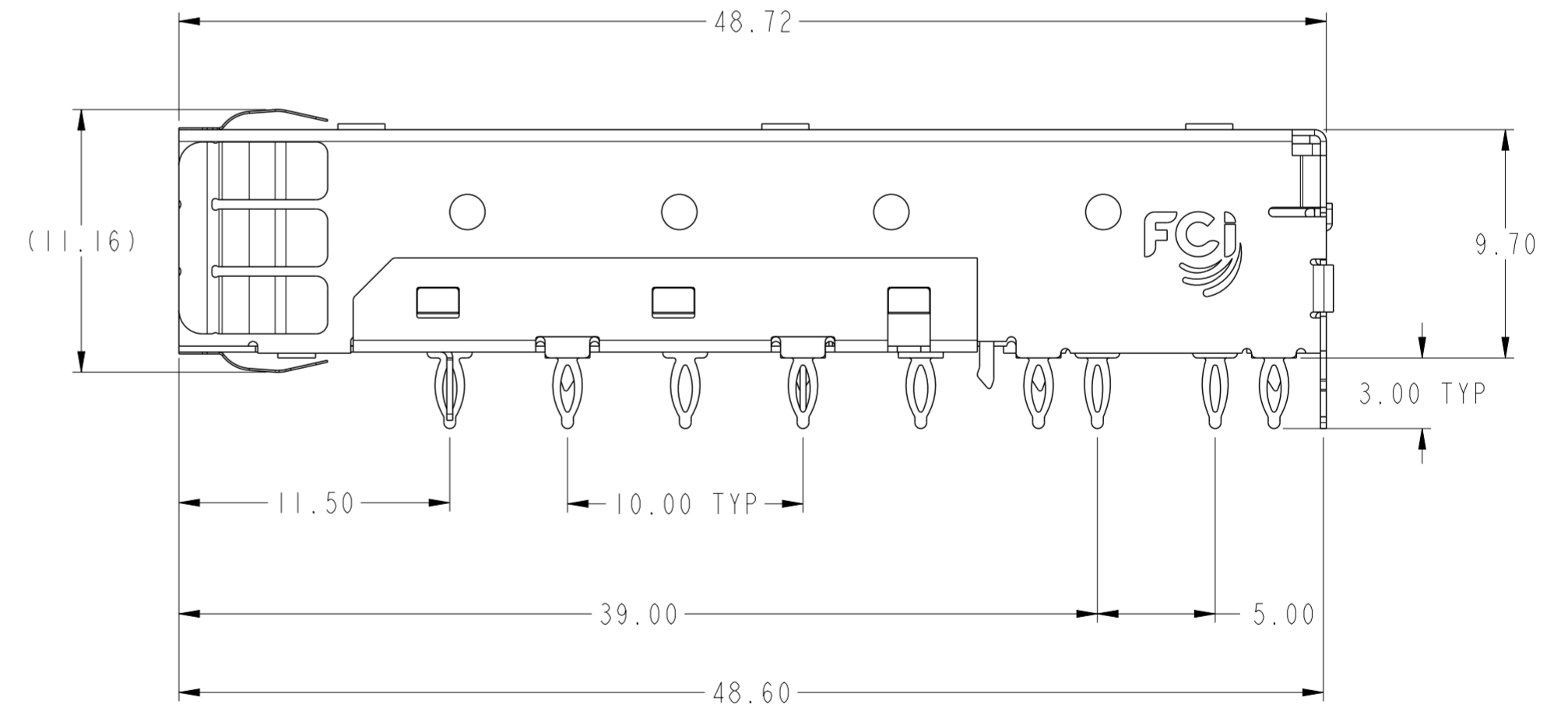
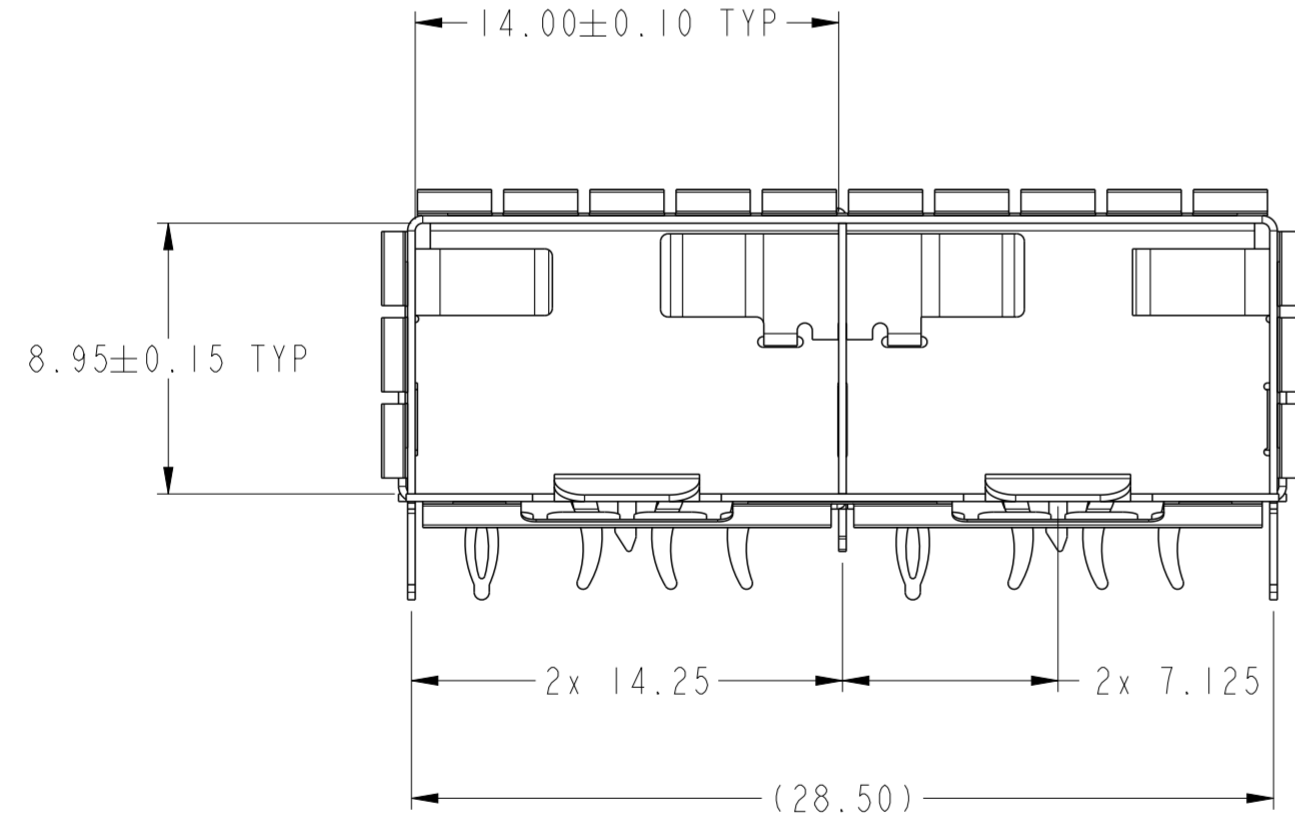

spec ref	dr	Art Lin	2014/04/21	projection	mm	size	A2	scale	5:2
tolerance std	eng	Art Lin	2015/02/09		mm	ecn no	-	rel level	Released
ISO 406	chr	-	product family						
ISO 1101	appr	Collins Lu	2015/02/09			SFP+ 1X2 CAGE ASSEMBLY		10128841	
surface	linear	0.X	±0.25			LOW PROFILE, SPRING FINGER		A	
ISO 1302	angular	0°	±1°	www.fci.com		cat. no. -		Product - Customer Drw	

Product Number	Packaging
10128841-101LF	Tray

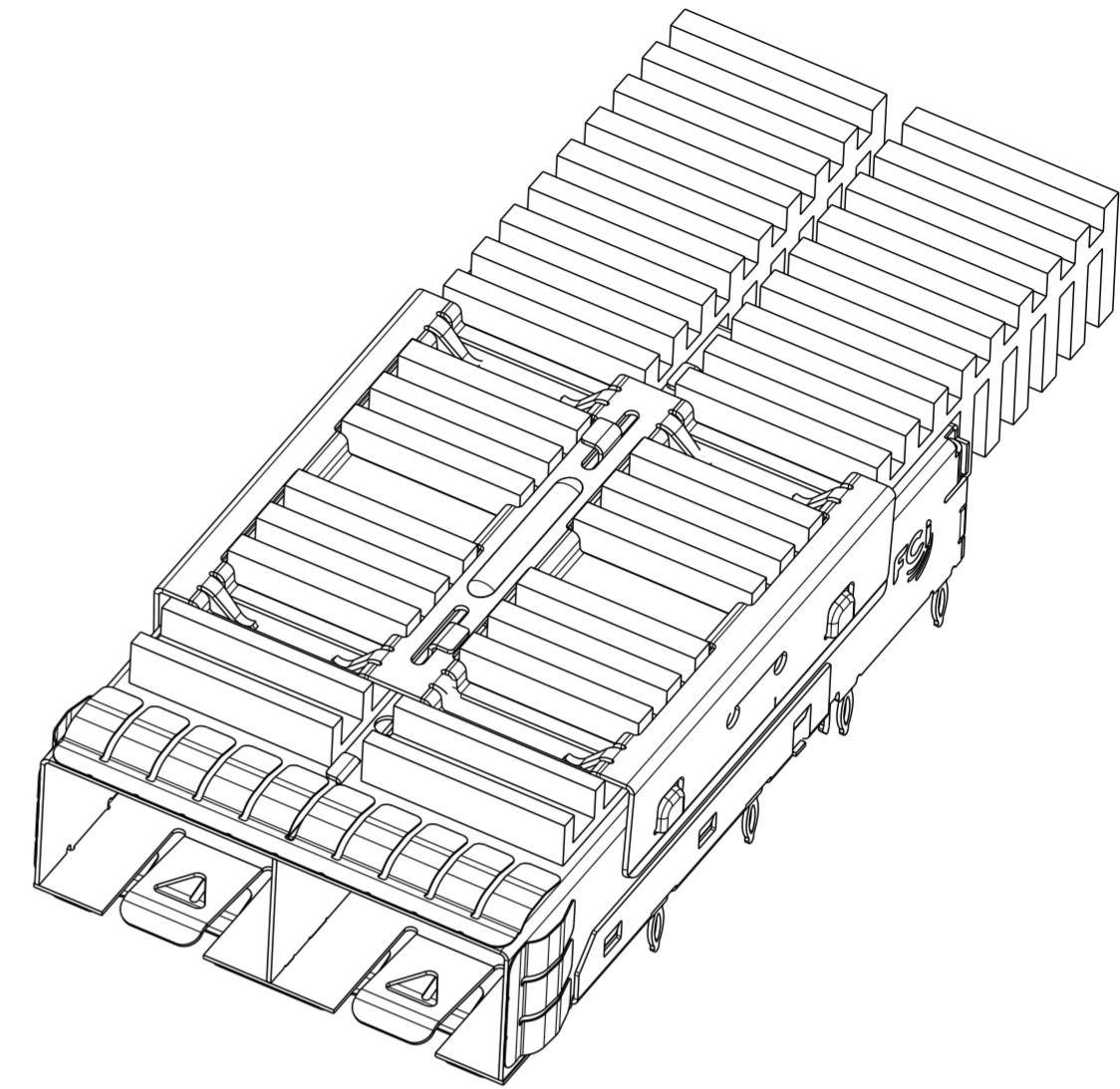
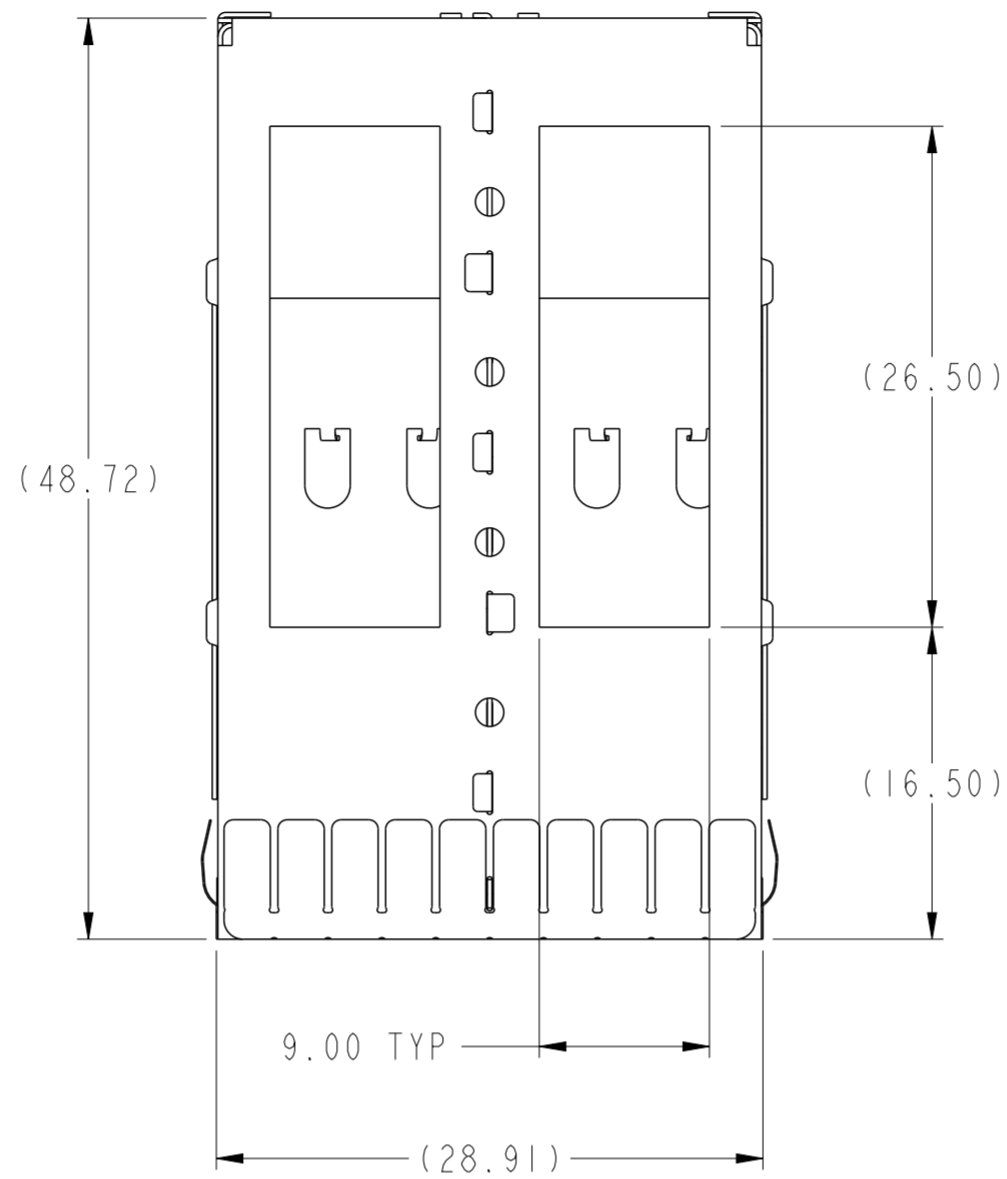
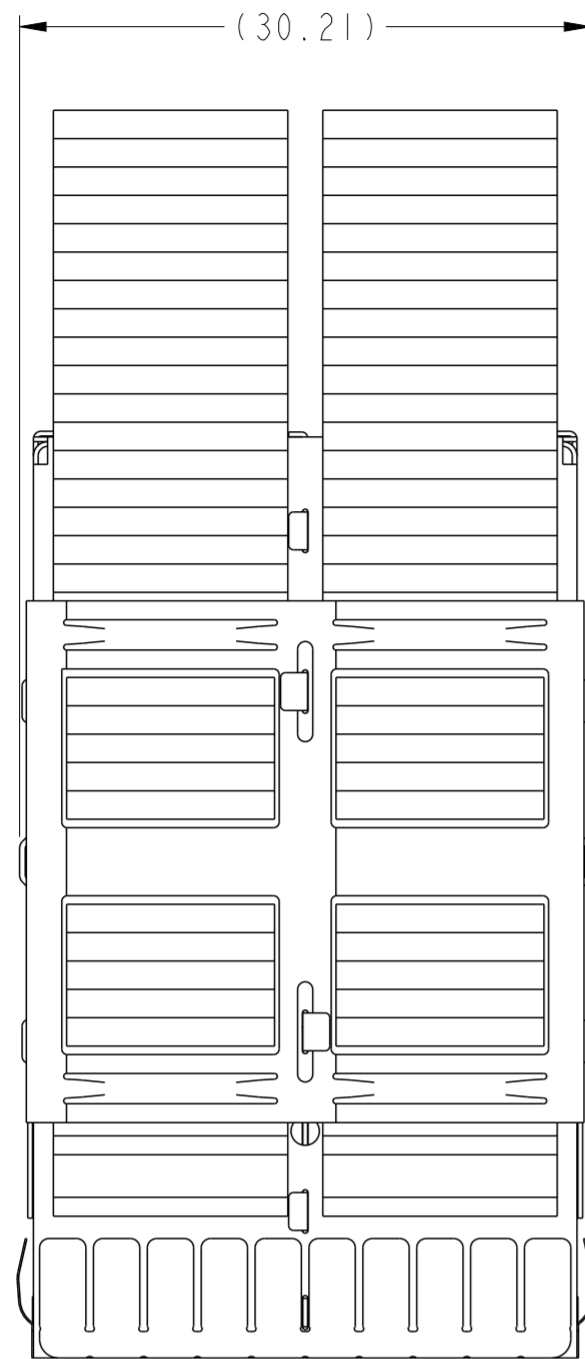

ASSEMBLY VIEW
SCALE 5:2

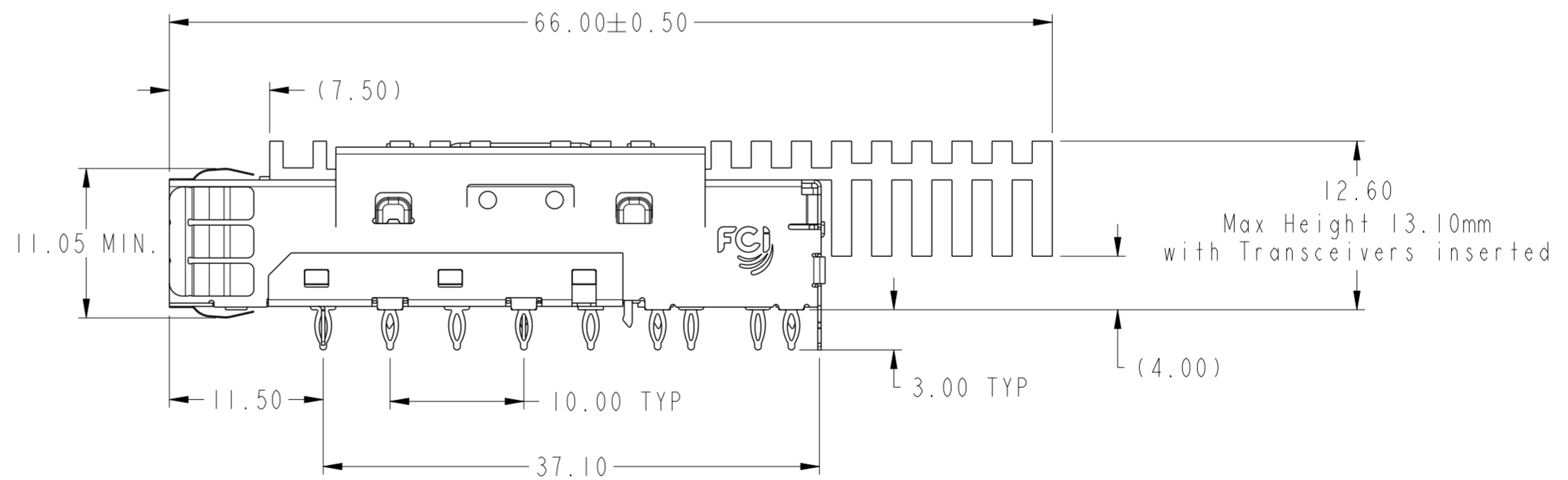
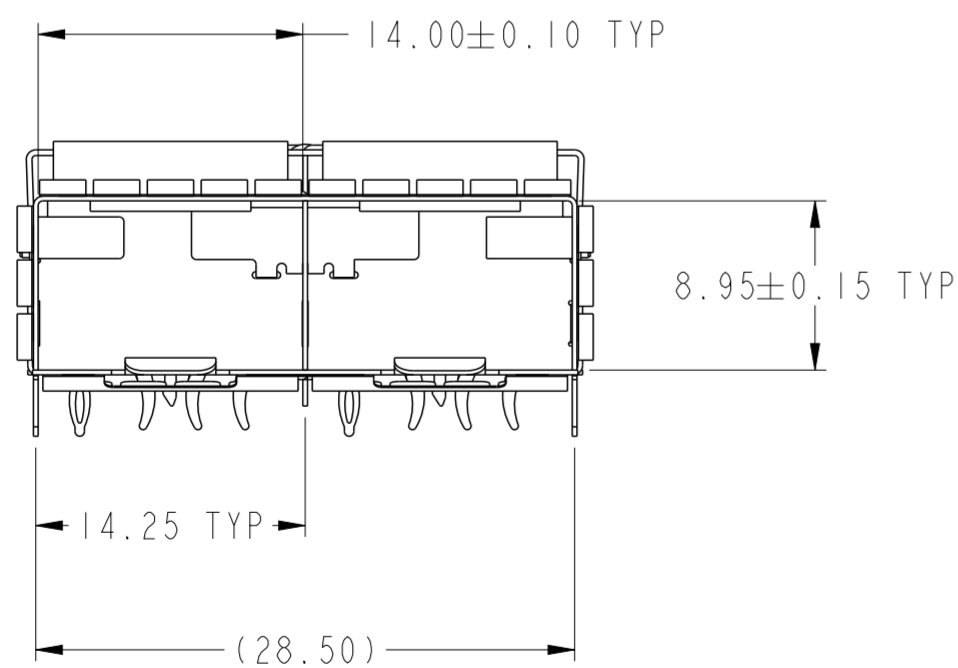

Copyright FCI.
FCI

spec ref	dr	Art Lin	2014/04/21	projection	mm	size	A2	scale	5:2
tolerance std	eng	Art Lin	2015/02/09		mm	ecn no	-	rel level	Released
ISO 406 ISO 1101	chr	-	product family						
TOLERANCES UNLESS OTHERWISE SPECIFIED	appr	Collins Lu	2015/02/09			SFP+ 1X2 CAGE ASSEMBLY LOW PROFILE, SPRING FINGER		dwg no 10128841	rev A
surface	linear	0.X	±0.25	www.fci.com		cat. no.		Product - Customer Drw	sheet 2 of 11
ISO 1302	angular	0°	±1°	PDS: Rev :A		STATUS:Released		Printed: Feb 09, 2015	

Product Number	Packaging
10128841-102LF	Tray

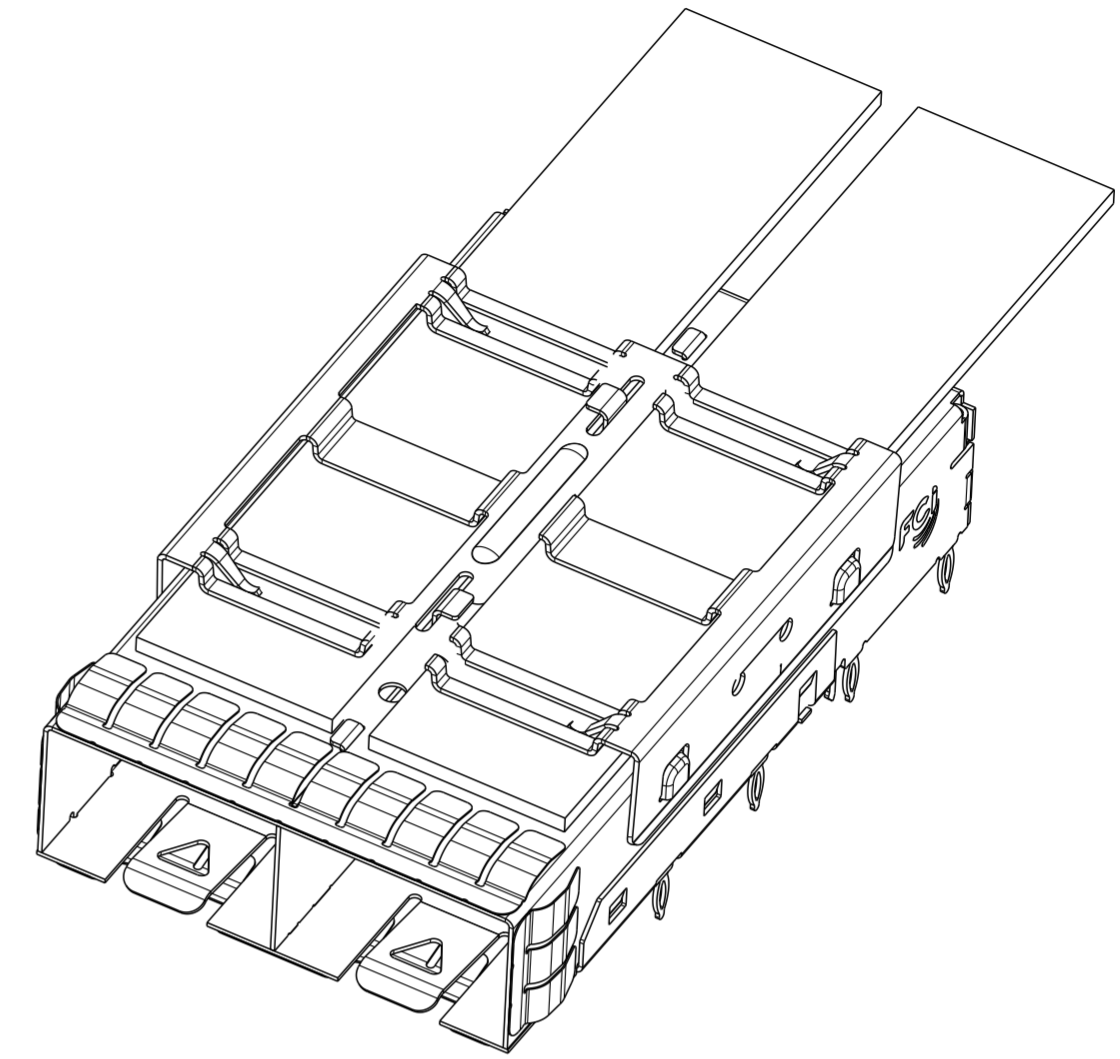
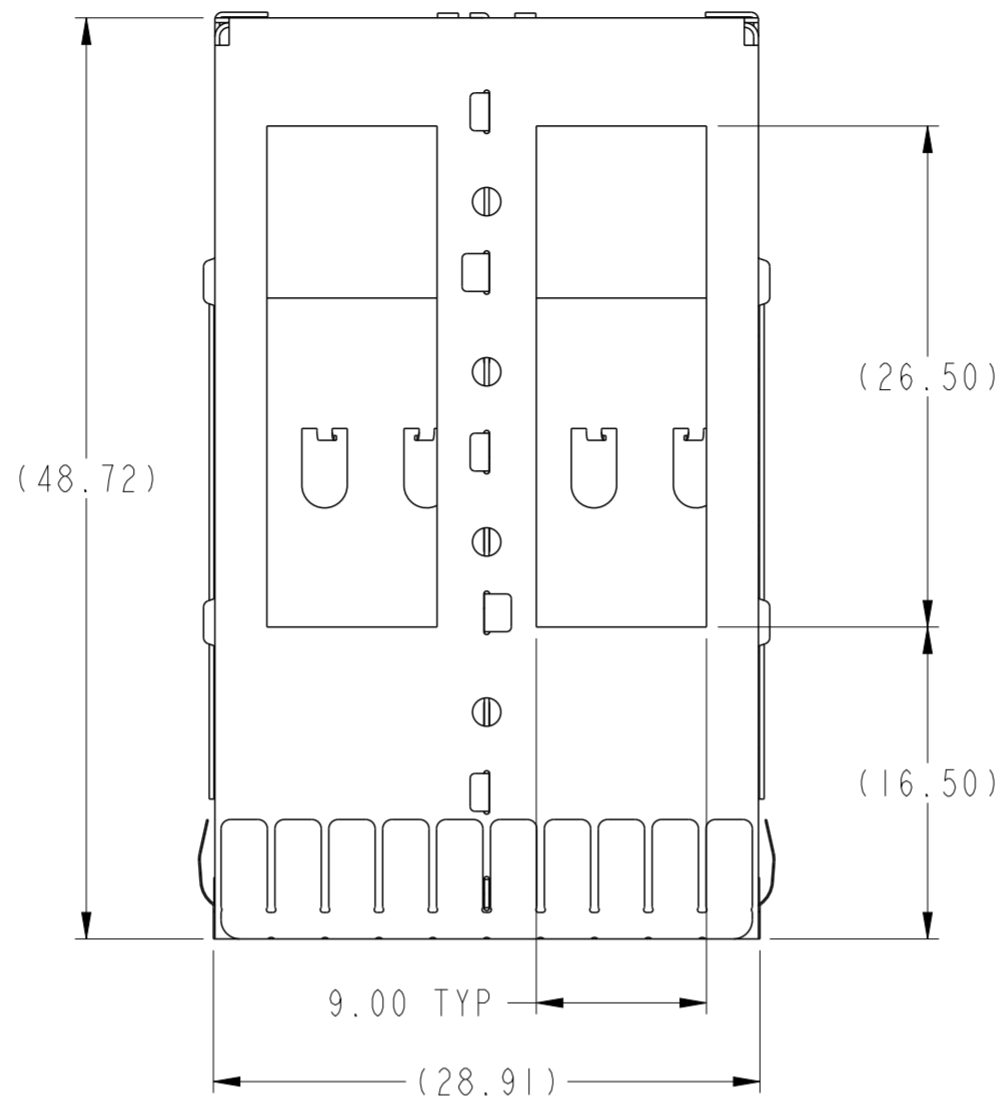
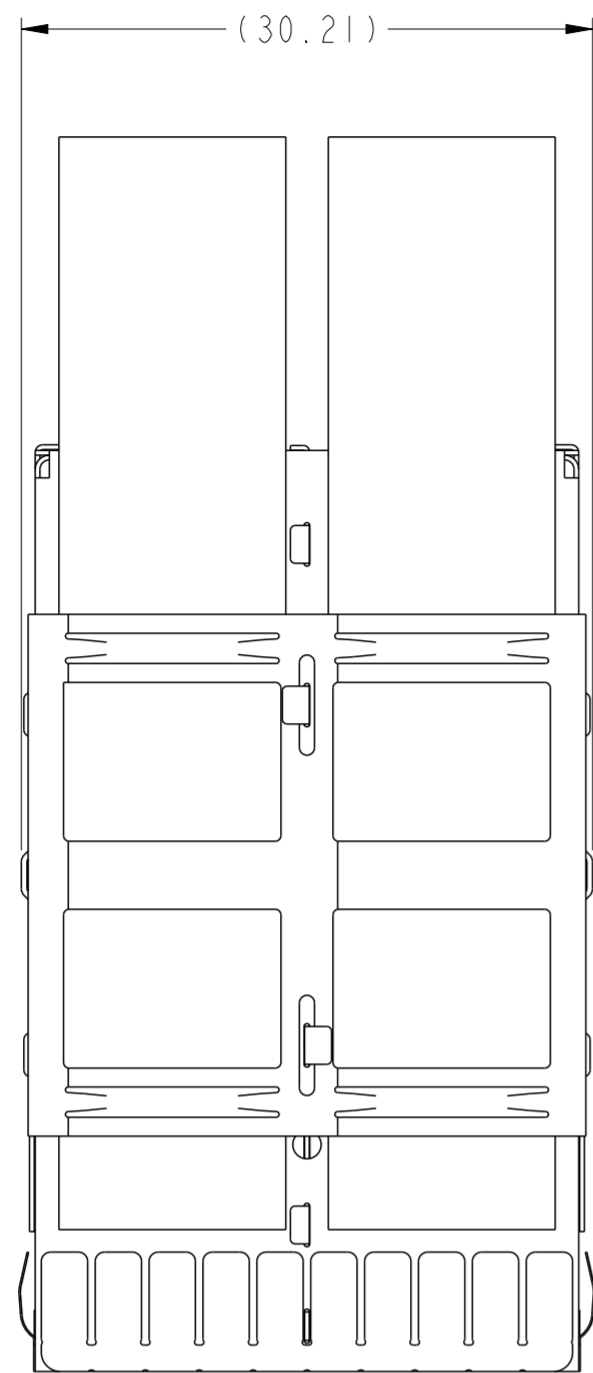

ASSEMBLY VIEW
SCALE 5:2

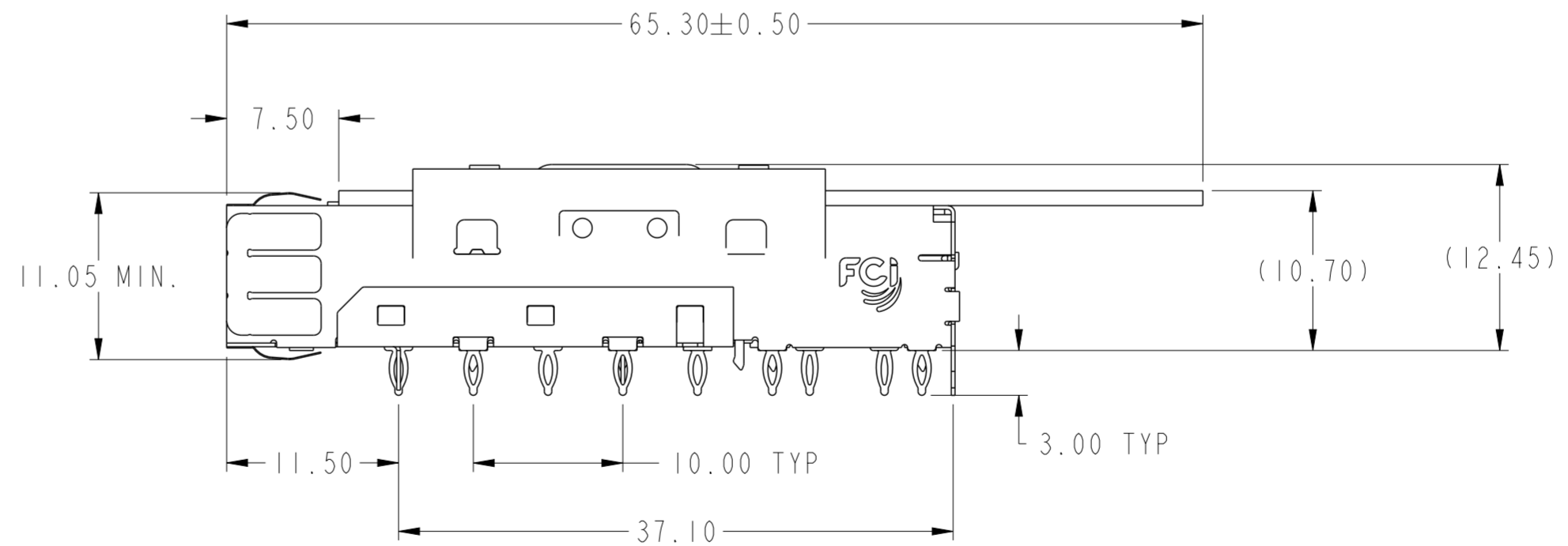
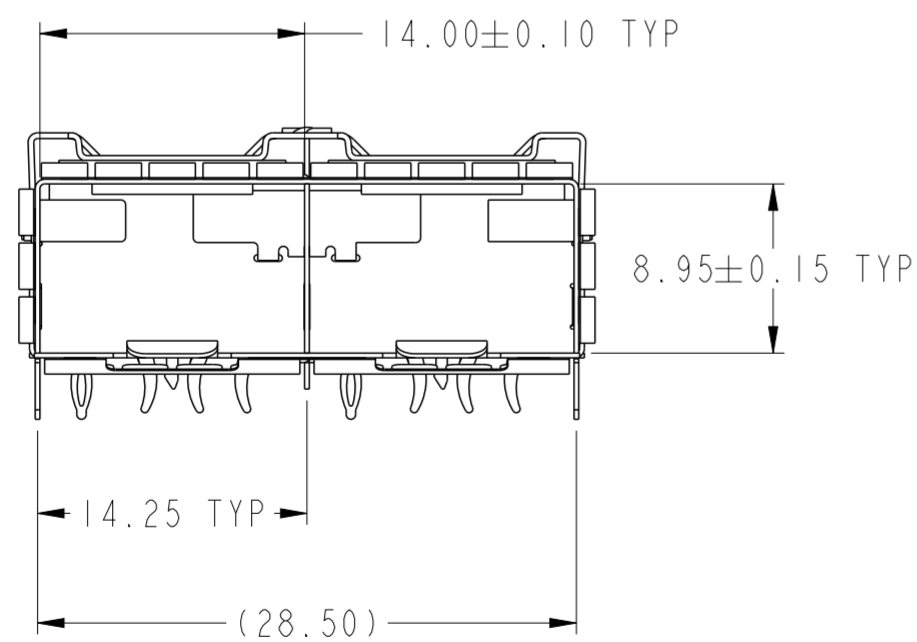

Copyright FCI.
FCI

spec ref	dr	Art Lin	2014/04/21	projection	mm	size	A2	scale	1:1
tolerance std	eng	Art Lin	2015/02/09		mm	ecn no	-	rel level	Released
ISO 406	chr	-	product family						
ISO 1101	appr	Collins Lu	2015/02/09			SFP+ 1X2 CAGE ASSEMBLY LOW PROFILE, SPRING FINGER		dwg no 10128841	rev A
surface	linear	0.X	±0.25	www.fci.com		cat. no.		Product - Customer Drw	
		0.XX	±0.15					sheet 3 of 11	
		0.XXX	±0.05						
ISO 1302	angular	0°	±1°						

Product Number	Packaging
10128841-103LF	Tray

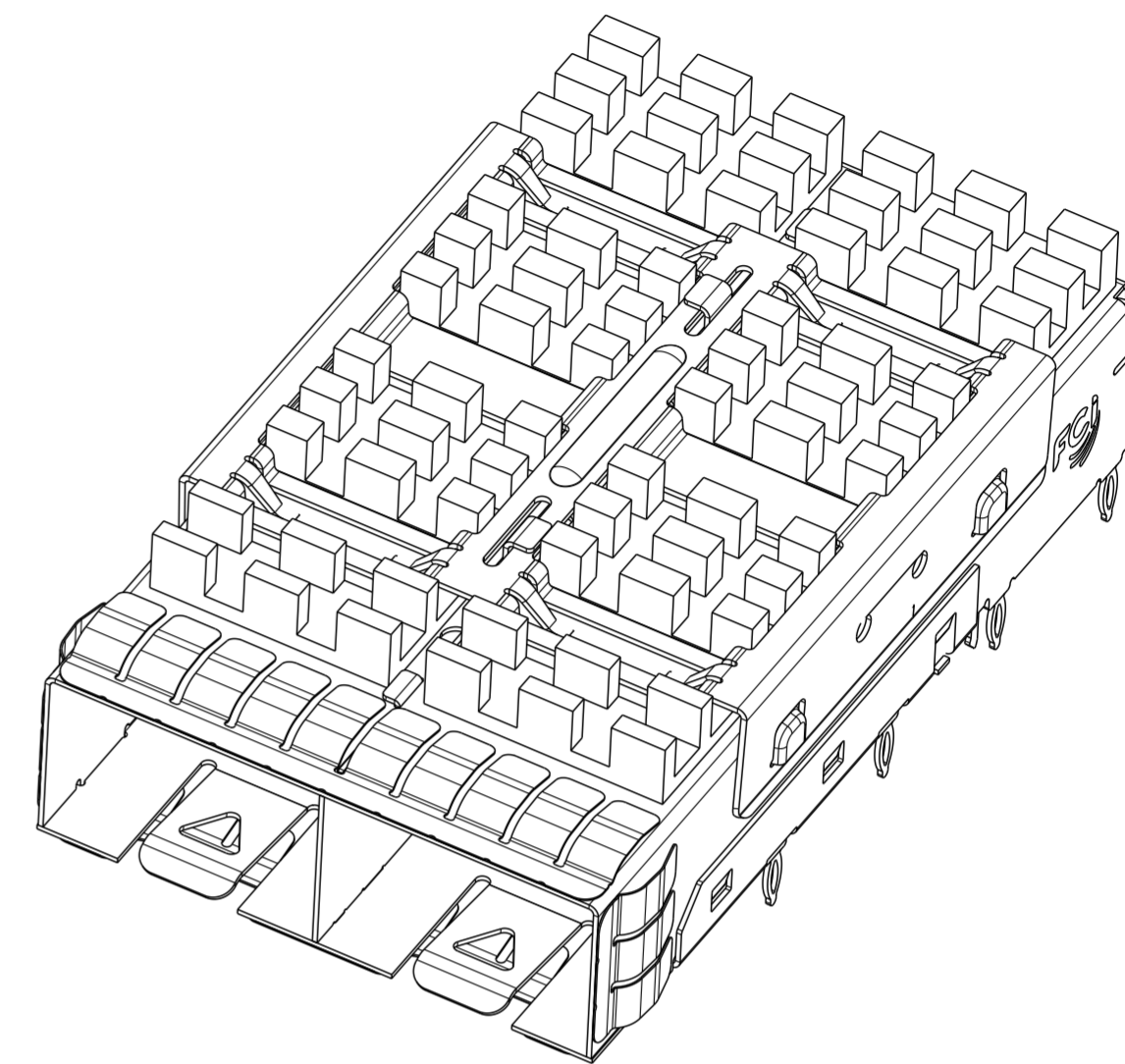
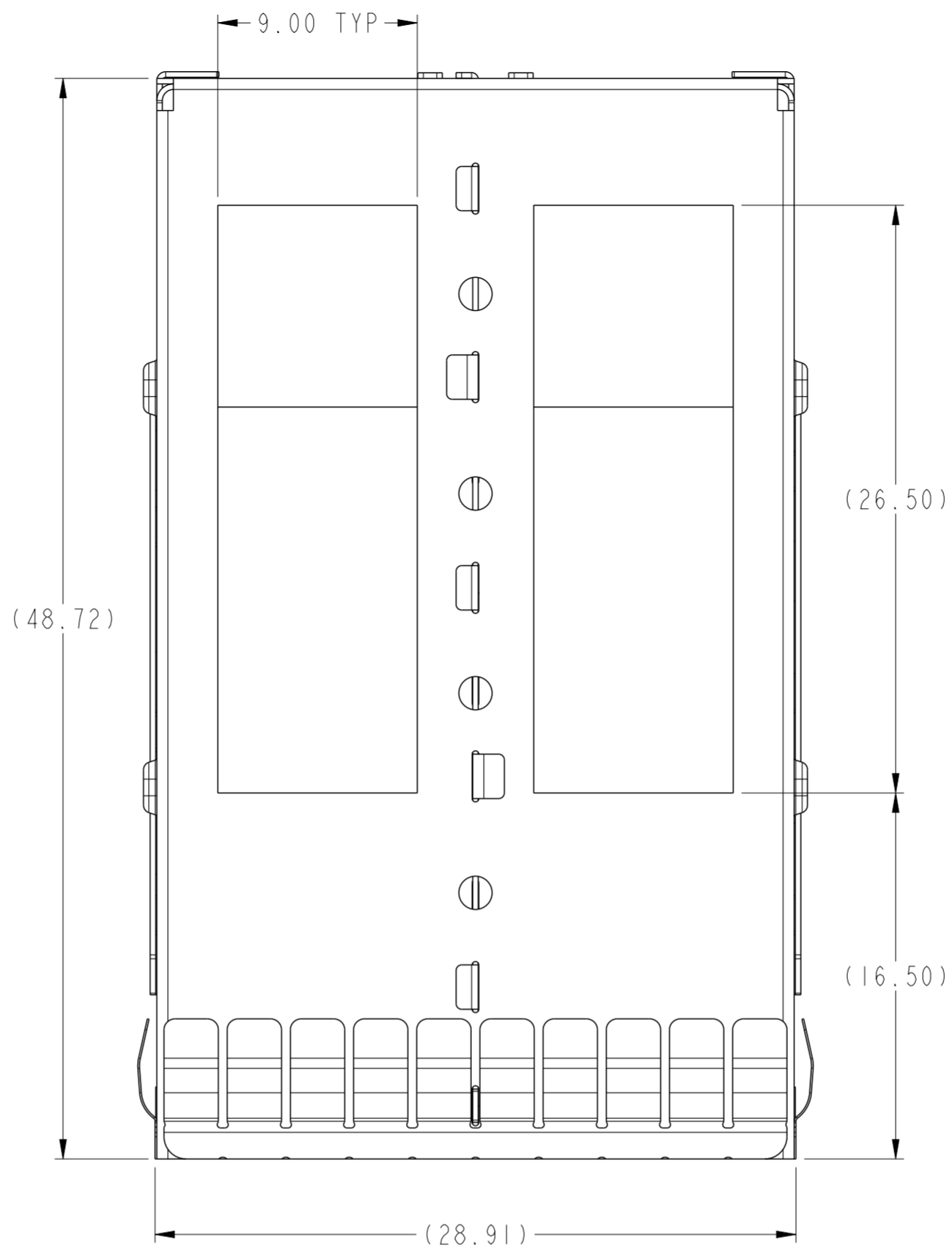
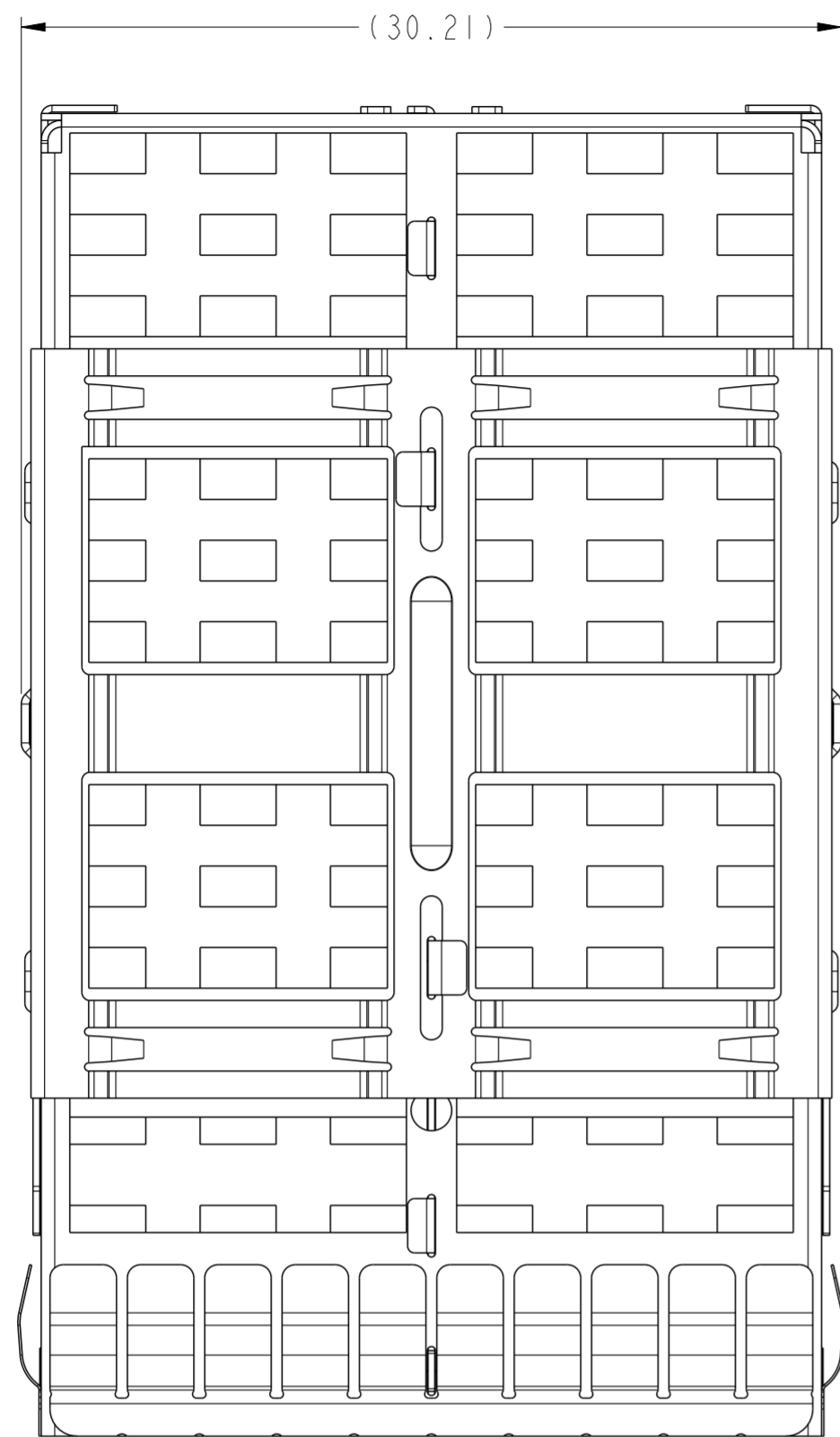

CAGE ASSEMBLY
SCALE 3:1

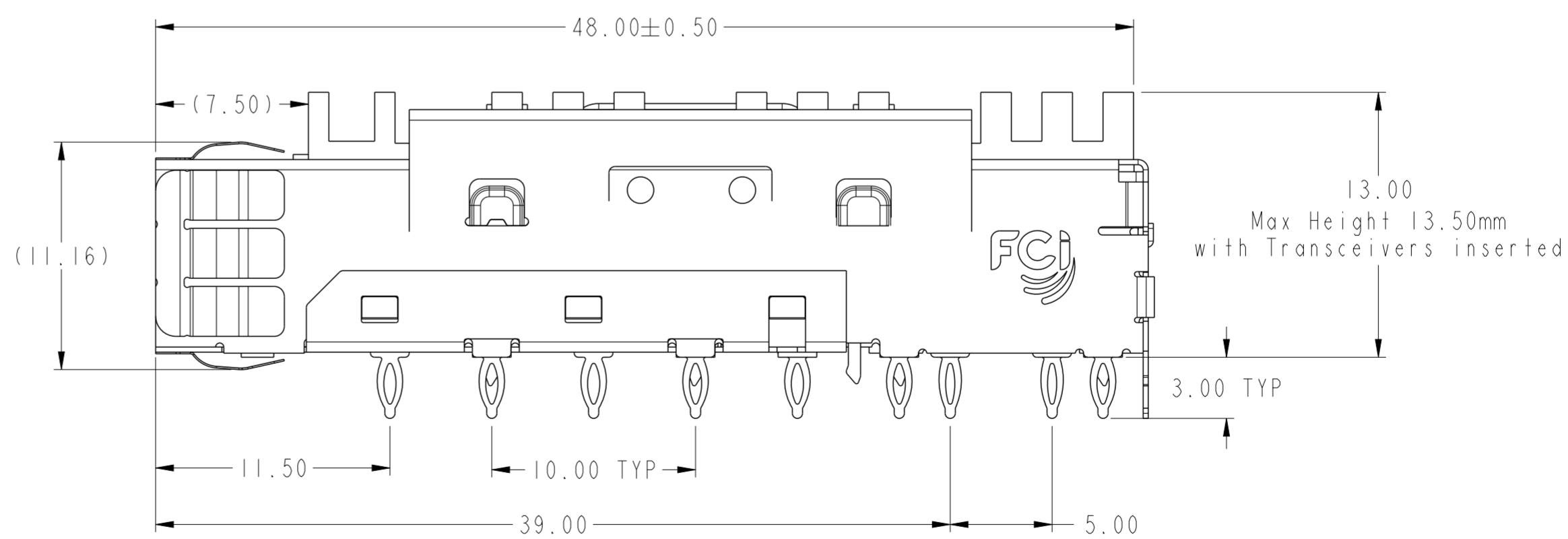
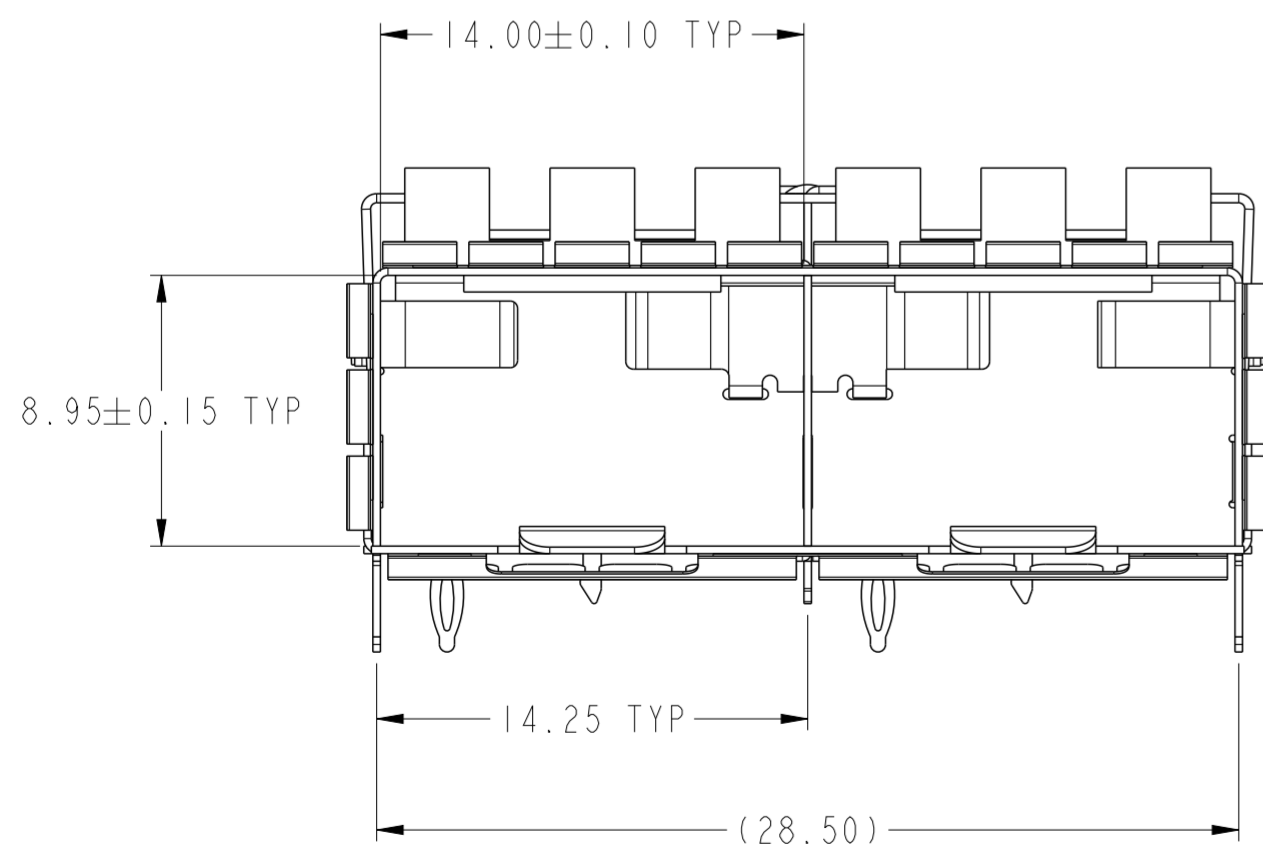

Copyright FCI.

spec ref	dr	Art Lin	2014/04/21	projection	mm	size	A2	scale	1:1
tolerance std	eng	Art Lin	2015/02/09		mm	ecn no	-	rel level	Released
ISO 406	chr	-	product family						
ISO 1101	appr	Collins Lu	2015/02/09			cat. no.	-	Product - Customer Draw	sheet 4 of 11
surface	linear	0.X	±0.25			title	SFP+ 1X2 CAGE ASSEMBLY	dwg no	10128841
		0.XX	±0.15	www.fci.com		rev	LOW PROFILE, SPRING FINGER		A
	angular	0°	±1°						

Product Number	Packaging
10128841-201LF	Tray

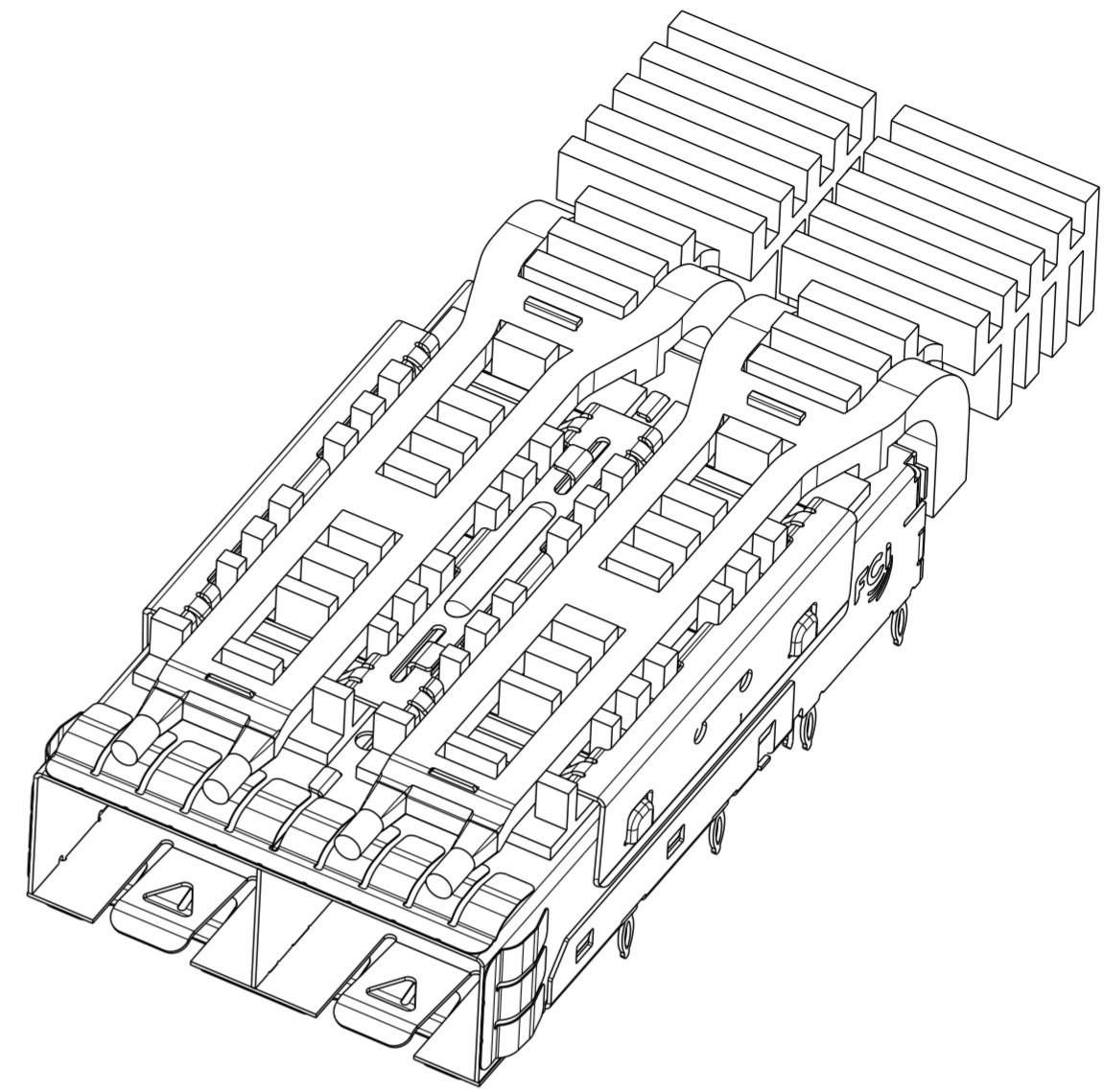
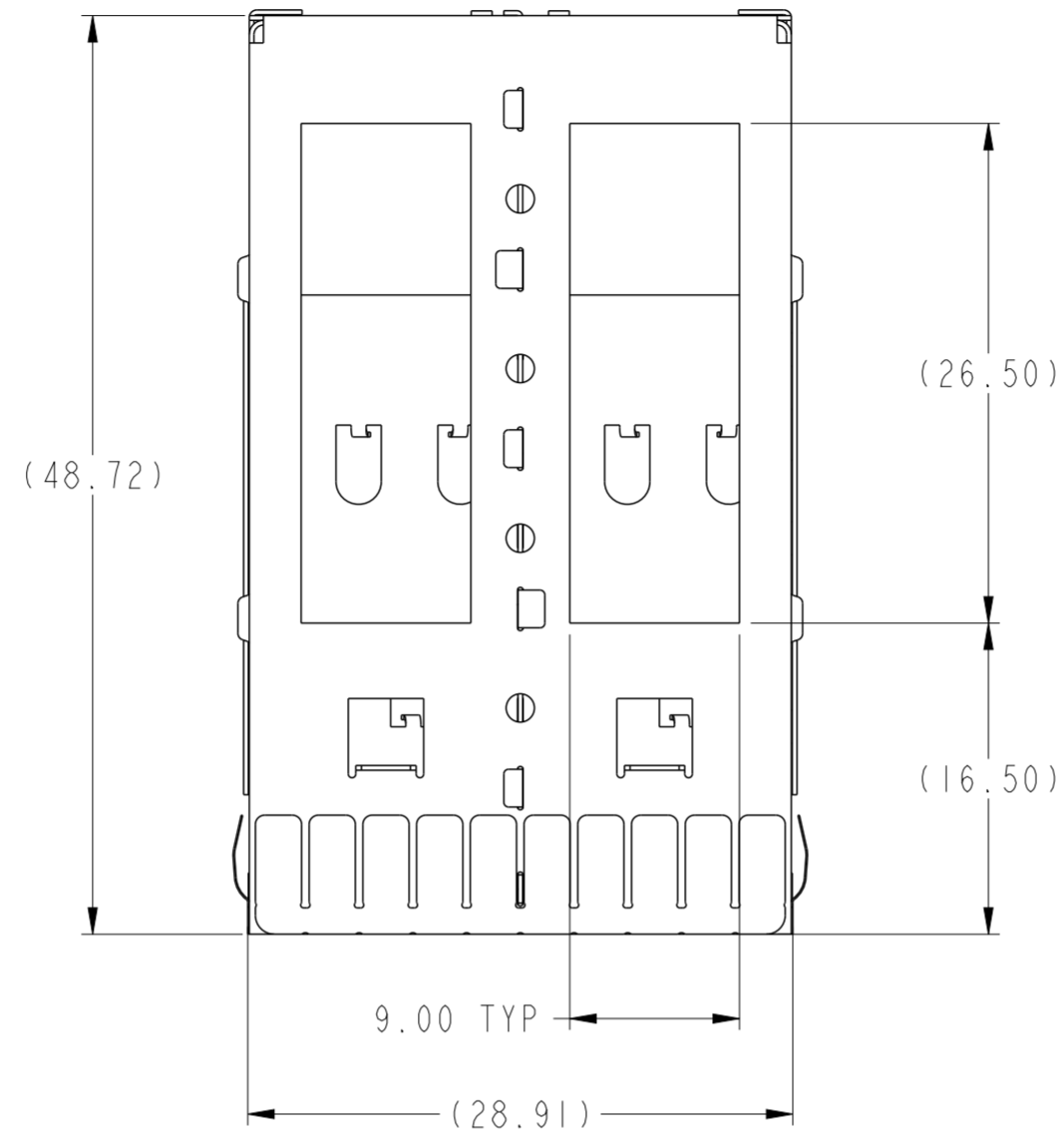
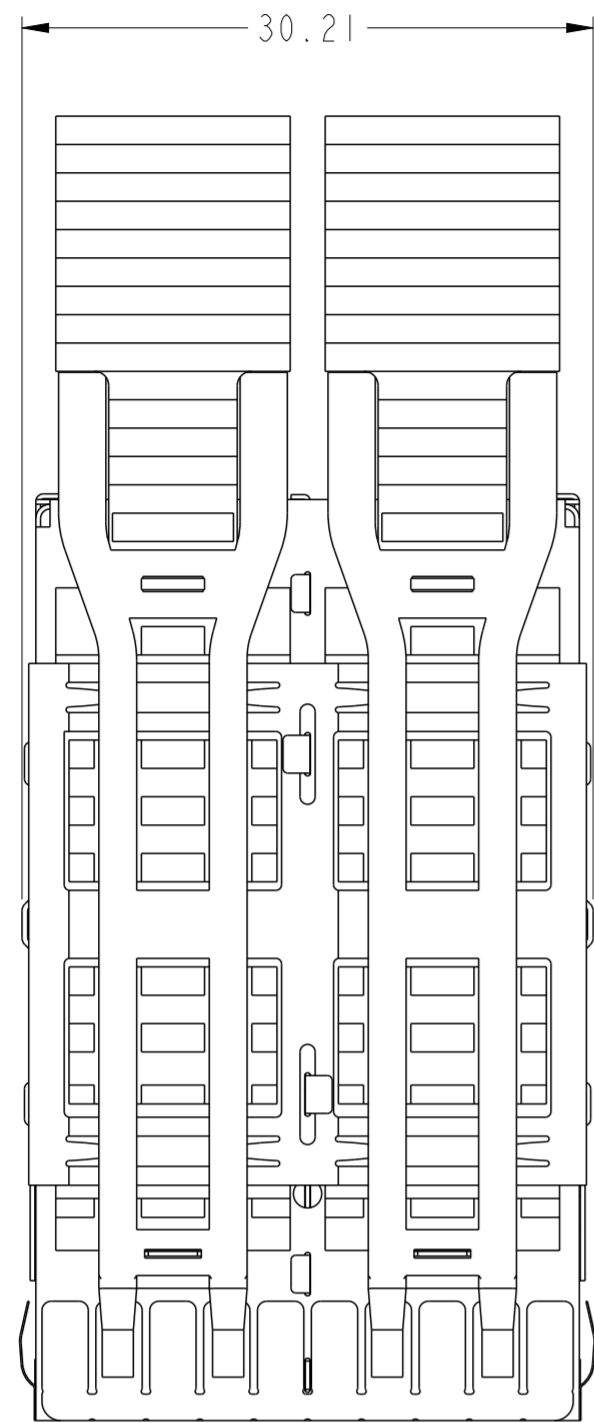

ASSEMBLY VIEW
SCALE 5:2

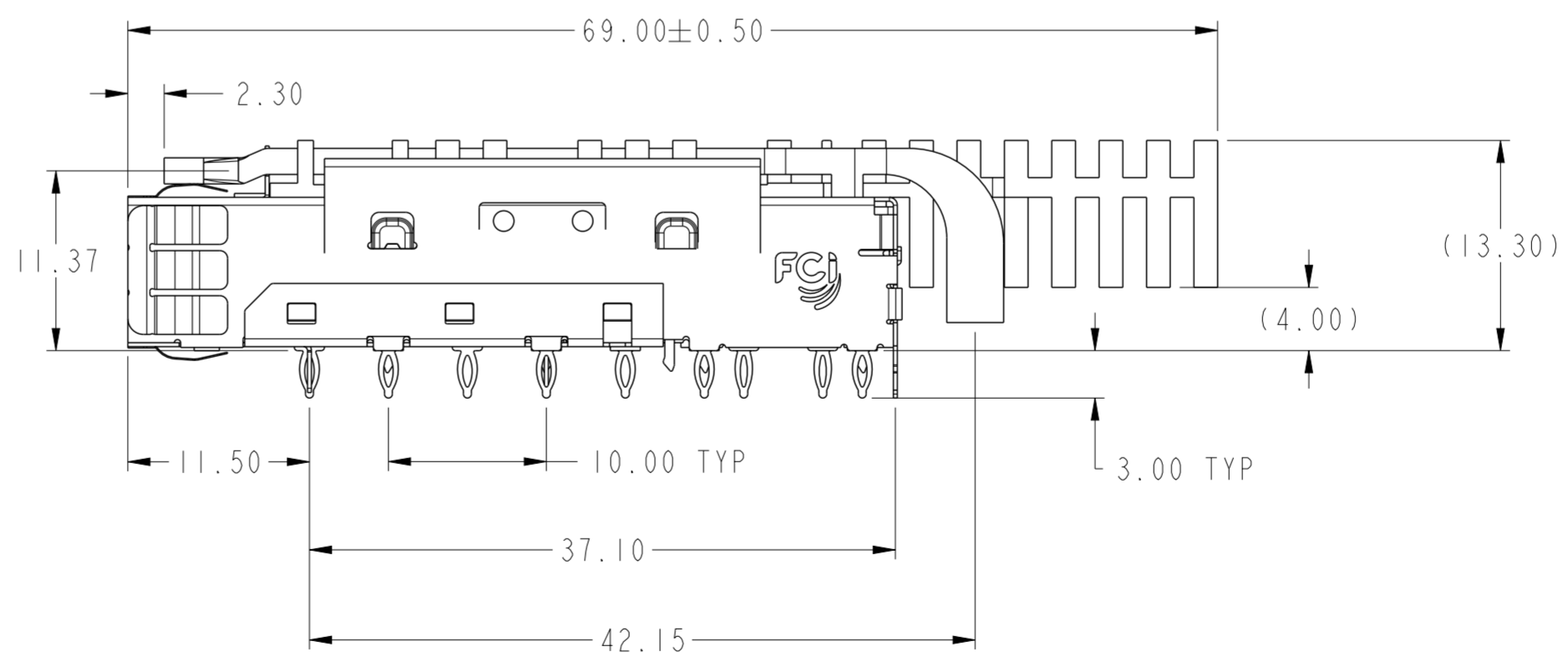
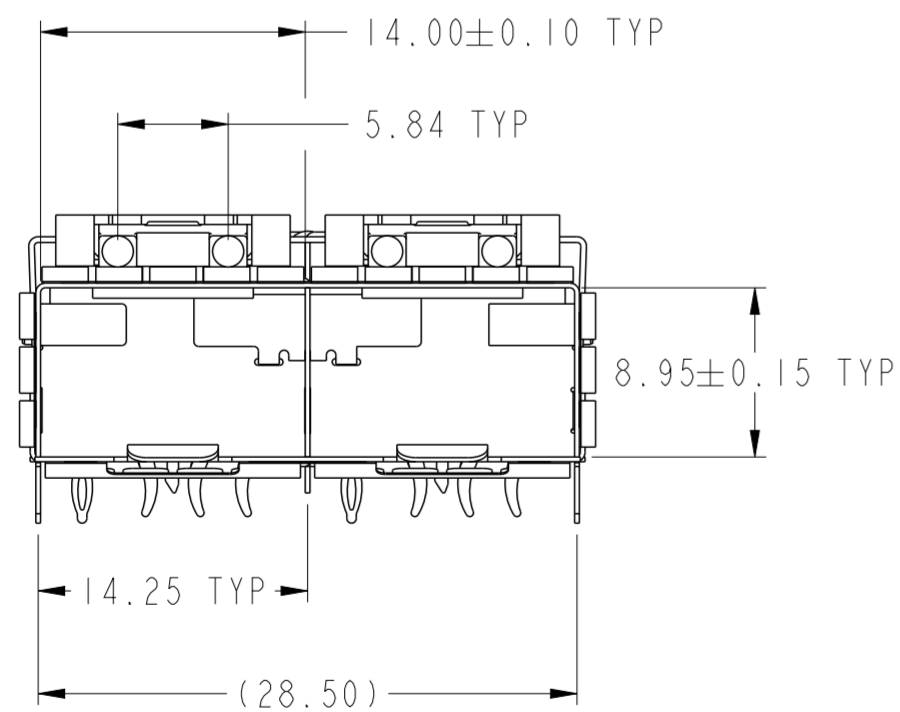

Copyright FCI.

spec ref	dr	Art Lin	2014/04/21	projection	mm	size	A2	scale	5:2
tolerance std	eng	Art Lin	2015/02/09		mm	ecn no	-	rel level	Released
ISO 406	chr	-	product family						
ISO 1101	appr	Collins Lu	2015/02/09			SFP+ 1X2 CAGE ASSEMBLY LOW PROFILE, SPRING FINGER		dwg no 10128841	rev A
surface	linear	0.X	±0.25	www.fci.com		cat. no.		Product - Customer Drw	
		0.XX	±0.15					sheet 5 of 11	
		0.XXX	±0.05						
ISO 1302	angular	0°	±1°						

Product Number	Packaging
10128841-211LF	Tray

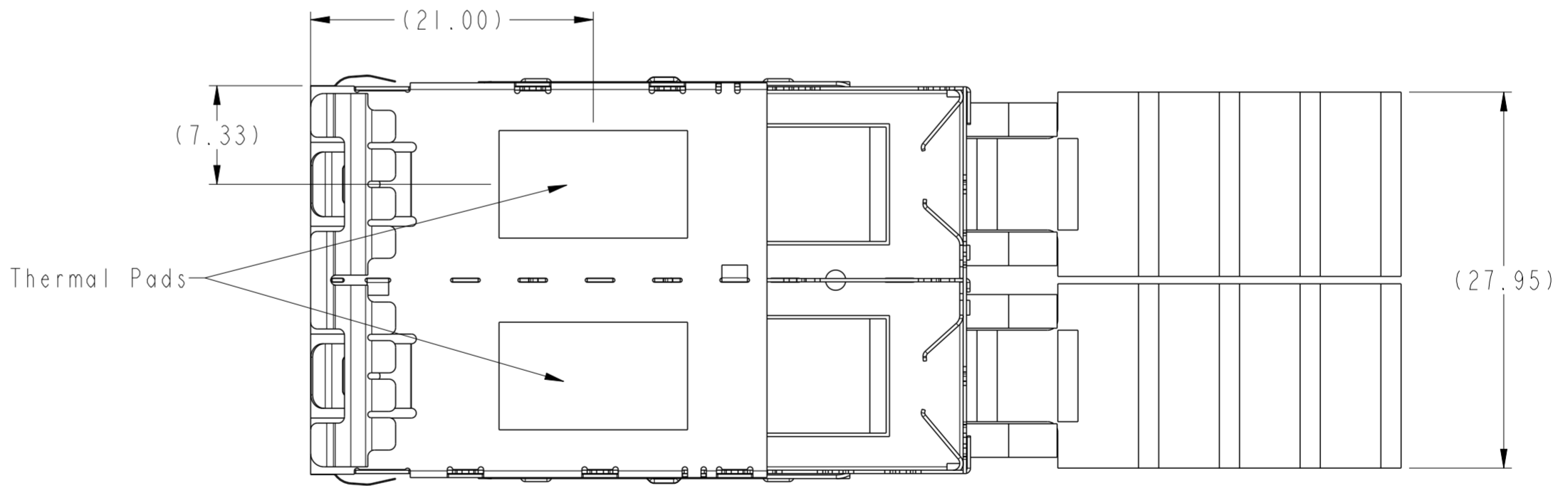
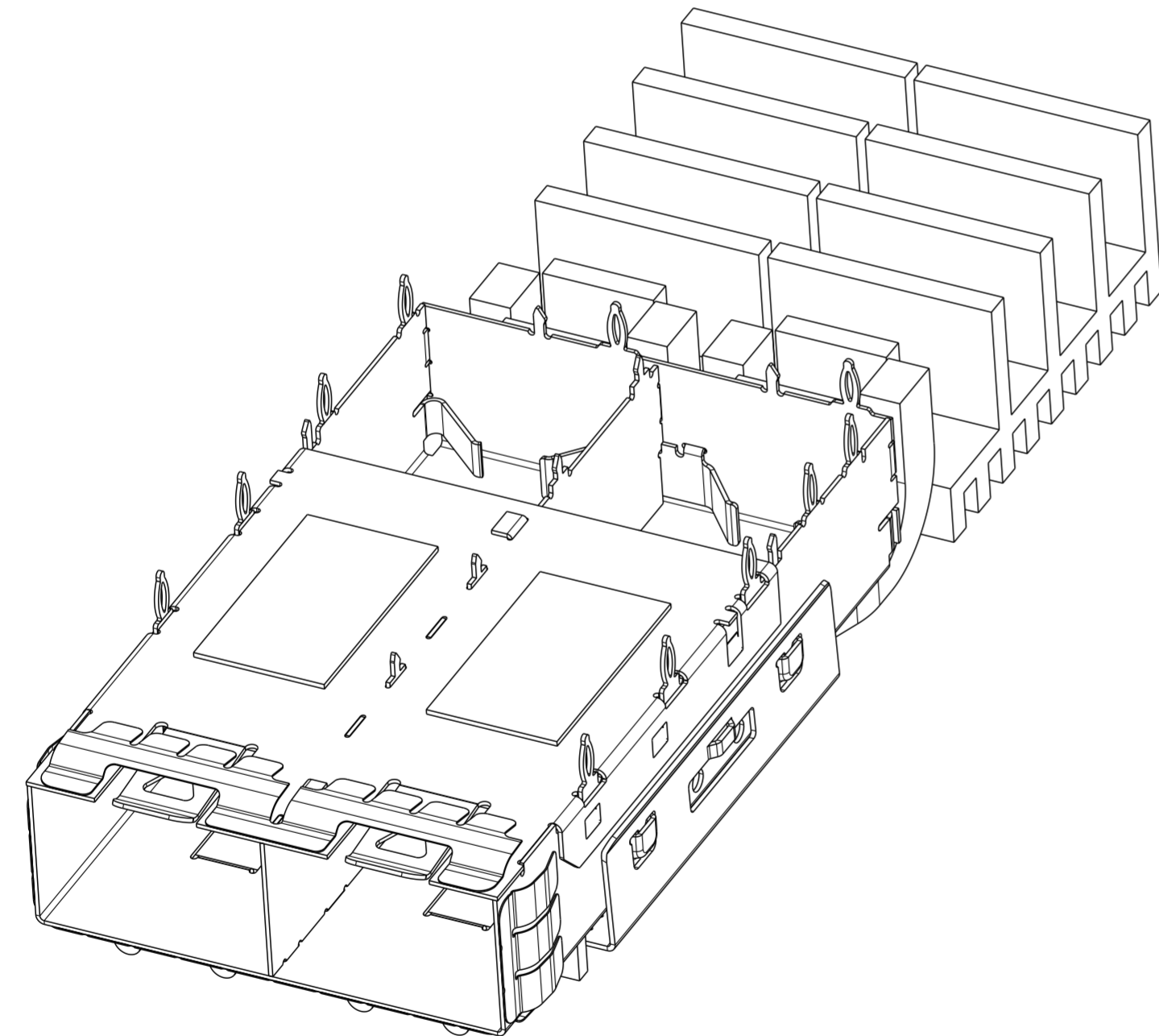
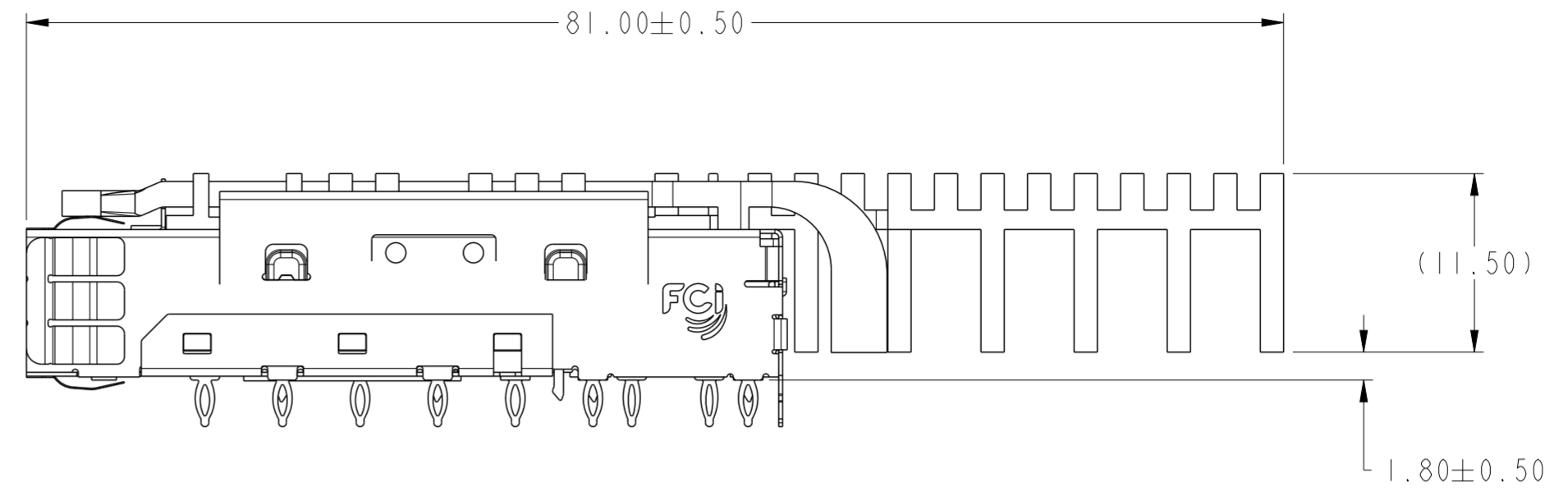
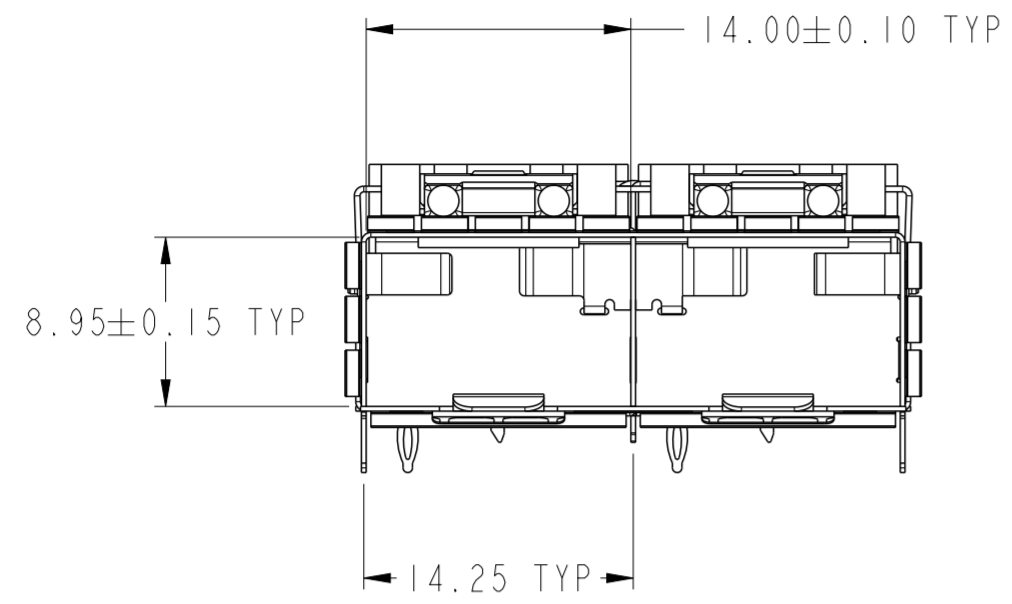

THE OTHER DIMENSIONS OF 10128841-211LF ARE SAME TO 10128841-201LF

SCALE 3:1

Copyright FCI.

spec ref	dr	Art Lin	2014/04/21	projection	mm	size	A2	scale	1:1
tolerance std	eng	Art Lin	2015/02/09		mm	ecn no	-	rel level	Released
ISO 406	chr	-	product family						
ISO 1101	appr	Collins Lu	2015/02/09			cat. no.	-	Product - Customer Drw	sheet 6 of 11
surface	linear	0.X	±0.25	SFP+ 1X2 CAGE ASSEMBLY LOW PROFILE, SPRING FINGER		dwg no	10128841	rev	A
ISO 1302	angular	0°	±1°	www.fci.com					

PDS: Rev :A

STATUS:Released

Printed: Feb 09, 2015

Product Number	Packaging
10128841-212LF	Tray

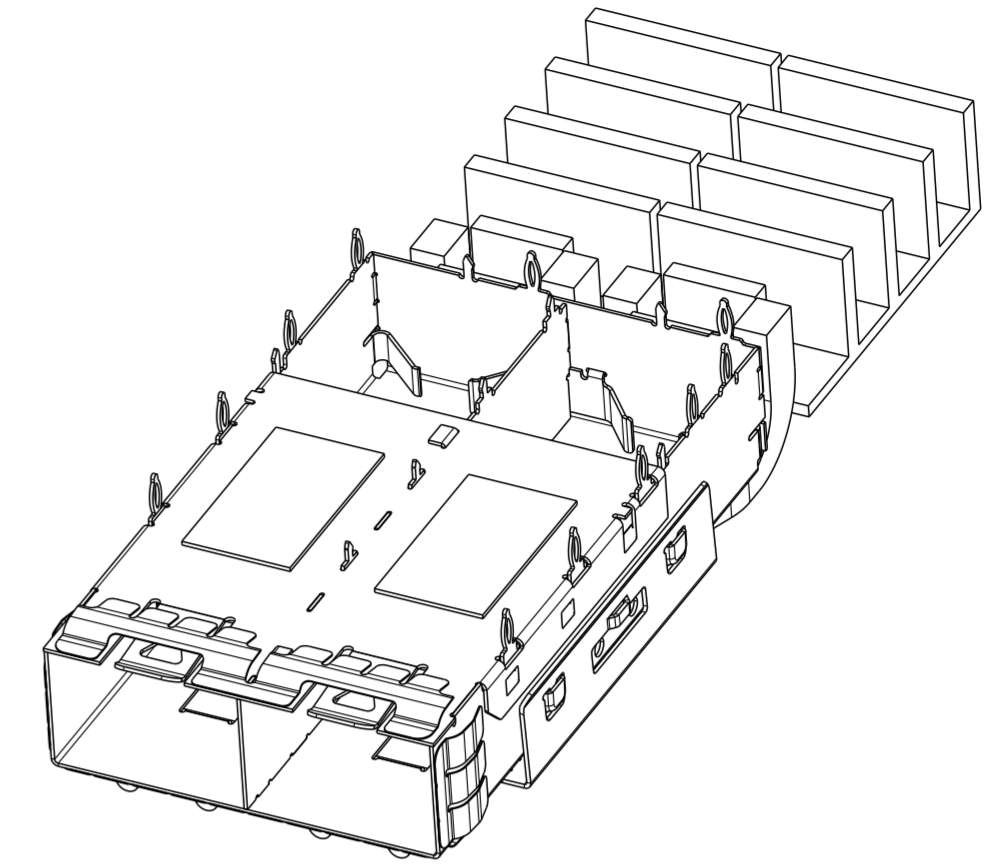
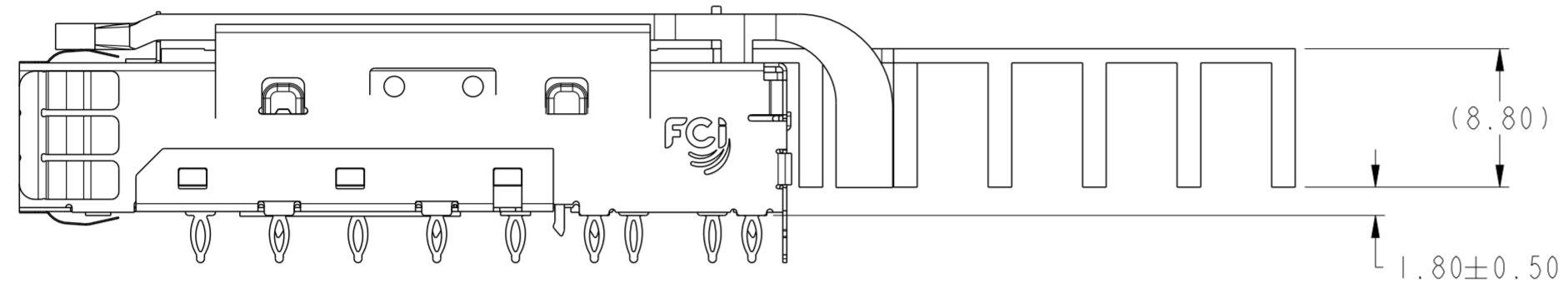

SCALE 2:1

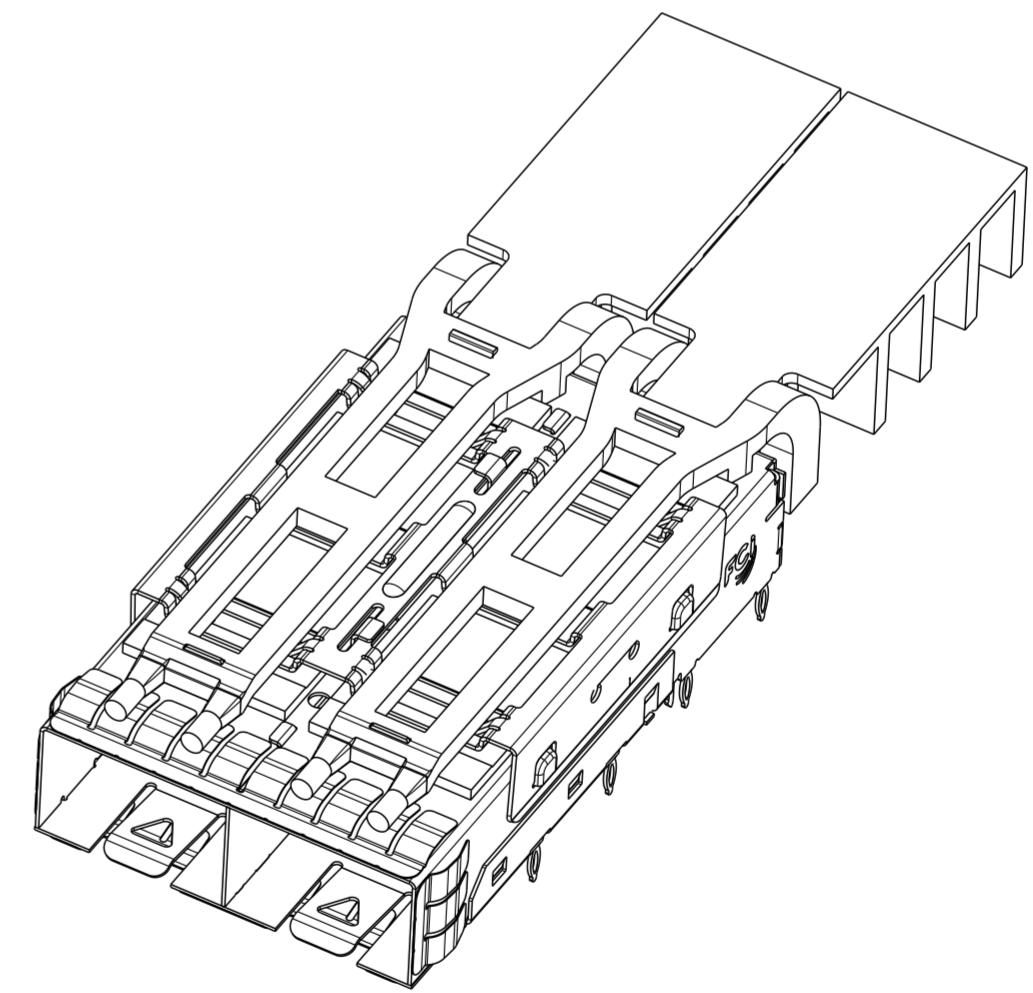
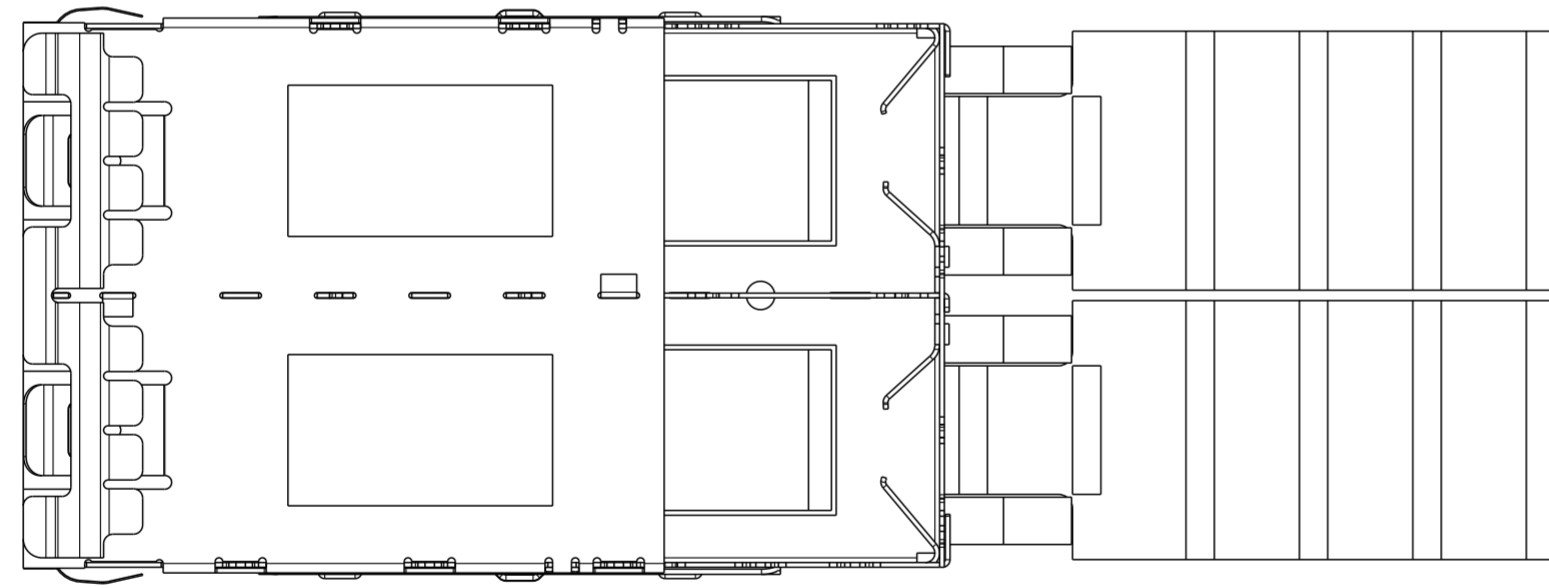

SCALE 2:1

THE OTHER DIMENSIONS OF 10128841-212LF ARE SAME TO 10128841-211LF

Copyright FCI. FCI

spec ref	dr	Art Lin	2014/04/21	projection	mm	size	A2	scale	1:1
tolerance std	eng	Art Lin	2015/02/09			ecn no	-	rel level	Released
ISO 406 ISO 1101	chr	-	product family						
surface ✓ ISO 1302	linear angular	0.X	±0.25		title SFP+ 1X2 CAGE ASSEMBLY LOW PROFILE, SPRING FINGER	dwg no 10128841	rev A	Product - Customer Drw	
		0.XX	±0.15					sheet 7 of 11	
		0.XXX	±0.05						
ISO 1302	angular	0°	±1°	www.fci.com	cat. no.	-	Product - Customer Drw		sheet 7 of 11

PDS: Rev :A

STATUS:Released

Printed: Feb 09, 2015

Product Number	Packaging
10128841-213LF	Tray

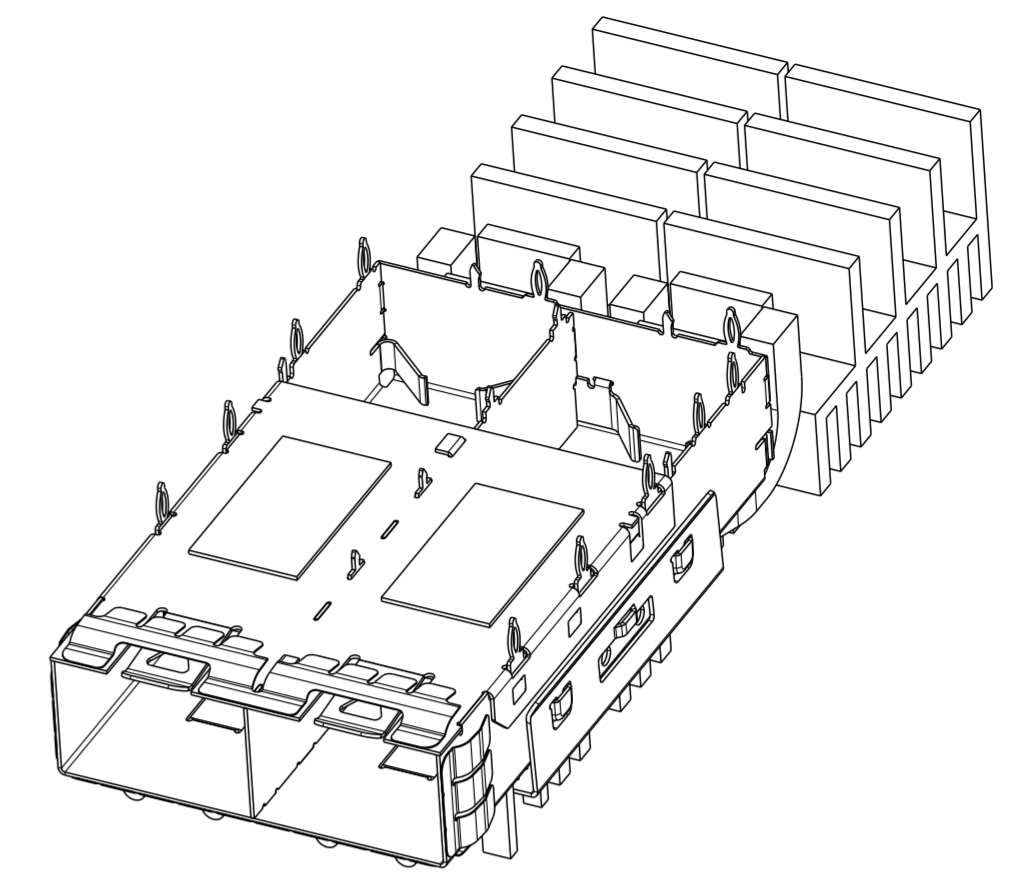
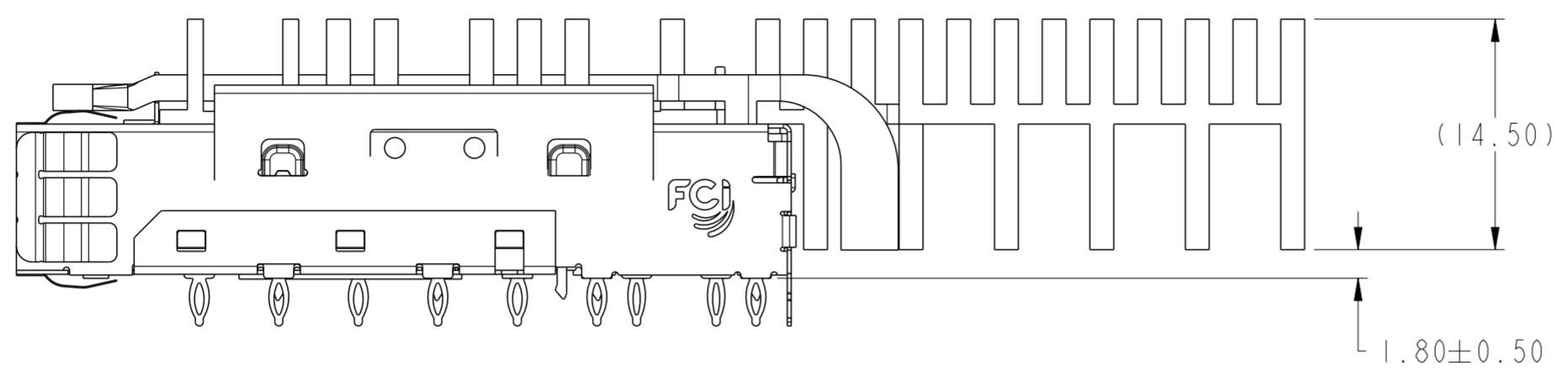

SCALE 2:1

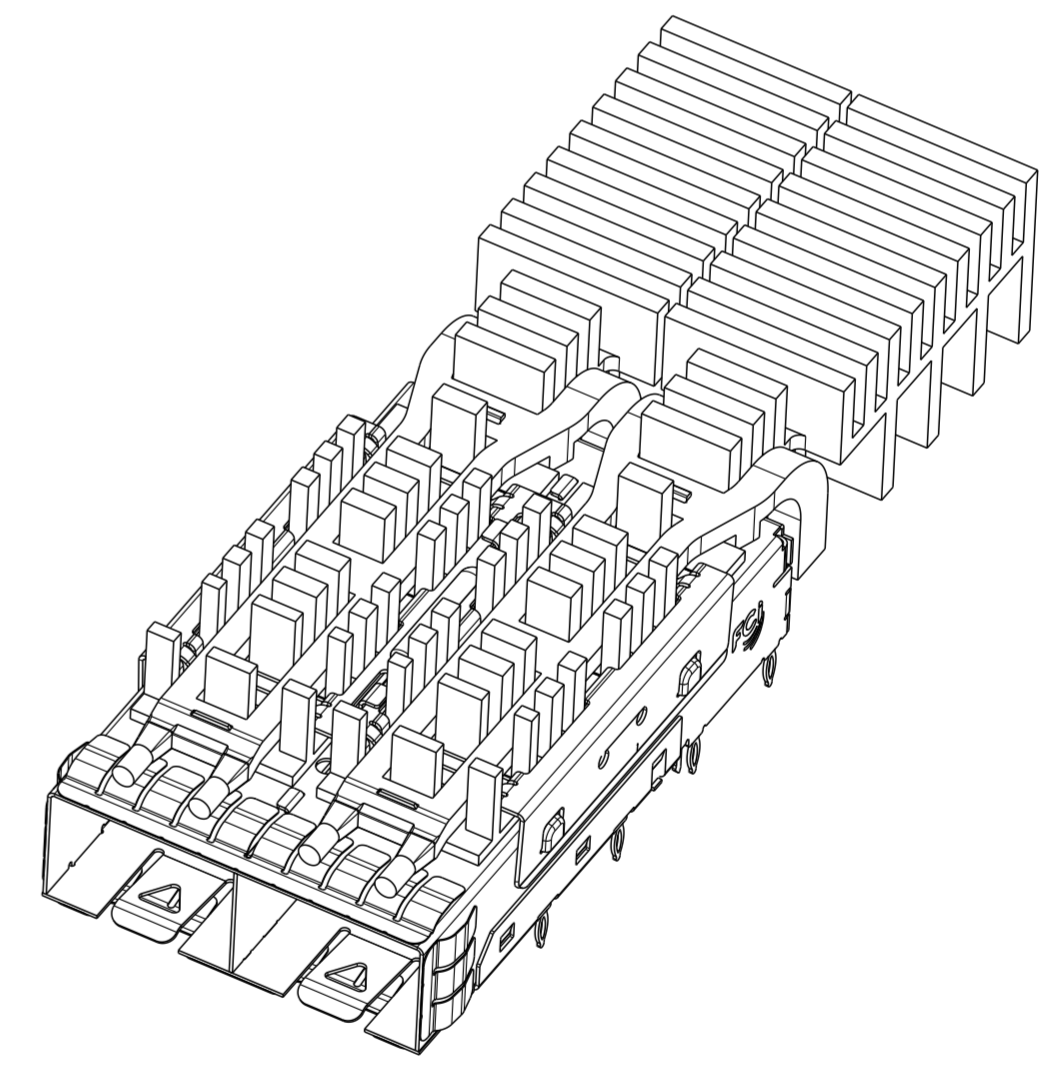
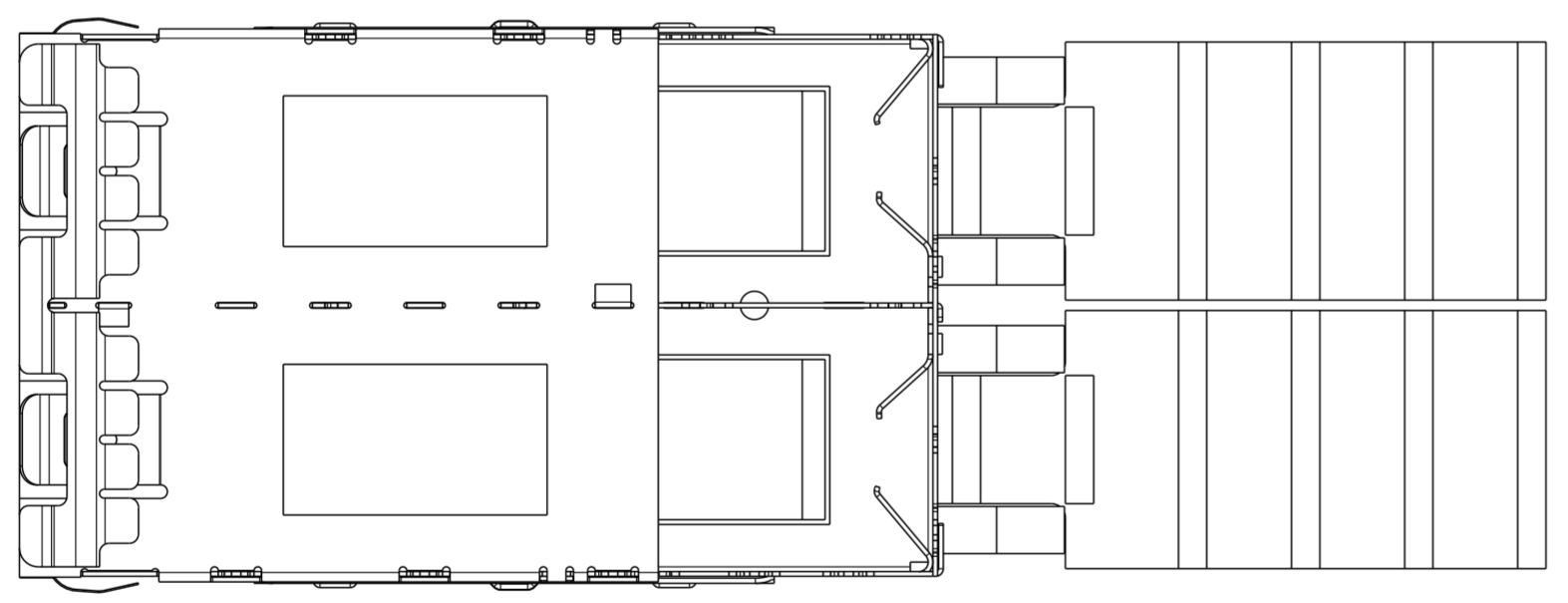

SCALE 2:1

THE OTHER DIMENSIONS OF 10128841-213LF ARE SAME TO 10128841-211LF

Copyright FCI. FCI

spec ref	dr	Art Lin	2014/04/21	projection	mm	size	A2	scale	1:1
tolerance std	eng	Art Lin	2015/02/09			ecn no	-	Released	rev A
ISO 406 ISO 1101	chr	-	product family			-	rel level		
surface	appr	Collins Lu	2015/02/09			SFP+ 1X2 CAGE ASSEMBLY LOW PROFILE, SPRING FINGER		cat. no. 10128841	sheet 8 of 11
ISO 1302	linear	0.X	±0.25	www.fci.com		Product - Customer Draw		Printed: Feb 09, 2015	
	angular	0°	±1°	PDS: Rev :A		STATUS:Released		Printed: Feb 09, 2015	

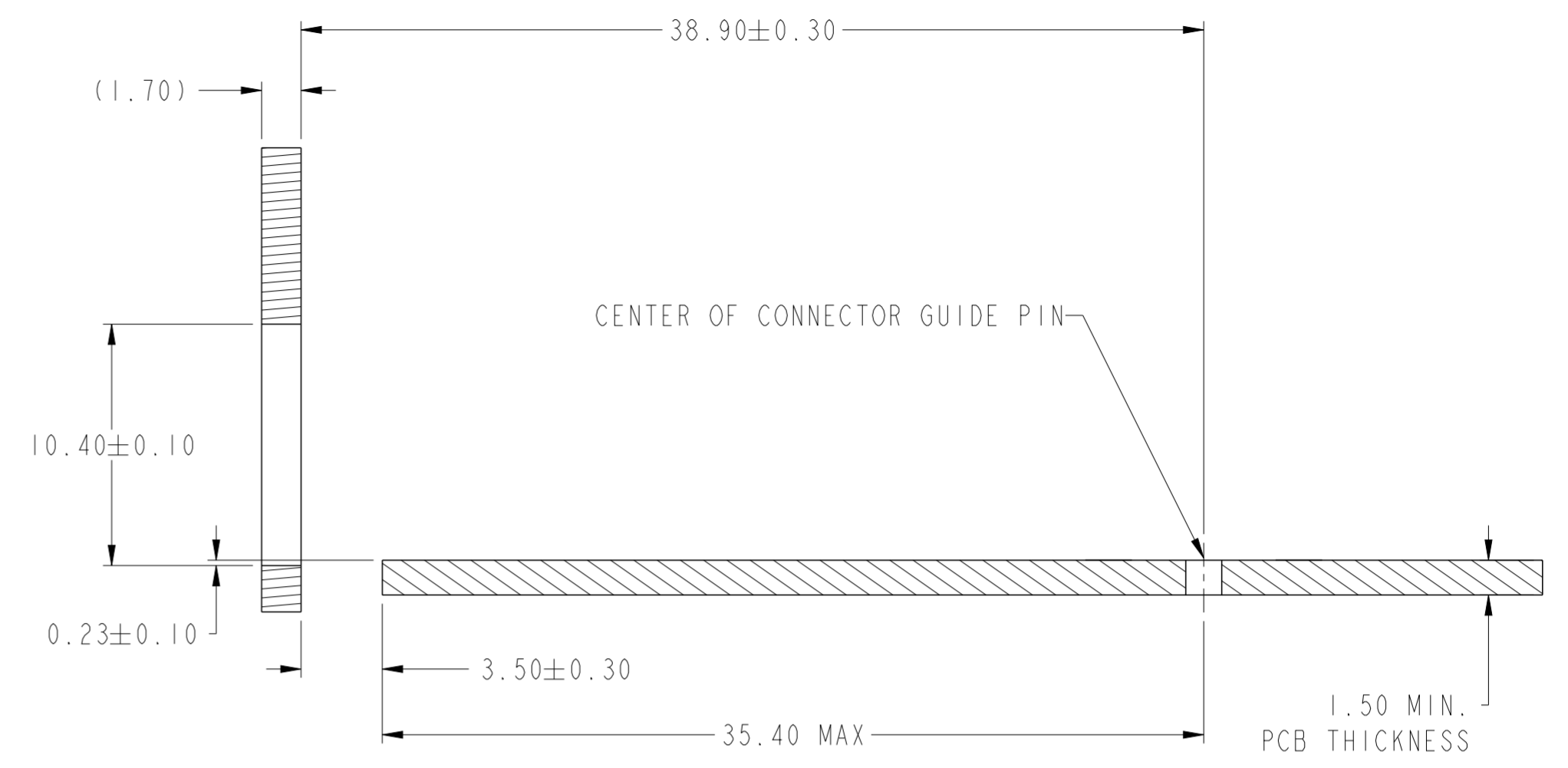
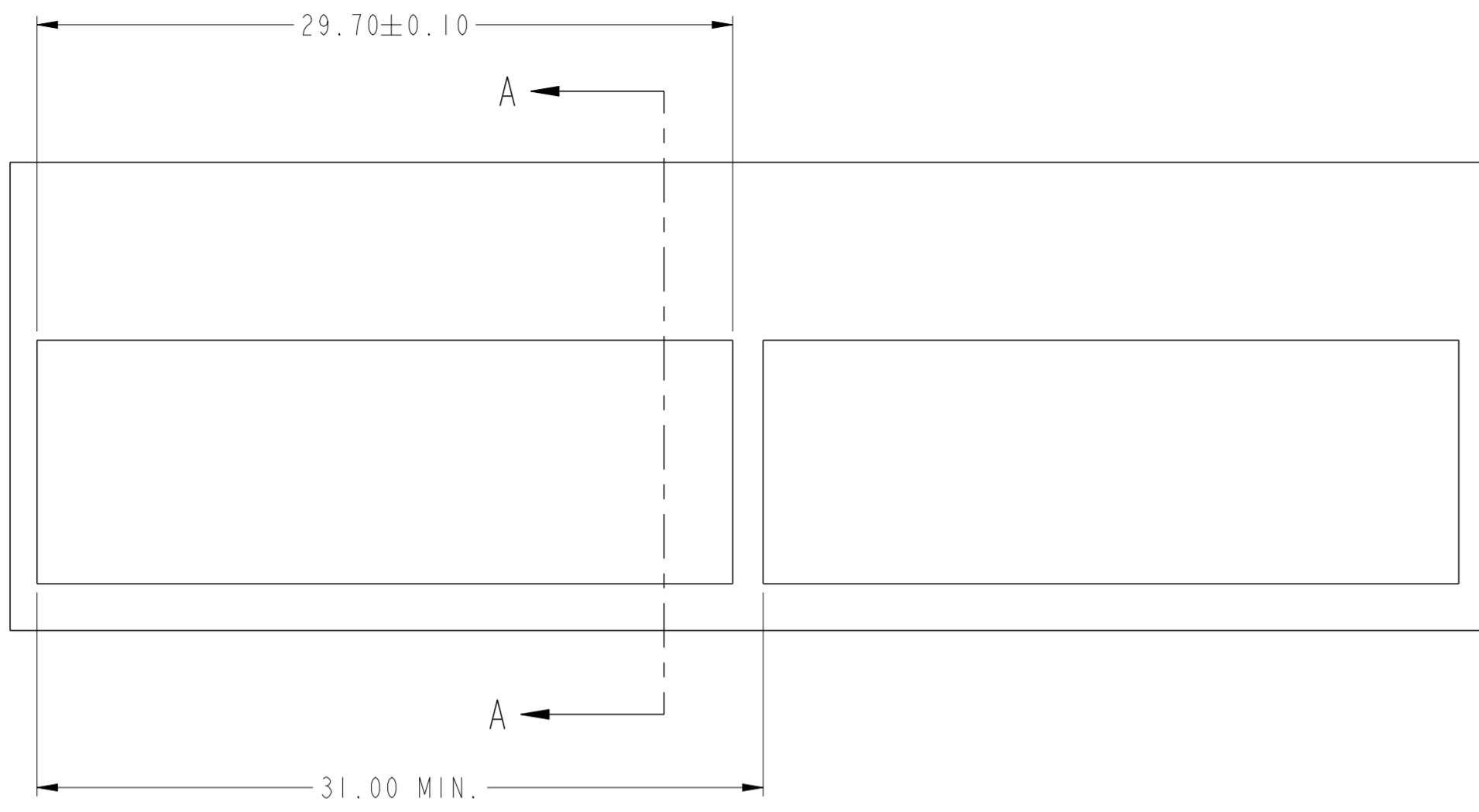

P/N: 10128841-001LF/002LF/101LF/102LF

SECTION A-A

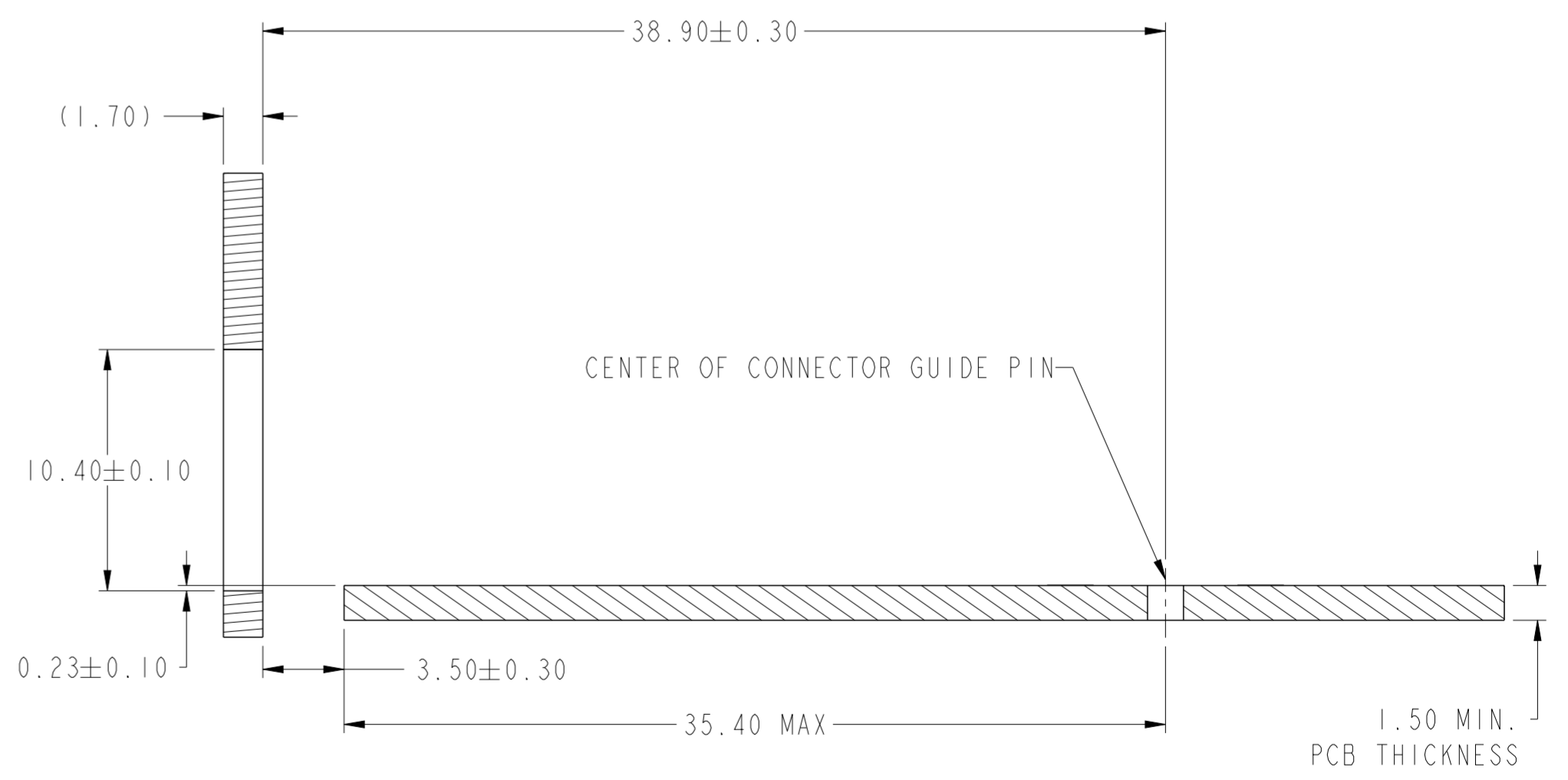
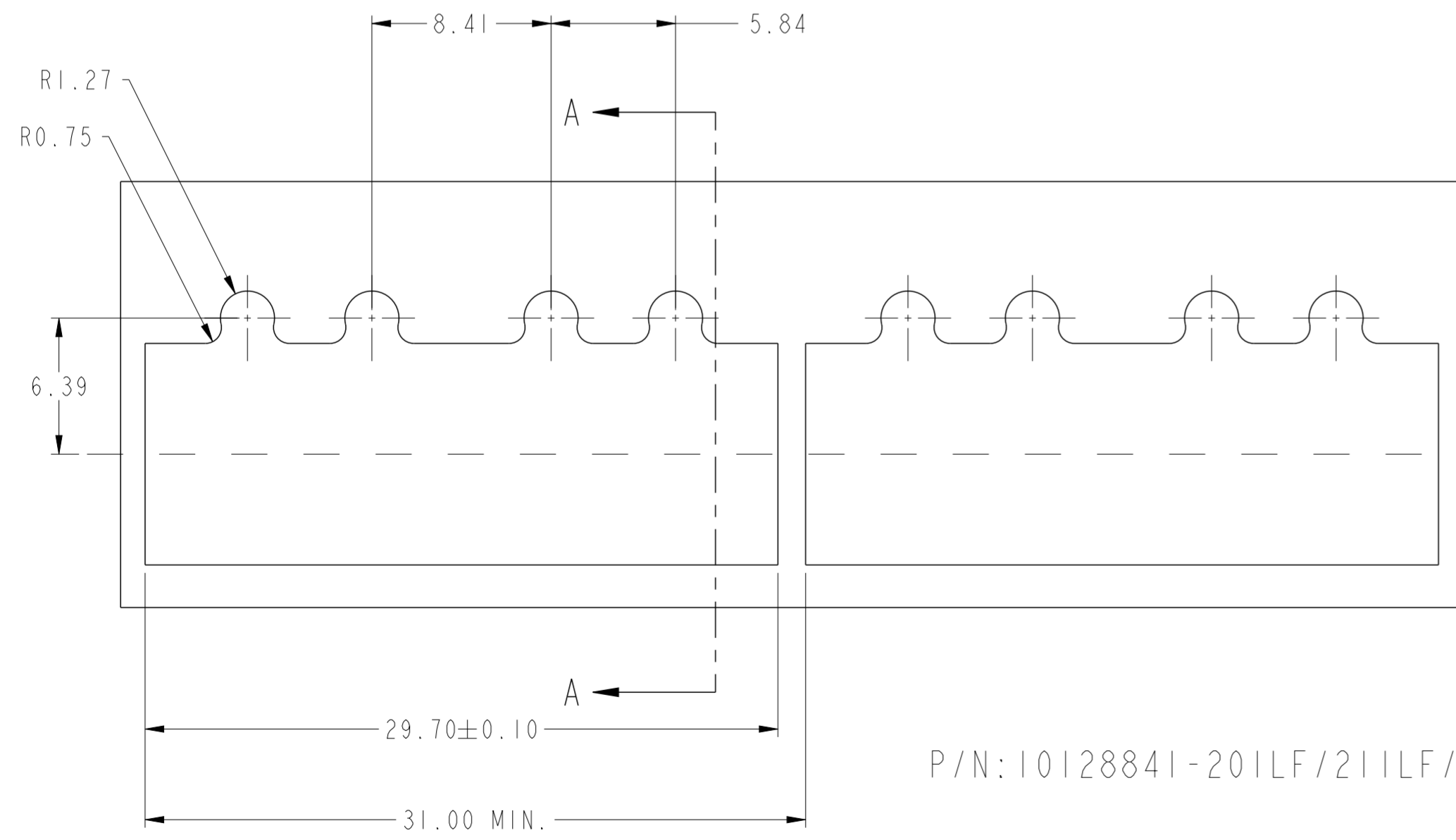

P/N: 10128841-201LF/211LF/212LF/213LF

SECTION A-A

spec ref	dr	Art Lin	2014/04/21	projection	mm	size	A2	scale	4:1
tolerance std	eng	Art Lin	2015/02/09		mm	ecn no	-	rel level	Released
ISO 406	chr	-							
ISO 1101	appr	Collins Lu	2015/02/09						
surface	linear	0.X	±0.25	product family	SFP+	rel level	Released	rev	A
ISO 1302	angular	0°	±1°	product family	SFP+	rel level	Released	rev	A
TOLERANCES UNLESS OTHERWISE SPECIFIED		www.fci.com		SFP+ 1X2 CAGE ASSEMBLY		10128841		sheet 9 of 11	
				LOW PROFILE, SPRING FINGER					

Copyright FCI.

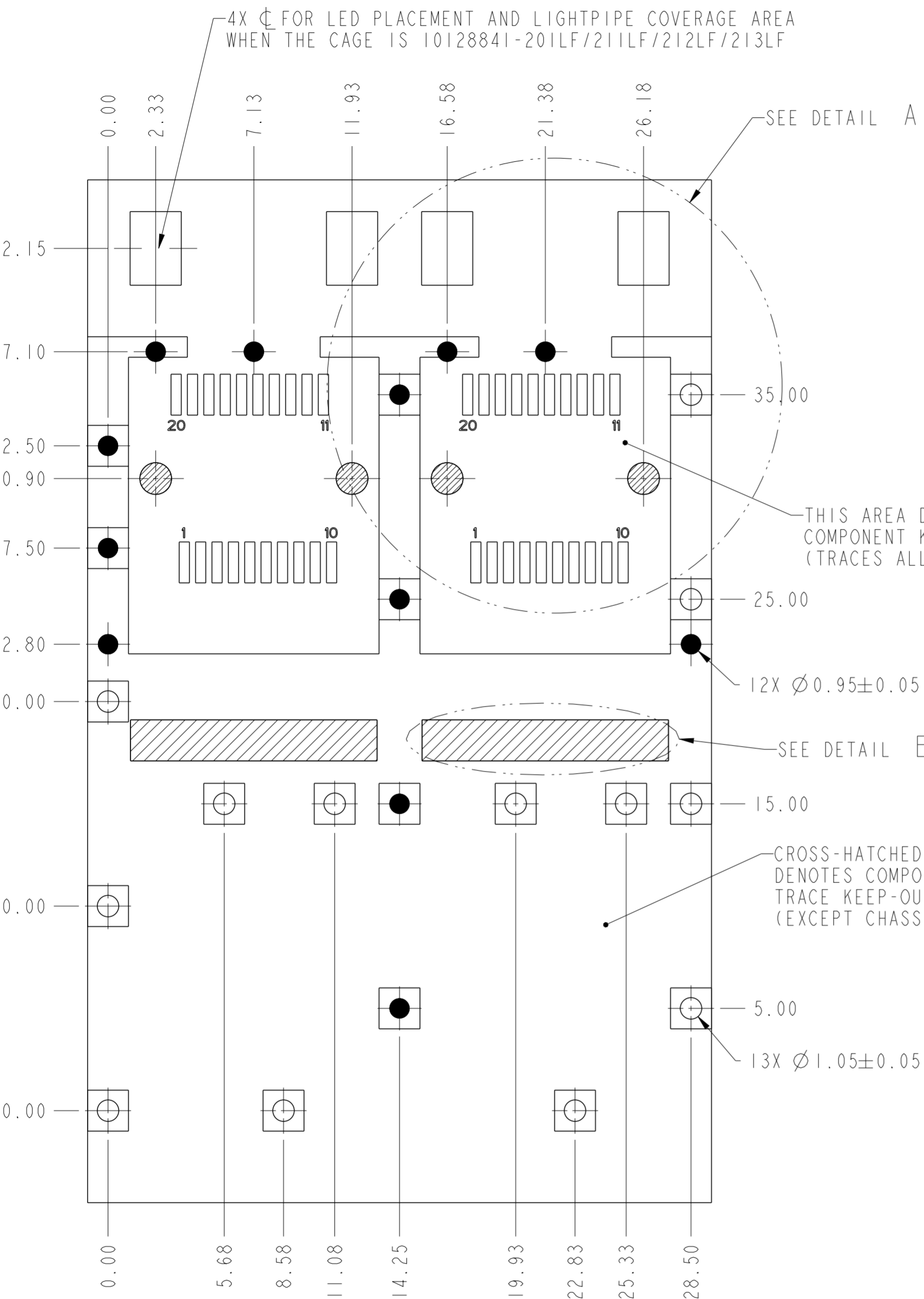

PCB CONFIGURATION WITH KEEP-OUT AREAS
(P/N: 10128841-001LF/002LF/101LF/102LF/201LF)

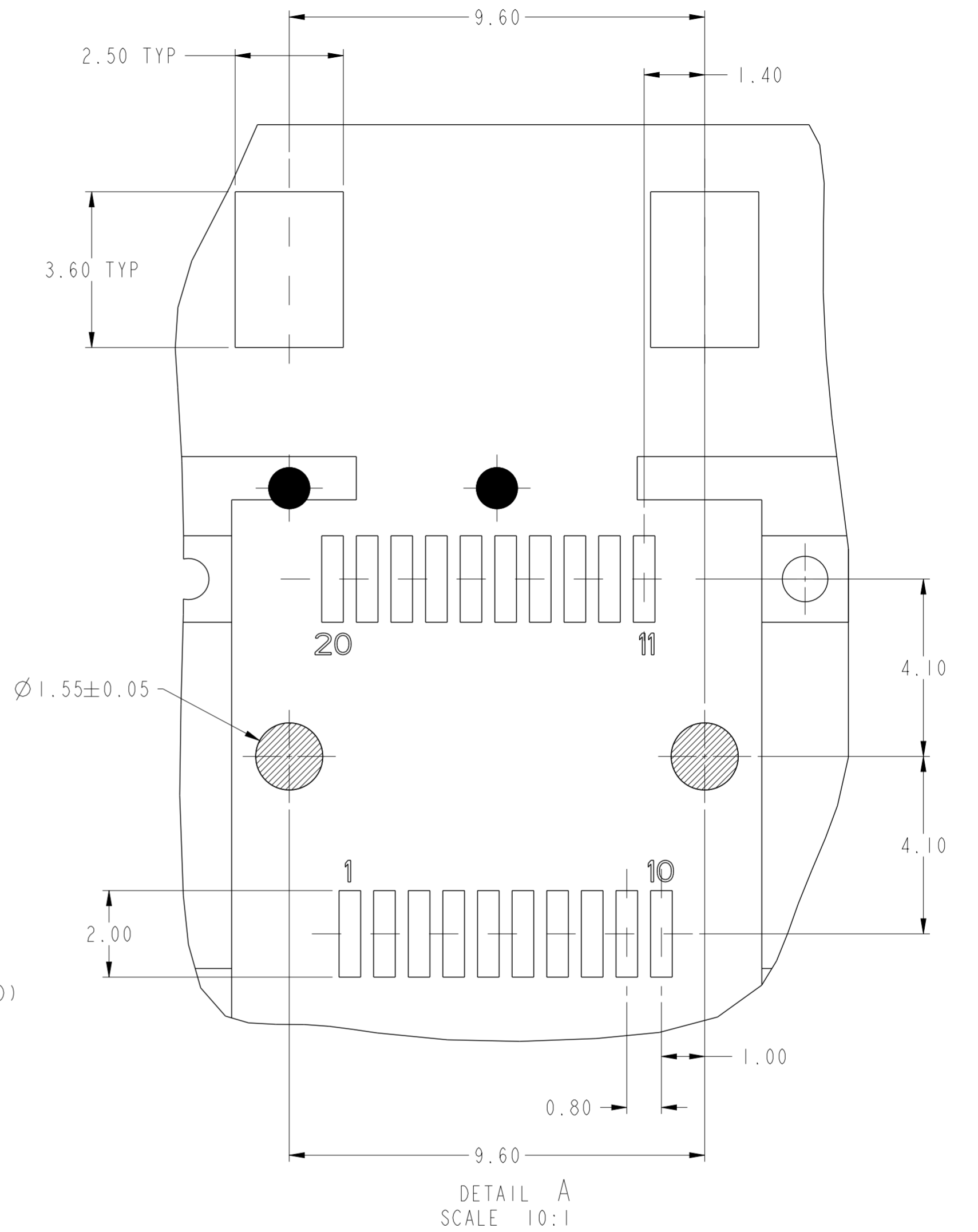

DETAIL A
SCALE 10:1

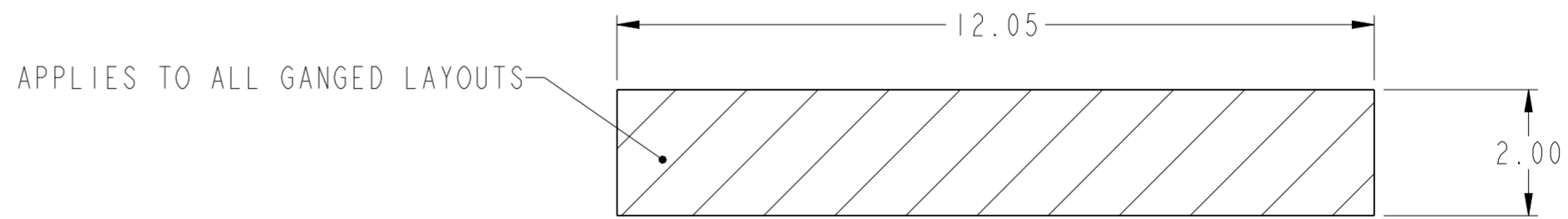

DETAIL B
SCALE 10:1

spec ref	dr	Art Lin	2014/04/21	projection	mm	size	A2	scale	5:1
tolerance std	eng	Art Lin	2015/02/09		mm	ecn no	-	rel level	Released
ISO 406 ISO 1101	chr	-	appr						
surface	linear	0.X	±0.25			SFP+ 1X2 CAGE ASSEMBLY		dwg no 10128841	rev A
ISO 1302	angular	0°	±1°	www.fci.com		cat. no. -		Product - Customer Draw	sheet 10 of 11



Copyright FCI.

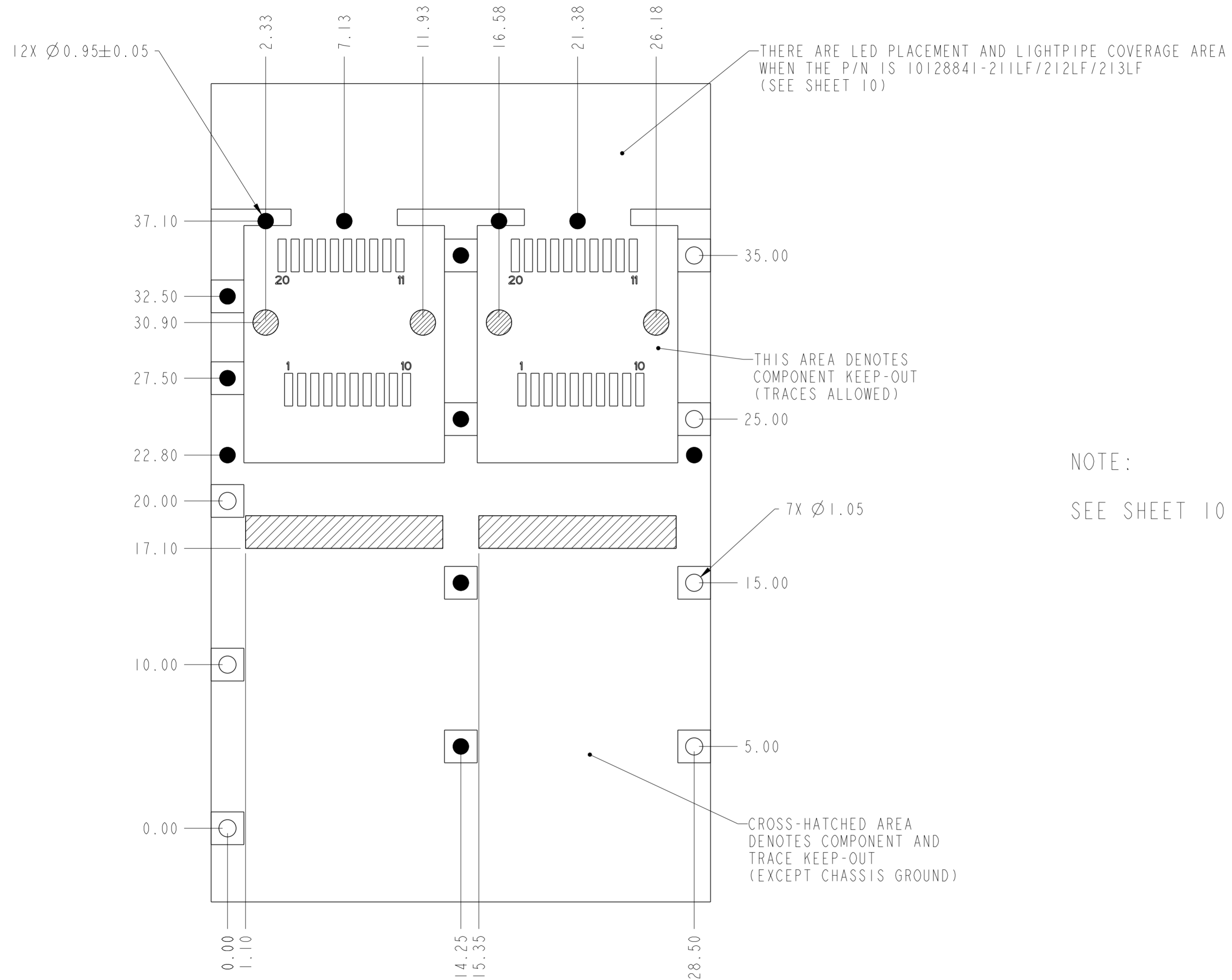

PCB CONFIGURATION WITH KEEP-OUT AREAS
(P/N: 10128841-103LF/211LF/212LF/213LF)

NOTE:
SEE SHEET 10 FOR HOST CONNECTOR LAYOUT

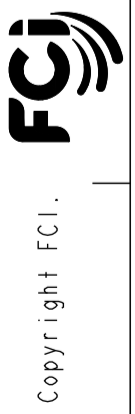

spec ref	dr	Art Lin	2014/04/21	projection	mm	size	A2	scale	1:1	
tolerance std	eng	Art Lin	2015/02/09		mm	ecn no	-	rel level	Released	
ISO 406 ISO 1101	chr	-	appr							Collins Lu
surface	linear	0.X	±0.25		title SFP+ 1X2 CAGE ASSEMBLY LOW PROFILE, SPRING FINGER	dwg no 10128841	rev A	Product - Customer Drw		
ISO 1302	angular	0°	±1°					cat. no.	-	sheet 11 of 11
		www.fci.com								