



MICROCHIP

TC77 Thermal Sensor PICtail™ Demo Board User's Guide

Note the following details of the code protection feature on Microchip devices:

- Microchip products meet the specification contained in their particular Microchip Data Sheet.
- Microchip believes that its family of products is one of the most secure families of its kind on the market today, when used in the intended manner and under normal conditions.
- There are dishonest and possibly illegal methods used to breach the code protection feature. All of these methods, to our knowledge, require using the Microchip products in a manner outside the operating specifications contained in Microchip's Data Sheets. Most likely, the person doing so is engaged in theft of intellectual property.
- Microchip is willing to work with the customer who is concerned about the integrity of their code.
- Neither Microchip nor any other semiconductor manufacturer can guarantee the security of their code. Code protection does not mean that we are guaranteeing the product as "unbreakable."

Code protection is constantly evolving. We at Microchip are committed to continuously improving the code protection features of our products. Attempts to break Microchip's code protection feature may be a violation of the Digital Millennium Copyright Act. If such acts allow unauthorized access to your software or other copyrighted work, you may have a right to sue for relief under that Act.

Information contained in this publication regarding device applications and the like is provided only for your convenience and may be superseded by updates. It is your responsibility to ensure that your application meets with your specifications. MICROCHIP MAKES NO REPRESENTATIONS OR WARRANTIES OF ANY KIND WHETHER EXPRESS OR IMPLIED, WRITTEN OR ORAL, STATUTORY OR OTHERWISE, RELATED TO THE INFORMATION, INCLUDING BUT NOT LIMITED TO ITS CONDITION, QUALITY, PERFORMANCE, MERCHANTABILITY OR FITNESS FOR PURPOSE. Microchip disclaims all liability arising from this information and its use. Use of Microchip devices in life support and/or safety applications is entirely at the buyer's risk, and the buyer agrees to defend, indemnify and hold harmless Microchip from any and all damages, claims, suits, or expenses resulting from such use. No licenses are conveyed, implicitly or otherwise, under any Microchip intellectual property rights.

Trademarks

The Microchip name and logo, the Microchip logo, Accuron, dsPIC, KEELOQ, microID, MPLAB, PIC, PICmicro, PICSTART, PRO MATE, PowerSmart, rfPIC and SmartShunt are registered trademarks of Microchip Technology Incorporated in the U.S.A. and other countries.

AmpLab, FilterLab, Migratable Memory, MXDEV, MXLAB, SEEVAL, SmartSensor and The Embedded Control Solutions Company are registered trademarks of Microchip Technology Incorporated in the U.S.A.

Analog-for-the-Digital Age, Application Maestro, dsPICDEM, dsPICDEM.net, dsPICworks, ECAN, ECONOMONITOR, FanSense, FlexROM, fuzzyLAB, In-Circuit Serial Programming, ICSP, ICEPIC, Linear Active Thermistor, Mindi, MiWi, MPASM, MPLIB, MPLINK, PICKit, PICDEM, PICDEM.net, PICLAB, PICTail, PowerCal, PowerInfo, PowerMate, PowerTool, REAL ICE, rLAB, rfPICDEM, Select Mode, Smart Serial, SmartTel, Total Endurance, UNI/O, WiperLock and ZENA are trademarks of Microchip Technology Incorporated in the U.S.A. and other countries.

SQTP is a service mark of Microchip Technology Incorporated in the U.S.A.

All other trademarks mentioned herein are property of their respective companies.

© 2006, Microchip Technology Incorporated, Printed in the U.S.A., All Rights Reserved.

 Printed on recycled paper.

QUALITY MANAGEMENT SYSTEM
CERTIFIED BY DNV
== ISO/TS 16949:2002 ==

Microchip received ISO/TS-16949:2002 certification for its worldwide headquarters, design and wafer fabrication facilities in Chandler and Tempe, Arizona, Gresham, Oregon and Mountain View, California. The Company's quality system processes and procedures are for its PICmicro® 8-bit MCUs, KEELOQ® code hopping devices, Serial EEPROMs, microperipherals, nonvolatile memory and analog products. In addition, Microchip's quality system for the design and manufacture of development systems is ISO 9001:2000 certified.



TC77 THERMAL SENSOR PICtail™ DEMO BOARD USER'S GUIDE

Table of Contents

Preface	1
Introduction.....	1
Document Layout	1
Conventions Used in this Guide	2
Recommended Reading.....	2
The Microchip Web Site	3
Customer Support	3
Document Revision History	3
Chapter 1. Product Overview	5
1.1 Introduction	5
1.2 What is the TC77 Thermal Sensor PICtail™ Demo Board?	5
1.3 What the TC77 Thermal Sensor PICtail™ Demo Board kit includes	5
Chapter 2. Installation and Operation	7
2.1 Introduction	7
2.2 Features	7
2.3 Getting Started	7
Appendix A. Schematic and Layouts	13
A.1 Introduction	13
A.2 Board Schematic	14
A.3 Board - Top Layer	14
A.4 Board - Silk Screen Layer	15
A.5 Board - Bottom Layer	15
Appendix B. Bill Of Materials (BOM)	17
Worldwide Sales and Service	18

TC77 Thermal Sensor PICtail™ Demo Board User's Guide

NOTES:



TC77 THERMAL SENSOR PICtail™ DEMO BOARD USER'S GUIDE

Preface

NOTICE TO CUSTOMERS

All documentation becomes dated, and this manual is no exception. Microchip tools and documentation are constantly evolving to meet customer needs, so some actual dialogs and/or tool descriptions may differ from those in this document. Please refer to our web site (www.microchip.com) to obtain the latest documentation available.

Documents are identified with a “DS” number. This number is located on the bottom of each page, in front of the page number. The numbering convention for the DS number is “DSXXXXA”, where “XXXX” is the document number and “A” is the revision level of the document.

INTRODUCTION

This chapter contains general information that will be useful to know before using the TC77 Thermal Sensor PICtail™ Demo Board. Items discussed in this chapter include:

- Document Layout
- Conventions Used in this Guide
- Recommended Reading
- The Microchip Web Site
- Customer Support
- Document Revision History

DOCUMENT LAYOUT

This document describes how to use the TC77 Thermal Sensor PICtail™ Demo Board as a development tool. The manual layout is as follows:

- **Chapter 1. “Product Overview”** – Important information about the TC77 Thermal Sensor PICtail™ Demo Board.
- **Chapter 2. “Installation and Operation”** – Includes instructions on how to get started with the TC77 Thermal Sensor PICtail™ Demo Board.
- **Appendix A. “Schematic and Layouts”** – Shows the schematic and board layout diagrams for the TC77 Thermal Sensor PICtail™ Demo Board.
- **Appendix B. “Bill Of Materials (BOM)”** – Lists the parts used to build the TC77 Thermal Sensor PICtail™ Demo Board

TC77 Thermal Sensor PICtail™ Demo Board User's Guide

CONVENTIONS USED IN THIS GUIDE

This manual uses the following documentation conventions:

DOCUMENTATION CONVENTIONS

Description	Represents	Examples
Arial font:		
Italic characters	Referenced books	<i>MPLAB® IDE User's Guide</i>
	Emphasized text	...is the <i>only</i> compiler...
Initial caps	A window	the Output window
	A dialog	the Settings dialog
	A menu selection	select Enable Programmer
Quotes	A field name in a window or dialog	"Save project before build"
Underlined, italic text with right angle bracket	A menu path	<u><i>File>Save</i></u>
Bold characters	A dialog button	Click OK
	A tab	Click the Power tab
N'Rnnnn	A number in verilog format, where N is the total number of digits, R is the radix and n is a digit.	4'b0010, 2'hF1
Text in angle brackets < >	A key on the keyboard	Press <Enter>, <F1>
Courier New font:		
Plain Courier New	Sample source code	#define START
	Filenames	autoexec.bat
	File paths	c:\mcc18\h
	Keywords	_asm, _endasm, static
	Command-line options	-Opa+, -Opa-
	Bit values	0, 1
	Constants	0xFF, 'A'
Italic Courier New	A variable argument	<i>file.o</i> , where <i>file</i> can be any valid filename
Square brackets []	Optional arguments	mcc18 [options] <i>file</i> [options]
Curly brackets and pipe character: { }	Choice of mutually exclusive arguments; an OR selection	errorlevel {0 1}
Ellipses...	Replaces repeated text	var_name [, var_name...]
	Represents code supplied by user	void main (void) { ... }

RECOMMENDED READING

The following Microchip documents are recommended as supplemental reference resources.

TC77 Data Sheet "Thermal Sensor with SPI Interface" (DS20092)

This data sheet provides detailed information regarding the TC77 device.

THE MICROCHIP WEB SITE

Microchip provides online support via our web site at www.microchip.com. This web site is used as a means to make files and information easily available to customers. Accessible by using your favorite internet browser, the web site contains the following information:

- **Product Support** – Data sheets and errata, application notes and sample programs, design resources, user's guides and hardware support documents, latest software releases and archived software
- **General Technical Support** – Frequently Asked Questions (FAQs), technical support requests, online discussion groups, Microchip consultant program member listing
- **Business of Microchip** – Product selector and ordering guides, latest Microchip press releases, listing of seminars and events, listings of Microchip sales offices, distributors and factory representatives

CUSTOMER SUPPORT

Users of Microchip products can receive assistance through several channels:

- Distributor or Representative
- Local Sales Office
- Field Application Engineer (FAE)
- Technical Support
- Development Systems Information Line

Customers should contact their distributor, representative or field application engineer for support. Local sales offices are also available to help customers. A listing of sales offices and locations is included in the back of this document.

Technical support is available through the web site at: <http://support.microchip.com>.

DOCUMENT REVISION HISTORY

Revision B (May 2006)

- Updated Bill of Materials (BOM) to show RoHS-compliant part numbers.

Revision A (June 2004)

- Initial Release of this Document.

TC77 Thermal Sensor PICtail™ Demo Board User's Guide

NOTES:



TC77 THERMAL SENSOR PICtail™ DEMO BOARD USER'S GUIDE

Chapter 1. Product Overview

1.1 INTRODUCTION

This chapter provides an overview of the TC77 Thermal Sensor PICtail™ Demo Board and covers the following topics:

- What is the TC77 Thermal Sensor PICtail™ Demo Board?
- What the TC77 Thermal Sensor PICtail™ Demo Board Kit includes

1.2 WHAT IS THE TC77 THERMAL SENSOR PICtail™ DEMO BOARD?

The TC77 Thermal Sensor PICtail™ Demo Board demonstrates how to interface the TC77 to a PICmicro® microcontroller using the PICkit™ 1 Flash Starter Kit as a platform. A PIC16F676 14-pin Flash-based 8-bit CMOS microcontroller device is included with the demo board and can be used with the PICkit 1 Flash Starter Kit. Firmware that provides the SPI interface and temperature conversion routines to communicate with the TC77 and convert the serial data to temperature is also included.

The TC77 Thermal Sensor PICtail™ Demo Board can also be used as a “stand-alone” module to quickly add thermal sensing capability to any existing application. This basic sensor functionality is implemented on a small Printed Circuit Board (PCB) and an interface via a standard 100 mil header.

1.3 WHAT THE TC77 THERMAL SENSOR PICtail™ DEMO BOARD KIT INCLUDES

This TC77 Thermal Sensor PICtail™ Demo Board Kit includes:

- The TC77 Thermal Sensor PICtail™ Demo Board (102-00004)
- TC77 Thermal Sensor PICtail™ Demo Board User's Guide (DS51484)
- AN913, “Interfacing the TC77 Thermal Sensor to a PICmicro® Microcontroller”, (DS00913).
- PIC16F676 14-pin Flash-based 8-bit CMOS Microcontroller
- PIC16F676 Firmware

TC77 Thermal Sensor PICtail™ Demo Board User's Guide

NOTES:

Chapter 2. Installation and Operation

2.1 INTRODUCTION

The TC77 Thermal Sensor PICtail™ Demo Board demonstrates how to interface the TC77 to a microcontroller for use by the system designer as an example of how to integrate a digital temperature sensor into their system.

2.2 FEATURES

The TC77 Thermal Sensor PICtail™ Demo Board has the following features:

- Small PCB layout
- Standard 100 mil 14-pin header (P1) for easy interface to the PICkit™ 1 Flash Starter Kit or custom application

2.3 GETTING STARTED

This section describes how to quickly configure the TC77 Thermal Sensor PICtail™ Demo Board and PICkit 1 Flash Starter Kit. A block diagram of the configuration is provided in Figure 2-1. Refer to Application Note 913, “*Interfacing the TC77 Thermal Sensor to a PICmicro® Microcontroller*” (DS00913), for detailed information on the TC77 Thermal Sensor PICtail Board and the TC77 PICtail.HEX firmware.

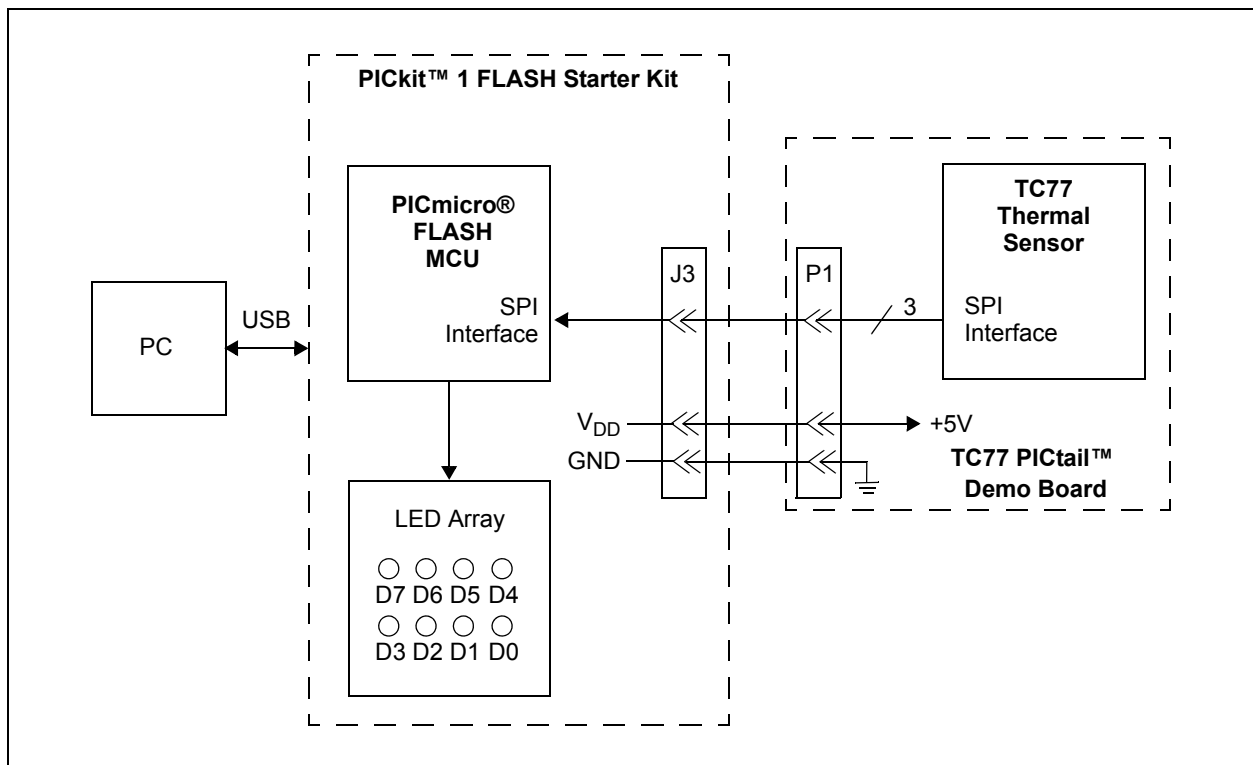

FIGURE 2-1: TC77 Thermal Sensor PICtail™ Demo Board Block Diagram.

TC77 Thermal Sensor PICtail™ Demo Board User's Guide

2.3.1 Hardware Setup

1. Connect the P1 header of the TC77 Thermal Sensor board to the J3 connector on the PICkit 1 Flash Starter Kit board. Refer to Figure 2-2 for proper orientation of the TC77 Thermal Sensor PICtail™ Demo Board and Figure 2-3 for a simplified board schematic.
2. Insert the PIC16F676 into the evaluation socket of the PICkit 1 Flash Starter Kit board.
3. Connect the PICkit 1 Flash Starter Kit USB cable from the USB port of the PC to the USB port (J1) on the PICkit 1 Flash Starter Kit board. +5V power is supplied to the PICkit 1 Flash Starter Kit board via the USB cable. The green **POWER** LED and the red **BUSY** LED will turn on, indicating that power is being supplied to the board.

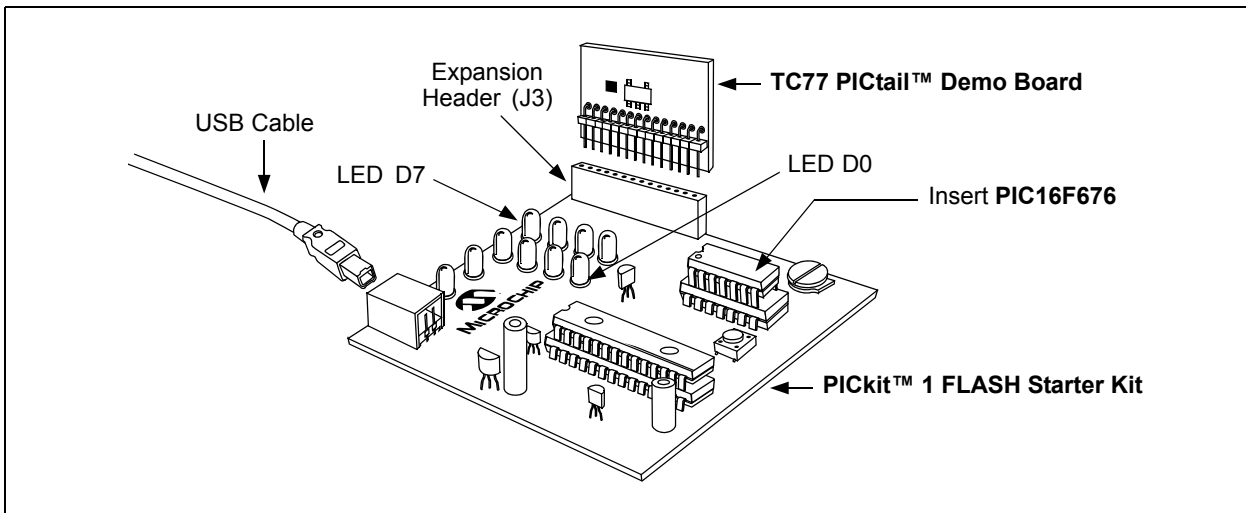

FIGURE 2-2: TC77 Thermal Sensor PICtail™ Demo Board and PICkit™ 1 FLASH Starter Kit.

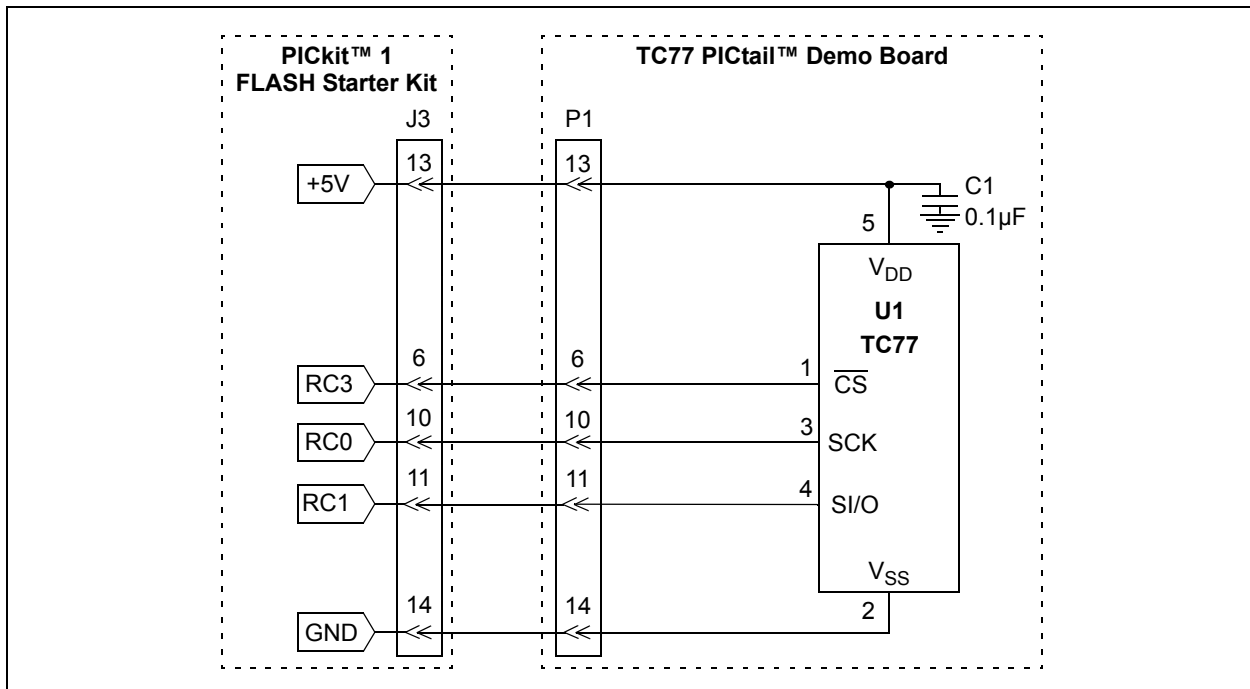

FIGURE 2-3: Simplified TC77 Thermal Sensor PICtail™ Demo Board Schematic.

2.3.2 Programming the PIC16F676

1. Download and install the PICkit 1 Flash Starter Kit software to your PC.
2. Copy the TC77 PICtail.HEX file supplied on the CD that came with this kit to your PC.
3. When the PICkit 1 Flash Starter Kit is started, the main window will be displayed on the PC as indicated in Figure 2-4.

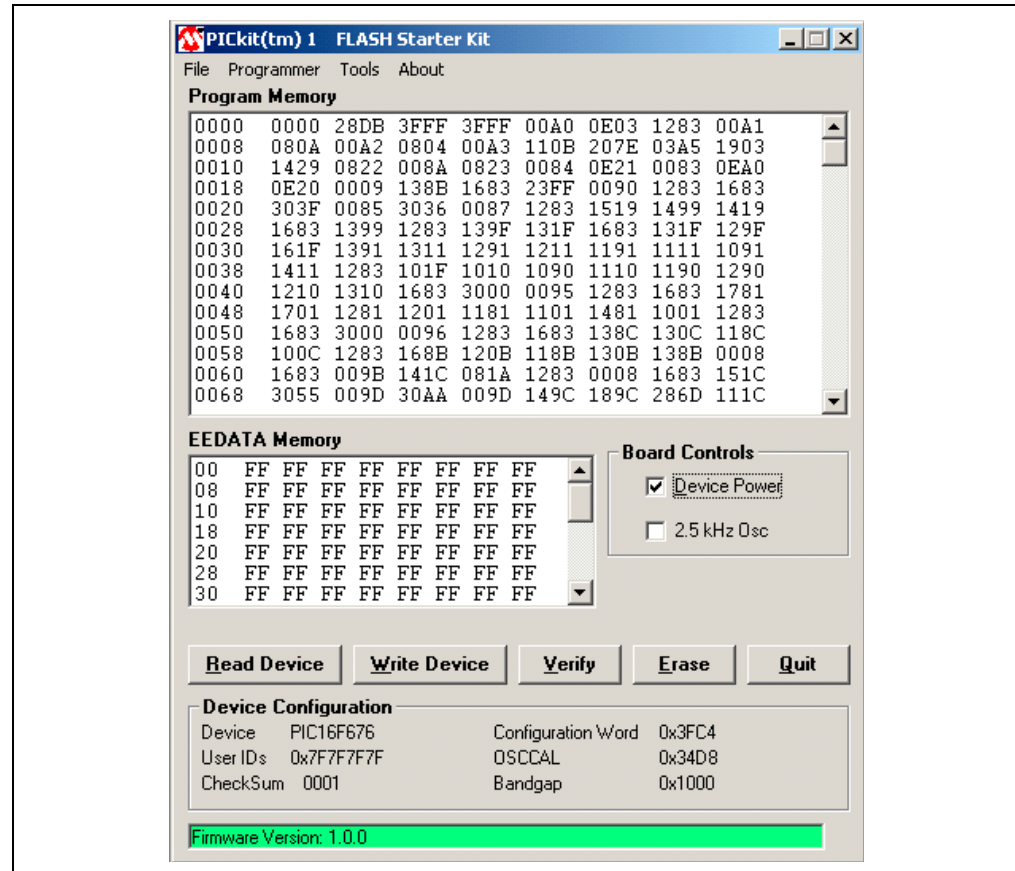

FIGURE 2-4: PICkit™ 1 Flash Starter Kit GUI Window on the PC.

4. Toggle device power to off by unchecking the **Device Power** box under **Board Controls** in the PICkit 1 Flash Starter Kit window (Figure 2-4). The **BUSY** LED on the PICkit 1 Flash Starter Kit board will turn off when the device power is turned off.
5. Click on the **Erase** button in the window to ensure that the PIC16F676 device has been erased.
6. From the **File** pull down menu, select **Import HEX**. A file window will appear. Select and open **TC77 PICtail.HEX**.
7. Click on the **Write Device** button in the PICkit 1 Flash Starter Kit window. The PIC16F676 device will be written to with the TC77 PICtail.HEX firmware. Once completed, the status bar at the bottom of the window will indicate **Write Successful**.
8. Toggle the device power on by checking the **Device Power** box under **Board Controls** in the PICkit 1 Flash Starter Kit window. The **BUSY** LED on the PICkit 1 Flash Starter Kit board will turn on when device power is turned on. Some of the red LEDs (D7-D0) will turn on as well.

TC77 Thermal Sensor PICtail™ Demo Board User's Guide

At this point, the PIC16F676 is reading the temperature data from the TC77 and displaying that temperature on the eight red LEDs (D7-D0) on the PICKit 1 Flash Starter Kit board. The ten's digit of the temperature data is represented by bits, D7-D4, with D7 being defined as the Most Significant bit (MSb). The one's digit is defined by bits, D3-D0, with D3 serving as the MSb.

The temperature can be displayed in degrees Fahrenheit or Celsius. The board defaults to the temperature being displayed in Fahrenheit. To display the temperature in Celsius, depress the **SW1** push button switch on the PICKit 1 Flash Starter Kit board. The display will change back to Fahrenheit when **SW1** is released.

Table 2-1 provides a list of the LED patterns that correspond to the Binary Code Decimal (BCD) coding representation of the temperature measurement.

TABLE 2-1: BCD CODE REPRESENTATION ON PICKit™ 1 FLASH STARTER KIT LEDs

Binary	BCD Number	D7 D3	D6 D2	D5 D1	D4 D0
0000	0	OFF	OFF	OFF	OFF
0001	1	OFF	OFF	OFF	ON
0010	2	OFF	OFF	ON	OFF
0011	3	OFF	OFF	ON	ON
0100	4	OFF	ON	OFF	OFF
0101	5	OFF	ON	OFF	ON
0110	6	OFF	ON	ON	OFF
0111	7	OFF	ON	ON	ON
1000	8	ON	OFF	OFF	OFF
1001	9	ON	OFF	OFF	ON

For example, a temperature reading of 75°F will be displayed by turning on LEDs D6, D5, D4, D2 and D0 (LEDs D7, D3 and D1 will be turned off), as indicated in Figure 2-5.

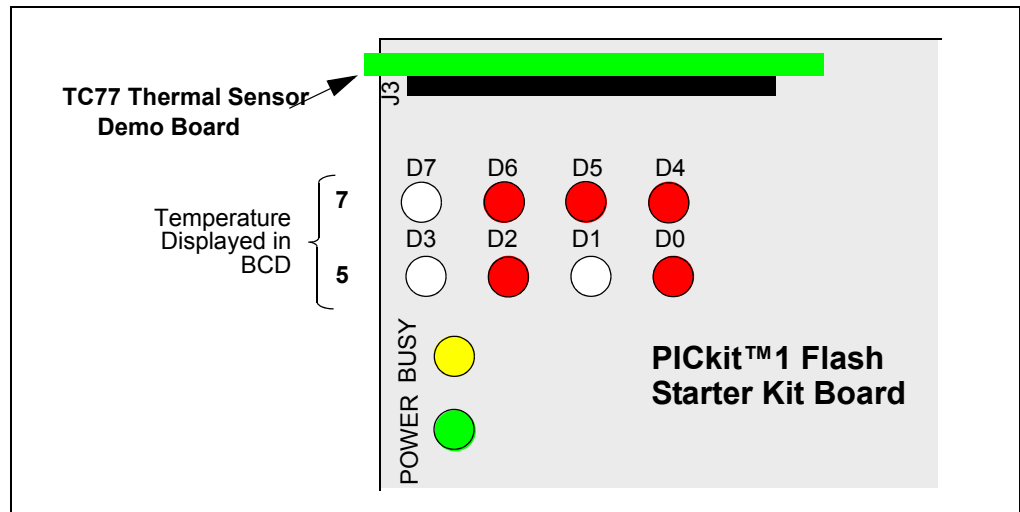

FIGURE 2-5: PICkit™ 1 Flash Starter Kit LED Display of 75°F.

The temperature display will change when the temperature of the TC77 is varied. A simple example of this can be seen by pressing your finger on the TC77 device (U1) on the TC77 Thermal Sensor PICtail™ Demo Board. More dramatic changes can be seen by applying heat to the TC77 with a hair dryer or hot air gun, or cooling the device down.

Refer to the TC77 Data Sheet, “*Thermal Sensor with SPI™ Interface*” (DS20092) for more information on the TC77 and Application Note 913, “*Interfacing the TC77 Thermal Sensor to a PICmicro® Microcontroller*” (DS00913) for more information on the TC77 Thermal Sensor PICtail™ Demo Board and the TC77 PICtail.HEX firmware.

TC77 Thermal Sensor PICtail™ Demo Board User's Guide

NOTES:



TC77 THERMAL SENSOR PICtail™ DEMO BOARD USER'S GUIDE

Appendix A. Schematic and Layouts

A.1 INTRODUCTION

This appendix contains the following schematics and layouts for the TC77 Thermal Sensor PICtail™ Demo Board:

- Board Schematic
- Board - Top Layer
- Board - Silk screen Layer
- Board - Bottom Layer

TC77 Thermal Sensor PICtail™ Demo Board User's Guide

A.2 BOARD SCHEMATIC

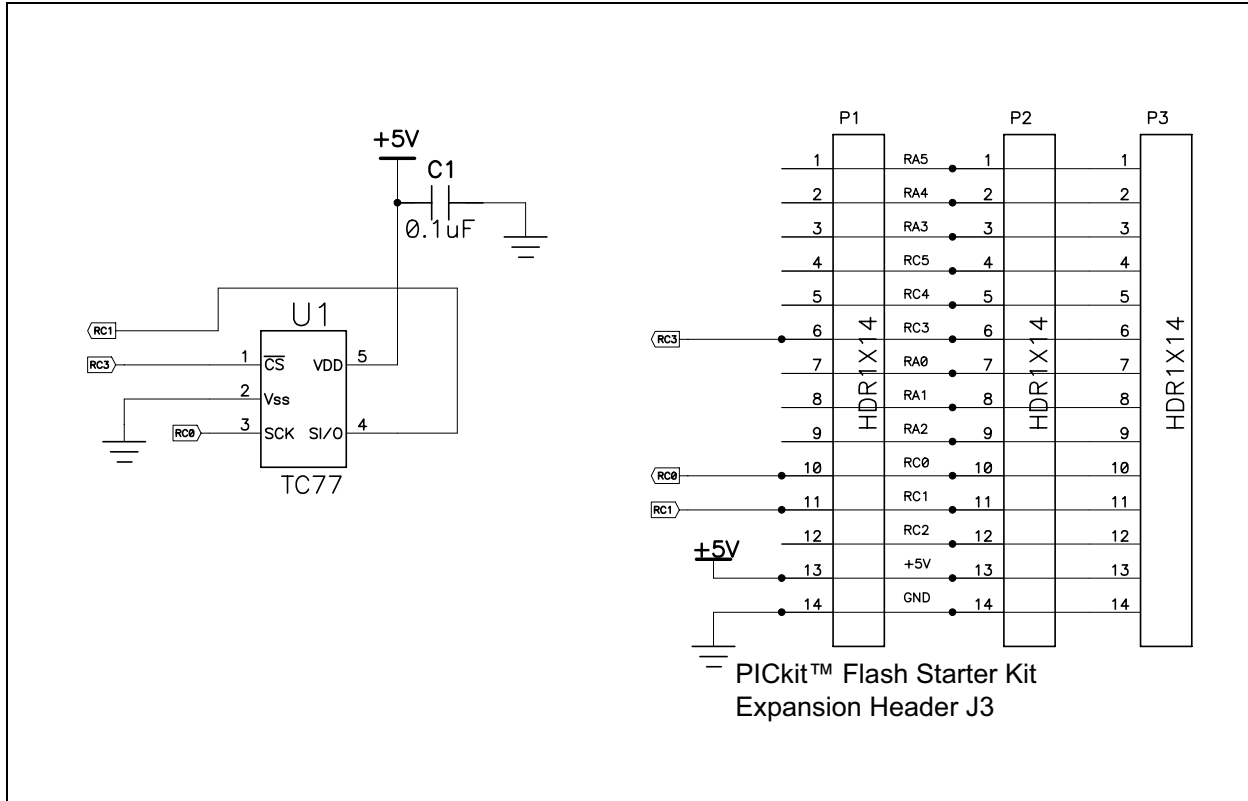

A.3 BOARD - TOP LAYER

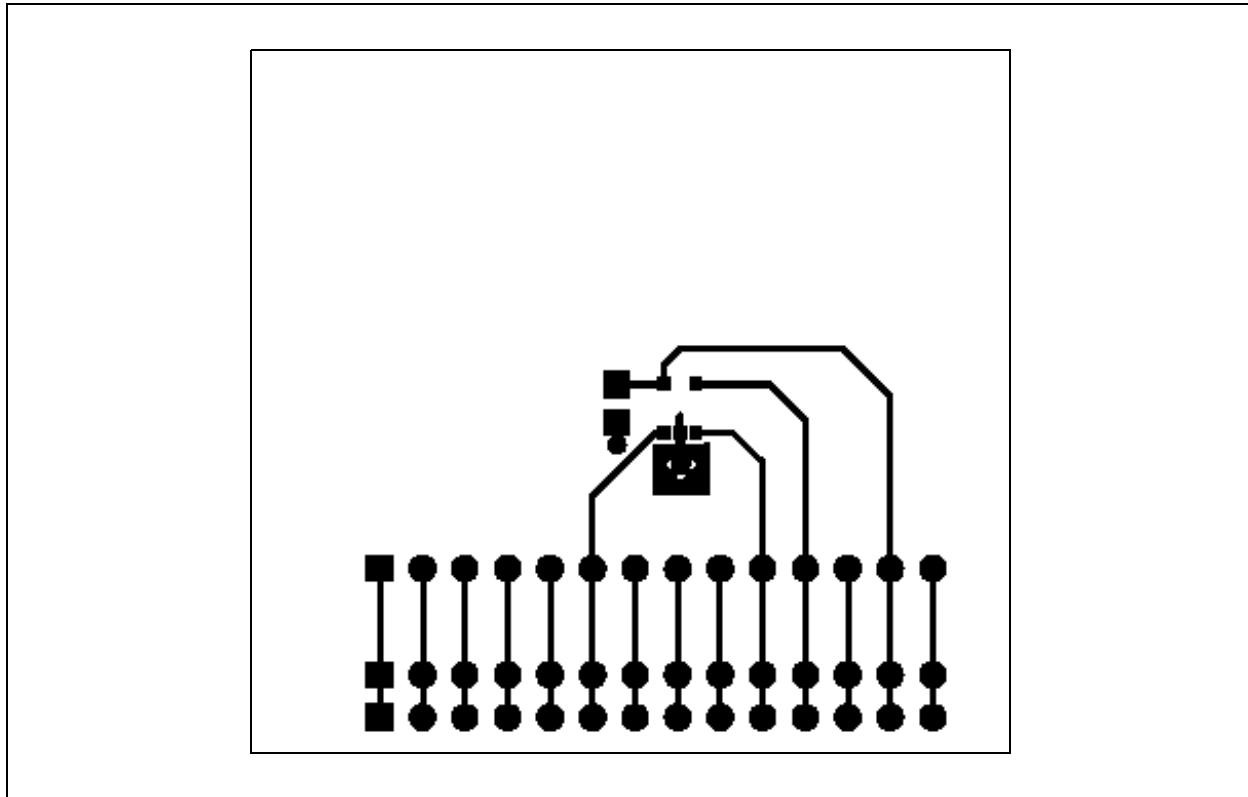

A.4 BOARD - SILK SCREEN LAYER

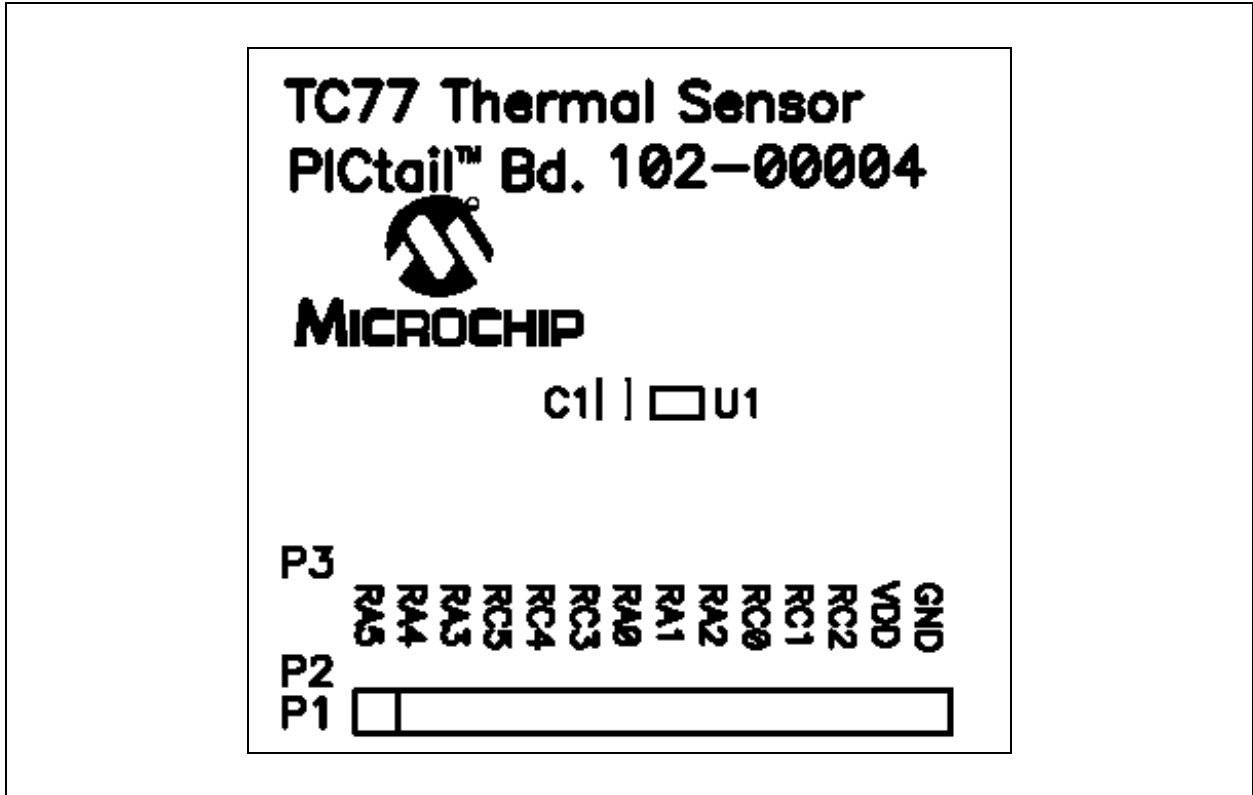

A.5 BOARD - BOTTOM LAYER

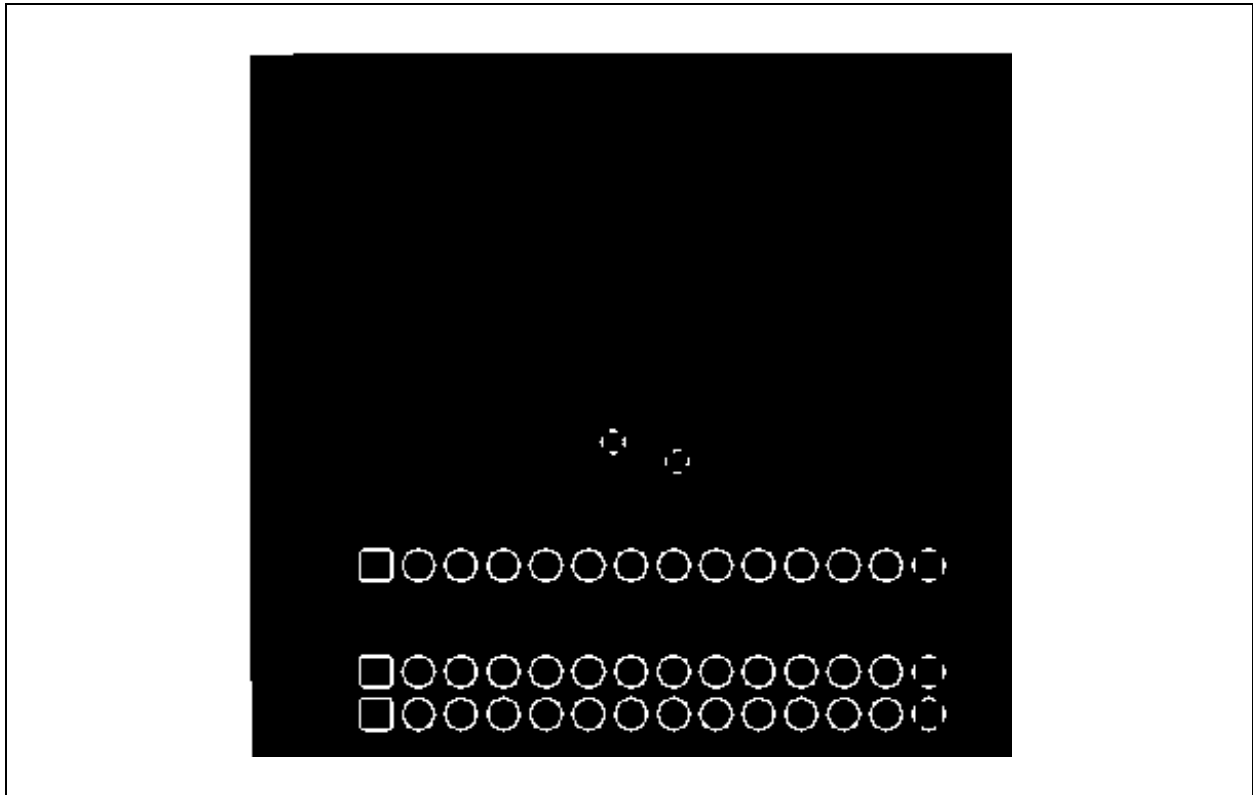

TC77 Thermal Sensor PICtail™ Demo Board User's Guide

NOTES:



TC77 THERMAL SENSOR PICtail™ DEMO BOARD USER'S GUIDE

Appendix B. Bill Of Materials (BOM)

TABLE B-1: BILL OF MATERIALS (BOM)

Qty	Designator	Description	Manufacturer	Part Number
1	C1	CAP .1UF 25V CERAMIC X7R 0805	Panasonic® - ECG	ECJ-2VB1E104K
1	P1	CONN HEADER .100 SINGL R/A 14POS	Sullins Electronics Corp.	PEC14SBAN
2	P2,P3,	"Do Not Populate" Header, single pin	N/A	N/A
1	PCB	Lead Free RoHS Compliant PCBs	N/A	104-00005
1	U1	TC77 Thermal Sensor with SPI Interface	Microchip Technology Inc	TC77-5.0MCTTR



MICROCHIP

WORLDWIDE SALES AND SERVICE

AMERICAS

Corporate Office
2355 West Chandler Blvd.
Chandler, AZ 85224-6199
Tel: 480-792-7200
Fax: 480-792-7277
Technical Support:
<http://support.microchip.com>
Web Address:
www.microchip.com

Atlanta

Alpharetta, GA
Tel: 770-640-0034
Fax: 770-640-0307

Boston

Westborough, MA
Tel: 774-760-0087
Fax: 774-760-0088

Chicago

Itasca, IL
Tel: 630-285-0071
Fax: 630-285-0075

Dallas

Addison, TX
Tel: 972-818-7423
Fax: 972-818-2924

Detroit

Farmington Hills, MI
Tel: 248-538-2250
Fax: 248-538-2260

Kokomo

Kokomo, IN
Tel: 765-864-8360
Fax: 765-864-8387

Los Angeles

Mission Viejo, CA
Tel: 949-462-9523
Fax: 949-462-9608

San Jose

Mountain View, CA
Tel: 650-215-1444
Fax: 650-961-0286

Toronto

Mississauga, Ontario,
Canada
Tel: 905-673-0699
Fax: 905-673-6509

ASIA/PACIFIC

Australia - Sydney
Tel: 61-2-9868-6733
Fax: 61-2-9868-6755

China - Beijing
Tel: 86-10-8528-2100
Fax: 86-10-8528-2104

China - Chengdu
Tel: 86-28-8676-6200
Fax: 86-28-8676-6599

China - Fuzhou
Tel: 86-591-8750-3506
Fax: 86-591-8750-3521

China - Hong Kong SAR
Tel: 852-2401-1200
Fax: 852-2401-3431

China - Qingdao
Tel: 86-532-8502-7355
Fax: 86-532-8502-7205

China - Shanghai
Tel: 86-21-5407-5533
Fax: 86-21-5407-5066

China - Shenyang
Tel: 86-24-2334-2829
Fax: 86-24-2334-2393

China - Shenzhen
Tel: 86-755-8203-2660
Fax: 86-755-8203-1760

China - Shunde
Tel: 86-757-2839-5507
Fax: 86-757-2839-5571

China - Wuhan
Tel: 86-27-5980-5300
Fax: 86-27-5980-5118

China - Xian
Tel: 86-29-8833-7250
Fax: 86-29-8833-7256

ASIA/PACIFIC

India - Bangalore
Tel: 91-80-4182-8400
Fax: 91-80-4182-8422

India - New Delhi
Tel: 91-11-5160-8631
Fax: 91-11-5160-8632

India - Pune
Tel: 91-20-2566-1512
Fax: 91-20-2566-1513

Japan - Yokohama
Tel: 81-45-471- 6166
Fax: 81-45-471-6122

Korea - Gumi
Tel: 82-54-473-4301
Fax: 82-54-473-4302

Korea - Seoul
Tel: 82-2-554-7200
Fax: 82-2-558-5932 or
82-2-558-5934

Malaysia - Penang
Tel: 60-4-646-8870
Fax: 60-4-646-5086

Philippines - Manila
Tel: 63-2-634-9065
Fax: 63-2-634-9069

Singapore
Tel: 65-6334-8870
Fax: 65-6334-8850

Taiwan - Hsin Chu
Tel: 886-3-572-9526
Fax: 886-3-572-6459

Taiwan - Kaohsiung
Tel: 886-7-536-4818
Fax: 886-7-536-4803

Taiwan - Taipei
Tel: 886-2-2500-6610
Fax: 886-2-2508-0102

Thailand - Bangkok
Tel: 66-2-694-1351
Fax: 66-2-694-1350

EUROPE

Austria - Wels
Tel: 43-7242-2244-399
Fax: 43-7242-2244-393

Denmark - Copenhagen
Tel: 45-4450-2828
Fax: 45-4485-2829

France - Paris
Tel: 33-1-69-53-63-20
Fax: 33-1-69-30-90-79

Germany - Munich
Tel: 49-89-627-144-0
Fax: 49-89-627-144-44

Italy - Milan
Tel: 39-0331-742611
Fax: 39-0331-466781

Netherlands - Drunen
Tel: 31-416-690399
Fax: 31-416-690340

Spain - Madrid
Tel: 34-91-708-08-90
Fax: 34-91-708-08-91

UK - Wokingham
Tel: 44-118-921-5869
Fax: 44-118-921-5820

02/16/06