

**LOW -VOLTAGE ADJUSTABLE PRECISION
 SHUNT REGULATOR**

FEATURES

- SOT-23 Packages
- Voltage Reference Initial Accuracy (1%)
- Low Operating Cathode Current (80µA max)
- Unconditionally Stable with only 1µF
- Adjustable Output from 1.24V to 15V
- 0.25Ω Typical Output Impedance
- Pin to Pin Compatible with TLV431

APPLICATIONS

- Precision Voltage Reference
- Linear Regulator Controller
- Secondary Side Controller for the low voltage power supply applications

DESCRIPTION

The IRU431L is a three-terminal adjustable shunt regulator that can also be used as a precision voltage reference. Its output voltage may be set to any value between $V_{REF}(1.24V)$ and 15V with two external resistors as shown in the typical application circuit. Other applications of this device include being used as a merged amplifier and reference in applications such as a linear regulator or as the secondary side controller in low voltage power supply applications. The IRU431L only requires 80µA maximum quiescent current before regulating, making it ideal as an efficient voltage reference for battery type applications. The IRU431L has $\pm 1\%$ initial accuracy.

TYPICAL APPLICATION

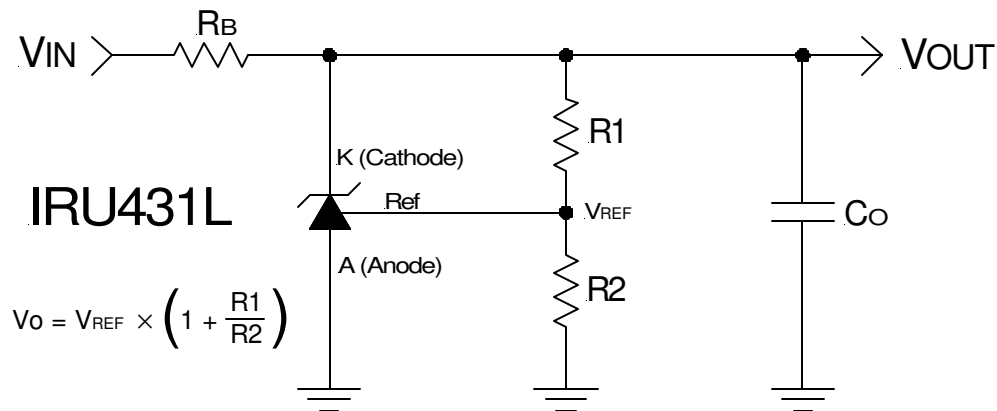

Figure 1 - Typical application of the IRU431L as a shunt regulator / voltage reference.

PACKAGE ORDER INFORMATION

T_A (°C)	3-PIN SOT-23 (L3)	5-PIN SOT-23 (L5)
0 To 70	IRU431LCL3	IRU431LCL5

ABSOLUTE MAXIMUM RATINGS

Input Voltage (V_{IN})	15V
Continuous Cathode Current Range	-15mA to +15mA
Reference Current Range	-0.05mA to 15mA
Storage Temperature Range	-65°C to 150°C
Operating Junction Temperature Range	0°C to 150°C

CAUTION: Stresses above those listed in "Absolute Maximum Ratings" may cause permanent damage to the device.

PACKAGE INFORMATION

3-PIN SOT-23 (L3)	5-PIN SOT-23 (L5)
<p style="text-align: center;">TOP VIEW</p> <p style="text-align: center;">$\theta_{JA}=336^{\circ}\text{C/W}$</p>	<p style="text-align: center;">TOP VIEW</p> <p style="text-align: center;">$\theta_{JA}=256^{\circ}\text{C/W}$</p>

ELECTRICAL SPECIFICATIONS

Unless otherwise specified, these specifications apply over $T_A=0$ to 70°C , $C_o=1\mu\text{F}$. Typical values refer to $T_A=25^{\circ}\text{C}$. Low duty cycle pulse testing is used which keeps junction and case temperatures equal to the ambient temperature.

PARAMETER	SYM	TEST CONDITION	MIN	TYP	MAX	UNITS
Reference Voltage IRU431L	V_{REF}	$I_K=10\text{mA}$, $V_{KA}=V_{REF}$, $T_A=25^{\circ}\text{C}$ $I_K=10\text{mA}$, $V_{KA}=V_{REF}$	1.228 1.221	1.240 1.240	1.252 1.259	V
V_{REF} Deviation over full temperature range	$V_{REF(DEV)}$	$V_{KA}=V_{REF}$, $I_K=10\text{mA}$		6		mV
Ratio of V_{REF} change to cathode voltage change	$\Delta V_{REF}/\Delta V_{KA}$	$I_K=10\text{mA}$, $\Delta V_{KA}=V_{REF}$ to 6V		-1	-6	mV/V
Reference Pin Current		$I_K=10\text{mA}$, $R_1=10\text{K}\Omega$, $R_2=\text{open}$		0.15	1	μA
I_{REF} Deviation over full temperature range	$I_{REF(DEV)}$	$I_K=10\text{mA}$, $R_1=10\text{K}\Omega$, $R_2=\text{open}$		0.05		μA
Minimum Cathode Current	$I_{K(MIN)}$	$V_{KA}=V_{REF}$		55	80	μA
Off State Cathode Current	I_{off}	$V_{KA}=6\text{V}$, $V_{REF}=0\text{V}$ $V_{KA}=10\text{V}$, $V_{REF}=0\text{V}$ $V_{KA}=15\text{V}$, $V_{REF}=0\text{V}$		0.6 1.8 3.2	0.75 5 10	μA
Dynamic Impedance	Z_{KA0}	$V_{KA}=V_{REF}$, $f<1\text{KHz}$, $I_K=0.1$ to 15mA , Note 1		0.25	0.4	Ω

Note 1: The dynamic impedance when $V_{KA}=V_{REF}$ is defined as:

$$|Z_{KA0}| = \frac{\Delta V_{KA}}{\Delta I_K}$$

When the device is operating with two external resistors (See Figure 3), the total dynamic impedance of the circuit is given by:

$$|Z_{KA}| = \frac{\Delta V}{\Delta I} = |Z_{KA0}| \times \left(1 + \frac{R_1}{R_2} \right)$$

The deviation parameters, $V_{REF(DEV)}$ and $I_{REF(DEV)}$ are defined as the differences between the maximum and the minimum values obtained over the rated temperature range. The average full range temperature coefficient of the reference input voltage is defined as:

$$|\alpha V_{REF}| = \frac{\left(\frac{V_{REF(DEV)}}{V_{REF(25^{\circ}C)}} \right) \times 10^6}{\Delta T_A}$$

Where:

$|\alpha V_{REF}|$ unit is ppm/°C

ΔT_A is the rated operating free air temperature of the device.

αV_{REF} can be positive or negative depending on whether minimum V_{REF} or maximum V_{REF} respectively occurs at the lower temperature.

PIN DESCRIPTIONS

5-PIN	3-PIN	PIN SYMBOL	PIN DESCRIPTION
4	1	Ref	Resistors from the Ref pin to the Cathode pin and to ground form a divider that sets the output voltage.
3	2	Cathode	The output of the shunt regulator. A capacitor of 1 μ F minimum value must be connected from this pin to Anode pin to insure unconditional stability.
5	3	Anode	Ground pin. This pin must be connected to the lowest potential in the system and all other pins must be at higher potential with respect to this pin.
1, 2	NA	NC	These pins are not connected internally.

BLOCK DIAGRAM

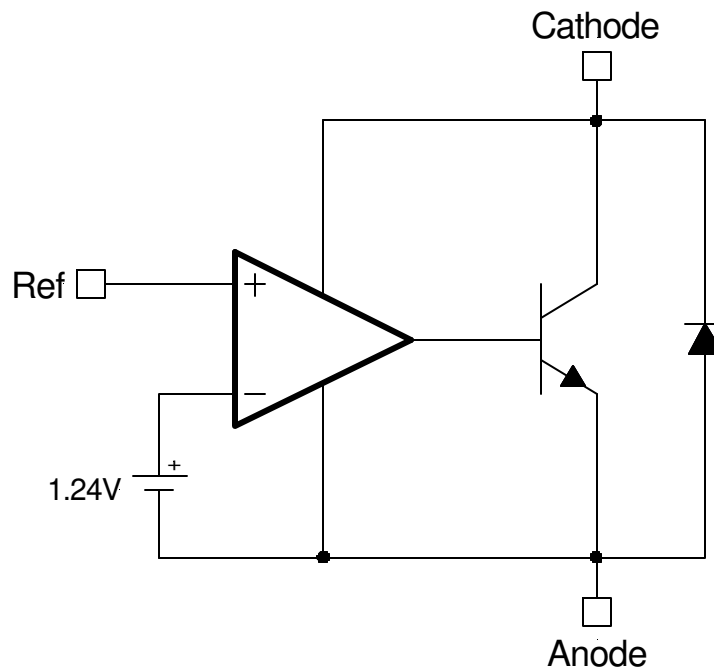

Figure 2 - Simplified block diagram of the IRU431L.

APPLICATION INFORMATION

Output Voltage Setting

The IRU431L can be programmed to any voltages in the range of 1.24 to 15V with the addition of R1 and R2 external resistors according to the following formula:

$$V_O = V_{KA} = V_{REF} \times \left(1 + \frac{R_1}{R_2}\right) + I_{REF} \times R_1$$

The IRU431L keeps a constant voltage of 1.240V between the Ref pin and Ground pin. By placing a resistor R2 across these two pins a constant current flows through R2, adding to the I_{REF} current and into the R1 resistor producing a voltage equal to:

$$\left(\frac{1.240}{R_2}\right) \times R_1 + I_{REF} \times R_1$$

which will be added to the 1.240V to set the output voltage as shown in the above equation. Since the input bias current of the Ref pin is 0.5μA max, it adds a very small error to the output voltage and for most applications can be ignored. For example, in a typical 5V to 3.3V application where R2=1.21KΩ and R1=2KΩ the error due to the I_{ADJ} is only 1mV which is about 0.03% of the nominal set point.

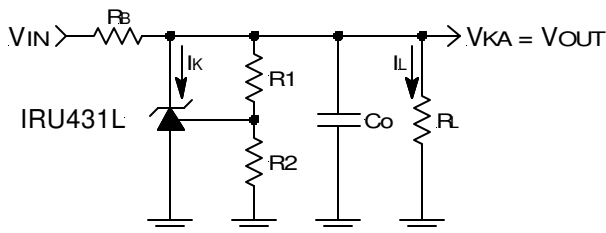

Figure 3 - Typical application of the IRU431L for programming the output voltage.

Biasing Resistor (R_B) Selection

The biasing resistor R_B is selected such that it does not limit the input current under the minimum input supply and maximum load and biasing current.

An example is given below on how to properly select the biasing resistor.

Assuming:

$$\begin{aligned} V_{MIN} &= 4.5V \\ V_{MAX} &= 6V \\ V_{KA} &= 3.3V \\ I_L &= 10mA \end{aligned}$$

The maximum value for the biasing resistor is calculated using the following equations:

$$R_{B(MAX)} = \frac{V_{MIN} - V_{KA}}{I_{B(MAX)} + I_{L(MAX)}}$$

$$I_{B(MAX)} = I_{K(MIN)} + I_R$$

Where:

- V_{MIN} = Minimum supply voltage
- I_{L(MAX)} = Maximum load current
- I_{B(MAX)} = Maximum bias current
- I_{K(MIN)} = Maximum value for the minimum cathode current spec
- I_R = Current through R1

Assuming R1 = 2KΩ as before,

$$I_R = \frac{3.3 - 1.24}{2} = 1.03mA$$

$$I_{B(MAX)} = 0.08 + 1.03 = 1.11mA$$

$$R_{B(MAX)} = \frac{4.5 - 3.3}{1.11 + 10} = 108\Omega$$

Select R_B = 100Ω

The maximum power dissipation of the resistor is calculated under the maximum supply voltage as follows:

$$P_{R_B(MAX)} = \frac{(V_{MAX} - V_{KA})^2}{R_B}$$

Where:

- V_{MAX} = Maximum supply voltage
- P_{R_B(MAX)} = Maximum R_B power dissipation

$$P_{R_B(MAX)} = \frac{(6 - 3.3)^2}{100} = 73mW$$

Thermal Design

The IRU431L is offered in the surface mount SOT-23 (L) packages. The SOT-23 package has the maximum power dissipation capability of 150mW at T_A=25°C with the derating factor of -1.2mW / °C.

The table below summarizes the maximum power dissipation capability of each package versus ambient temperature.

Pkg	Ambient Temperature (T _A) °C				
	25	40	50	60	70
SOT-23	150mW	132mW	120mW	108mW	96mW

In our previous example, the maximum power dissipation of the device is calculated under no load and maximum input supply condition.

The maximum power is calculated using the following equation:

$$P_{MAX} = V_{KA} \times \left(\frac{V_{MAX} - V_{KA}}{R_B} \right)$$

Where:

P_{MAX} = Maximum power dissipation of the IRU431L

For our example:

$$P_{MAX} = 3.3 \times \left(\frac{6 - 3.3}{100} \right) = 89mW$$

As shown in the power dissipation table, both packages can handle this power dissipation.

Stability

The IRU431L has many different domains of stability as a function of the cathode current. As is typical of three-terminal shunt regulators, the IRU431L has many domains of stability. The actual domain in which any practical circuit operates is related to cathode current. In general the device will be unconditionally stable for any cathode current if a capacitor, 1µF or larger, is connected between the cathode and the anode. If the cathode current is always higher than 3mA under minimum line and maximum load conditions, the capacitor value can be reduced to 0.01µF and the system will be stable.

TYPICAL APPLICATION

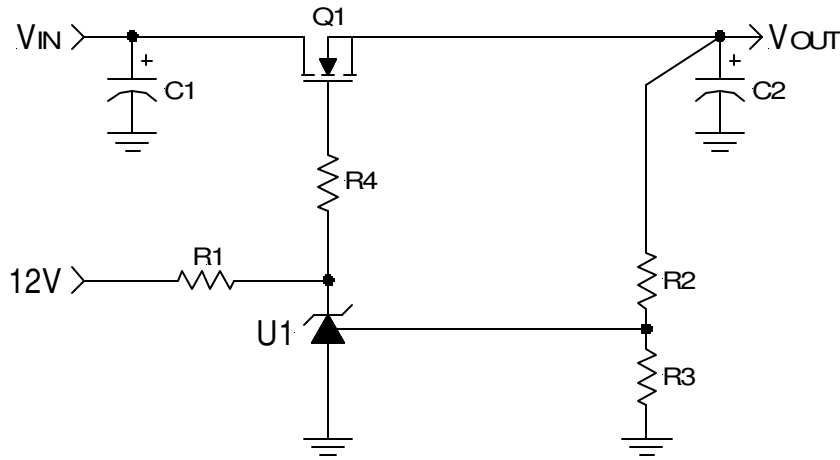
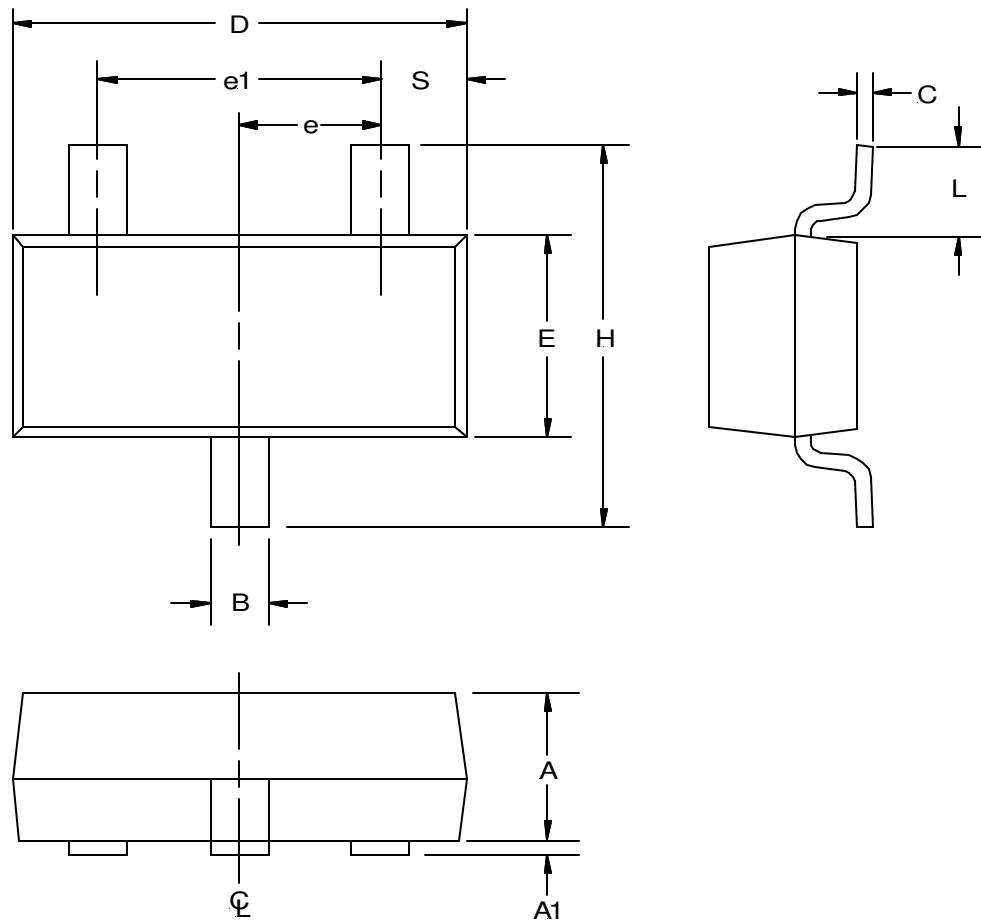

Figure 4 - Low cost 3.3V to 2.7V output.

Ref Desig	Description	Qty	Part #	Manuf
U1	Shunt Regulator	1	IRU431L	IR
C1, C2	Capacitor	2	Elect, 220 μ F, 6.3V, ECAOJFQ221	Panasonic
R1	Resistor	1	6.2K Ω , 5%, SMT	
R2	Resistor	1	118 Ω , 1%, SMT	
R3, R4	Resistor	2	100 Ω , 1%, SMT	
HS1	Heat Sink	Use minimum of 1" square copper pad area for load current <4A		

**(L3) SOT-23 Package
 3-Pin**



SYMBOL	MIN	MAX
A	0.890	1.120
A1	0.013	0.100
B	0.370	0.510
C	0.085	0.180
D	2.800	3.040
E	1.200	1.400
e	0.890	1.030
e1	1.780	2.050
H	2.100	2.640
L	0.55 REF	
S	0.450	0.600

NOTE: ALL MEASUREMENTS
 ARE IN MILLIMETERS.

(L5) SOT-23 Package
 5-Pin

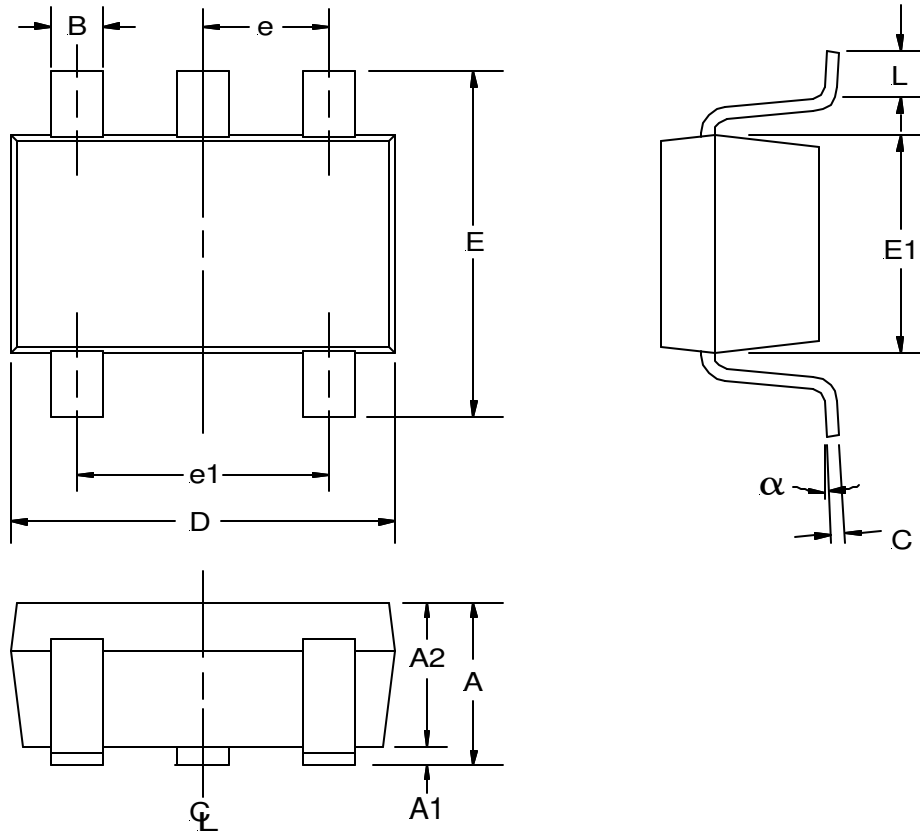

SYMBOL	MIN	MAX
A	0.90	1.45
A1	0.00	0.15
A2	0.90	1.30
B	0.25	0.50
C	0.09	0.20
D	2.80	3.00
E	2.60	3.00
E1	1.50	1.75
e	0.95 REF	
e1	1.90 REF	
L	0.35	0.55
α	0°	10°

NOTE: ALL MEASUREMENTS
 ARE IN MILLIMETERS.

PACKAGE SHIPMENT METHOD

PKG DESIG	PACKAGE DESCRIPTION	PIN COUNT	PARTS PER TUBE	PARTS PER REEL	T & R Orientation
L3	SOT-23	3	---	3000	Fig A
L5	SOT-23	5	---	3000	Fig B

