

REVISIONS			
REV	DESCRIPTIONS	DATE	APPROVED
L	ECO 52611	9/28/10	T. KOHLER

DASH NO	CABLES ACCOMMODATED	ASSEMBLE PER	A DIA
-7	TRC-50-2/TRC-75-2	TAI-189	.274
-9	TWC-78-2/TWC-124-2	TAI-102	.285
-23	250-3884, MICROOOT	TAI-189	.183
-24	202-3934, MICROOOT	TAI-102	.191
-24A	9530A5117, RAYCHEM	TAI-189	.200
-25	GEE1A, GERMANY	TAI-102	.285
-25A	5021H5331, RAYCHEM	TAI-189	.285
-26	702BA5518, RAYCHEM		.183
-27	202-3927, MICROOOT		.145
-29	TWC-78-1/TWC-124-1A	TAI-102	.191
-30	761A,W.E.CO/8441,BELDEN		.235
-32	TRC-50-1		.191
-33	TRC-75-1		.217
-42	21-204, ESSEX 4463, CONSOLIDATED	TAI-189	.300
-43	250-4044/250-4045 293-3930, MICROOOT		.200
-45	M27500-22TE2T14 1100-66F, STANDARD		.183
-47	MI7/176-00002	TAI-102	.164
-49	TWAC-78-1F2		.132
-55	89272, BELDEN		.250
-56	GC875GC1, GRUMMAN	TAI-189	.191
-57	GC875GB1, GRUMMAN		
-58	GC875TM24H, GRUMMAN	TAI-102	.198
-59	GC875LNI, GRUMMAN		
-60	MI7/177, THERMATICS 380-10045, BOEING	TAI-189	.217
-64	7528A5314, RAYCHEM		.183

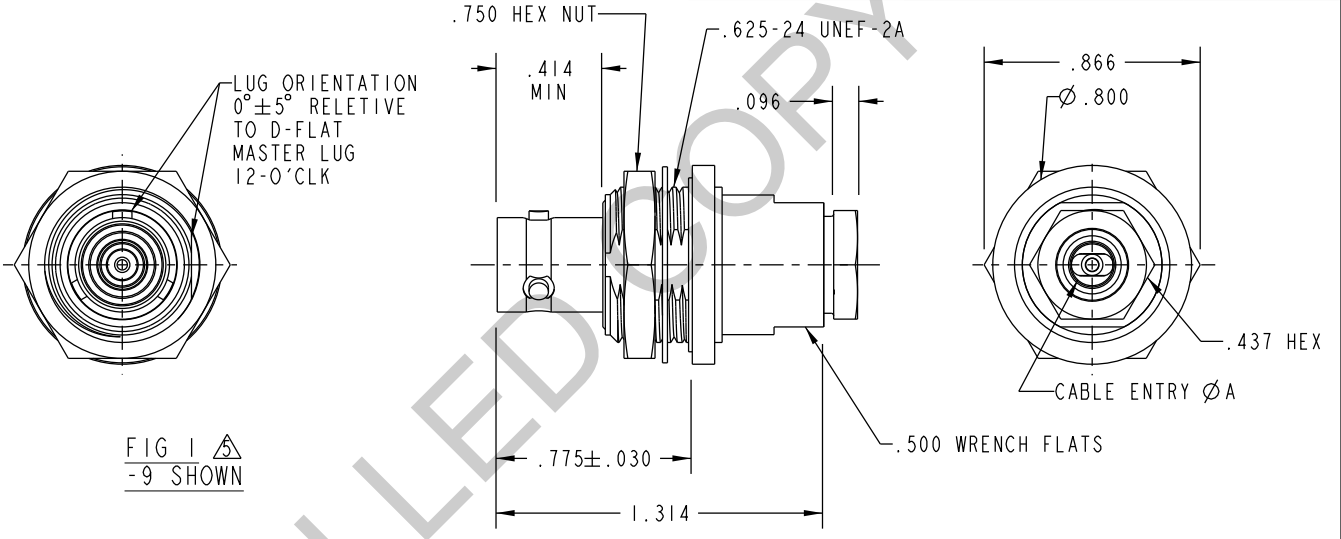

FIG 1 -9 SHOWN

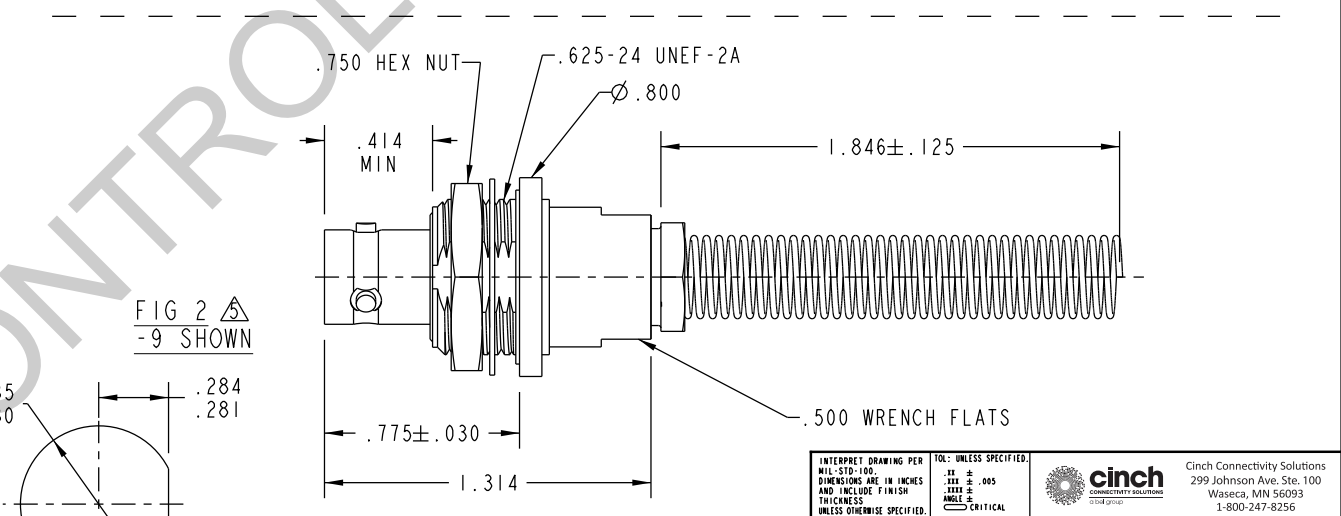
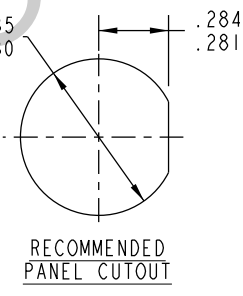

FIG 2 -9 SHOWN



- IF BEND RELIEF SPRING REQUIRED (FIG 2)
- 4. CONCENTRIC TWINAX/TRIAX TRB BULKHEAD MOUNT CABLE RECEPTACLE
- 3. MAX PANEL THK .140
- 2. FINISH: TFS-1A (NICKEL)
- 1. ALL DIM ARE IN INCHES

NOTES: UNLESS OTHERWISE SPECIFIED.

INTERPRET DRAWING PER MIL-STD-100. DIMENSIONS ARE IN INCHES AND INCLUDE FINISH THICKNESS UNLESS OTHERWISE SPECIFIED.		TOL: UNLESS SPECIFIED.		TITLE: B J74/B J74BR	
DRN: J. CRAWFORD 10/19/10		FIN: ± .005		CINCINNATI CONNECTIONS SOLUTIONS	
CHN: C. WALLACE 10/19/10		MATERIAL:		299 Johnson Ave. Ste. 100 Waseca, MN 56093 1-800-247-8256	
BLANK LENGTH (REF. ONLY)		FINISH:		SIZE: B 14949	
APPROVED:		DATE:		DRAWING NO. 3-0055	
SURFACE AREA		DO NOT SCALE DWG		SCALE: 2/1	
PROJ. FILE NO. 3-0055		DATE:		SHEET 1 OF 2	