

PART NUMBER	REVISION	DESCRIPTION	FEED TYPE
2151107-2	F	FINE CRIMP HEIGHT ADJUST	PNEUMATIC
7-2151107-2	F	PNEUMATIC AND CRIMP TOOLING KIT	PNEUMATIC
7-2151107-7	A	CRIMP TOOLING KIT	-

ATLANTIC VERSION TERMINATOR INTERFACE ADAPTER

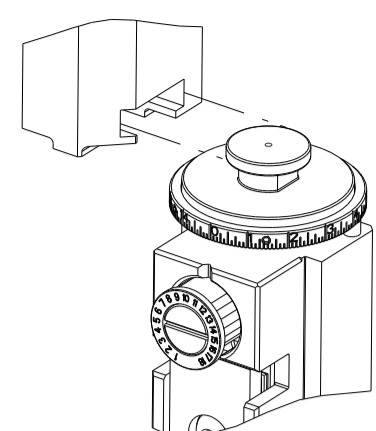

APPLICATOR DATA		
CRIMP	SIZE	TYPE
WIRE	2.79 mm [.110]	F
INSUL	3.55 mm [.140]	OV

APPLICATOR INSTRUCTIONS 408-35042

TERMINAL DATA: TE TERMINAL		TE CRIMP SPECIFICATION	
TERMINAL NAME: POSITIVE LOCK RECEPTACLE			
WIRE STRIP LENGTH 5.70-6.30 mm [.224-.248 IN]		INSULATION DIAMETER RANGE Ø2.10-3.10 mm [.083-.122 IN]	
TERMINAL APPLICATION SPECIFICATION	114-18365	-	-
TERMINALS APPLIED			
TE TERMINAL	TE TERMINAL	TE TERMINAL	TE TERMINAL
927854-1	927854-2	927854-3	927854-6
927854-7	927854-8	927854-9	

WIRE SIZE	CRIMP HEIGHT mm [INCH]	CRIMP HEIGHT REFERENCE SETTING
2.50mm2	2.04 +/- 0.05 [.080 +/- .002]	6.6
2.00mm2	1.90 +/- 0.05 [.075 +/- .002]	8.4
1.50mm2	1.76 +/- 0.05 [.069 +/- .002]	10.1

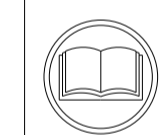

- RECOMMENDED SPARE PARTS
  - REFER TO SUPPLIED INSTRUCTION SHEET FOR CLEANING, LUBRICATION AND STORAGE OF APPLICATOR.
  - APPLY PART NUMBER 2-23419-6 LOCTITE TO THREADS OF ITEM 242.
  - CRIMP HEIGHT REFERENCE SETTING WAS THE SETTING USED WHEN THE APPLICATOR WAS QUALIFIED AT THE FACTORY. ADJUSTMENT MAY BE NECESSARY WHEN RUNNING APPLICATOR IN THE FIELD.
  - TERMINAL PITCH NOT COMPATIBLE WITH MECHANICAL FEED.
  - TERMINAL LUBRICANT IS RECOMMENDED.
7. UNLESS SPECIFIED OTHERWISE TORQUE VALUES SHALL BE USED PER DOCUMENT, 101-35000.

**\*WARNING**  
ON INSTALLATION, SET WIRE DISC TO CRIMP HEIGHT REFERENCE SETTING FOR LARGEST WIRE SIZE. CRIMP HEIGHT REFERENCE SETTINGS GREATER THAN THE VALUE SHOWN MAY CAUSE DAMAGE TO THE CRIMP TOOLING. REFER TO THE INSTRUCTION SHEET FOR PROPER SETUP AND ADJUSTMENTS.

LOC	DIST	REVISIONS			
A	66	REV	DATE	BY	APPV
		C	ECR-18-007903	23MAY2018	YY JDG
		D	ECR-18-019058	05DEC2018	MZ CT
		E	ECR-19-005860	11APR2019	FJ TE
		F	ECR-23-164811	28JAN2023	FZ GB

-	1	1	2119641-1	FEED CAM, AIR FEED	248
-	1	1	2119082-9	CAM, SNAIL, INSULATION ADJUSTMENT	244
-	1	1	2079764-1	WASHER, WAVE SPRING, CREST-TO-CREST	243
-	1	1	2119083-1	RETAINER, INSULATION DIAL	242
-	1	1	7-18023-7	SCR, SKT HD CAP M3 X 4.0	241
-	1	1	2844940-2	AIR FEED MODULE	238
-	REF	REF	994970-2	COUNTER, MAGNETIC	164
-	1	1	318563-1	GUARD, FRONT CHIP	119
-	1	1	2119955-1	ASSY, LUBRICATOR, SIDE FEED	113
-	1	1	2844908-1	SCREW, LOCKING	99
-	1	1	2844907-1	POST, LOCKING	98
-	1	1	455888-6	SPACER, CRIMPER	82
-	1	1	1803607-3	DOCUMENTATION PACKAGE	71
-	1	1	2119740-1	TAG, IDENTIFICATION	67
-	2	2	2168078-1	SCREW, DRIVE, RH, RoHS, 2 x .188	66
-	1	1	2168083-2	SCR, SKT HD CAP, RoHS, M4 X 8.0	60
-	1	1	5-18022-5	SCR, HEX HD CAP, M4 X 6.0	59
-	1	1	1338685-1	PAWL, FEED	56
-	4	4	2168083-3	SCR, SKT HD CAP, RoHS, M4 X 12.0	54
-	2	2	2168083-3	SCR, SKT HD CAP, RoHS, M4 X 12.0	53
-	1	1	1803382-6	HOLD DOWN, SPRING LOADED	50
-	1	1	18023-9	SCR, SKT HD CAP M4 X 6.0	49
-	1	1	1803583-9	APPLICATOR BASIC ASSEMBLY, SF	46
-	1	1	1803515-1	RAM ASSEMBLY, SF ATLANTIC	44
-	1	1	1803602-1	SCR, BHSC, RoHS (M8 X 25)	41
-	1	1	1-1752356-8	SUPPORT, TERMINAL	34
-	2	2	2079383-5	SCR, BHSC, RoHS (M4 X 20)	33
-	2	2	3-2844962-0	SPACER, CYLINDRICAL, STRIP GUIDE	30
-	1	1	2844992-1	ASSEMBLY, STRIP GUIDE	29
-	1	1	1-455888-0	SPACER, CRIMPER	28
-	1	1	1320928-2	STRIP GUIDE	24
-	1	1	2168083-2	SCR, SKT HD CAP, RoHS, M4 X 8.0	21
-	1	1	1-18028-2	WASHER, FLAT, REG M4	20
-	1	1	2119533-1	STRIPPER, SIDE FEED	19
-	1	1	2119806-1	INSERT, SHEAR	13
-	1	1	4-22280-8	SPRING, COMPRESSION	12
-	1	1	1-356885-4	STOP, SHEAR	11
-	1	1	2119805-1	SHEAR HOLDER, FRONT	10
-	1	1	454276-5	FLOATING SHEAR, FRONT	9
-	1	2	1338696-1	ANVIL, COMBINATION	8
-	1	1	1-240641-6	SPACER	7
-	1	1	2119757-8	DEPRESSOR, SHEAR	5
-	1	1	2-238011-2	BLOCK, CRIMPER SPACER	4
-	1	2	1633963-2	CRIMPER, INSULATION OVERLAP PREMIUM	3
-	1	1	1-455888-0	SPACER, CRIMPER	2
-	1	2	6-456408-0	CRIMPER, WIRE PREMIUM	1

ATLANTIC VERSION  
Shown on sheets 1 of 4 & 2 of 4  
(Pacific version shown on sheets 3 of 4 & 4 of 4)

DIMENSIONS:		TOLERANCES UNLESS OTHERWISE SPECIFIED:		MATERIAL:		FINISH:		WEIGHT:		SCALE:		SHEET:		REV:	
mm	0 PLC ±	1 PLC ±	2 PLC ±	3 PLC ±	4 PLC ±	ANGLES	FINISH			A1	00779	2151107	1	4	F

LOC		DIST		REVISIONS			
A	66	P	LTN	DESCRIPTION	DATE	OWN	APVD
		-		SEE SHEET 1	-	-	-

# FEED TYPE

## PNEUMATIC

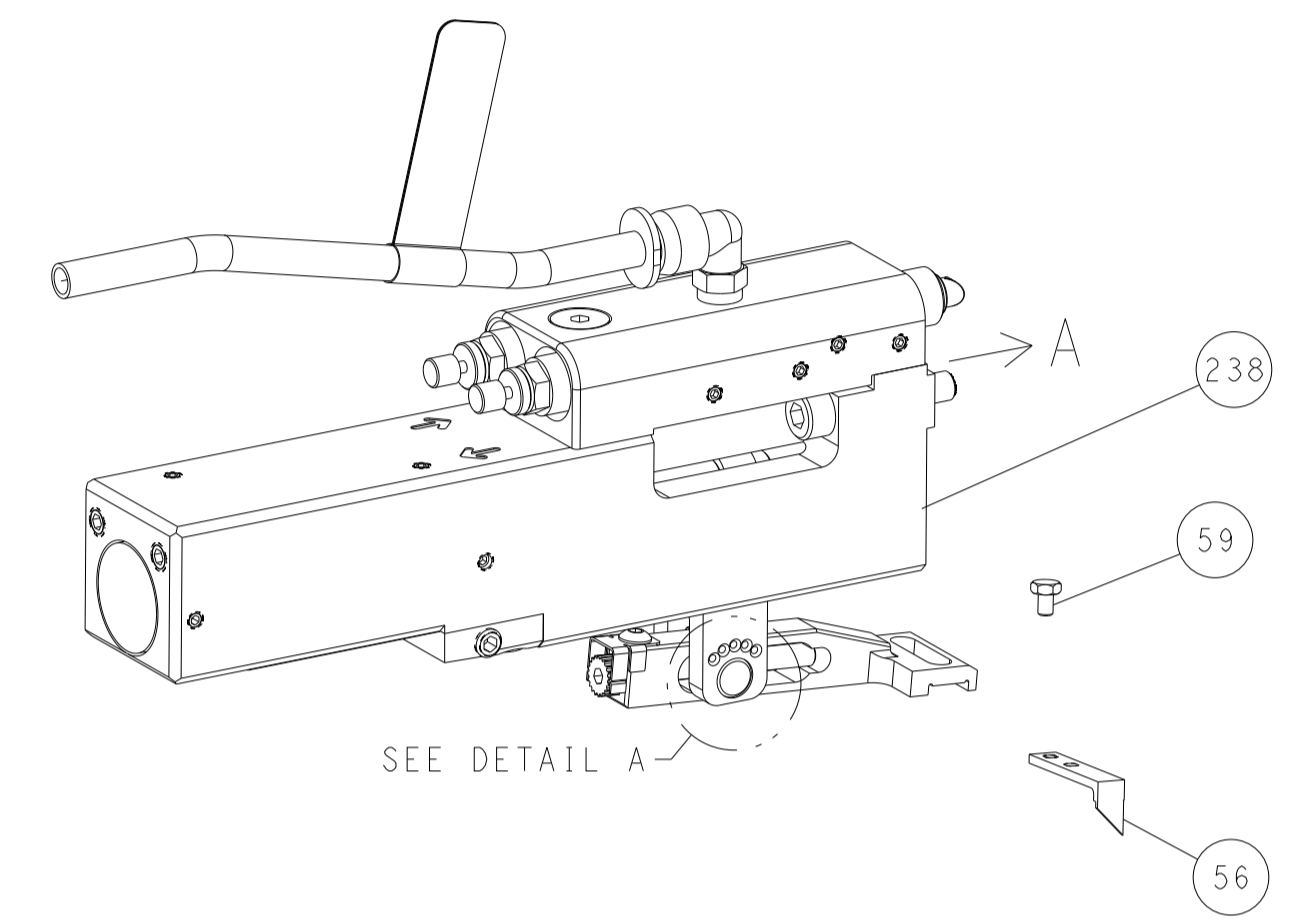

## FEED SPRING SETTING POSITION (SHOWN FROM REAR SIDE)

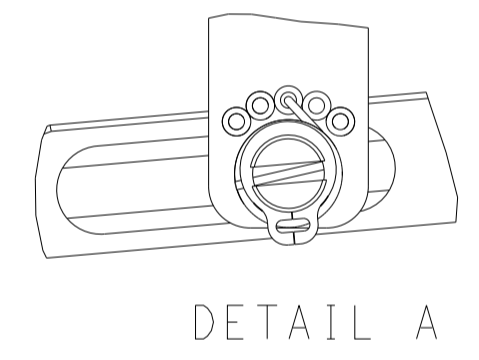

DETAIL A

## CAM POSITION

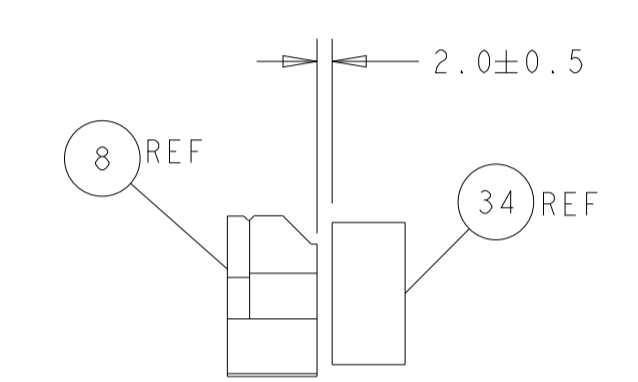
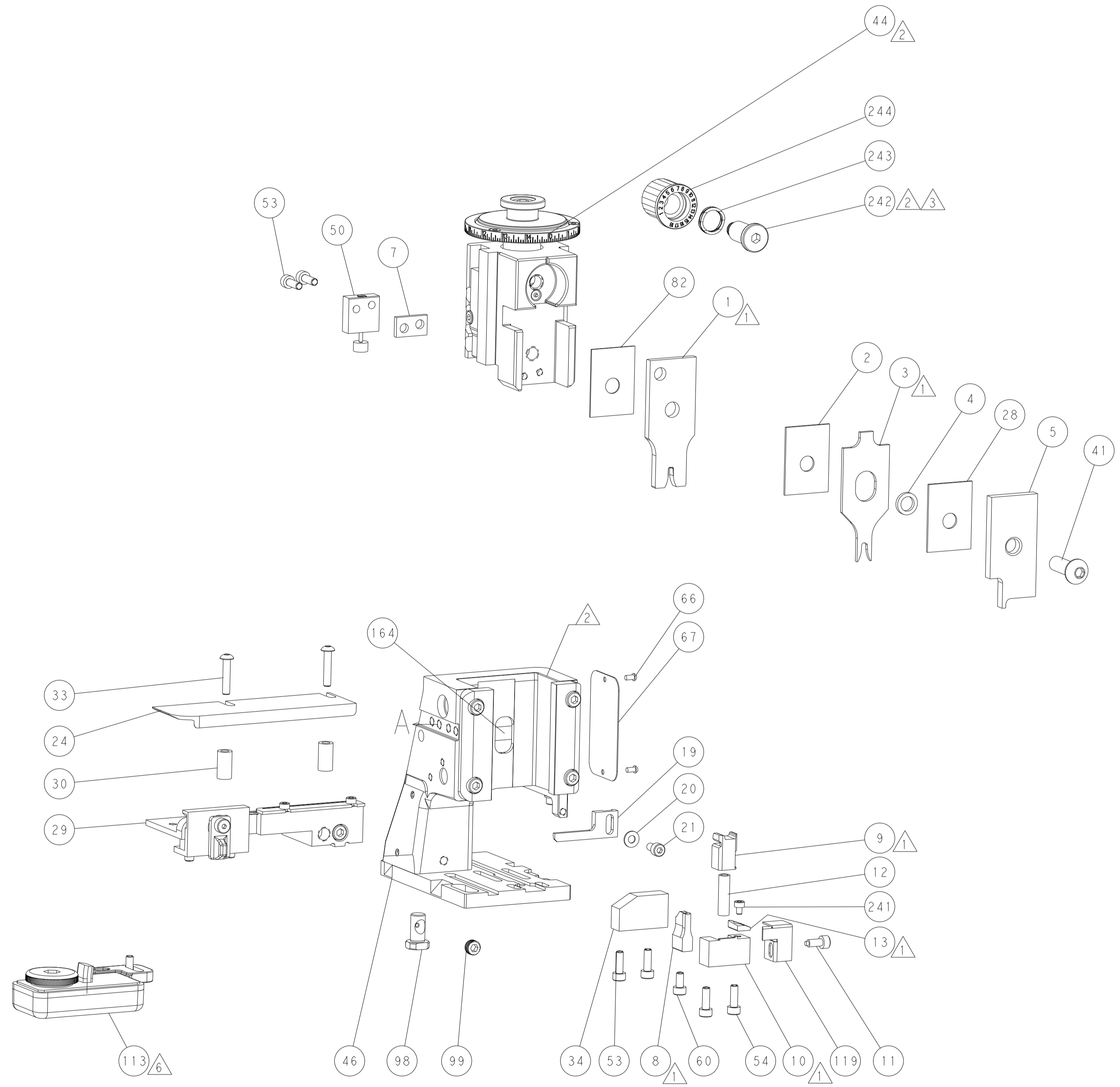
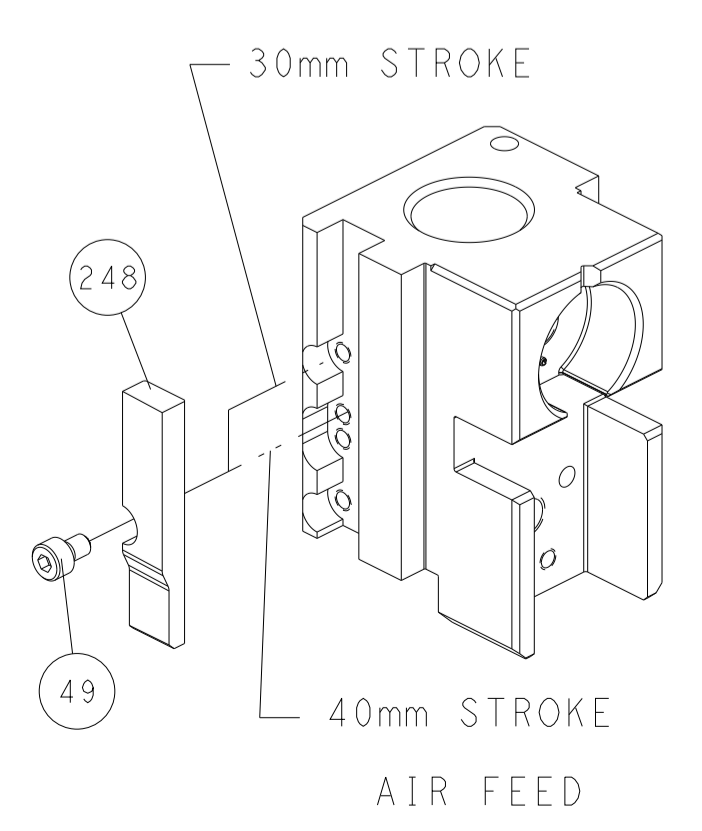

TERMINAL SUPPORT LOCATION

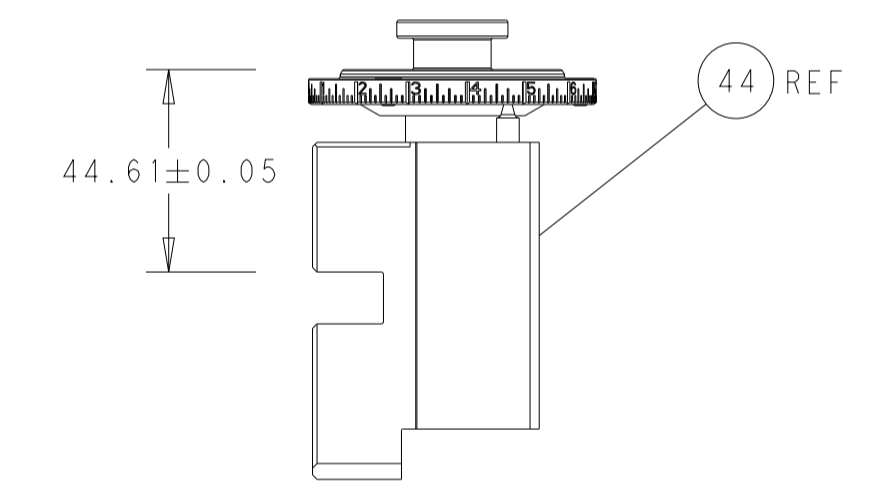

RAM SET-UP

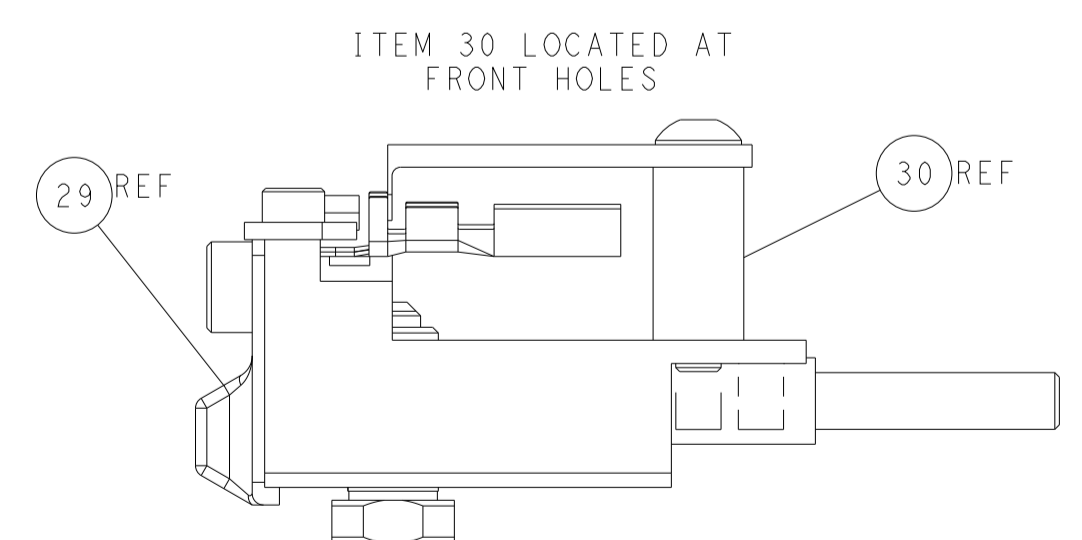

FEED TRACK POSITION GUIDE BY INSULATION BARREL

**ATLANTIC VERSION**  
 Shown on sheets 1 of 4 & 2 of 4  
 (Pacific version shown on sheets 3 of 4 & 4 of 4)

<small>THIS DRAWING IS UNPUBLISHED. RELEASED FOR PUBLICATION BY TYCO ELECTRONICS CORPORATION. ALL RIGHTS RESERVED.</small>		DWN: S_ZOU 02JUN2011 CHK: G_BAILEY 02JUN2011 APVD: S_XI 02JUN2011	NAME: Ocean Side Feed Applicator SIZE: A1 CAGE CODE: 00779 DRAWING NO: C=2151107	TE Connectivity Harrisburg, PA 17105-3608
DIMENSIONS: mm TOLERANCES UNLESS OTHERWISE SPECIFIED: 0 PLC ± 1 PLC ± 2 PLC ± 3 PLC ± 4 PLC ± ANGLES ± FINISH	MATERIAL:	WEIGHT:	RESTRICTED TO:	SCALE: 1:2 SHEET: 2 OF 4 REV: F

PART NUMBER	REVISION	DESCRIPTION	FEED TYPE
2-2151107-2	F	FINE CRIMP HEIGHT ADJUST	PNEUMATIC
7-2151107-7	A	CRIMP TOOLING KIT	-

PACIFIC VERSION TERMINATOR  
 INTERFACE ADAPTER

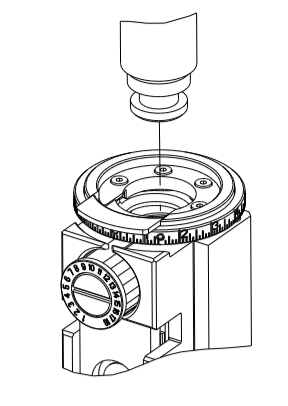

APPLICATOR DATA		
CRIMP	SIZE	TYPE
WIRE	2.79 mm [.110]	F
INSUL	3.55 mm [.140]	OV
APPLICATOR INSTRUCTIONS 408-35042		

TERMINAL DATA: TE TERMINAL		TE CRIMP SPECIFICATION	
TERMINAL NAME: POSITIVE LOCK RECEPTACLE			
WIRE STRIP LENGTH		INSULATION DIAMETER RANGE	
5.70-6.30 mm [.224-.248 IN]		Ø2.10-3.10 mm [.083-.122 IN]	
TERMINAL APPLICATION SPECIFICATION		114-18365	-
TERMINALS APPLIED			
TE TERMINAL	TE TERMINAL	TE TERMINAL	TE TERMINAL
927854-1	927854-2	927854-3	927854-6
927854-7	927854-8	927854-9	

WIRE SIZE	CRIMP HEIGHT mm [INCH]	CRIMP HEIGHT REFERENCE SETTING
2.50mm2	2.04 +/- 0.05 [.080 +/- .002]	6.6
2.00mm2	1.90 +/- 0.05 [.075 +/- .002]	8.4
1.50mm2	1.76 +/- 0.05 [.069 +/- .002]	10.1

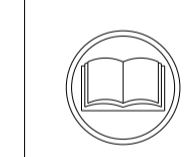

- 1 RECOMMENDED SPARE PARTS
  - 2 REFER TO SUPPLIED INSTRUCTION SHEET FOR CLEANING, LUBRICATION AND STORAGE OF APPLICATOR.
  - 3 APPLY PART NUMBER 2-23419-6 LOCTITE TO THREADS OF ITEM 242.
  - 4 CRIMP HEIGHT REFERENCE SETTING WAS THE SETTING USED WHEN THE APPLICATOR WAS QUALIFIED AT THE FACTORY. ADJUSTMENT MAY BE NECESSARY WHEN RUNNING APPLICATOR IN THE FIELD.
  - 5 TERMINAL PITCH NOT COMPATIBLE WITH MECHANICAL FEED.
  - 6 TERMINAL LUBRICANT IS RECOMMENDED.
7. UNLESS SPECIFIED OTHERWISE TORQUE VALUES SHALL BE USED PER DOCUMENT, 101-35000.

**\*WARNING**  
 ON INSTALLATION, SET WIRE DISC TO CRIMP HEIGHT REFERENCE SETTING FOR LARGEST WIRE SIZE. CRIMP HEIGHT REFERENCE SETTINGS GREATER THAN THE VALUE SHOWN MAY CAUSE DAMAGE TO THE CRIMP TOOLING, REFER TO THE INSTRUCTION SHEET FOR PROPER SETUP AND ADJUSTMENTS.

LOC	DIST	REVISIONS					
		P	LTN	DESCRIPTION	DATE	OWN	APVD
A	66	-	-	SEE SHEET 1	-	-	-

-	1	2119082-9	CAM, SNAIL, INSULATION ADJUSTMENT	244	
-	1	2079764-1	WASHER, WAVE SPRING, CREST-TO-CREST	243	
3	-	1	2119083-1	RETAINER, INSULATION DIAL	242
-	1	7-18023-7	SCR, SKT HD CAP M3 X 4.0	241	
-	1	2844940-2	AIR FEED MODULE	238	
-	REF	994970-2	COUNTER, MAGNETIC	164	
-	1	2119641-2	FEED CAM, AIR FEED	151	
-	1	2168083-8	SCR, SKT HD CAP, RoHS, M4 X 16	144	
-	4	2168083-9	SCR, SKT HD CAP, RoHS, M4 X 20	143	
-	1	1-1803583-0	APPLICATOR BASIC ASSEMBLY, SF	141	
-	1	1803516-1	RAM ASSEMBLY, SF PACIFIC	140	
-	1	318563-1	GUARD, FRONT CHIP	119	
6	-	1	2119955-1	ASSY, LUBRICATOR, SIDE FEED	113
-	1	2844908-1	SCREW, LOCKING	99	
-	1	2844907-1	POST, LOCKING	98	
-	1	455888-6	SPACER, CRIMPER	82	
-	1	1803607-3	DOCUMENTATION PACKAGE	71	
-	1	2119740-1	TAG, IDENTIFICATION	67	
-	2	2168078-1	SCREW, DRIVE, RH, RoHS, 2 x .188	66	
-	1	5-18022-5	SCR, HEX HD CAP, M4 X 6.0	59	
-	1	1338685-1	PAWL, FEED	56	
-	2	2168083-3	SCR, SKT HD CAP, RoHS, M4 X 12.0	53	
-	1	1803382-6	HOLD DOWN, SPRING LOADED	50	
-	1	18023-9	SCR, SKT HD CAP M4 X 6.0	49	
-	1	1803602-1	SCR, BHSC, RoHS (M8 X 25)	41	
-	1	1-1752356-8	SUPPORT, TERMINAL	34	
-	2	2079383-5	SCR, BHSC, RoHS (M4 X 20)	33	
-	2	3-2844962-0	SPACER, CYLINDRICAL, STRIP GUIDE	30	
-	1	2844992-1	ASSEMBLY, STRIP GUIDE	29	
-	1	1-455888-0	SPACER, CRIMPER	28	
-	1	1320928-2	STRIP GUIDE	24	
-	1	2168083-2	SCR, SKT HD CAP, RoHS, M4 X 8.0	21	
-	1	1-18028-2	WASHER, FLAT, REG M4	20	
-	1	2119533-1	STRIPPER, SIDE FEED	19	
-	1	2119806-1	INSERT, SHEAR	13	
1	-	1	4-22280-8	SPRING, COMPRESSION	12
-	1	1-356885-4	STOP, SHEAR	11	
-	1	2119805-1	SHEAR HOLDER, FRONT	10	
1	-	1	454276-5	FLOATING SHEAR, FRONT	9
1	1	1	1338696-1	ANVIL, COMBINATION	8
1	-	1	1-240641-6	SPACER	7
-	1	2119757-8	DEPRESSOR, SHEAR	5	
-	1	2-238011-2	BLOCK, CRIMPER SPACER	4	
1	1	1	1633963-2	CRIMPER, INSULATION OVERLAP PREMIUM	3
-	1	1	1-455888-0	SPACER, CRIMPER	2
1	1	1	6-456408-0	CRIMPER, WIRE PREMIUM	1
-	77	-22	PART NO	DESCRIPTION	ITEM NO

PACIFIC VERSION  
 Shown on sheets 3 of 4 & 4 of 4  
 (Atlantic version shown on sheets 1 of 4 & 2 of 4)

DIMENSIONS: mm 		TOLERANCES UNLESS OTHERWISE SPECIFIED: 0 PLC ± 1 PLC ± 2 PLC ± 3 PLC ± 4 PLC ± ANGLES ° FINISH		DWG S.ZOU 02JUN2011 CHK G.BAILEY 02JUN2011 APVD S.XI 02JUN2011 PRODUCT SPEC APPLICATION SPEC WEIGHT SCALE 1:2 SHEET 3 OF 4 REV F		NAME Ocean Side Feed Applicator SIZE CAGE CODE DRAWING NO A1 00779 C=2151107 RESTRICTED TO Customer Accessible Production Drawing	
-----------------------	--	---	--	--	--	---	--

LOC	DIST	REVISIONS			
P	LTN	DESCRIPTION	DATE	OWN	APVD
A	66	SEE SHEET 1	-	-	-

# FEED TYPE

## PNEUMATIC

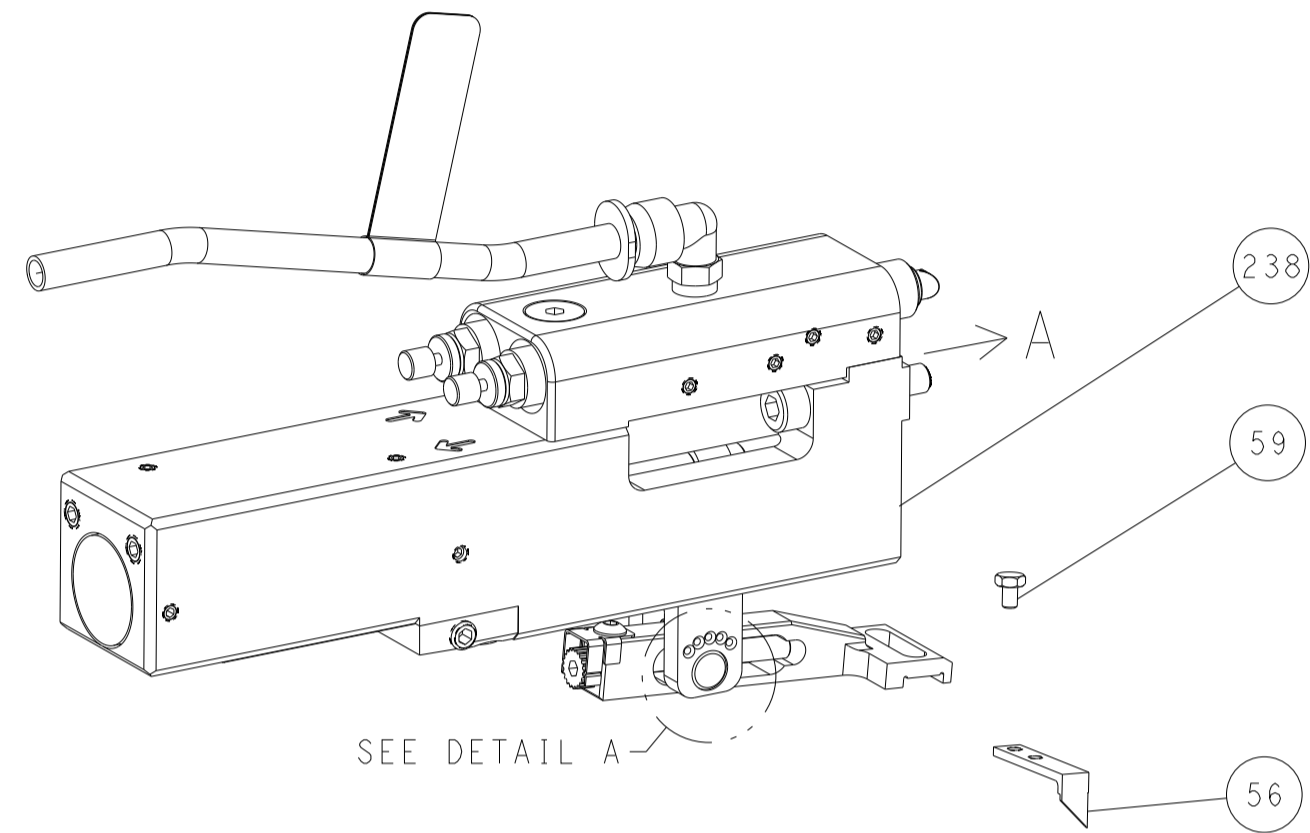

## FEED SPRING SETTING POSITION (SHOWN FROM REAR SIDE)

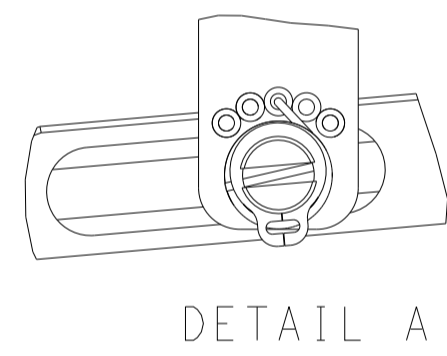

## CAM POSITION

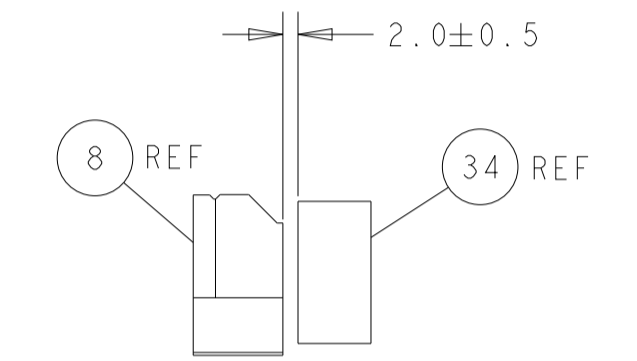
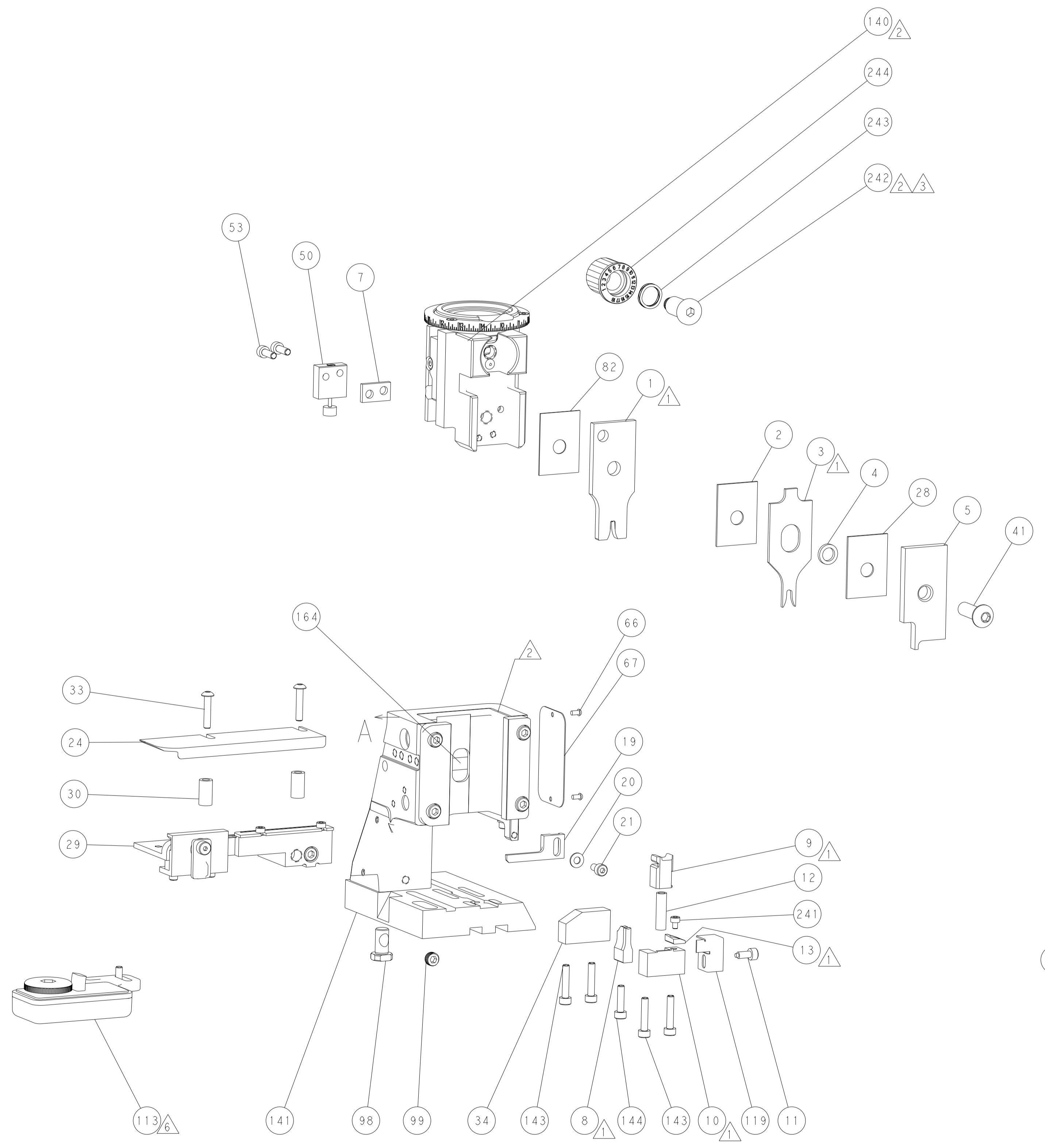
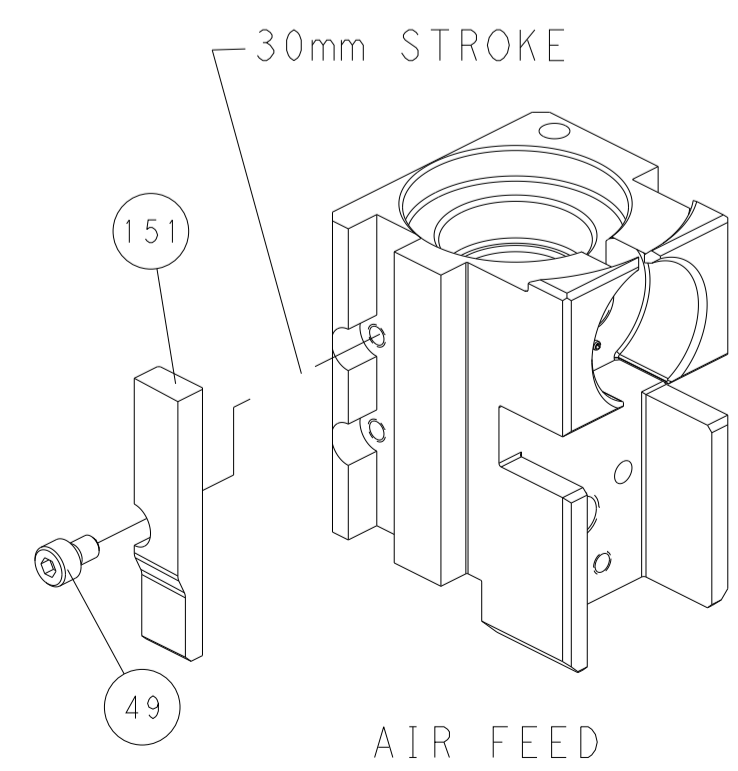

TERMINAL SUPPORT LOCATION

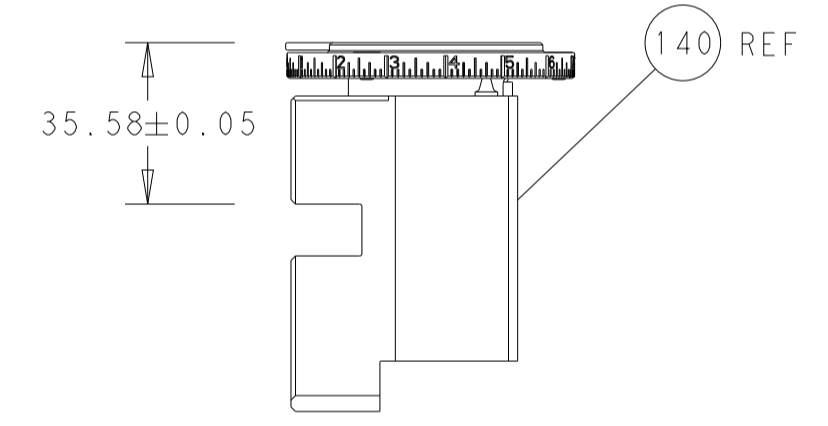

RAM SET-UP

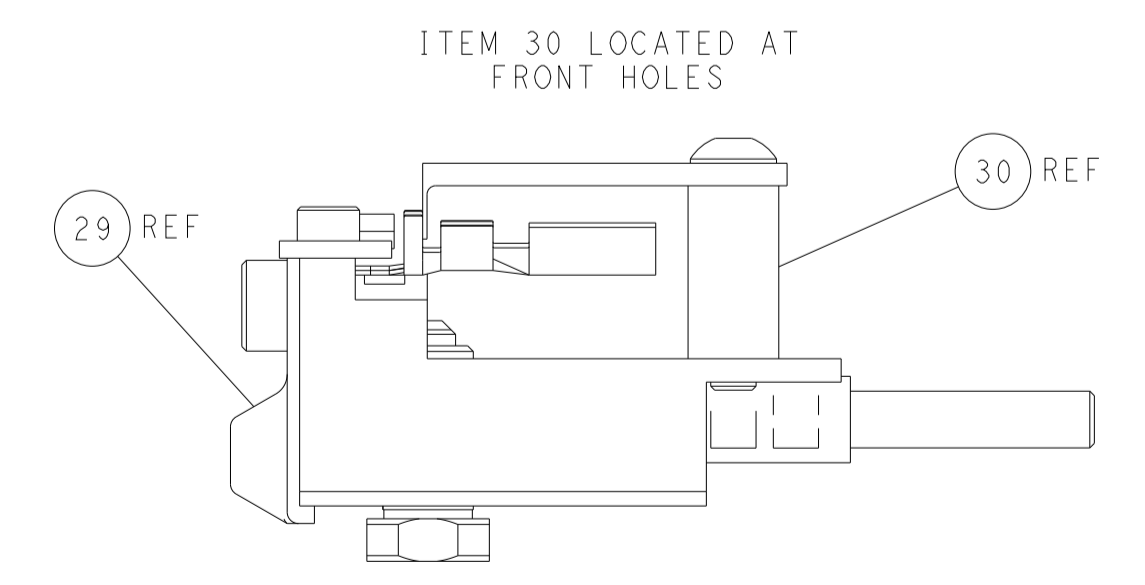

FEED TRACK POSITION GUIDE BY INSULATION BARREL

**PACIFIC VERSION**  
 Shown on sheets 3 of 4 & 4 of 4  
 (Atlantic version shown on sheets 1 of 4 & 2 of 4)

<small>THIS DRAWING IS A CONTROLLED DOCUMENT FOR TYCO ELECTRONICS CORPORATION. IT IS THE PROPERTY OF COMPANY AND IS NOT TO BE REPRODUCED OR TRANSMITTED IN ANY FORM OR BY ANY MEANS, ELECTRONIC OR MECHANICAL, INCLUDING PHOTOCOPYING, RECORDING, OR BY ANY INFORMATION STORAGE AND RETRIEVAL SYSTEM, WITHOUT THE WRITTEN PERMISSION OF TYCO ELECTRONICS CORPORATION.</small>		DWN S. ZOU 02JUN2011 CHK G. BAILEY 02JUN2011 APVD S. XI 02JUN2011	NAME Ocean Side Feed Applier
DIMENSIONS: mm TOLERANCES UNLESS OTHERWISE SPECIFIED: 0 PLC ± 1 PLC ± 2 PLC ± 3 PLC ± 4 PLC ± ANGLES ± FINISH ±	WEIGHT SCALE 1:2 SHEET 4 OF 4 REV F	SIZE A1 CAGE CODE 00779 DRAWING NO C=2151107	RESTRICTED TO Customer Accessible Production Drawing