

LT3579/LT3579-1: Boost/Inverting DC/DC Converter

DESCRIPTION

Demonstration circuit 1661A features the LT[®]3579 and LT3579-1 in a parallel boost regulator configuration. The circuit is designed to convert a 5V to 10V input source to 12V at 3.5A. DC1661A is designed to survive output short circuit events with an external disconnect MOSFET at the output as default. The circuit board includes an option to install the disconnect MOSFET at the input side. To use it, install Q1 and R2 on the back of the board, place a jumper from Q2 source to drain and cut top copper as shown in Figure 3. The circuit board can also be used to supply two separate output voltages. Cut trace as shown in Figure 3 remove R13 and R14, and set feedback and VC components as needed. The LT3579 includes a 42V master and slave switch combination with 6A total current and can be

used in many configurations such as boost, SEPIC, cuk and flyback. It has a 2.5V to 16V operating input range, UVLO, soft-start, programmable switching frequency and many other popular features. The LT3579 data sheet gives a complete description of the part, its operation and application information. The data sheet must be read in conjunction with this quick start guide for working on or modifying the demo circuit 1661A.

Design files for this circuit board are available at <http://www.linear.com/demo>

LT, LT, LTC, LTM, Linear Technology and the Linear logo are registered trademarks of Linear Technology Corporation. All other trademarks are the property of their respective owners.

PERFORMANCE SUMMARY (T_A = 25°C)

SYMBOL	PARAMETER	CONDITIONS	MIN	TYP	MAX	UNITS
V _{IN}	Input Supply Range		5		10	V
V _{OUT}	Output Voltage Accuracy	V _{IN} = 5V to 10V, I _{LOAD} = 3.5A	11.60	12	12.30	V
Efficiency		V _{IN} = 5V, I _{LOAD} = 3.5A		83		%
Efficiency		V _{IN} = 10V, I _{LOAD} = 3.5A		92		%
Ripple		V _{IN} = 5V, I _{LOAD} = 3.5A		50		mV
F _S	Switching Frequency			1		MHz

DEMO MANUAL DC1661A

QUICK START PROCEDURE

Demonstration circuit 1661A is easy to set up to evaluate the performance of the LT3579/LT3579-1. Refer to Figure 1 and Figure 2 for proper measurement equipment set-up and follow the procedure below:

To measure the input or output voltage ripple, care must be taken to avoid a long ground lead on the oscilloscope probe. Measure the input or output voltage ripple by touching the probe tip directly across the V_{IN} or V_{OUT} and GND terminals. See Figure 2 for proper scope probe technique.

1. Place jumper in the following position:
JP1 On
2. With power off, connect the input power supply to V_{IN} and GND.

Apply 7.5V to input (source must have >12A capability).
Check for the proper output voltages.

NOTE. If there is no output, temporarily disconnect the load to make sure that the load is not set too high.

Once the proper output voltage is established, adjust the load within the operating range and observe the output voltage regulation, ripple voltage, efficiency and other parameters.

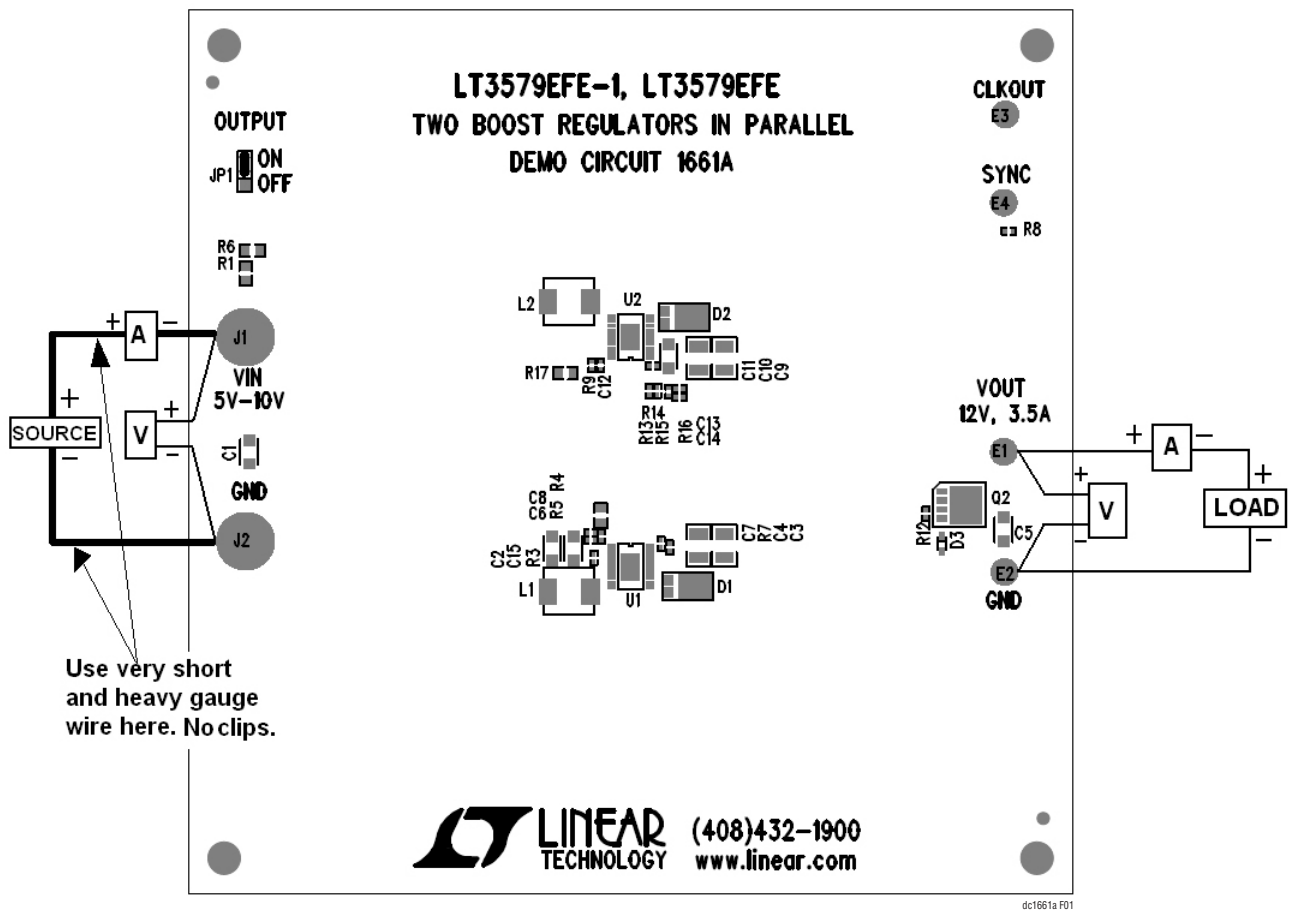

Figure 1. DC1661A Proper Equipment Set-Up

QUICK START PROCEDURE

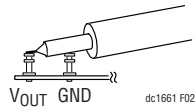

Figure 2. Proper Input/Output Ripple Measurement Technique

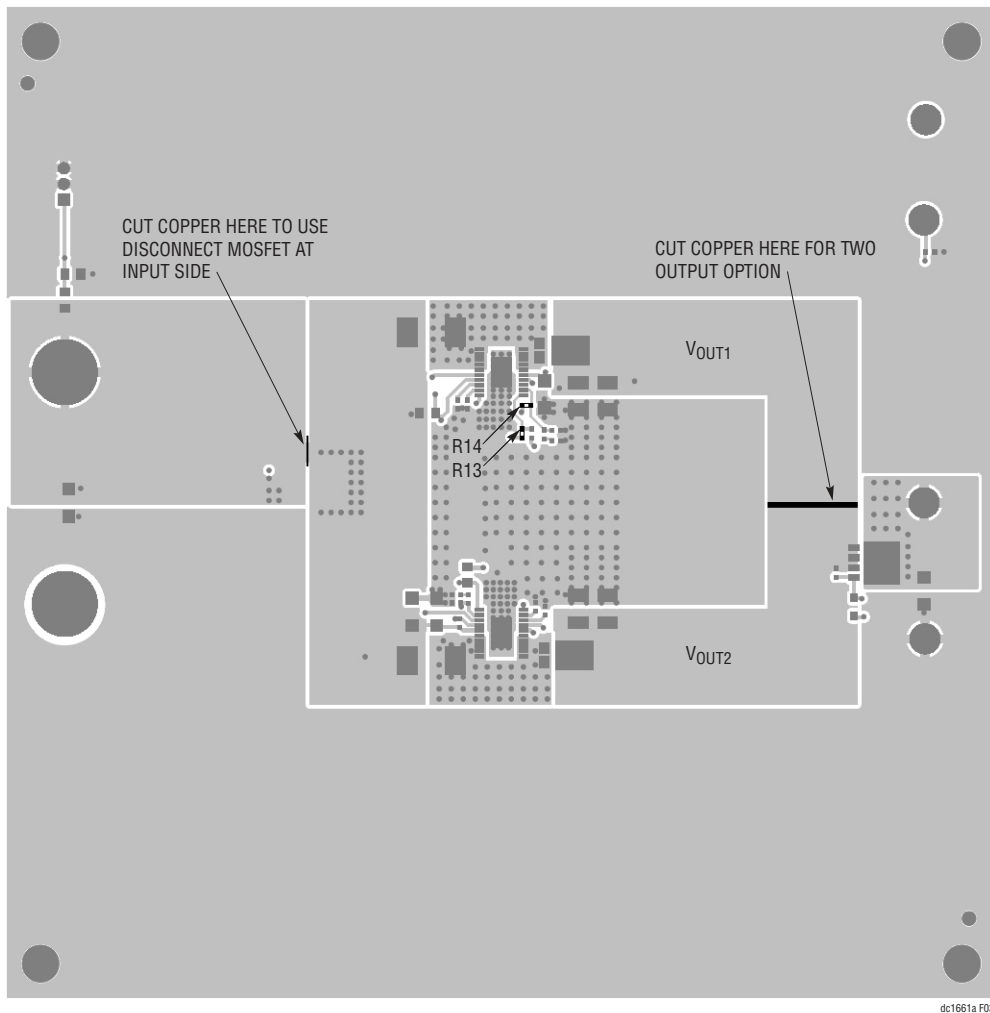

Figure 3. Using Demo Board Options

DEMO MANUAL DC1661A

PARTS LIST

ITEM	QTY	REFERENCE	PART DESCRIPTION	MANUFACTURER/PART NUMBER
Required Circuit Components For DC1424A-A				
1	5	C1, C2, C5, C11, C15	CAP, X5R, 4.7 μ F, 16V, 20% 1206	AVX, 1206YD475MAT2A
2	4	C3, C4, C9, C10	CAP, X5R, 22 μ F, 25V, 10% 1210	AVX, 12103D226KAT2A
3	1	C6	CAP, NPO, 100pF, 25V, 10% 0402	AVX, 04023A101KAT2A
4	2	C7, C12	CAP, X5R, 0.1 μ F, 25V, 10% 0402	AVX, 04023D104KAT2A
5	1	C8	CAP, X7R, 4700pF, 25V, 10% 0402	AVX, 04023C472KAT2A
6	2	D1, D2	DIODE, SCHOTTKY, POWERMITE	DIODES, MBRM560-13-F
7	2	L1, L2	INDUCTOR, 2.2 μ H 8A POWER	VISHAY, IHL P2525CZER2R2M01
8	1	Q2,	MOSFET, P-CH 20V 25A 1212-8	VISHAY, Si7141DP-T1-GE3
9	1	R1	RES, CHIP, 22.1k, 1%, 0805	VISHAY, CRCW080522K1FKEA
10	2	R3, R8	RES, CHIP, 100k, 1%, 0402	VISHAY, CRCW0402100KFKED
11	1	R4	RES, CHIP, 64.9k, 1%, 0805	VISHAY, CRCW080564K9FKEA
12	1	R5	RES, CHIP, 10k, 1%, 0402	VISHAY, CRCW040210K0FKED
13	1	R6	RES, CHIP, 10k, 1%, 0805	VISHAY, CRCW080510K0FKEA
14	2	R7, R9	RES, CHIP, 86.6k, 1%, 0402	VISHAY, CRCW040286K6FKED
15	1	R12	RES, CHIP, 6.34k, 1%, 0402	VISHAY, CRCW04026K34FKED
16	1	U1	IC, LT3579EFE-1, 20 pin TSSOP-4.4mm	LINEAR TECHNOLOGY, LT3579EFE-1#PBF
17	1	U2	IC, LT3579EFE, 20 pin TSSOP-4.4mm	LINEAR TECHNOLOGY, LT3579EFE#PBF
18	1		FAB, PRINTED CIRCUIT BOARD	DEMO CIRCUIT 1661A
Additional Demo Board Circuit Components				
1	2	R13, R14	RES, CHIP, 0 Ω , 0402	VISHAY, CRCW04020000Z0ED
Hardware For Demo Board Only				
1	4	E1 to E4	TESTPOINT, TURRET, 0.91"	MILL-MAX, 2501-2-00-80-00-00-07-0
2	2	J1, J2	BANANA JACK	KEYSTONE, 575-4
3	1	JP1	HEADER, 0.079 SINGLE ROW 3 PIN	SAMTEC, TMM-103-02-L-S
4	1	XJP	SHUNT, MTGS AT 4	SAMTEC, 2SN-BK-G
5	4	CORNERS	STAND-OFF, NYLON 0.5" TALL	KEYSTONE, 8833(SNAP ON)

SCHEMATIC DIAGRAM

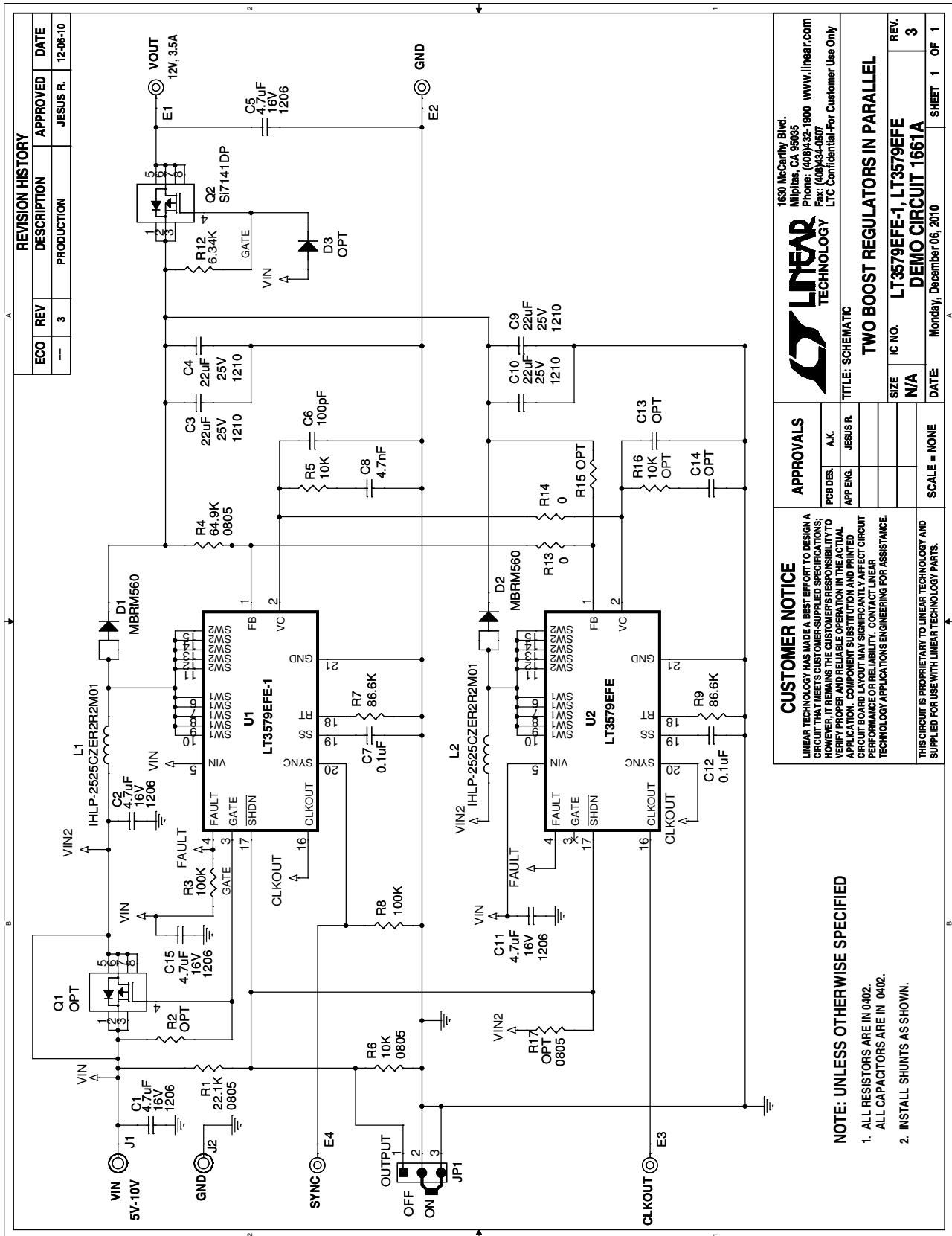

REVISION HISTORY		
ECO	REV	DESCRIPTION
---	3	PRODUCTION

APPROVED	DATE
JESUS R.	12-06-10

1600 McCarthy Blvd.
Milpitas, CA 95035
Phone: (408)424-1900 www.linear.com
Fax: (408)434-0507
LTC Confidential-For-Customer Use Only

LINEAR TECHNOLOGY

TITLE: SCHEMATIC
TWO BOOST REGULATORS IN PARALLEL

IC NO.	LT3579EFE-1, LT3579EFE	REV.	3
SIZE	N/A	DATE:	Monday, December 06, 2010
DATE:	Monday, December 06, 2010	SHEET	1 OF 1

APPROVALS	
PCB DES.	A.K.
APP ENG.	JESUS R.
SCALE	NONE

CUSTOMER NOTICE
LINEAR TECHNOLOGY HAS MADE A BEST EFFORT TO DESIGN A CIRCUIT THAT MEETS CUSTOMER-SPECIFIED REQUIREMENTS. CUSTOMERS ARE RESPONSIBLE FOR VERIFYING THE ACTUAL PERFORMANCE OF THE CIRCUIT UNDER REAL-WORLD OPERATING CONDITIONS. COMPONENT SUBSTITUTION AND PRINTED CIRCUIT BOARD LAYOUT MAY SIGNIFICANTLY AFFECT CIRCUIT PERFORMANCE OR RELIABILITY. CONTACT LINEAR TECHNOLOGY APPLICATIONS ENGINEERING FOR ASSISTANCE.

THIS CIRCUIT IS PROPRIETARY TO LINEAR TECHNOLOGY AND SUPPLIED FOR USE WITH LINEAR TECHNOLOGY PARTS.

NOTE: UNLESS OTHERWISE SPECIFIED

- ALL RESISTORS ARE IN 0402.
- ALL CAPACITORS ARE IN 0402.
- INSTALL SHUNTS AS SHOWN.



Information furnished by Linear Technology Corporation is believed to be accurate and reliable. However, no responsibility is assumed for its use. Linear Technology Corporation makes no representation that the interconnection of its circuits as described herein will not infringe on existing patent rights.

DEMO MANUAL DC1661A

DEMONSTRATION BOARD IMPORTANT NOTICE

Linear Technology Corporation (LTC) provides the enclosed product(s) under the following **AS IS** conditions:

This demonstration board (DEMO BOARD) kit being sold or provided by Linear Technology is intended for use for **ENGINEERING DEVELOPMENT OR EVALUATION PURPOSES ONLY** and is not provided by LTC for commercial use. As such, the DEMO BOARD herein may not be complete in terms of required design-, marketing-, and/or manufacturing-related protective considerations, including but not limited to product safety measures typically found in finished commercial goods. As a prototype, this product does not fall within the scope of the European Union directive on electromagnetic compatibility and therefore may or may not meet the technical requirements of the directive, or other regulations.

If this evaluation kit does not meet the specifications recited in the DEMO BOARD manual the kit may be returned within 30 days from the date of delivery for a full refund. **THE FOREGOING WARRANTY IS THE EXCLUSIVE WARRANTY MADE BY THE SELLER TO BUYER AND IS IN LIEU OF ALL OTHER WARRANTIES, EXPRESSED, IMPLIED, OR STATUTORY, INCLUDING ANY WARRANTY OF MERCHANTABILITY OR FITNESS FOR ANY PARTICULAR PURPOSE. EXCEPT TO THE EXTENT OF THIS INDEMNITY, NEITHER PARTY SHALL BE LIABLE TO THE OTHER FOR ANY INDIRECT, SPECIAL, INCIDENTAL, OR CONSEQUENTIAL DAMAGES.**

The user assumes all responsibility and liability for proper and safe handling of the goods. Further, the user releases LTC from all claims arising from the handling or use of the goods. Due to the open construction of the product, it is the user's responsibility to take any and all appropriate precautions with regard to electrostatic discharge. Also be aware that the products herein may not be regulatory compliant or agency certified (FCC, UL, CE, etc.).

No License is granted under any patent right or other intellectual property whatsoever. **LTC assumes no liability for applications assistance, customer product design, software performance, or infringement of patents or any other intellectual property rights of any kind.**

LTC currently services a variety of customers for products around the world, and therefore this transaction **is not exclusive**.

Please read the DEMO BOARD manual prior to handling the product. Persons handling this product must have electronics training and observe good laboratory practice standards. **Common sense is encouraged.**

This notice contains important safety information about temperatures and voltages. For further safety concerns, please contact a LTC application engineer.

Mailing Address:

Linear Technology
1630 McCarthy Blvd.
Milpitas, CA 95035

Copyright © 2004, Linear Technology Corporation