

PART NO.	LENGTH ± .25 [6.4]	VSWR $\triangle 07$	IL dB MAX DC-18GHz
TM40-0153-00	6.30 [160.0]		1.3
TM40-0153-01	3.00 [76.2]	DC-15GHz: RL ≤ -20dB 15-18GHz: RL ≤ -14dB (UNGATED)	1.0
TM40-0153-02	9.06 [230.0]		1.5
TM40-0153-03	10.00 [254.0]		1.6

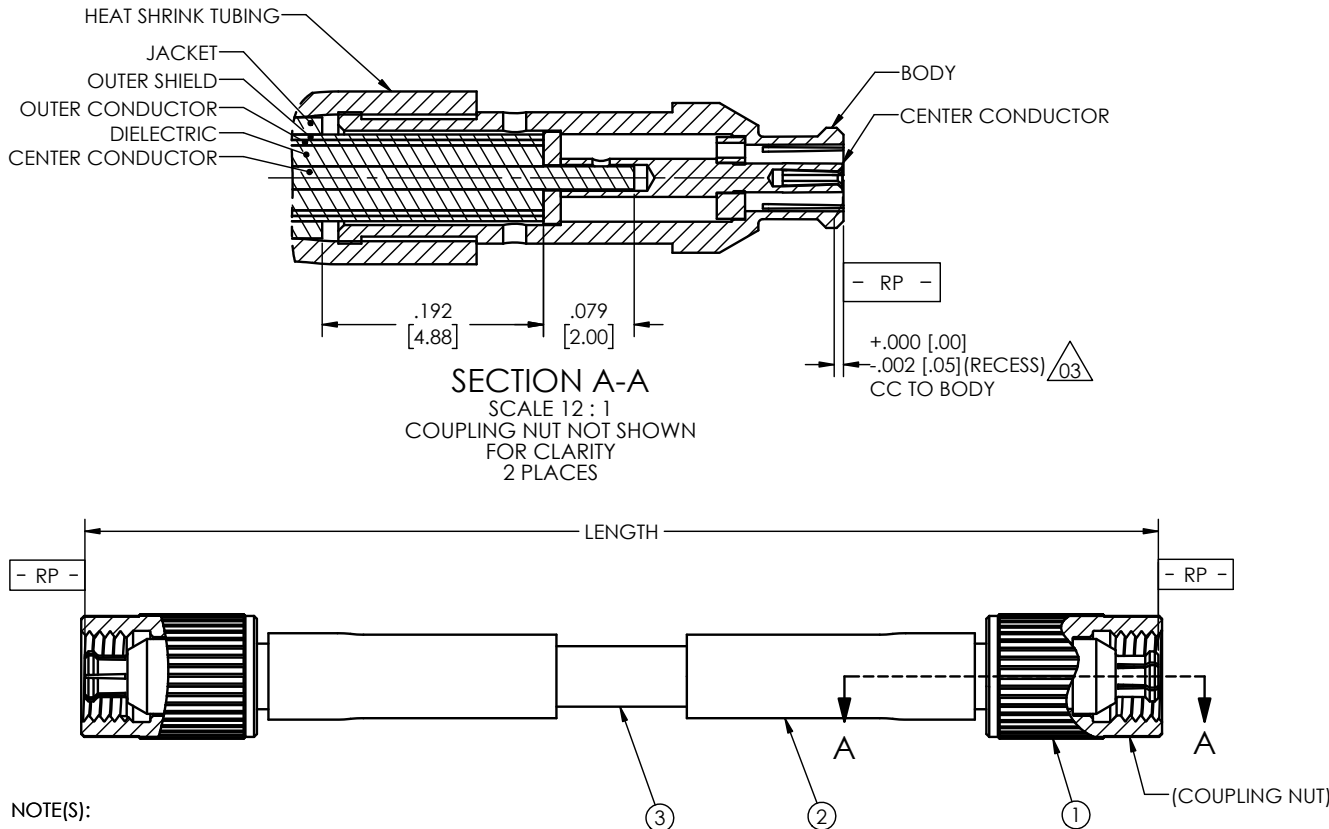

REVISIONS			
REV.	DESCRIPTION	DATE	BY
03	CORRECTED TOLERANCE	5/2/2019	PV
04	CLARIFY BOM, TITLE AND NOTE 4 THAT DWG SPECIFIES BUILD OF 2 CABLE ASSY'S	5/6/2019	PV
05	CABE CHGD TO 16507086-04 FROM 2205241J86 (ETA 105E)	5/23/2019	PV
06	ADDED GN 5; RENUMBERED INSTL NOTE 5 TO 6	6/12/2019	PV
07	ADDED PERFORMANCE REQ'T	7/30/2019	PV

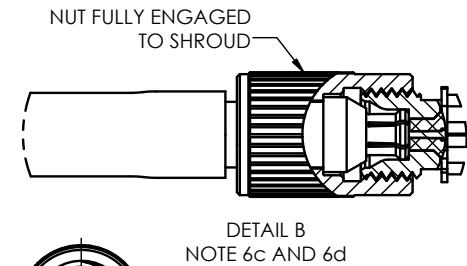
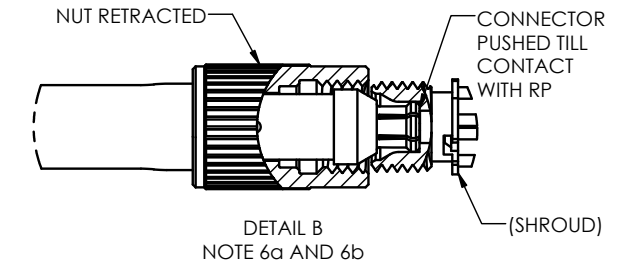

- NOTE(S):
GENERAL:
- SSMP INTERFACE DIMENSIONS PER WS132, EXCEPT DIMENSION NOTED.
 - SOLDER PER IPC-STD-001 USING LEAD-FREE SOLDER.
 - CABLE ASSY'S ARE TO BE BUILT IN PAIRS, 2 PS PHASE MATCHED.
 - MATCHED CABLE PAIRS ARE TO BE FABRICATED, PACKAGED AND SUPPLIED TOGETHER. $\triangle 04$
 - THIS CABLE ASSEMBLY WILL USE STRANDED CENTER CONDUCTOR AND BLACK FLEXIBLE PVC JACKET. $\triangle 06$

INSTALLATION (SEE DETAIL B):

- ENGAGE CONNECTOR TO SHROUD AS FOLLOWS:
 - RETRACT COUPLING NUT FROM CONNECTOR END
 - HANDLING CABLE FROM SHRINK TUBING, PUSH CONNECTOR TILL RESISTANCE IS FELT (FULLY BOTTOMS OUT).
 - ENGAGE NUT TO SHROUD.
 - ROTATE NUT UNTIL FINGER TIGHT.

RF PERFORMANCE:

- SEE TABULATION BLOCK
(NOTE: FORWARD NON-CONFORMING TEST DATA FOR ENGINEERING REVIEW.) $\triangle 07$

AR	AR	AR	AR	16507086-04	078 CABLE, STRANDED	3
4	4	4	4	M23053/4-101-0	TUBING, HEAT SHRINK, 1/8, BLK, ADHSV	2
4	4	4	4	TM14-0085-00	CONN, SSMP, FEMALE, STRAIGHT, TL	1
-03	-02	-01	-00	PART NUMBER	DESCRIPTION	ITEM NO.

DIMENSIONS ARE IN INCHES/[MILLIMETERS] ± TOLERANCES UNLESS OTHERWISE NOTED				THIRD ANGLE PROJECTION		CARLISLE	
.XXX	.XXXX	ANGLE	FRACTIONS	TITLE		SSMP TL TO SSMP TL ON COAXIAL CABLE, 2PS PHASE MATCH, QTY 2 CABLES	
0.005 [.13]	0.0005	0.5		P VOLKOV 4/3/19		REV B 7M294 TM40-0153-0X 07	
NEXT ASSY.				USED ON		SCALE: 6:1	
APPLICATION				FIG. 2		DD NOT SCALE DRAWING 1 OF 1	

THE INFORMATION CONTAINED HEREIN IS PROPRIETARY TO CARLISLE, INC. AND SHALL IN NO WAY BE REPRODUCED OR DISCLOSED IN WHOLE OR IN PART OR USED FOR ANY DESIGN OR MANUFACTURE EXCEPT WHEN SUCH USER POSSESSES DIRECT, WRITTEN AUTHORIZATION FROM CARLISLE, INC.

