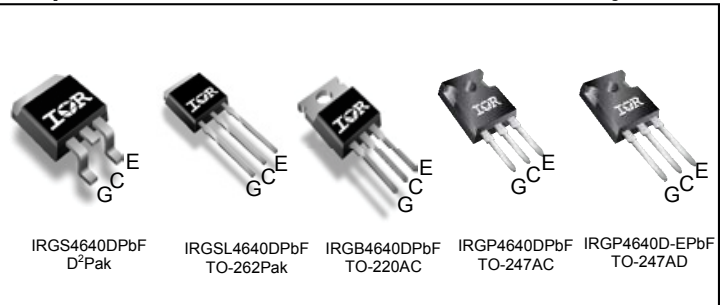
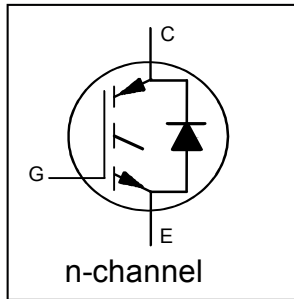


**Insulated Gate Bipolar Transistor with Ultrafast Soft Recovery Diode**

$V_{CES} = 600V$   
 $I_C = 40A, T_C = 100^\circ C$   
 $t_{SC} \geq 5\mu s, T_{J(max)} = 175^\circ C$   
 $V_{CE(ON)} \text{ typ.} = 1.60V @ I_C = 24A$



**Applications**

- Industrial Motor Drive
- Inverters
- UPS
- Welding

G	C	E
Gate	Collector	Emitter

Features	Benefits
Low $V_{CE(ON)}$ and switching losses	High efficiency in a wide range of applications and switching
Square RBSOA and maximum junction temperature 175°C	Improved reliability due to rugged hard switching performance and high power capability
Positive $V_{CE(ON)}$ temperature coefficient	Excellent current sharing in parallel operation
5µs Short Circuit SOA	Enables short circuit protection scheme
Lead-Free, RoHS Compliant	Environmentally friendly

Base part number	Package Type	Standard Pack		Orderable Part Number
		Form	Quantity	
IRGS4640DPbF	D²Pak	Tube	50	IRGS4640DPbF
		Tape and Reel Right	800	IRGS4640DTRRPbF
		Tape and Reel Left	800	IRGS4640DTRLpbF
IRGSL4640DPbF	TO-262	Tube	50	IRGSL4640DPbF
IRGB4640DPbF	TO-220AB	Tube	50	IRGB4640DPbF
IRGP4640DPbF	TO-247AC	Tube	25	IRGP4640DPbF
IRGP4640D-EPbF	TO-247AD	Tube	25	IRGP4640D-EPbF

**Absolute Maximum Ratings**

	Parameter	Max.	Units
$V_{CES}$	Collector-to-Emitter Voltage	600	V
$I_C @ T_C = 25^\circ C$	Continuous Collector Current	65	A
$I_C @ T_C = 100^\circ C$	Continuous Collector Current	40	
$I_{CM}$	Pulse Collector Current, $V_{GE} = 15V$	72	
$I_{LM}$	Clamped Inductive Load Current, $V_{GE} = 20V$ ①	96	
$I_F @ T_C = 25^\circ C$	Diode Continuous Forward Current	65	
$I_F @ T_C = 100^\circ C$	Diode Continuous Forward Current	40	
$I_{FM}$	Diode Maximum Forward Current ④	96	V
$V_{GE}$	Continuous Gate-to-Emitter Voltage	±20	
	Transient Gate to Emitter Voltage	±30	
$P_D @ T_C = 25^\circ C$	Maximum Power Dissipation	250	W
$P_D @ T_C = 100^\circ C$	Maximum Power Dissipation	125	
$T_J$ $T_{STG}$	Operating Junction and Storage Temperature Range	-55 to +175	C
	Soldering Temperature, for 10 sec. (1.6mm from case)	300	
	Mounting Torque, 6-32 or M3 Screw (TO-220, TO-247)	10 lbf·in (1.1 N·m)	

Notes ① through ⑥ are on page 8

**Thermal Resistance**

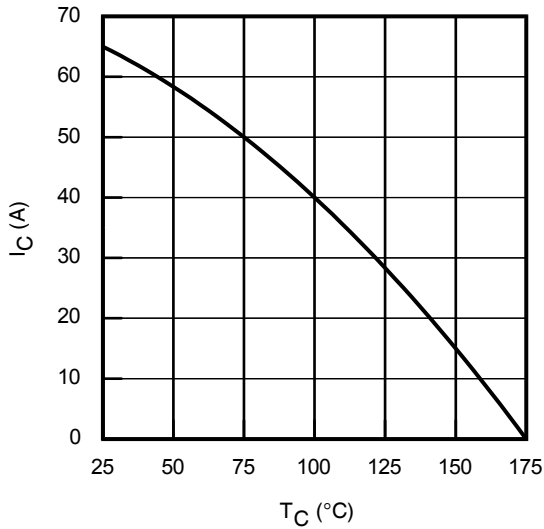
	Parameter	Min.	Typ.	Max.	Units
R <sub>θJC</sub> (IGBT)	Thermal Resistance Junction-to-Case (D <sup>2</sup> Pak, TO-220, TO-262) ②	—	—	0.60	°C/W
	Thermal Resistance Junction-to-Case (TO-247) ②	—	—	0.60	
R <sub>θJC</sub> (Diode)	Thermal Resistance Junction-to-Case (D <sup>2</sup> Pak, TO-220, TO-262) ②	—	—	1.53	
	Thermal Resistance Junction-to-Case (TO-247) ②	—	—	1.62	
R <sub>θCS</sub>	Thermal Resistance, Case-to-Sink (flat, greased surface– TO 220, D <sup>2</sup> Pak, TO-262)	—	0.50	—	
	Thermal Resistance, Case-to-Sink (flat, greased surface– TO 247)	—	0.24	—	
R <sub>θJA</sub>	Thermal Resistance, Junction-to-Ambient (PCB Mount - D <sup>2</sup> Pak, TO-262) ⑥	—	—	40	
	Thermal Resistance, Junction-to-Ambient (Socket Mount –TO-247)	—	—	40	
	Thermal Resistance, Junction-to-Ambient (Socket Mount –TO-220)	—	—	62	

**Electrical Characteristics @ T<sub>J</sub> = 25°C (unless otherwise specified)**

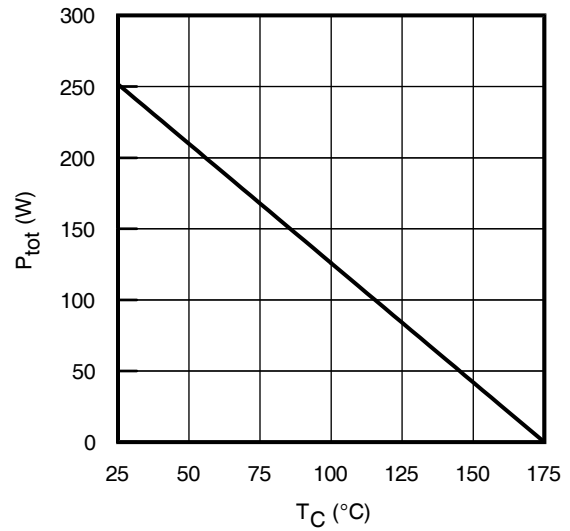
	Parameter	Min.	Typ.	Max.	Units	Conditions
V <sub>(BR)CES</sub>	Collector-to-Emitter Breakdown Voltage	600	—	—	V	V <sub>GE</sub> = 0V, I <sub>C</sub> = 100μA ③
ΔV <sub>(BR)CES/ΔT<sub>J</sub></sub>	Temperature Coeff. of Breakdown Voltage	—	0.30	—	V/°C	V <sub>GE</sub> = 0V, I <sub>C</sub> = 1mA (25°C-175°C)
V <sub>CE(on)</sub>	Collector-to-Emitter Saturation Voltage	—	1.60	1.90	V	I <sub>C</sub> = 24A, V <sub>GE</sub> = 15V, T <sub>J</sub> = 25°C
		—	1.90	—		I <sub>C</sub> = 24A, V <sub>GE</sub> = 15V, T <sub>J</sub> = 150°C
		—	2.0	—		I <sub>C</sub> = 24A, V <sub>GE</sub> = 15V, T <sub>J</sub> = 175°C
V <sub>GE(th)</sub>	Gate Threshold Voltage	4.0	—	6.5	V	V <sub>CE</sub> = V <sub>GE</sub> , I <sub>C</sub> = 700μA
ΔV <sub>GE(th)/ΔT<sub>J</sub></sub>	Threshold Voltage Temp. Coefficient	—	-18	—	mV/°C	V <sub>CE</sub> = V <sub>GE</sub> , I <sub>C</sub> = 1.0mA (25°C-175°C)
g <sub>fe</sub>	Forward Transconductance	—	17	—	S	V <sub>CE</sub> = 50V, I <sub>C</sub> = 24A, PW = 80μs
I <sub>CES</sub>	Collector-to-Emitter Leakage Current	—	2.0	25	μA	V <sub>GE</sub> = 0V, V <sub>CE</sub> = 600V
		—	775	—		V <sub>GE</sub> = 0V, V <sub>CE</sub> = 600V, T <sub>J</sub> = 175°C
I <sub>GES</sub>	Gate-to-Emitter Leakage Current	—	—	±100	nA	V <sub>GE</sub> = ±20V
V <sub>FM</sub>	Diode Forward Voltage Drop	—	1.8	2.6	V	I <sub>F</sub> = 24A
		—	1.28	—		I <sub>F</sub> = 24A, T <sub>J</sub> = 175°C

**Switching Characteristics @  $T_J = 25^\circ\text{C}$  (unless otherwise specified)**

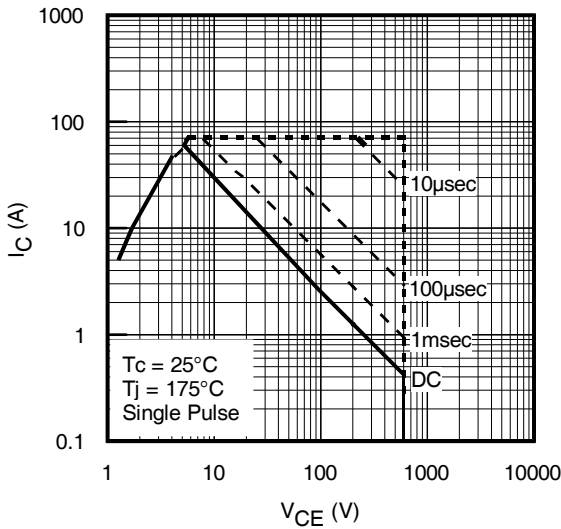
	Parameter	Min.	Typ.	Max	Units	Conditions
$Q_g$	Total Gate Charge	—	50	75	nC	$I_C = 24\text{A}$ $V_{GE} = 15\text{V}$ $V_{CC} = 400\text{V}$
$Q_{ge}$	Gate-to-Emitter Charge	—	13	20		
$Q_{gc}$	Gate-to-Collector Charge	—	21	31		
$E_{on}$	Turn-On Switching Loss	—	115	201	$\mu\text{J}$	$I_C = 24\text{A}$ , $V_{CC} = 400\text{V}$ , $V_{GE} = 15\text{V}$ $R_G = 10\Omega$ , $L = 200\mu\text{H}$ , $L_S = 150\text{nH}$ , $T_J = 25^\circ\text{C}$
$E_{off}$	Turn-Off Switching Loss	—	600	700		
$E_{total}$	Total Switching Loss	—	715	901		
$t_{d(on)}$	Turn-On delay time	—	41	53	ns	Energy losses include tail & diode reverse recovery ⑤
$t_r$	Rise time	—	22	31		
$t_{d(off)}$	Turn-Off delay time	—	104	115		
$t_f$	Fall time	—	29	41		
$E_{on}$	Turn-On Switching Loss	—	420	—	$\mu\text{J}$	$I_C = 24\text{A}$ , $V_{CC} = 400\text{V}$ , $V_{GE} = 15\text{V}$ $R_G = 10\Omega$ , $L = 200\mu\text{H}$ , $L_S = 150\text{nH}$ , $T_J = 175^\circ\text{C}$
$E_{off}$	Turn-Off Switching Loss	—	840	—		
$E_{total}$	Total Switching Loss	—	1260	—		
$t_{d(on)}$	Turn-On delay time	—	40	—	ns	Energy losses include tail & diode reverse recovery ⑤
$t_r$	Rise time	—	24	—		
$t_{d(off)}$	Turn-Off delay time	—	125	—		
$t_f$	Fall time	—	39	—		
$C_{ies}$	Input Capacitance	—	1490	—	pF	$V_{GE} = 0\text{V}$ $V_{CC} = 30\text{V}$ $f = 1.0\text{MHz}$
$C_{oes}$	Output Capacitance	—	129	—		
$C_{res}$	Reverse Transfer Capacitance	—	45	—		
RBSOA	Reverse Bias Safe Operating Area	FULL SQUARE				$T_J = 175^\circ\text{C}$ , $I_C = 96\text{A}$ $V_{CC} = 480\text{V}$ , $V_p \leq 600\text{V}$ $R_G = 10\Omega$ , $V_{GE} = +20\text{V to } 0\text{V}$
SCSOA	Short Circuit Safe Operating Area	5.0	—	—	$\mu\text{s}$	$V_{CC} = 400\text{V}$ , $V_p \leq 600\text{V}$ $R_G = 10\Omega$ , $V_{GE} = +15\text{V to } 0\text{V}$
$E_{rec}$	Reverse Recovery Energy of the Diode	—	621	—	$\mu\text{J}$	$T_J = 175^\circ\text{C}$
$t_{rr}$	Diode Reverse Recovery Time	—	89	—	ns	$V_{CC} = 400\text{V}$ , $I_F = 24\text{A}$ , $V_{GE} = 15\text{V}$ ,
$I_{rr}$	Peak Reverse Recovery Current	—	37	—	A	$R_G = 10\Omega$ , $L = 200\mu\text{H}$ , $L_S = 150\text{nH}$



**Fig. 1** - Maximum DC Collector Current vs. Case Temperature

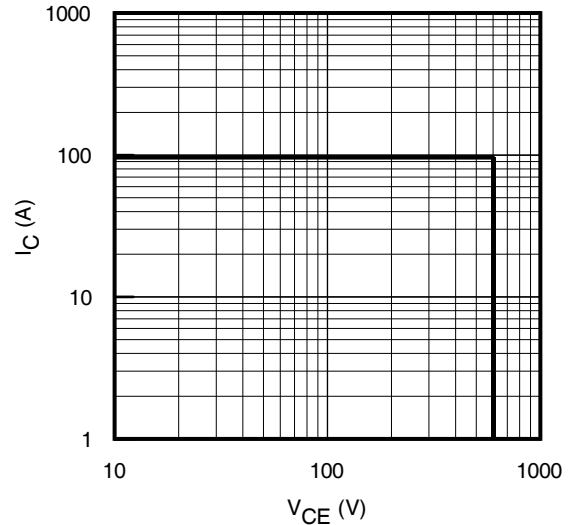


**Fig. 2** - Power Dissipation vs. Case Temperature



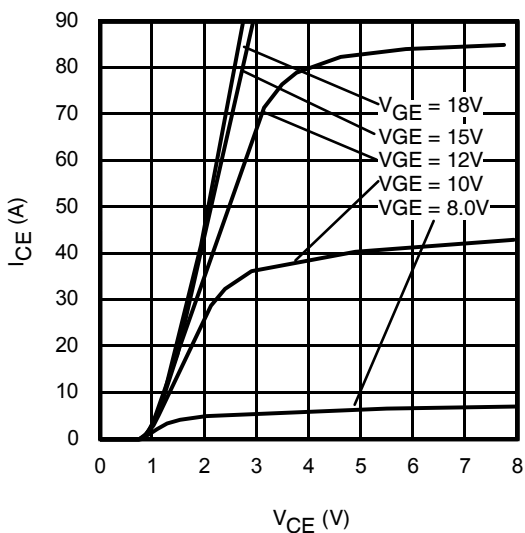
**Fig. 3** - Forward SOA

$T_C = 25^\circ\text{C}$ ;  $T_J \leq 175^\circ\text{C}$ ;  $V_{GE} = 15\text{V}$

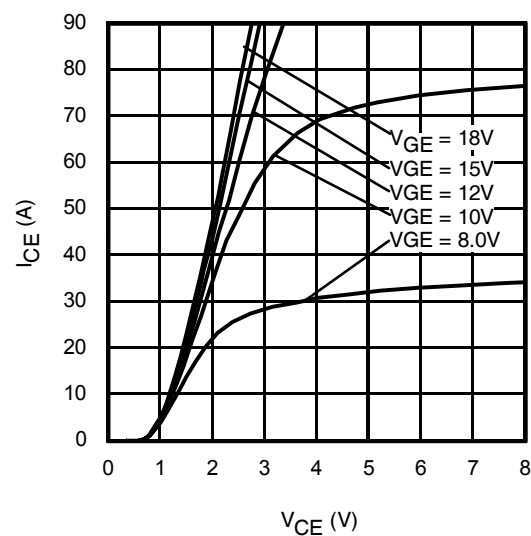


**Fig. 4** - Reverse Bias SOA

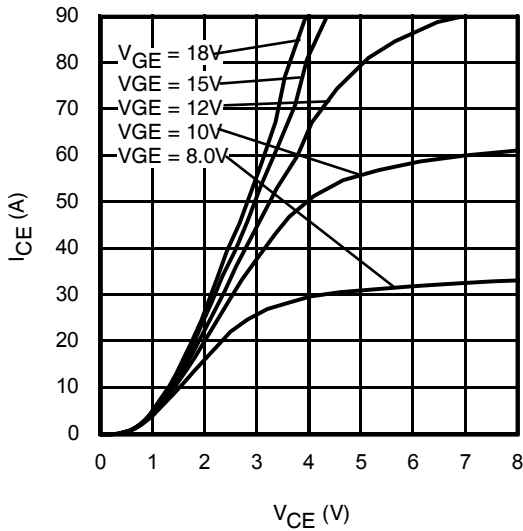
$T_J = 175^\circ\text{C}$ ;  $V_{GE} = 20\text{V}$



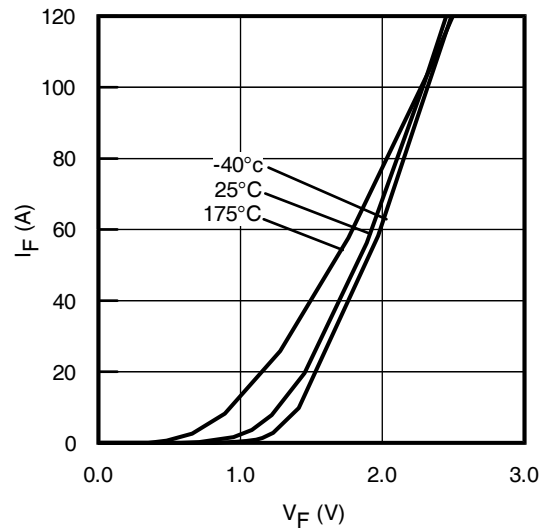
**Fig. 5** - Typ. IGBT Output Characteristics  
 $T_J = -40^\circ\text{C}$ ;  $t_p = 80\mu\text{s}$



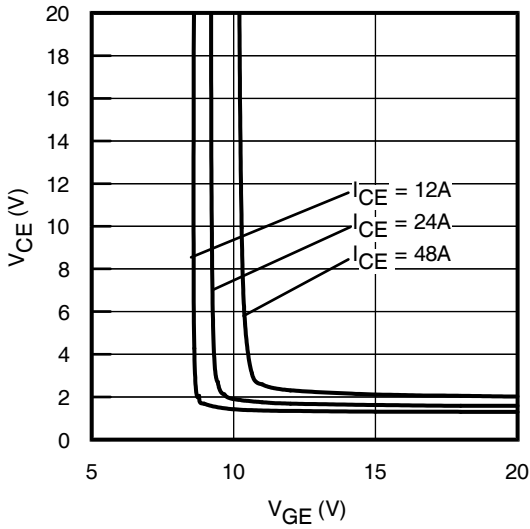
**Fig. 6** - Typ. IGBT Output Characteristics  
 $T_J = 25^\circ\text{C}$ ;  $t_p = 80\mu\text{s}$



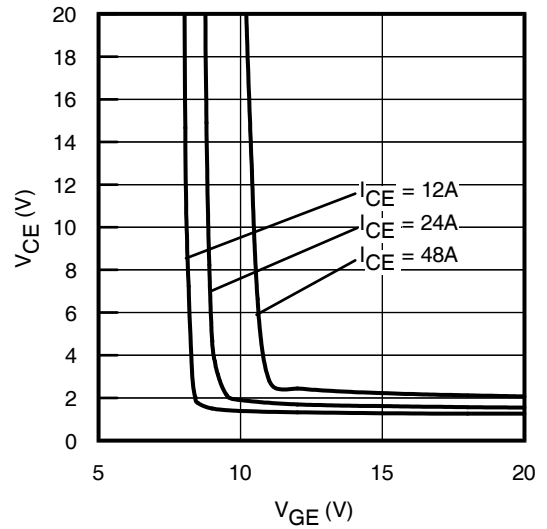
**Fig. 7 - Typ. IGBT Output Characteristics**  
 $T_J = 175^\circ\text{C}$ ;  $t_p = 80\mu\text{s}$



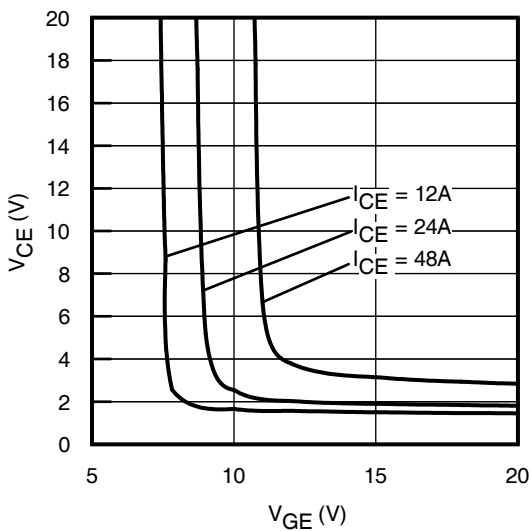
**Fig. 8 - Typ. Diode Forward Voltage Drop Characteristics**



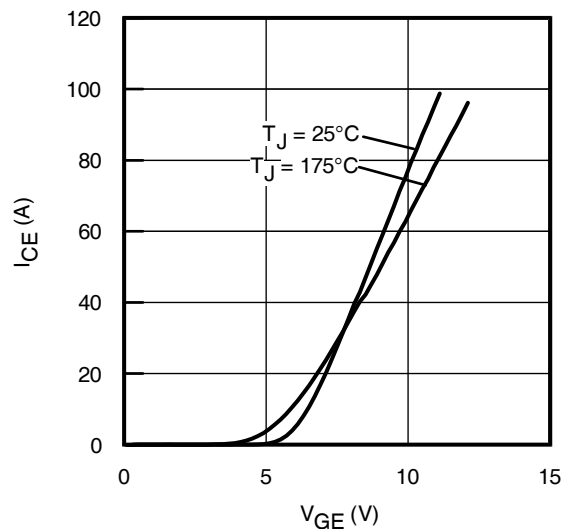
**Fig. 9 - Typical  $V_{CE}$  vs.  $V_{GE}$**   
 $T_J = -40^\circ\text{C}$



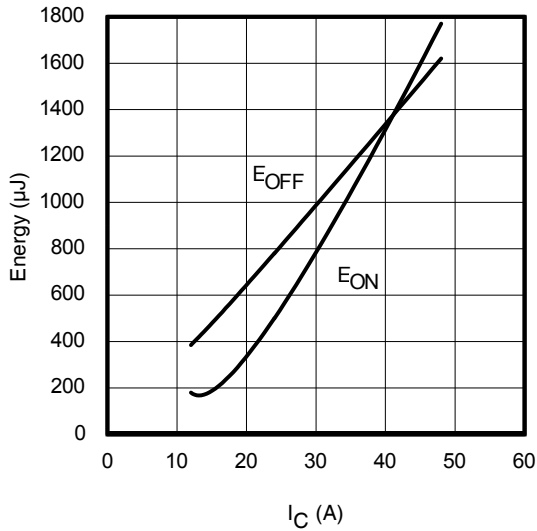
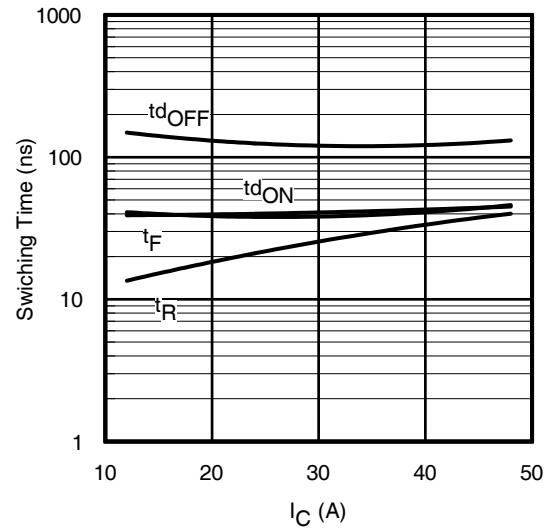
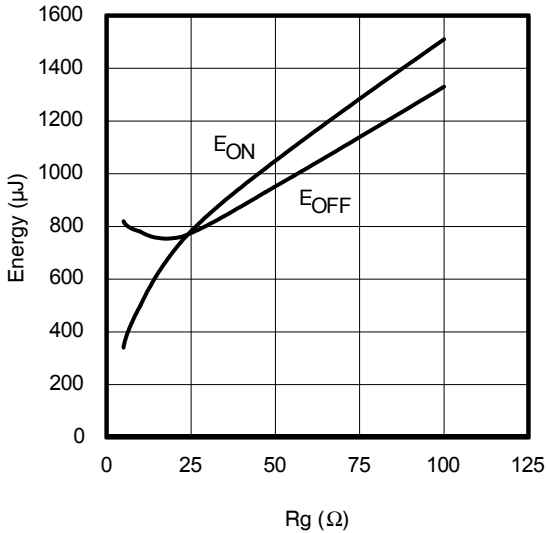
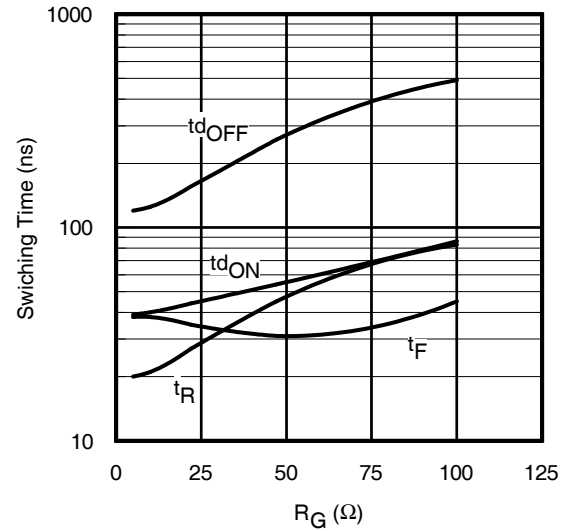
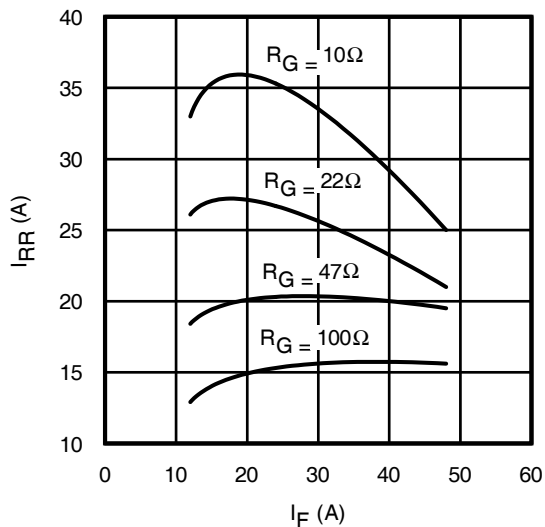
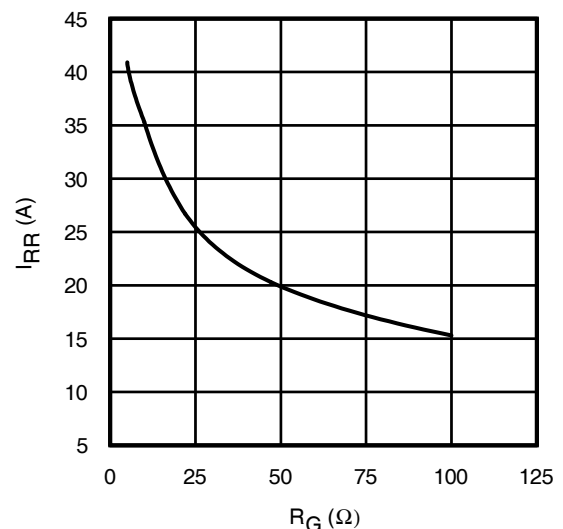
**Fig. 10 - Typical  $V_{CE}$  vs.  $V_{GE}$**   
 $T_J = 25^\circ\text{C}$

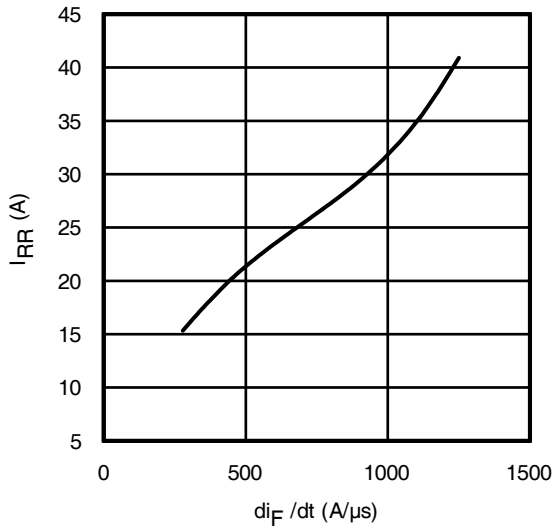


**Fig. 11 - Typical  $V_{CE}$  vs.  $V_{GE}$**   
 $T_J = 175^\circ\text{C}$

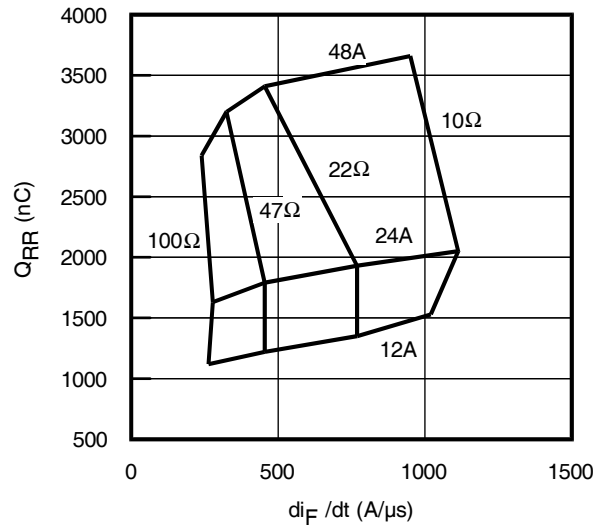


**Fig. 12 - Typ. Transfer Characteristics**  
 $V_{CE} = 50\text{V}$ ;  $t_p = 10\mu\text{s}$

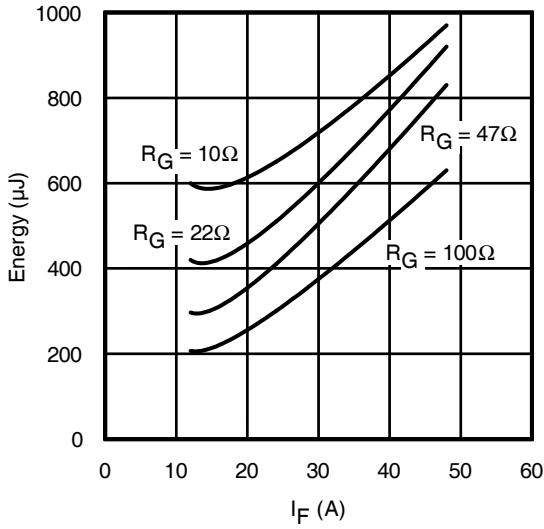

**Fig. 13** - Typ. Energy Loss vs.  $I_C$ 
 $T_J = 175^\circ\text{C}; L = 200\mu\text{H}; V_{CE} = 400\text{V}; R_G = 10\Omega; V_{GE} = 15\text{V}$ 

**Fig. 14** - Typ. Switching Time vs.  $I_C$ 
 $T_J = 175^\circ\text{C}; L = 200\mu\text{H}; V_{CE} = 400\text{V}; R_G = 10\Omega; V_{GE} = 15\text{V}$ 

**Fig. 15** - Typ. Energy Loss vs.  $R_G$ 
 $T_J = 175^\circ\text{C}; L = 200\mu\text{H}; V_{CE} = 400\text{V}; I_{CE} = 24\text{A}; V_{GE} = 15\text{V}$ 

**Fig. 16** - Typ. Switching Time vs.  $R_G$ 
 $T_J = 175^\circ\text{C}; L = 200\mu\text{H}; V_{CE} = 400\text{V}; I_{CE} = 24\text{A}; V_{GE} = 15\text{V}$ 

**Fig. 17** - Typ. Diode  $I_{RR}$  vs.  $I_F$ 
 $T_J = 175^\circ\text{C}$ 

**Fig. 18** - Typ. Diode  $I_{RR}$  vs.  $R_G$ 
 $T_J = 175^\circ\text{C}$



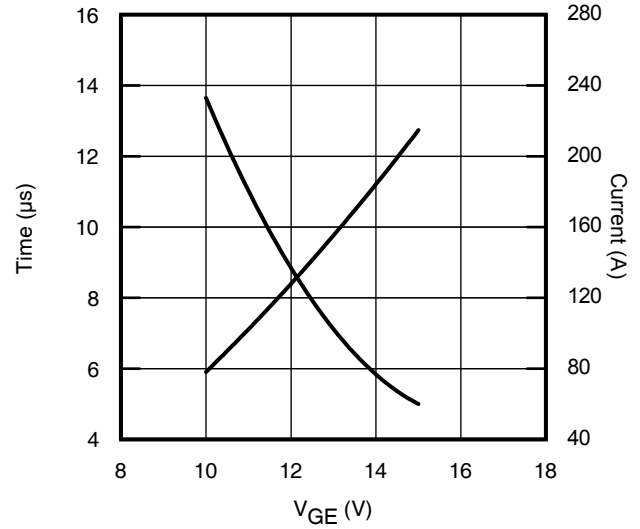
**Fig. 19** - Typ. Diode  $I_{RR}$  vs.  $di_F/dt$   
 $V_{CC} = 400V$ ;  $V_{GE} = 15V$ ;  $I_F = 24A$ ;  $T_J = 175^\circ C$



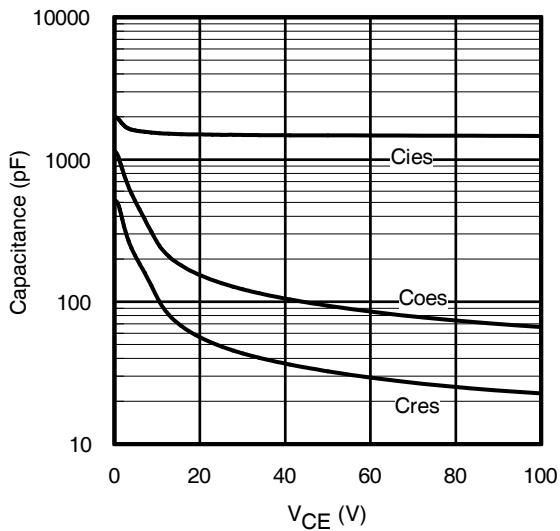
**Fig. 20** - Typ. Diode  $Q_{RR}$  vs.  $di_F/dt$   
 $V_{CC} = 400V$ ;  $V_{GE} = 15V$ ;  $T_J = 175^\circ C$



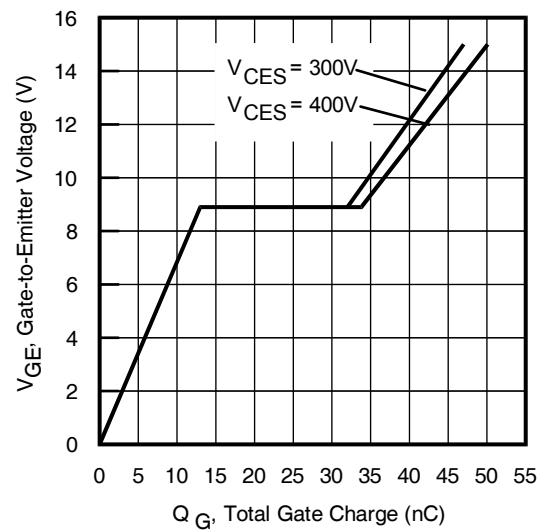
**Fig. 21** - Typ. Diode  $E_{RR}$  vs.  $I_F$   
 $T_J = 175^\circ C$



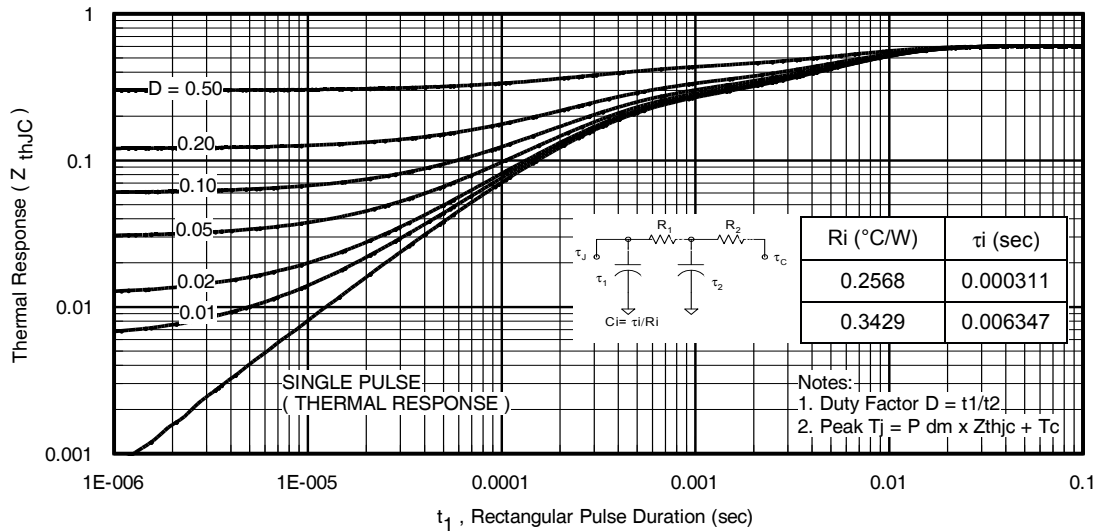
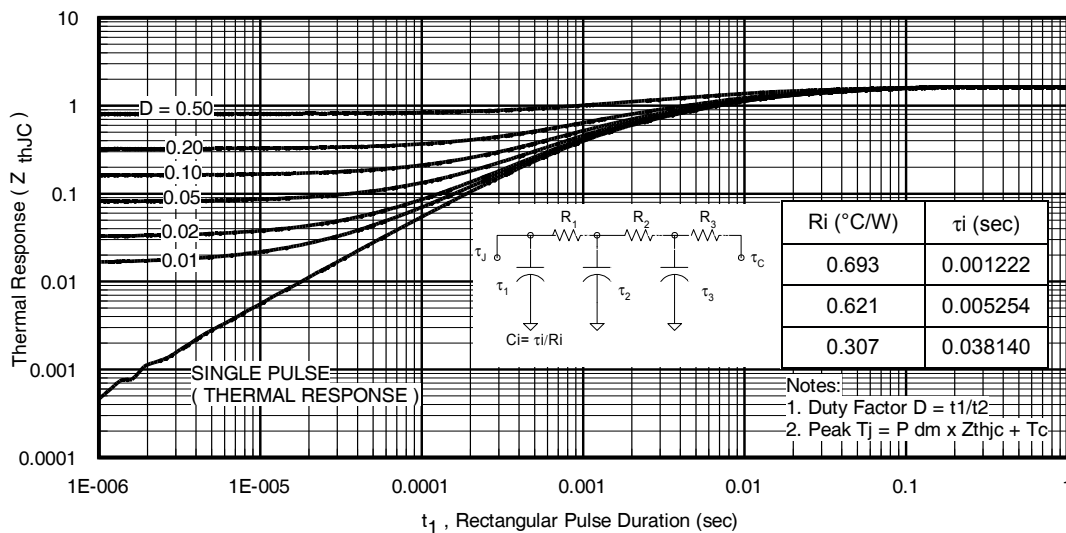
**Fig. 22** -  $V_{GE}$  vs. Short Circuit Time  
 $V_{CC} = 400V$ ;  $T_C = 25^\circ C$



**Fig. 23** - Typ. Capacitance vs.  $V_{CE}$   
 $V_{GE} = 0V$ ;  $f = 1MHz$

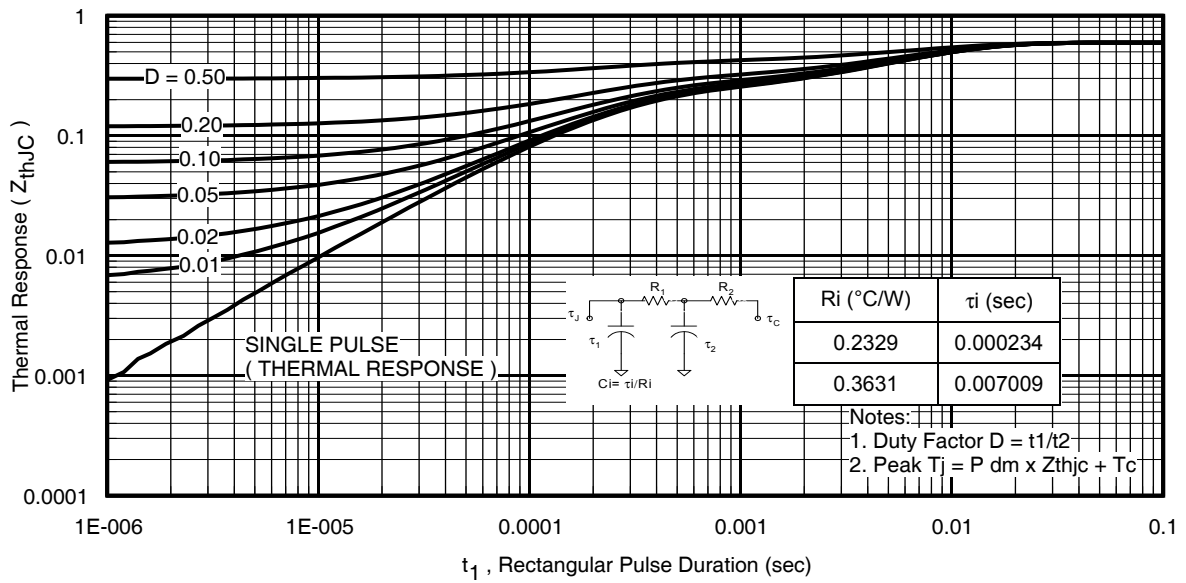
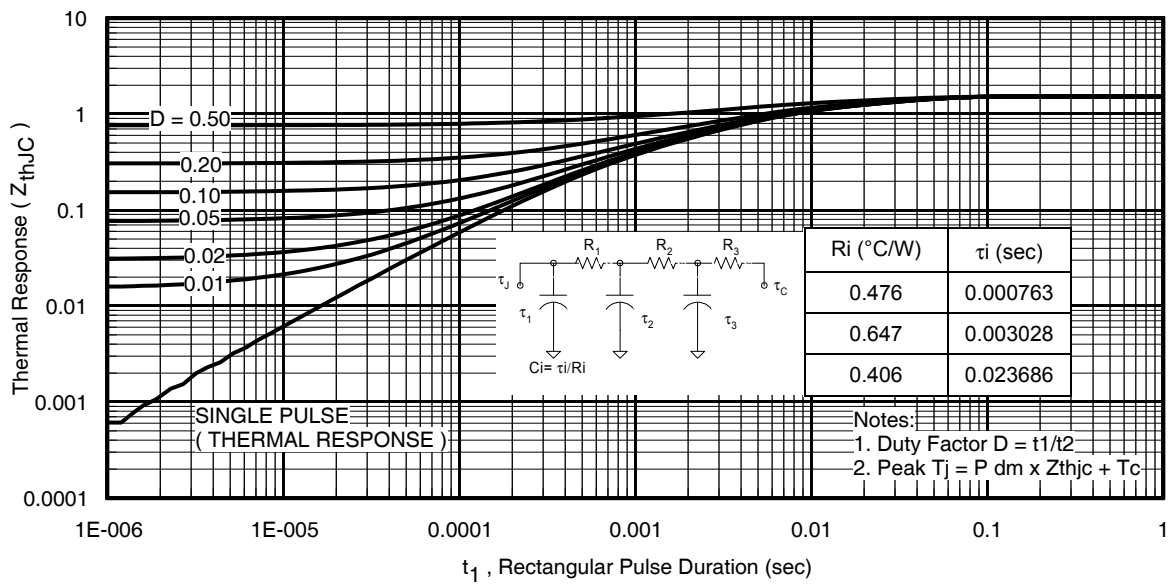


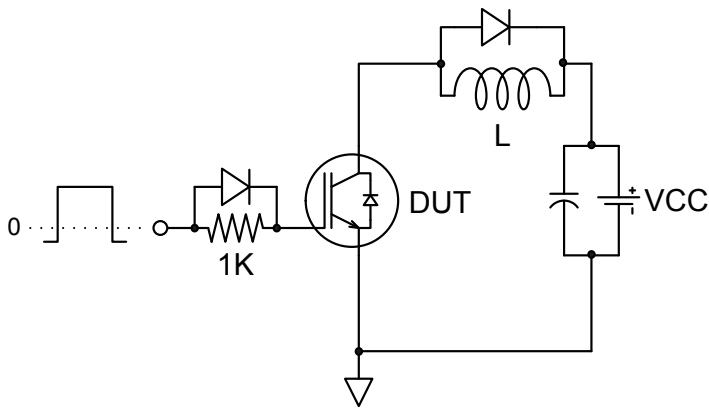
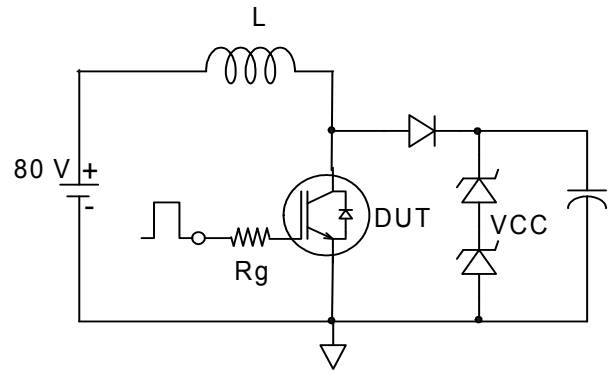
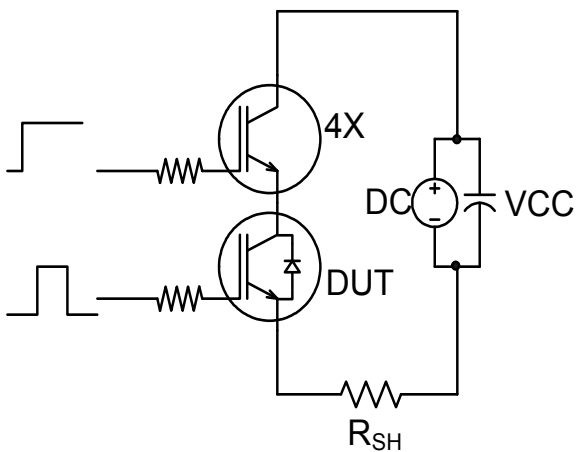
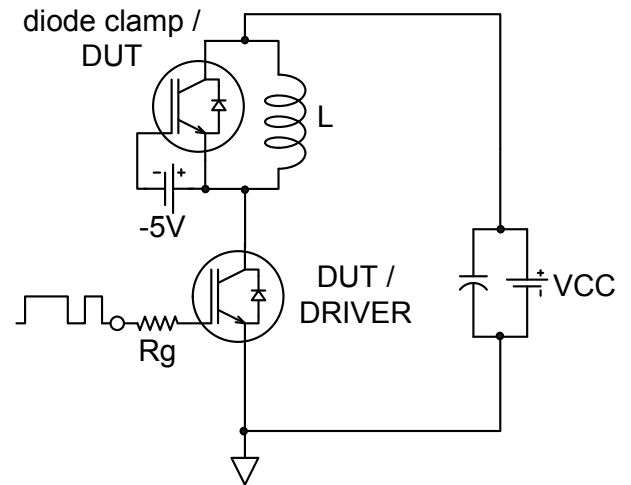
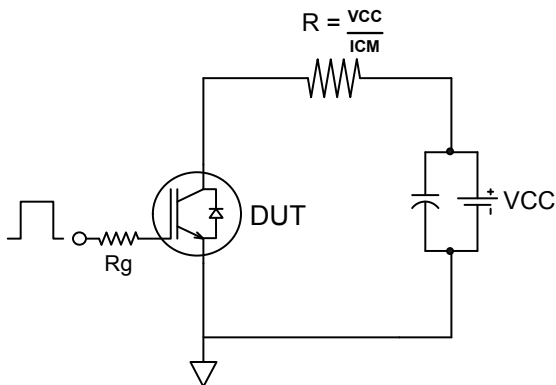
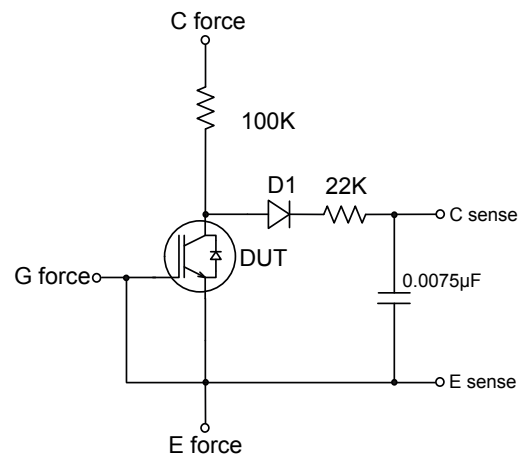
**Fig. 24** - Typical Gate Charge vs.  $V_{GE}$   
 $I_{CE} = 24A$ ;  $L = 600\mu H$

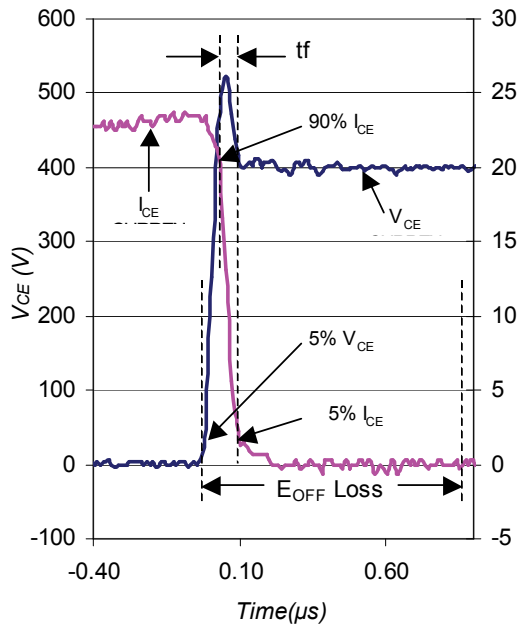

**Fig. 25 - Maximum Transient Thermal Impedance, Junction-to-Case (IGBT-TO247 Pak)**

**Fig. 26 - Maximum Transient Thermal Impedance, Junction-to-Case (DIODE- TO-247 Pak)**
**Notes:**

- ①  $V_{CC} = 80\% (V_{CES}), V_{GE} = 20V, L = 100\mu H, R_G = 10\Omega$ .
- ②  $R_{\theta}$  is measured at  $T_J$  of approximately  $90^\circ C$ .
- ③ Refer to AN-1086 for guidelines for measuring  $V_{(BR)CES}$  safely.
- ④ Pulse width limited by maximum junction temperature.
- ⑤ Values influenced by parasitic L and C in measurement.
- ⑥ When mounted on 1" square PCB (FR-4 or G-10 Material). For recommended footprint and soldering techniques refer to application note #AN-994. <http://www.irf.com/technical-info/appnotes/an-994.pdf>

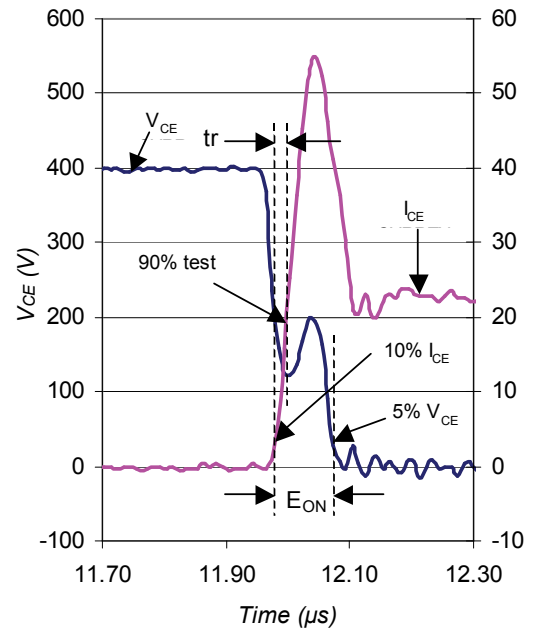



**Fig. 27 - Maximum Transient Thermal Impedance, Junction-to-Case (IGBT-TO-220Pak)**

**Fig. 28 - Maximum Transient Thermal Impedance, Junction-to-Case (DIODE-TO-220Pak)**

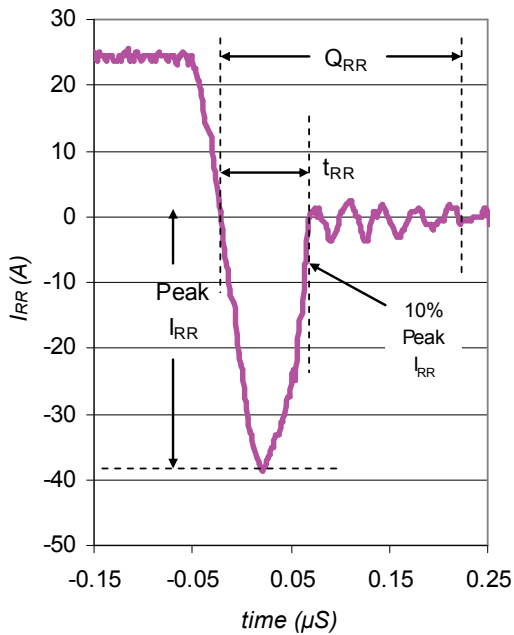

**Fig.C.T.1 - Gate Charge Circuit (turn-off)**

**Fig.C.T.2 - RBSOA Circuit**

**Fig.C.T.3 - S.C. SOA Circuit**

**Fig.C.T.4 - Switching Loss Circuit**

**Fig.C.T.5 - Resistive Load Circuit**

**Fig.C.T.6 - BVCES Filter Circuit**



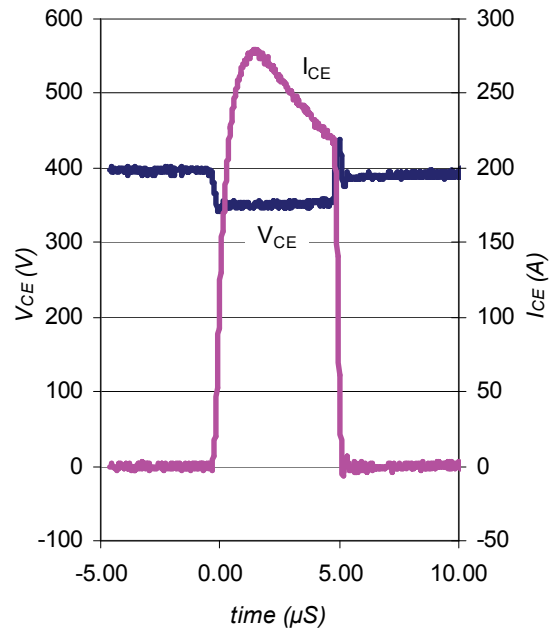
**Fig. WF1** - Typ. Turn-off Loss Waveform  
@ T<sub>J</sub> = 175°C using Fig. CT.4



**Fig. WF2** - Typ. Turn-on Loss Waveform  
@ T<sub>J</sub> = 175°C using Fig. CT.4



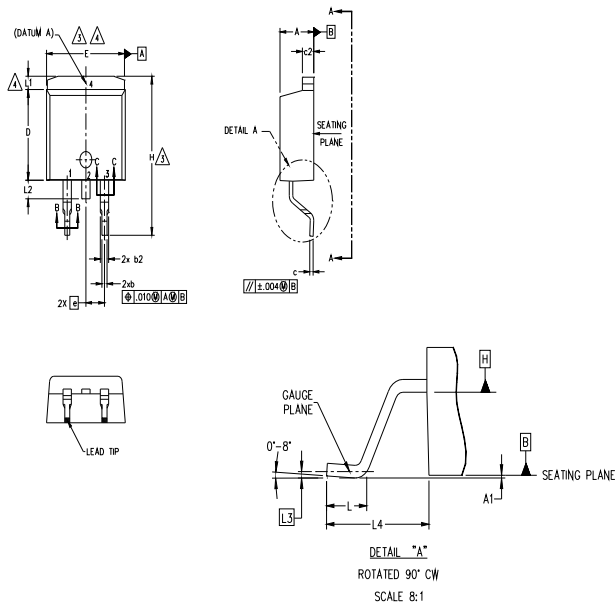
**Fig. WF3** - Typ. Diode Recovery Waveform  
@ T<sub>J</sub> = 175°C using Fig. CT.4



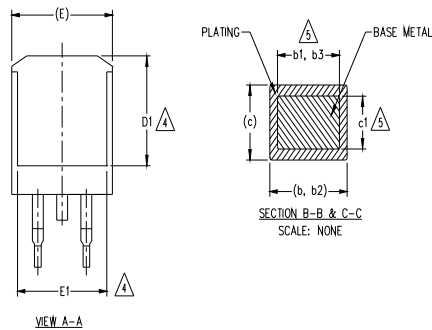
**Fig. WF4** - Typ. S.C. Waveform  
@ T<sub>J</sub> = 150°C using Fig. CT.3

# D<sup>2</sup>-PAK (TO-263AB) Package Outline

Dimensions are shown in millimeters (inches)



SYMBOL	DIMENSIONS				NOTES
	MILLIMETERS		INCHES		
	MIN.	MAX.	MIN.	MAX.	
A	4.06	4.83	.160	.190	
A1	0.00	0.254	.000	.010	
b	0.51	0.99	.020	.039	
b1	0.51	0.89	.020	.035	5
b2	1.14	1.78	.045	.070	
b3	1.14	1.73	.045	.068	5
c	0.38	0.74	.015	.029	
c1	0.38	0.58	.015	.023	5
c2	1.14	1.65	.045	.065	
D	8.38	9.65	.330	.380	3
D1	6.86	-	.270	-	4
E	9.65	10.67	.380	.420	3,4
E1	6.22	-	.245	-	4
e	2.54 BSC		.100 BSC		
H	14.61	15.88	.575	.625	
L	1.78	2.79	.070	.110	
L1	-	1.65	-	.066	4
L2	-	1.78	-	.070	
L3	0.25 BSC		.010 BSC		
L4	4.78	5.28	.188	.208	

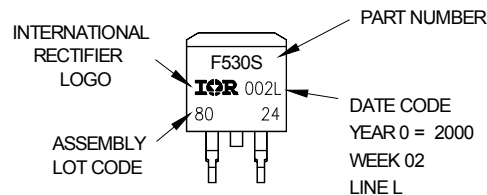


- NOTES:
1. DIMENSIONING AND TOLERANCING PER ASME Y14.5M-1994
  2. DIMENSIONS ARE SHOWN IN MILLIMETERS [INCHES].
  3. DIMENSION D & E DO NOT INCLUDE MOLD FLASH. MOLD FLASH SHALL NOT EXCEED 0.127 [0.005"] PER SIDE. THESE DIMENSIONS ARE MEASURED AT THE OUTMOST EXTREMES OF THE PLASTIC BODY AT DATUM H.
  4. THERMAL PAD CONTOUR OPTIONAL WITHIN DIMENSION E, L1, D1 & E1.
  5. DIMENSION b1 AND c1 APPLY TO BASE METAL ONLY.
  6. DATUM A & B TO BE DETERMINED AT DATUM PLANE H.
  7. CONTROLLING DIMENSION: INCH.
  8. OUTLINE CONFORMS TO JEDEC OUTLINE TO-263AB.

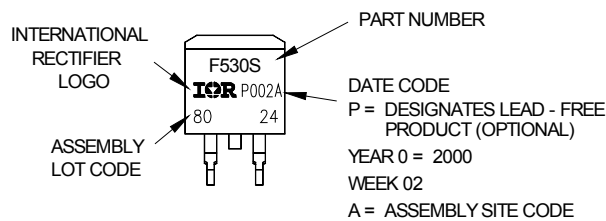
# D<sup>2</sup>-Pak (TO-263AB) Part Marking Information

EXAMPLE: THIS IS AN IRF530S WITH  
LOT CODE 8024  
ASSEMBLED ON VVV 02, 2000  
IN THE ASSEMBLY LINE "L"

Note: "P" in assembly line position  
indicates "Lead - Free"



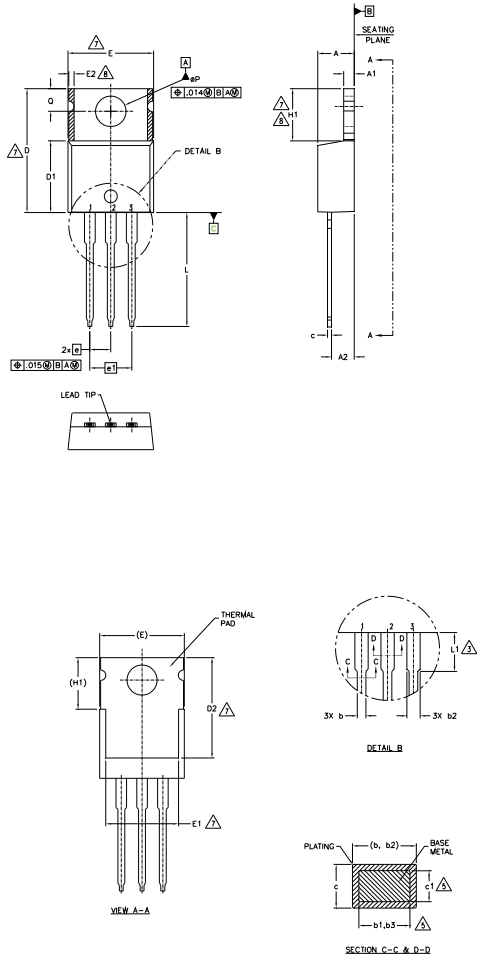
OR



Note: For the most current drawing please refer to IR website at <http://www.irf.com/package/>

# TO-220AB Package Outline

(Dimensions are shown in millimeters (inches))



**NOTES:**

- 1.- DIMENSIONING AND TOLERANCING AS PER ASME Y14.5 M- 1994.
- 2.- DIMENSIONS ARE SHOWN IN INCHES [MILLIMETERS].
- 3.- LEAD DIMENSION AND FINISH UNCONTROLLED IN L1.
- 4.- DIMENSION D, D1 & E DO NOT INCLUDE MOLD FLASH. MOLD FLASH SHALL NOT EXCEED .005" (0.127) PER SIDE. THESE DIMENSIONS ARE MEASURED AT THE OUTERMOST EXTREMES OF THE PLASTIC BODY.
- 5.- DIMENSION b1, b3 & c1 APPLY TO BASE METAL ONLY.
- 6.- CONTROLLING DIMENSION : INCHES.
- 7.- THERMAL PAD CONTOUR OPTIONAL WITHIN DIMENSIONS E,H1,D2 & E1
- 8.- DIMENSION E2 X H1 DEFINE A ZONE WHERE STAMPING AND SINGULATION IRREGULARITIES ARE ALLOWED.
- 9.- OUTLINE CONFORMS TO JEDEC TO-220, EXCEPT A2 (max.) AND D2 (min.) WHERE DIMENSIONS ARE DERIVED FROM THE ACTUAL PACKAGE OUTLINE.

SYMBOL	DIMENSIONS				NOTES
	MILLIMETERS		INCHES		
	MIN.	MAX.	MIN.	MAX.	
A	3.56	4.83	.140	.190	
A1	1.14	1.40	.045	.055	
A2	2.03	2.92	.080	.115	
b	0.38	1.01	.015	.040	
b1	0.38	0.97	.015	.038	5
b2	1.14	1.78	.045	.070	
b3	1.14	1.73	.045	.068	5
c	0.36	0.61	.014	.024	
c1	0.36	0.56	.014	.022	5
D	14.22	16.51	.560	.650	4
D1	8.38	9.02	.330	.355	
D2	11.68	12.88	.460	.507	7
E	9.65	10.67	.380	.420	4,7
E1	6.86	8.89	.270	.350	7
E2	-	0.76	-	.030	8
e	2.54 BSC		.100 BSC		
e1	5.08 BSC		.200 BSC		
H1	5.84	6.86	.230	.270	7,8
L	12.70	14.73	.500	.580	
L1	3.56	4.06	.140	.160	3
ØP	3.54	4.08	.139	.161	
Q	2.54	3.42	.100	.135	

**LEAD ASSIGNMENTS**

**HEXFET**

- 1.- GATE
- 2.- DRAIN
- 3.- SOURCE

**IGBTs, CoPACK**

- 1.- GATE
- 2.- COLLECTOR
- 3.- EMITTER

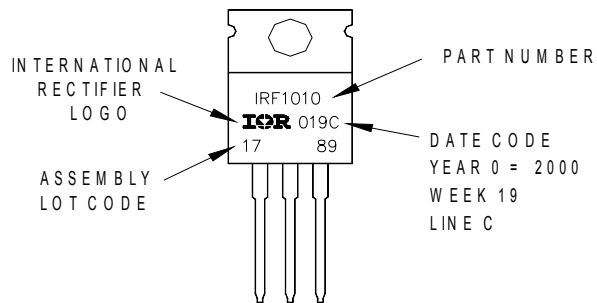
**DIODES**

- 1.- ANODE
- 2.- CATHODE
- 3.- ANODE

## TO-220AB Part Marking Information

EXAMPLE: THIS IS AN IRF1010  
 LOT CODE 1789  
 ASSEMBLED ON WW 19, 2000  
 IN THE ASSEMBLY LINE "C"

Note: "P" in assembly line position indicates "Lead - Free"

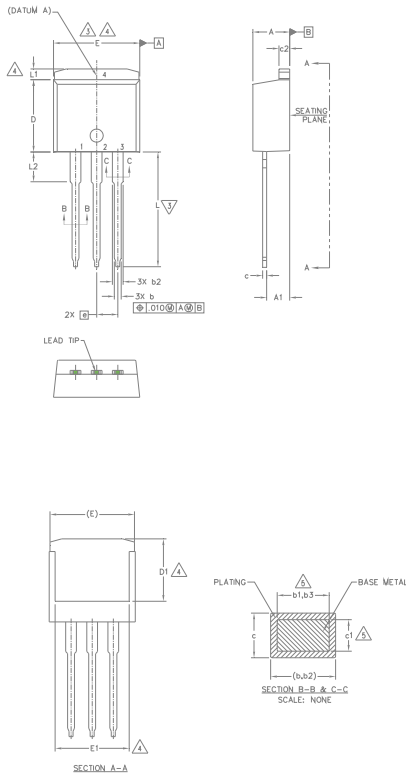


TO-220AB package is not recommended for Surface Mount Application.

Note: For the most current drawing please refer to IR website at <http://www.irf.com/package/>

# TO-262 Package Outline

Dimensions are shown in millimeters (inches)



SYMBOL	DIMENSIONS				NOTES
	MILLIMETERS		INCHES		
	MIN.	MAX.	MIN.	MAX.	
A	4.06	4.83	.160	.190	
A1	2.03	3.02	.080	.119	
b	0.51	0.99	.020	.039	
b1	0.51	0.89	.020	.035	5
b2	1.14	1.78	.045	.070	
b3	1.14	1.73	.045	.068	5
c	0.38	0.74	.015	.029	
c1	0.38	0.58	.015	.023	5
c2	1.14	1.65	.045	.065	
D	8.38	9.65	.330	.380	3
D1	6.86	-	.270	-	4
E	9.65	10.67	.380	.420	3,4
E1	6.22	-	.245	-	4
e	2.54 BSC		.100 BSC		
L	13.46	14.10	.530	.555	
L1	-	1.65	-	.065	4
L2	3.56	3.71	.140	.146	

**NOTES:**

1. DIMENSIONING AND TOLERANCING PER ASME Y14.5M-1994
2. DIMENSIONS ARE SHOWN IN MILLIMETERS [INCHES].
3. DIMENSION D & E DO NOT INCLUDE MOLD FLASH. MOLD FLASH SHALL NOT EXCEED 0.127 [0.005"] PER SIDE. THESE DIMENSIONS ARE MEASURED AT THE OUTMOST EXTREMES OF THE PLASTIC BODY.
4. THERMAL PAD CONTOUR OPTIONAL WITHIN DIMENSION E, L1, D1 & E1.
5. DIMENSION b1 AND c1 APPLY TO BASE METAL ONLY.
6. CONTROLLING DIMENSION: INCH.
7. OUTLINE CONFORM TO JEDEC TO-262 EXCEPT A1(max.), b(min.) AND D1(min.) WHERE DIMENSIONS DERIVED THE ACTUAL PACKAGE OUTLINE.

**LEAD ASSIGNMENTS**

**IGBTs, CoPACK**

- 1.- GATE
- 2.- COLLECTOR
- 3.- EMITTER
- 4.- COLLECTOR

**HEXFET**

- 1.- GATE
- 2.- DRAIN
- 3.- SOURCE
- 4.- DRAIN

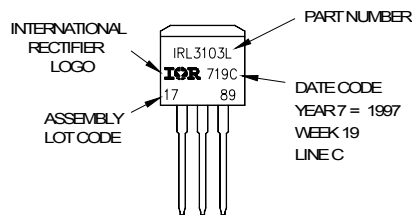
**DIODES**

- 1.- ANODE (TWO DIE) / OPEN (ONE DIE)
- 2, 4.- CATHODE
- 3.- ANODE

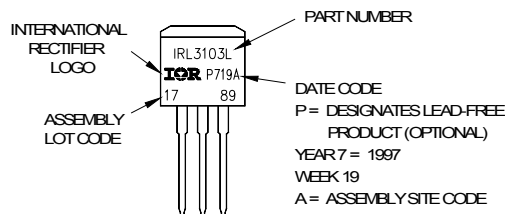
# TO-262 Part Marking Information

EXAMPLE: THIS IS AN IRL3103L  
 LOT CODE 1789  
 ASSEMBLED ON VWV19, 1997  
 IN THE ASSEMBLY LINE "C"

Note: "P" in assembly line position indicates "Lead - Free"



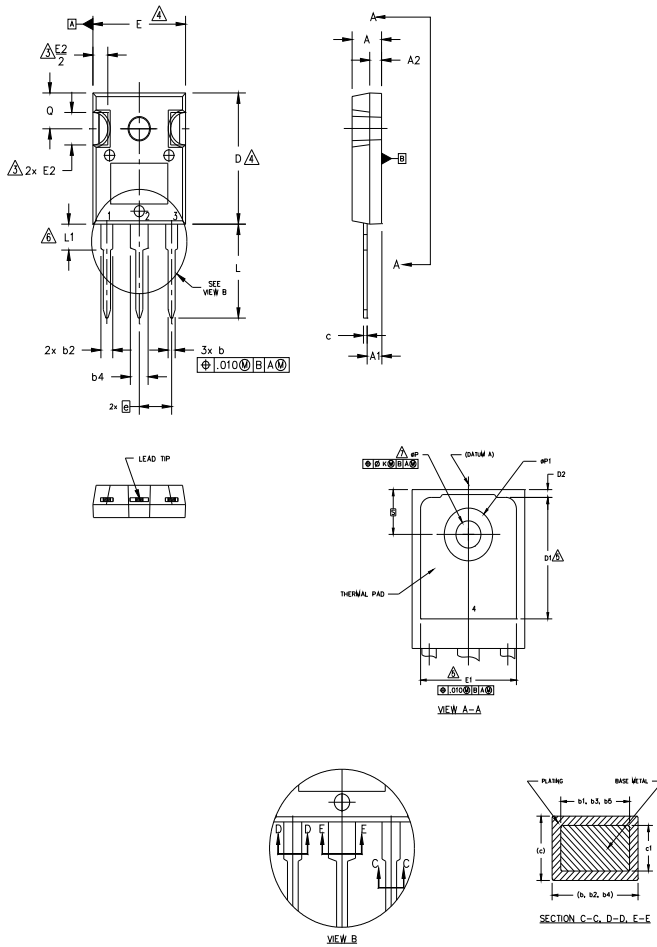
**OR**



Note: For the most current drawing please refer to IR website at <http://www.irf.com/package/>

# TO-247AC Package Outline

Dimensions are shown in millimeters (inches)



**NOTES:**

1. DIMENSIONING AND TOLERANCING AS PER ASME Y14.5M 1994.
2. DIMENSIONS ARE SHOWN IN INCHES.
3. CONTOUR OF SLOT OPTIONAL.
4. DIMENSION D & E DO NOT INCLUDE MOLD FLASH. MOLD FLASH SHALL NOT EXCEED .005" (0.127) PER SIDE. THESE DIMENSIONS ARE MEASURED AT THE OUTERMOST EXTREMES OF THE PLASTIC BODY.
5. THERMAL PAD CONTOUR OPTIONAL WITHIN DIMENSIONS D1 & E1.
6. LEAD FINISH UNCONTROLLED IN L1.
7. ØP TO HAVE A MAXIMUM DRAFT ANGLE OF 1.5 ° TO THE TOP OF THE PART WITH A MAXIMUM HOLE DIAMETER OF .154 INCH.
8. OUTLINE CONFORMS TO JEDEC OUTLINE TO-247AC .

SYMBOL	DIMENSIONS				NOTES
	INCHES		MILLIMETERS		
	MIN.	MAX.	MIN.	MAX.	
A	.183	.209	4.65	5.31	
A1	.087	.102	2.21	2.59	
A2	.059	.098	1.50	2.49	
b	.039	.055	0.99	1.40	
b1	.039	.053	0.99	1.36	
b2	.065	.094	1.65	2.39	
b3	.065	.092	1.65	2.34	
b4	.102	.135	2.59	3.43	
b5	.102	.133	2.59	3.38	
c	.015	.035	0.38	0.89	
c1	.015	.033	0.38	0.84	
D	.776	.815	19.71	20.70	4
D1	.515	-	13.08	-	5
D2	.020	.053	0.51	1.35	
E	.602	.625	15.29	15.87	4
E1	.530	-	13.46	-	
E2	.178	.216	4.52	5.49	
e	.215 BSC		5.46 BSC		
Øk	.010		0.25		
L	.559	.634	14.20	16.10	
L1	.146	.169	3.71	4.29	
ØP	.140	.144	3.56	3.66	
ØP1	-	.291	-	7.39	
Q	.209	.224	5.31	5.69	
S	.217 BSC		5.51 BSC		

LEAD ASSIGNMENTS

HEXFET

- 1.- GATE
- 2.- DRAIN
- 3.- SOURCE
- 4.- DRAIN

IGBTs, CoPACK

- 1.- GATE
- 2.- COLLECTOR
- 3.- EMITTER
- 4.- COLLECTOR

DIODES

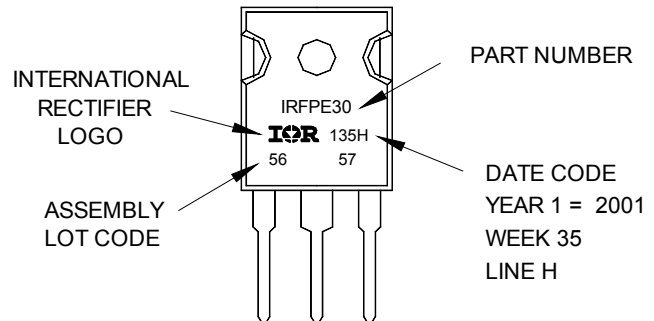
- 1.- ANODE/OPEN
- 2.- CATHODE
- 3.- ANODE

## TO-247AC Part Marking Information

Notes: This part marking information applies to devices produced after 02/26/2001

EXAMPLE: THIS IS AN IRFPE30  
WITH ASSEMBLY  
LOT CODE 5657  
ASSEMBLED ON WW 35, 2001  
IN THE ASSEMBLY LINE "H"

Note: "P" in assembly line position  
indicates "Lead-Free"

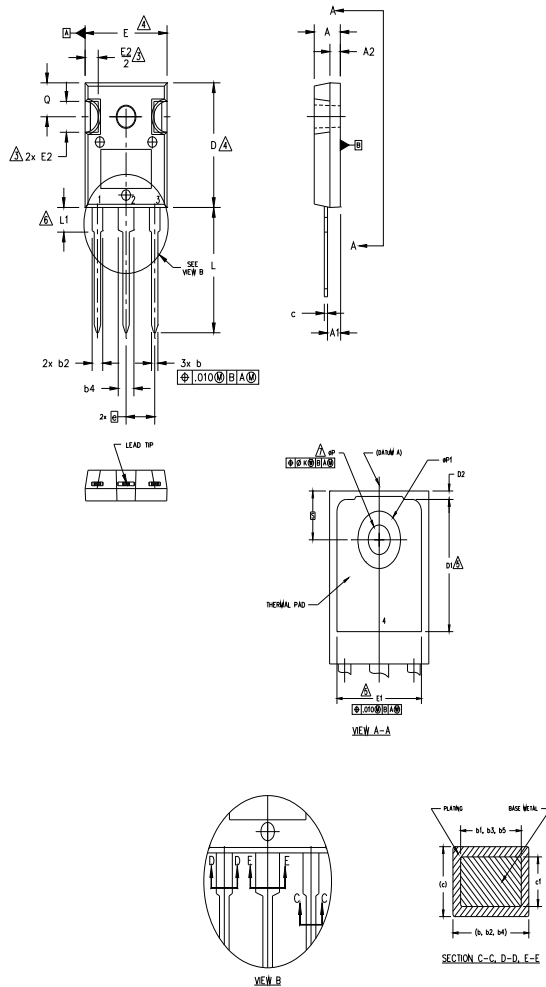


TO-247AC package is not recommended for Surface Mount Application.

Note: For the most current drawing please refer to IR website at <http://www.irf.com/package/>

# TO-247AD Package Outline

Dimensions are shown in millimeters (inches)



**NOTES:**

1. DIMENSIONING AND TOLERANCING AS PER ASME Y14.5M 1994.
2. DIMENSIONS ARE SHOWN IN INCHES.
3. CONTOUR OF SLOT OPTIONAL.
4. DIMENSION D & E DO NOT INCLUDE MOLD FLASH. MOLD FLASH SHALL NOT EXCEED .005" (0.127) PER SIDE. THESE DIMENSIONS ARE MEASURED AT THE OUTERMOST EXTREMES OF THE PLASTIC BODY.
5. THERMAL PAD CONTOUR OPTIONAL WITHIN DIMENSIONS D1 & E1.
6. LEAD FINISH UNCONTROLLED IN L1.
7.  $\phi P$  TO HAVE A MAXIMUM DRAFT ANGLE OF 1.5 ° TO THE TOP OF THE PART WITH A MAXIMUM HOLE DIAMETER OF .154 INCH.
8. OUTLINE CONFORMS TO JEDEC OUTLINE TO-247AD.

SYMBOL	DIMENSIONS				NOTES
	INCHES		MILLIMETERS		
	MIN.	MAX.	MIN.	MAX.	
A	.183	.209	4.65	5.31	
A1	.087	.102	2.21	2.59	
A2	.059	.098	1.50	2.49	
b	.039	.055	0.99	1.40	
b1	.039	.053	0.99	1.35	
b2	.065	.094	1.65	2.39	
b3	.065	.092	1.65	2.34	
b4	.102	.135	2.59	3.43	
b5	.102	.133	2.59	3.38	
c	.015	.035	0.38	0.89	
c1	.015	.033	0.38	0.84	
D	.776	.815	19.71	20.70	4
D1	.515	-	13.08	-	5
D2	.020	.053	0.51	1.35	
E	.602	.625	15.29	15.87	4
E1	.530	-	13.46	-	
E2	.178	.216	4.52	5.49	
e	.215 BSC		5.46 BSC		
$\phi k$	.010		0.25		
L	.780	.827	19.57	21.00	
L1	.146	.169	3.71	4.29	
$\phi P$	.140	.144	3.56	3.66	
$\phi P1$	-	.291	-	7.39	
Q	.209	.224	5.31	5.69	
S	.217 BSC		5.51 BSC		

**LEAD ASSIGNMENTS**

**HEXFET**

- 1.- GATE
- 2.- DRAIN
- 3.- SOURCE
- 4.- DRAIN

**IGBTs, CoPACK**

- 1.- GATE
- 2.- COLLECTOR
- 3.- EMITTER
- 4.- COLLECTOR

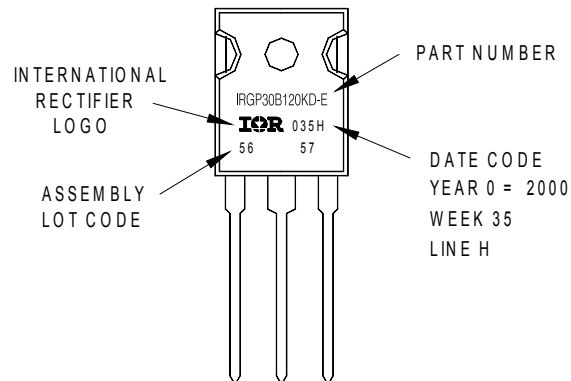
**DIODES**

- 1.- ANODE/OPEN
- 2.- CATHODE
- 3.- ANODE

## TO-247AD Part Marking Information

EXAMPLE: THIS IS AN IRGP30B120KD-E  
WITH ASSEMBLY  
LOT CODE 5657  
ASSEMBLED ON WW 35, 2000  
IN THE ASSEMBLY LINE "H"

Note: "P" in assembly line position  
indicates "Lead-Free"



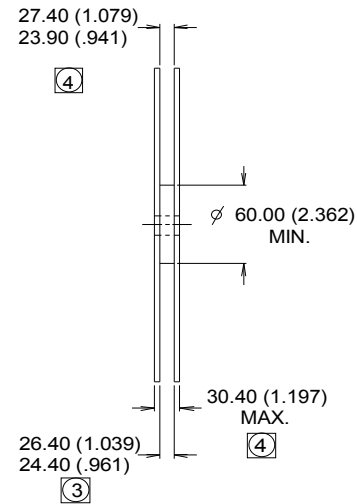
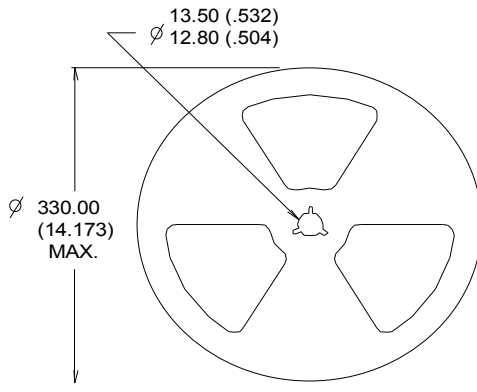
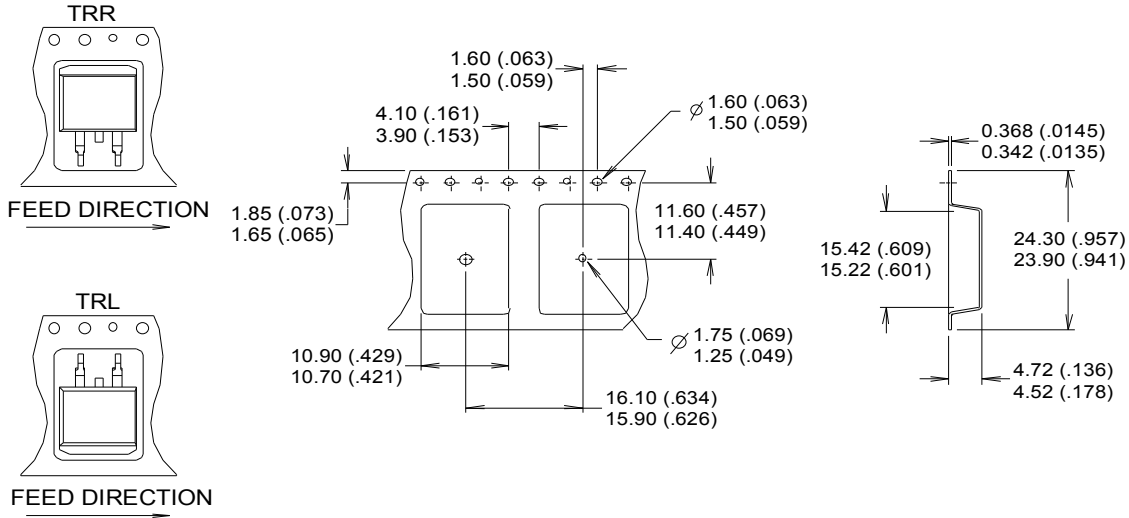
TO-247AD package is not recommended for Surface Mount Application.

Note: For the most current drawing please refer to IR website at <http://www.irf.com/package/>



# D<sup>2</sup>Pak Tape & Reel Information

(Dimensions are shown in millimeters (inches))



- NOTES :
1. COMFORMS TO EIA-418.
  2. CONTROLLING DIMENSION: MILLIMETER.
  3. DIMENSION MEASURED @ HUB.
  4. INCLUDES FLANGE DISTORTION @ OUTER EDGE.

Note: For the most current drawing please refer to IR website at <http://www.irf.com/package/>

**Qualification Information<sup>†</sup>**

<b>Qualification Level</b>	Industrial (per JEDEC JESD47F) <sup>††</sup>	
<b>Moisture Sensitivity Level</b>	D <sup>2</sup> Pak	MSL1
	TO-220AB	N/A
	TO-262	N/A
	TO-247AC	N/A
	TO-247AD	N/A
<b>RoHS Compliant</b>	Yes	

† Qualification standards can be found at International Rectifier’s web site: <http://www.irf.com/product-info/reliability/>

†† Applicable version of JEDEC standard at the time of product release.