

**GENERAL DESCRIPTION**

The XRT83SL216 is a fully integrated 16-channel E1 short-haul LIU which optimizes system cost and performance by offering key design features. The XRT83SL216 operates from a single 3.3V power supply. The LIU features are programmed through a standard serial microprocessor interface. EXAR's LIU has patented high impedance circuits that allow the transmitter outputs and receiver inputs to be placed in a high impedance mode when experiencing a power failure or when the LIU is powered off. Additional features include TAOS for transmit and receive, RLOS, LCV, on chip Jitter Attenuator, AIS detector, and diagnostic loopback modes.

**APPLICATIONS**

- ISDN Primary Rate Interface
- CSU/DSU E1 Interface
- E1 LAN/WAN Routers
- Public Switching Systems and PBX Interfaces
- E1 Multiplexer and Channel Banks
- Integrated Multi-Service Access Platforms (IMAPs)
- Integrated Access Devices (IADs)
- Inverse Multiplexing for ATM (IMA) Wireless Base Stations

**FIGURE 1. BLOCK DIAGRAM OF THE XRT83SL216**

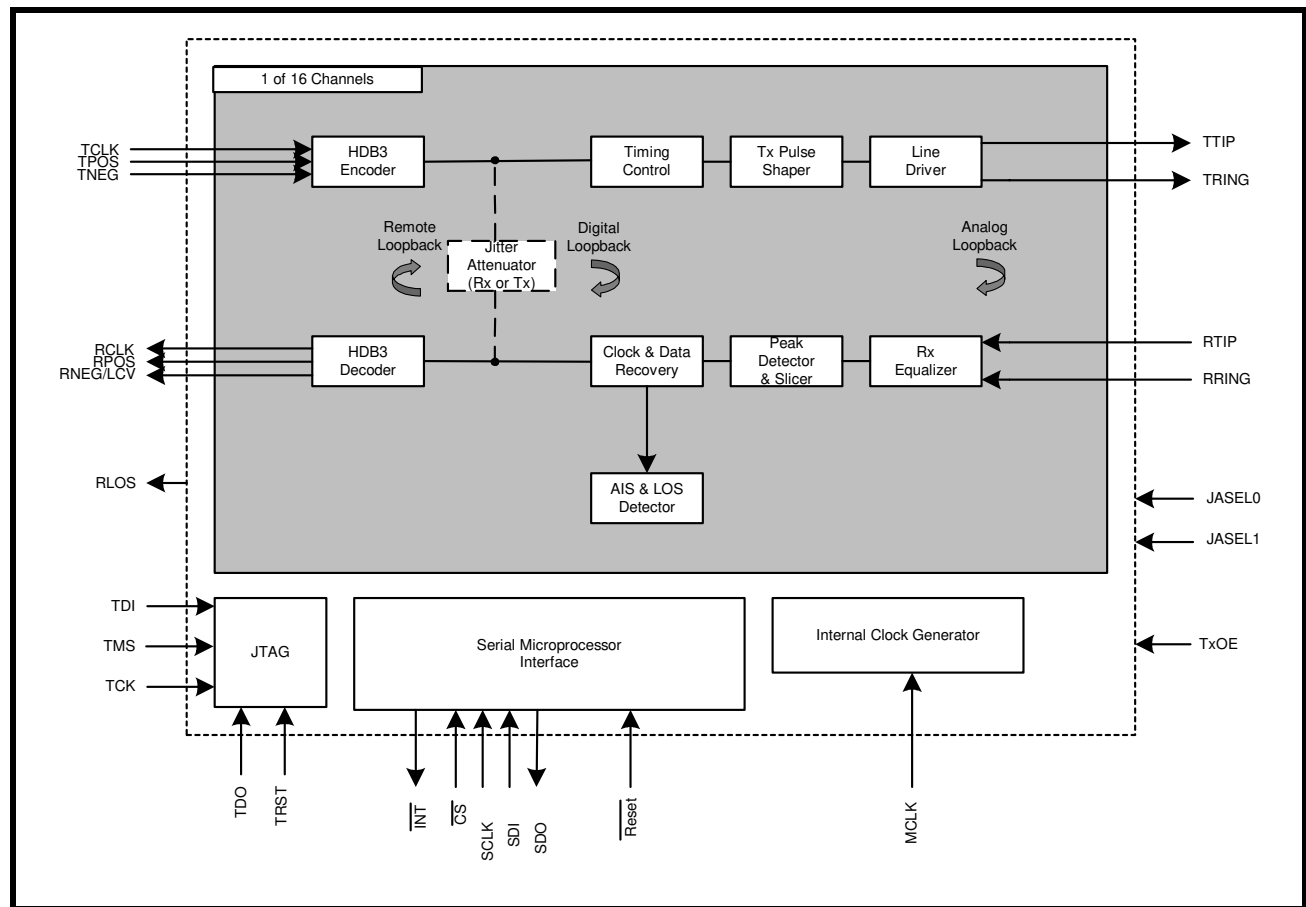

# XRT83SL216

## 16-CHANNEL E1 SHORT-HAUL LINE INTERFACE UNIT

### FEATURES

- Fully integrated 16-Channel short haul transceivers for E1 (2.048MHz) applications
- Tri-State on a per channel basis for the transmit selection
- Crystal-Less digital jitter attenuators (JA) with 32-Bit or 64-Bit FIFO for the receive or transmit paths
- Transmit outputs and receive inputs stay in the High Impedance mode upon power failure
- Support for automatic protection switching
- RLOS/AIS according to ITU-T G.775 or ETSI-300-233
- On-Chip HDB3 encoder/decoder for each channel
- On-Chip digital clock recovery circuit for high input jitter tolerance
- On-Chip per channel driver failure monitoring circuit
- On-Chip transmit pulse shaper for CEPT 75Ω and 120Ω line terminations
- High receiver interference immunity
- Transmit return loss meets or exceeds ETS1 300-166
- Meets or exceeds ITU G.703, G,775, G.736 and G.823
- Line code error and bipolar violation detection
- Transmit all ones (TAOS) for the Transmit and Receive Outputs
- Supports local analog, remote, and digital loopback modes
- Supports gapped clocks for mapper/multiplexer applications
- Low Power dissipation
- Single 3.3V supply operation (3V to 5V I/O tolerant)
- 289-Pin STBGA package
- -40°C to +85°C Temperature Range

### PRODUCT ORDERING INFORMATION

PRODUCT NUMBER	PACKAGE TYPE	OPERATING TEMPERATURE RANGE
XRT83SL2161B	289 Ball STBGA	-40°C to +85°C



## TABLE OF CONTENTS

<b>GENERAL DESCRIPTION .....</b>	<b>1</b>
<b>APPLICATIONS .....</b>	<b>1</b>
FIGURE 1. BLOCK DIAGRAM OF THE XRT83SL216 .....	1
<b>FEATURES .....</b>	<b>2</b>
<b>PRODUCT ORDERING INFORMATION .....</b>	<b>2</b>
FIGURE 2. PIN OUT FOR THE XRT83SL216 (BOTTOM VIEW) .....	3
<b>TABLE OF CONTENTS .....</b>	<b>1</b>
<b>PIN DESCRIPTIONS .....</b>	<b>4</b>
SERIAL MICROPROCESSOR INTERFACE .....	4
RECEIVER SECTION .....	5
TRANSMITTER SECTION .....	8
CONTROL FUNCTION .....	11
JTAG SECTION .....	11
POWER AND GROUND .....	12
<b>1.0 RECEIVE PATH LINE INTERFACE .....</b>	<b>15</b>
FIGURE 3. SIMPLIFIED BLOCK DIAGRAM OF THE RECEIVE PATH LINE TERMINATION (RTIP/RRING) .....	15
<b>1.1 PEAK DETECTOR/DATA SLICER .....</b>	<b>15</b>
<b>1.2 CLOCK AND DATA RECOVERY .....</b>	<b>15</b>
FIGURE 4. RECEIVE DATA UPDATED ON THE RISING EDGE OF RCLK .....	15
FIGURE 5. RECEIVE DATA UPDATED ON THE FALLING EDGE OF RCLK .....	15
TABLE 1: TIMING SPECIFICATIONS FOR RCLK/RPOS/RNEG .....	16
<b>1.3 RECEIVE SENSITIVITY .....</b>	<b>16</b>
FIGURE 6. TEST CONFIGURATION FOR MEASURING RECEIVE SENSITIVITY .....	16
<b>1.4 GENERAL ALARM DETECTION AND INTERRUPT GENERATION .....</b>	<b>16</b>
1.4.1 RLOS (RECEIVER LOSS OF SIGNAL) .....	17
1.4.2 AIS (ALARM INDICATION SIGNAL) .....	17
1.4.3 LCV (LINE CODE VIOLATION DETECTION) .....	17
<b>1.5 RECEIVE JITTER ATTENUATOR .....</b>	<b>17</b>
<b>1.6 HDB3 DECODER .....</b>	<b>17</b>
<b>1.7 ARAOS (AUTOMATIC RECEIVE ALL ONES) .....</b>	<b>18</b>
FIGURE 7. SIMPLIFIED BLOCK DIAGRAM OF THE ARAOS FUNCTION .....	18
<b>1.8 RPOS/RNEG/RCLK .....</b>	<b>18</b>
FIGURE 8. SINGLE RAIL MODE WITH A FIXED REPEATING "0011" PATTERN .....	18
FIGURE 9. DUAL RAIL MODE WITH A FIXED REPEATING "0011" PATTERN .....	18
<b>2.0 TRANSMIT PATH LINE INTERFACE .....</b>	<b>19</b>
FIGURE 10. SIMPLIFIED BLOCK DIAGRAM OF THE TRANSMIT PATH .....	19
<b>2.1 TCLK/TPOS/TNEG DIGITAL INPUTS .....</b>	<b>19</b>
FIGURE 11. TRANSMIT DATA SAMPLED ON FALLING EDGE OF TCLK .....	19
FIGURE 12. TRANSMIT DATA SAMPLED ON RISING EDGE OF TCLK .....	19
TABLE 2: TIMING SPECIFICATIONS FOR TCLK/TPOS/TNEG .....	20
<b>2.2 HDB3 ENCODER .....</b>	<b>20</b>
TABLE 3: EXAMPLES OF HDB3 ENCODING .....	20
<b>2.3 TRANSMIT JITTER ATTENUATOR .....</b>	<b>20</b>
TABLE 4: MAXIMUM GAP WIDTH FOR MULTIPLEXER/MAPPER APPLICATIONS .....	20
<b>2.4 TAOS (TRANSMIT ALL ONES) .....</b>	<b>21</b>
FIGURE 13. TAOS (TRANSMIT ALL ONES) .....	21
<b>2.5 ATAOS (AUTOMATIC TRANSMIT ALL ONES) .....</b>	<b>21</b>
FIGURE 14. SIMPLIFIED BLOCK DIAGRAM OF THE ATAOS FUNCTION .....	21
<b>3.0 APPLICATIONS .....</b>	<b>22</b>
<b>3.1 LOOPBACK DIAGNOSTICS .....</b>	<b>22</b>
<b>3.1.1 LOCAL ANALOG LOOPBACK .....</b>	<b>22</b>
FIGURE 15. SIMPLIFIED BLOCK DIAGRAM OF LOCAL ANALOG LOOPBACK .....	22
<b>3.1.2 REMOTE LOOPBACK .....</b>	<b>22</b>
FIGURE 16. SIMPLIFIED BLOCK DIAGRAM OF REMOTE LOOPBACK .....	22
<b>3.1.3 DIGITAL LOOPBACK .....</b>	<b>23</b>
FIGURE 17. SIMPLIFIED BLOCK DIAGRAM OF DIGITAL LOOPBACK .....	23
<b>3.2 INTERFACING THE TRANSMIT SECTION OF THE XRT83L216 TO THE LINE .....</b>	<b>23</b>
FIGURE 18. INTERFACING THE XRT83L216 TO THE LINE FOR 75W APPLICATIONS (1 CHANNEL SHOWN) .....	23
FIGURE 19. INTERFACING THE XRT83L216 TO THE LINE FOR 120 W APPLICATIONS (1CHANNEL SHOWN) .....	24

The following Ferrite Bead is Recommended for Use .....	24
The following Transformer is Recommended for Use .....	25
<b>4.0 SERIAL MICROPROCESSOR INTERFACE BLOCK .....</b>	<b>26</b>
FIGURE 20. SIMPLIFIED BLOCK DIAGRAM OF THE SERIAL MICROPROCESSOR INTERFACE .....	26
FIGURE 21. MICROPROCESSOR SERIAL INTERFACE STRUCTURE .....	26
FIGURE 22. TIMING DIAGRAM FOR THE MICROPROCESSOR SERIAL INTERFACE .....	27
TABLE 5: MICROPROCESSOR SERIAL INTERFACE TIMINGS ( TA = 250C, VDD=3.3V± 5% AND LOAD = 10PF) .....	27
TABLE 6: MICROPROCESSOR REGISTER DESCRIPTION .....	28
TABLE 7: MICROPROCESSOR REGISTER 0x00H BIT DESCRIPTION .....	30
TABLE 8: MICROPROCESSOR REGISTERS 0x01H &0x02H BIT DESCRIPTION .....	31
TABLE 9: MICROPROCESSOR REGISTER 0x03H BIT DESCRIPTION .....	32
TABLE 10: MICROPROCESSOR REGISTERS 0x04H & 0x05H BIT DESCRIPTION .....	32
TABLE 11: MICROPROCESSOR REGISTER BIT DESCRIPTION .....	32
TABLE 12: MICROPROCESSOR REGISTER BIT DESCRIPTION .....	34
TABLE 13: MICROPROCESSOR REGISTER BIT DESCRIPTION .....	34
<b>ELECTRICAL CHARACTERISTICS.....</b>	<b>36</b>
TABLE 14: ABSOLUTE MAXIMUM RATINGS .....	36
TABLE 15: DC DIGITAL INPUT AND OUTPUT ELECTRICAL CHARACTERISTICS .....	36
TABLE 16: AC ELECTRICAL CHARACTERISTICS .....	36
TABLE 17: POWER CONSUMPTION .....	36
TABLE 18: RECEIVER ELECTRICAL CHARACTERISTICS .....	37
TABLE 19: E1 TRANSMITTER ELECTRICAL CHARACTERISTICS .....	38
<b>ORDERING INFORMATION .....</b>	<b>39</b>
<b>PACKAGE DIMENSIONS .....</b>	<b>39</b>
FIGURE 23. 15x15MM 289 BALL STBGA.....	39
REVISION HISTORY .....	40

## PIN DESCRIPTIONS

### HOST MODE INTERFACE

### SERIAL MICROPROCESSOR INTERFACE

NAME	PIN	TYPE	DESCRIPTION
$\overline{\text{CS}}$	J4	I	<b>Chip Select Input</b> Active low signal. This signal enables the serial microprocessor interface by pulling chip select "Low". The serial interface is disabled when the chip select signal returns "High".
SCLK	J5	I	<b>Serial Clock Input</b> The serial clock input samples SDI on the rising edge and updates SDO on the falling edge. See the Serial Microprocessor section of this datasheet for more details.
SDI	K5	I	<b>Serial Data Input</b> The serial data input pin is used to supply an address and data string to program the internal registers within the device. See the Serial Microprocessor section of this datasheet for more details.
SDO	L5	O	<b>Serial Data Output</b> The serial data output pin is used to retrieve the internal contents of a selected register in readback mode. See the Microprocessor section of this datasheet for more details.
$\overline{\text{Reset}}$	J6	I	<b>Hardware Reset Input</b> Active low signal. When this pin is pulled "Low" for more than 10 $\mu$ S, all internal registers and state machines are set to their default state. <b>NOTE:</b> Internally pulled "High" with 50k $\Omega$ .
$\overline{\text{INT}}$	K4	O	<b>Interrupt Output</b> Active low signal. This signal is asserted "Low" when a change in alarm status occurs. Once the status registers have been read, the interrupt pin will return "High". GIE (Global Interrupt Enable) must be set "High" in the appropriate global register to enable interrupt generation. <b>NOTE:</b> This pin is an open-drain output that requires an external 10K $\Omega$ pull-up resistor.

**RECEIVER SECTION**

NAME	PIN	TYPE	DESCRIPTION
RLOS15	B10	○	<p><b>Receive Loss of Signal</b></p> <p>When a receive loss of signal occurs, the RLOS pin will go "High" for a minimum of one RCLK cycle. RLOS will remain "High" until the loss of signal condition clears. See the Receive Loss of Signal section of this datasheet for more details.</p>
RLOS14	D11		
RLOS13	F10		
RLOS12	B12		
RLOS11	T12		
RLOS10	T11		
RLOS9	M10		
RLOS8	R10		
RLOS7	U8		
RLOS6	R7		
RLOS5	M8		
RLOS4	T6		
RLOS3	B6		
RLOS2	B7		
RLOS1	F8		
RLOS0	C8		
RCLK15	A10	○	<p><b>Receive Clock Output</b></p> <p>RCLK is the recovered clock from the incoming data stream. If the incoming signal is absent, RCLK maintains its timing by using an internal master clock as its reference. RPOS/RNEG data can be updated on either edge of RCLK selected by RCLKinv in the appropriate channel register.</p>
RCLK14	A11		
RCLK13	E10		
RCLK12	A12		
RCLK11	U12		
RCLK10	U11		
RCLK9	N10		
RCLK8	P10		
RCLK7	T8		
RCLK6	P7		
RCLK5	N8		
RCLK4	U6		
RCLK3	A6		
RCLK2	A7		
RCLK1	E8		
RCLK0	D8		

**RECEIVER SECTION**

NAME	PIN	TYPE	DESCRIPTION
RPOS15	C10	○	<b>RPOS/RDATA Output</b> Receive digital output pin. In dual rail mode, this pin is the receive positive data output. In single rail mode, this pin is the receive non-return to zero (NRZ) data output.
RPOS14	C11		
RPOS13	E11		
RPOS12	C12		
RPOS11	R12		
RPOS10	R11		
RPOS9	M11		
RPOS8	T10		
RPOS7	R8		
RPOS6	T7		
RPOS5	N7		
RPOS4	R6		
RPOS3	C6		
RPOS2	C7		
RPOS1	F7		
RPOS0	A8		
RNEG/LCV15	D10	○	<b>RNEG/LCV Output</b> In dual rail mode, this pin is the receive negative data output. In single rail mode, this pin is a Line Code Violation indicator. If a line code violation or a bipolar violation occur, the LCV pin will pull "High" for a minimum of one RCLK cycle. LCV will remain "High" until there are no more violations. If AMI coding is selected, every bipolar violation will cause this pin to go "High".
RNEG/LCV14	B11		
RNEG/LCV13	F11		
RNEG/LCV12	D12		
RNEG/LCV11	P12		
RNEG/LCV10	P11		
RNEG/LCV9	N11		
RNEG/LCV8	U10		
RNEG/LCV7	P8		
RNEG/LCV6	U7		
RNEG/LCV5	M7		
RNEG/LCV4	P6		
RNEG/LCV3	D6		
RNEG/LCV2	D7		
RNEG/LCV1	E7		
RNEG/LCV0	B8		



**RECEIVER SECTION**

NAME	PIN	TYPE	DESCRIPTION
RTIP15	B17	I	<b>Receive Differential Tip Input</b> RTIP is the positive differential input from the line interface. Along with the RRING signal, these pins should be coupled to a 2:1 transformer for proper operation.
RTIP14	D17		
RTIP13	F17		
RTIP12	H17		
RTIP11	K17		
RTIP10	M17		
RTIP9	P17		
RTIP8	T17		
RTIP7	T1		
RTIP6	P1		
RTIP5	M1		
RTIP4	K1		
RTIP3	H1		
RTIP2	F1		
RTIP1	D1		
RTIP0	B1		
RRING15	C17	I	<b>Receive Differential Ring Input</b> RRING is the negative differential input from the line interface. Along with the RTIP signal, these pins should be coupled to a 2:1 transformer for proper operation.
RRING14	E17		
RRING13	G17		
RRING12	J17		
RRING11	L17		
RRING10	N17		
RRING9	R17		
RRING8	T16		
RRING7	T2		
RRING6	R1		
RRING5	N1		
RRING4	L1		
RRING3	J1		
RRING2	G1		
RRING1	E1		
RRING0	C1		

**TRANSMITTER SECTION**

NAME	PIN	TYPE	DESCRIPTION
TxOE	K14	I	<p><b>Transmit Output Enable</b></p> <p>Upon power up, the transmitters are tri-stated. Enabling the transmitters is selected through the serial microprocessor interface by programming the appropriate channel register if this pin is pulled "High". If the TxOE pin is pulled "Low", all 16 transmitters are tri-stated.</p> <p><i>NOTE: TxOE is ideal for redundancy applications. See the Redundancy Applications Section of this datasheet for more details. Internally pulled "Low" with a 50kΩ resistor.</i></p>
TCLK15 TCLK14 TCLK13 TCLK12 TCLK11 TCLK10 TCLK9 TCLK8 TCLK7 TCLK6 TCLK5 TCLK4 TCLK3 TCLK2 TCLK1 TCLK0	A14 D13 C14 E14 N14 P13 U16 R13 R5 U2 P5 N4 E4 A3 F5 C5	I	<p><b>Transmit Clock Input</b></p> <p>TCLK is the input facility clock used to sample the incoming TPOS/TNEG data. TPOS/TNEG data can be sampled on either edge of TCLK selected by TCLK-inv in the appropriate channel register.</p>
TPOS15 TPOS14 TPOS13 TPOS12 TPOS11 TPOS10 TPOS9 TPOS8 TPOS7 TPOS6 TPOS5 TPOS4 TPOS3 TPOS2 TPOS1 TPOS0	B13 E13 A15 F13 M14 N13 U15 T13 T5 U3 N5 M4 D4 B4 D5 B5	I	<p><b>TPOS/TDATA Input</b></p> <p>Transmit digital input pin. In dual rail mode, this pin is the transmit positive data input. In single rail mode, this pin is the transmit non-return to zero (NRZ) data input.</p>

**TRANSMITTER SECTION**

NAME	PIN	TYPE	DESCRIPTION
TNEG15	A13	I	<b>Transmit Negative Data Input</b>
TNEG14	C13		In dual rail mode, this pin is the transmit negative data input. In single rail mode, this pin can be tied to ground.
TNEG13	B14		
TNEG12	D14		
TNEG11	L14		
TNEG10	M13		
TNEG9	U14		
TNEG8	U13		
TNEG7	U5		
TNEG6	U4		
TNEG5	M5		
TNEG4	L4		
TNEG3	C4		
TNEG2	A4		
TNEG1	E5		
TNEG0	A5		

**TRANSMITTER SECTION**

NAME	PIN	TYPE	DESCRIPTION
TTIP15	B15	○	<b>Transmit Differential Tip Output</b> TTIP is the positive differential output to the line interface. Along with the TRING signal, these pins should be coupled to a 1:2 step up transformer for proper operation.
TTIP14	D15		
TTIP13	F15		
TTIP12	H15		
TTIP11	K15		
TTIP10	M15		
TTIP9	P15		
TTIP8	T14		
TTIP7	T4		
TTIP6	P3		
TTIP5	M3		
TTIP4	K3		
TTIP3	H3		
TTIP2	F3		
TTIP1	D3		
TTIP0	B3		
TRING15	C15	○	<b>Transmit Differential Ring Output</b> TRING is the negative differential output to the line interface. Along with the TTIP signal, these pins should be coupled to a 1:2 step up transformer for proper operation.
TRING14	E15		
TRING13	G15		
TRING12	J15		
TRING11	L15		
TRING10	N15		
TRING9	R15		
TRING8	R14		
TRING7	R4		
TRING6	R3		
TRING5	N3		
TRING4	L3		
TRING3	J3		
TRING2	G3		
TRING1	E3		
TRING0	C3		

**CONTROL FUNCTION**

NAME	PIN	TYPE	DESCRIPTION															
JASEL0 JASEL1	G13 H13	I	<p><b>Jitter Attenuator Select:</b> The Jitter Attenuator can be selected to be in the Transmit or Receive path.</p> <table border="1"> <thead> <tr> <th>JASEL1</th> <th>JASEL0</th> <th>Jitter Attenuator State</th> </tr> </thead> <tbody> <tr> <td>0</td> <td>0</td> <td>JA Disabled</td> </tr> <tr> <td>0</td> <td>1</td> <td>JA in Tx Path</td> </tr> <tr> <td>1</td> <td>0</td> <td>JA in Rx Path</td> </tr> <tr> <td>1</td> <td>1</td> <td>JA Select is enabled through <math>\mu</math>P Control</td> </tr> </tbody> </table> <p><i>NOTE: Internally pulled "High" with a 50k<math>\Omega</math> resistor.</i></p>	JASEL1	JASEL0	Jitter Attenuator State	0	0	JA Disabled	0	1	JA in Tx Path	1	0	JA in Rx Path	1	1	JA Select is enabled through $\mu$ P Control
JASEL1	JASEL0	Jitter Attenuator State																
0	0	JA Disabled																
0	1	JA in Tx Path																
1	0	JA in Rx Path																
1	1	JA Select is enabled through $\mu$ P Control																
MCLK	L6	I	<p><b>Master Clock Input</b> This pin is used as the internal reference to the LIU. This clock must be 2.048MHz +/-50ppm.</p>															

**JTAG SECTION**

NAME	PIN	TYPE	DESCRIPTION
TCK	G5	I	<b>JTAG Test Clock input, Boundary Scan Clock input:</b>
TDI	G4	I	<p><b>JTAG Test Data input, Boundary Scan Test Data Input:</b> <i>NOTE: Internally pulled "High" with a 50k<math>\Omega</math> resistor.</i></p>
TDO	H5	O	<p><b>JTAG Test Data output:</b> Boundary Scan Test Data Output:</p>
TMS	G6	I	<p><b>JTAG Test Mode Select, Boundary Scan Test Mode Select input pin:</b> <i>NOTE: Internally pulled "High" with a 50k<math>\Omega</math> resistor.</i></p>
TRST	H4	I	<p><b>JTAG Test Mode Reset, Boundary Scan Mode Reset Input pin:</b> <i>NOTE: This input pin should be pulled "Low" for normal operation. Internally pulled "High" with a 50k<math>\Omega</math> resistor.</i></p>

**POWER AND GROUND**

NAME	PIN	TYPE	DESCRIPTION
TVDD15 TVDD14 TVDD13 TVDD12 TVDD11 TVDD10 TVDD9 TVDD8 TVDD7 TVDD6 TVDD5 TVDD4 TVDD3 TVDD2 TVDD1 TVDD0	C16 E16 G16 J16 L16 N16 R16 P14 P4 R2 N2 L2 J2 G2 E2 C2	PWR	<b>Transmit Analog Power Supply (3.3V ±5%)</b> TVDD can be shared with DVDD. However, it is recommended that TVDD be isolated from the analog power supply RVDD. For best results, use an internal power plane for isolation. If an internal power plane is not available, a ferrite bead can be used. Each power supply pin should be bypassed to ground through an external 0.1µF capacitor and a 10µF capacitor.
RefVDD AVDD_pll	K12 K6	PWR	<b>Analog Power Supply (3.3V ±5%)</b> These analog supply pins should not be shared with other power supplies. It is recommended that they be isolated from the digital power supply, DVDD. For best results, use an internal power plane for isolation. If an internal power plane is not available, a ferrite bead can be used. Each power supply pin should be bypassed to ground through an external 0.1µF capacitor.
DVDD	A2 A17 C9 D9 H6 H12 P9 R9	PWR	<b>Digital Power Supply (3.3V ±5%)</b> DVDD should be isolated from the analog power supplies except for TVDD. For best results, use an internal power plane for isolation. If an internal power plane is not available, a ferrite bead can be used. Every two DVDD power supply pins should be bypassed to ground through at least one 0.1µF capacitor.
RVDD_1  RVDD_2	E9 F6 F9 F12 M6 M9 M12 N9	PWR	<b>Receive Power Supply (3.3V ±5%)</b> RVDD should be isolated from the digital power supplies. For best results, use an internal power plane for isolation. If an internal power plane is not available, a ferrite bead can be used. Each power supply pin should be bypassed to ground through at least one 0.1µF capacitor and a 10µF capacitor.

**POWER AND GROUND**

NAME	PIN	TYPE	DESCRIPTION
TGND15	B16	GND	<b>Transmit Analog Ground</b> It's recommended that all ground pins of this device be tied together and to a ground plane.
TGND14	D16		
TGND13	F16		
TGND12	H16		
TGND11	K16		
TGND10	M16		
TGND9	P16		
TGND8	T15		
TGND7	T3		
TGND6	P2		
TGND5	M2		
TGND4	K2		
TGND3	H2		
TGND2	F2		
TGND1	D2		
TGND0	B2		
DGND	A1 A9 A16 B9 T9 U1 U9 U17	GND	<b>Digital Ground</b> It's recommended that all ground pins of this device be tied together and to a ground plane.

**POWER AND GROUND**

NAME	PIN	TYPE	DESCRIPTION
AGND	G7 G8 G9 G10 G11 H7 H8 H9 H10 H11 J7 J8 J9 J10 J11 K7 K8 K9 K10 K11 L7 L8 L9 L10 L11 J14	GND	<p><b>Analog Ground</b>                      It's recommended that all ground pins of this device be tied together and to a ground plane.</p> <p><i>NOTE: J14 is a factory test pin and MUST be grounded for normal operation.</i></p>
NC	E6 E12 F4 F14 G12 G14 H14 J12 J13 K13 L12 L13 N6 N12	NC	<p><b>No Connects</b></p>



## 1.0 RECEIVE PATH LINE INTERFACE

The receive path consists of 16 independent E1 receivers. The following section describes the complete receive path from RTIP/RRING inputs to RCLK/RPOS/RNEG outputs. A simplified block diagram of the receive path is shown in **Figure 3**.

**FIGURE 3. SIMPLIFIED BLOCK DIAGRAM OF THE RECEIVE PATH LINE TERMINATION (RTIP/RRING)**

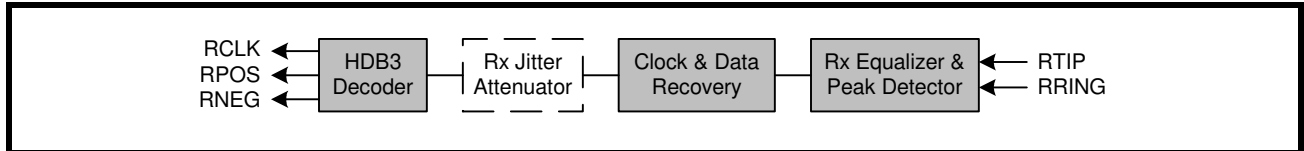

### 1.1 Peak Detector/Data Slicer

In the receive path, the line signal is coupled into the RTIP and RRING pins via a 2:1 transformer and are converted into digital pulses by an equalizer and an adaptive data slicer. Clock and data signals are recovered from the output of the slicer with the help of a digital PLL that provides excellent jitter accommodation for high input jitter tolerance.

### 1.2 Clock and Data Recovery

The receive clock (RCLK) is recovered by the clock and data recovery circuitry. An internal PLL locks on the incoming data stream and outputs a clock that's in phase with the incoming signal. In the absence of an incoming signal, RCLK maintains its timing by using MCLK as its reference. The recovered data can be updated on either edge of RCLK. By default, data is updated on the rising edge of RCLK. To update data on the falling edge of RCLK, set RCLKinv to "1" in the appropriate global register. **Figure 4** is a timing diagram of the receive data updated on the rising edge of RCLK. **Figure 5** is a timing diagram of the receive data updated on the falling edge of RCLK. The timing specifications are shown in **Table 1**.

**FIGURE 4. RECEIVE DATA UPDATED ON THE RISING EDGE OF RCLK**

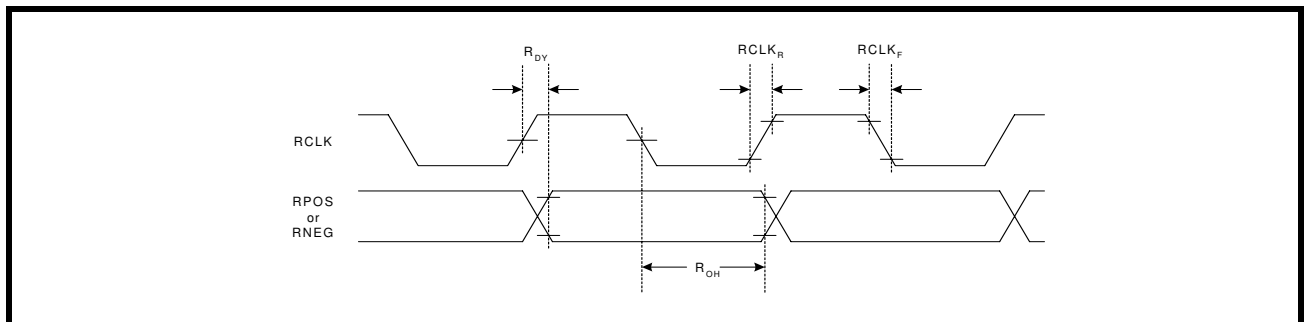

**FIGURE 5. RECEIVE DATA UPDATED ON THE FALLING EDGE OF RCLK**

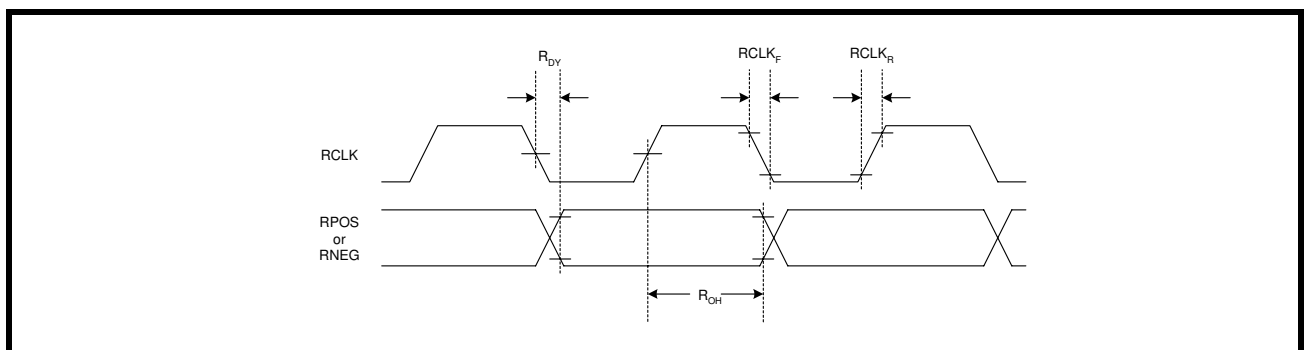

TABLE 1: TIMING SPECIFICATIONS FOR RCLK/RPOS/RNEG

PARAMETER	SYMBOL	MIN	TYP	MAX	UNITS
RCLK Duty Cycle	R <sub>CDU</sub>	45	50	55	%
Receive Data Setup Time	R <sub>SU</sub>	150	-	-	ns
Receive Data Hold Time	R <sub>HO</sub>	150	-	-	ns
RCLK to Data Delay	R <sub>DY</sub>	-	-	40	ns
RCLK Rise Time (10% to 90%) with 25pF Loading	RCLK <sub>R</sub>	-	-	40	ns
RCLK Fall Time (90% to 10%) with 25pF Loading	RCLK <sub>F</sub>	-	-	40	ns

NOTE: VDD=3.3V ±5%, T<sub>A</sub>=25°C, Unless Otherwise Specified

1.3 Receive Sensitivity

To meet short haul requirements, the XRT83SL216 can accept E1 signals that have been attenuated by 11dB of flat loss in E1 mode. The test configuration for measuring the receive sensitivity is shown in Figure 6.

FIGURE 6. TEST CONFIGURATION FOR MEASURING RECEIVE SENSITIVITY

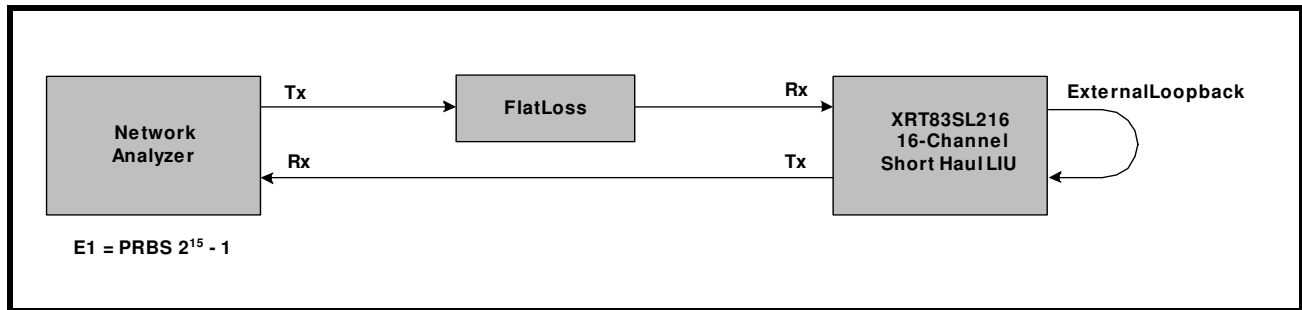

1.4 General Alarm Detection and Interrupt Generation

The receive path detects RLOS and AIS. These alarms can be individually masked to prevent the alarm from triggering an interrupt. To enable interrupt generation, the Global Interrupt Enable (GIE) bit must be set "High" in the appropriate global register. Any time a change in status occurs (if the alarms are enabled), the interrupt pin will pull "Low" to indicate an alarm has occurred. Once the status registers have been read, the INT pin will return "High". The status registers are Reset Upon Read (RUR).

NOTE: The interrupt pin is an Open-Drain output that requires a 10kΩ pull-up resistor.

#### **1.4.1 RLOS (Receiver Loss of Signal)**

The XRT83SL216 supports both G.775 or ETSI-300-233 RLOS detection scheme.

In G.775 mode, RLOS is declared when the received signal is less than 320mV for more than 32 consecutive pulse periods (typical). The device clears RLOS when the receive signal achieves 12.5% ones density with no more than 15 consecutive zeros in a 32 bit sliding window and the signal level exceeds 550mV (typical).

In ETSI-300-233 mode the device declares RLOS when the input level drops below 320mV (typical) for more than 2048 pulse periods (1msec). The device clears RLOS when the receive signal achieves 12.5% ones density with no more than 15 consecutive zeros in a 32 bit sliding window and the signal level exceeds 550mV (typical).

#### **1.4.2 AIS (Alarm Indication Signal)**

The XRT83SL216 adheres to ITU-T G.775 or ETSI-300-233 specifications for an all ones pattern detection by programming the appropriate channel register. The alarm indication signal is set to "1" if an all ones pattern is detected. In G.775 mode, AIS is defined as 2 or less zeros in 2 consecutive double frame (512-bit window) periods. AIS will clear when the incoming signal has 3 or more zeros in the same time period. In ETSI-300-233 mode, AIS is defined as less than 3 zeros in a 512-bit window.

#### **1.4.3 LCV (Line Code Violation Detection)**

In HDB3 mode, the LCV pin will be set to "High" if the receiver detects excessive zero's, bipolar violations or HDB3 code violations. If the device is configured in AMI mode, any bipolar violations will cause the LCV pin to go "High".

#### **1.5 Receive Jitter Attenuator**

The jitter attenuator can be configured in the receive path to reduce phase and frequency jitter in the recovered clock. The jitter attenuator uses a data FIFO (First In First Out) with a programmable depth of 32-bit or 64-bit. If the LIU is used for line synchronization (loop timing systems), the JA should be enabled. When the Read and Write pointers of the FIFO are within 2-Bits of over-flowing or under-flowing, the bandwidth of the jitter attenuator is widened to track the short term input jitter, thereby avoiding data corruption. When this condition occurs, the jitter attenuator will not attenuate input jitter until the Read/Write pointer's position is outside the 2-Bit window. The JA has a typical clock delay equal to ½ of the FIFO bit depth.

*NOTE: If the LIU is used in a multiplexer/mapper application where stuffing bits are typically removed, the JA can be configured in the transmit path to smooth out the gapped clock. See the Transmit Section of this datasheet.*

#### **1.6 HDB3 Decoder**

In single rail mode, RPOS is the output of decoded AMI or HDB3 signals and RNEG is the LCV output. HDB3 data is defined as any block of 4 successive zeros replaced with OOOV or BOOV, so that two successive V pulses are of opposite polarity to achieve zero DC offset. If the HDB3 decoder is selected, the receive path removes the V and B pulses so that the original data is output to RPOS.

**1.7 ARAOS (Automatic Receive All Ones)**

If ARAOS is enabled in the appropriate channel register and an RLOS condition occurs, the Receiver outputs will generate an All Ones pattern using MCLK as reference. When RLOS clears, the All Ones pattern ends and the Receive path returns to normal operation.

**FIGURE 7. SIMPLIFIED BLOCK DIAGRAM OF THE ARAOS FUNCTION**

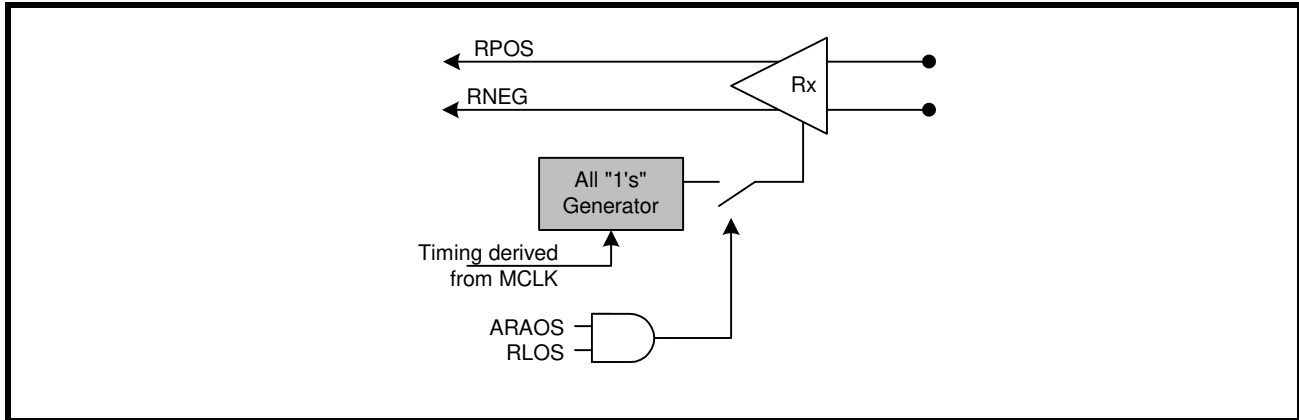

**1.8 RPOS/RNEG/RCLK**

The digital output data can be programmed to either single rail or dual rail formats. **Figure 8** is a timing diagram of a repeating "0011" pattern in single-rail mode. **Figure 9** is a timing diagram of the same fixed pattern in dual rail mode.

**FIGURE 8. SINGLE RAIL MODE WITH A FIXED REPEATING "0011" PATTERN**

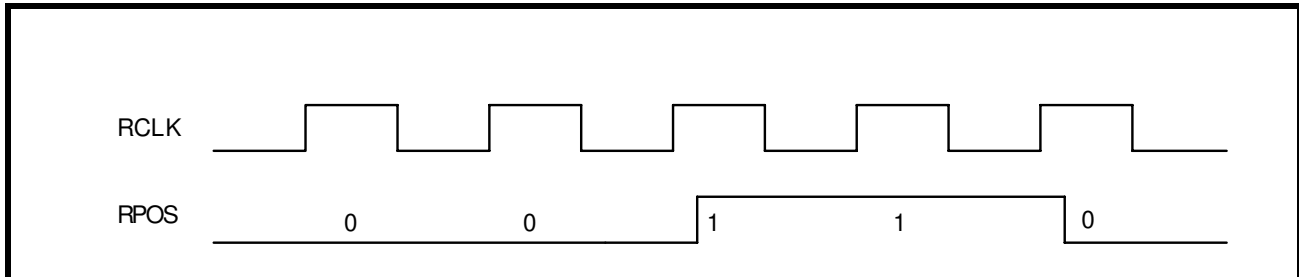

**FIGURE 9. DUAL RAIL MODE WITH A FIXED REPEATING "0011" PATTERN**

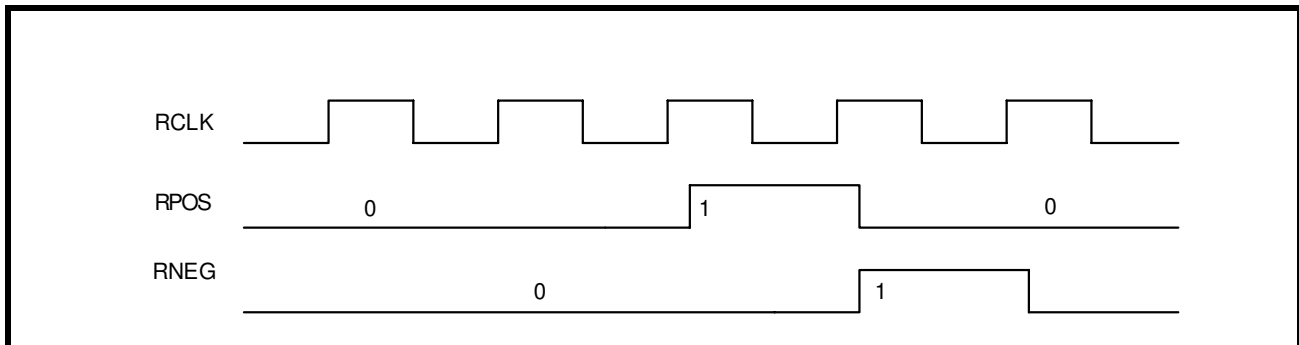

## 2.0 TRANSMIT PATH LINE INTERFACE

The transmit path consists of 16 independent E1 transmitters. The following section describes the complete transmit path from TCLK/TPOS/TNEG inputs to TTIP/TRING outputs. A simplified block diagram of the transmit path is shown in **Figure 10**.

**FIGURE 10. SIMPLIFIED BLOCK DIAGRAM OF THE TRANSMIT PATH**

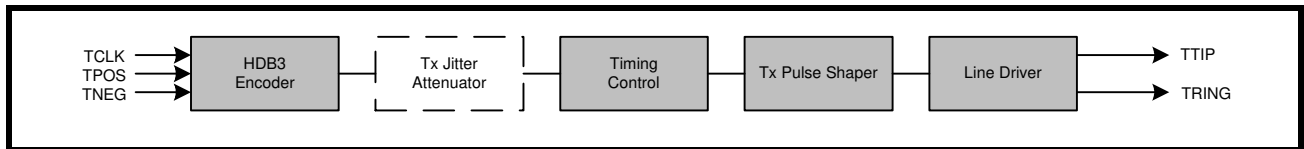

### 2.1 TCLK/TPOS/TNEG Digital Inputs

In dual rail mode, TPOS and TNEG are the digital inputs for the transmit path. In single rail mode, TNEG can be tied to ground. The XRT83SL216 can be programmed to sample the inputs on either edge of TCLK. By default, data is sampled on the falling edge of TCLK. To sample data on the rising edge of TCLK, set TCLKinv to "1" in the appropriate global register. **Figure 11** is a timing diagram of the transmit input data sampled on the falling edge of TCLK. **Figure 12** is a timing diagram of the transmit input data sampled on the rising edge of TCLK. The timing specifications are shown in **Table 2**.

**FIGURE 11. TRANSMIT DATA SAMPLED ON FALLING EDGE OF TCLK**

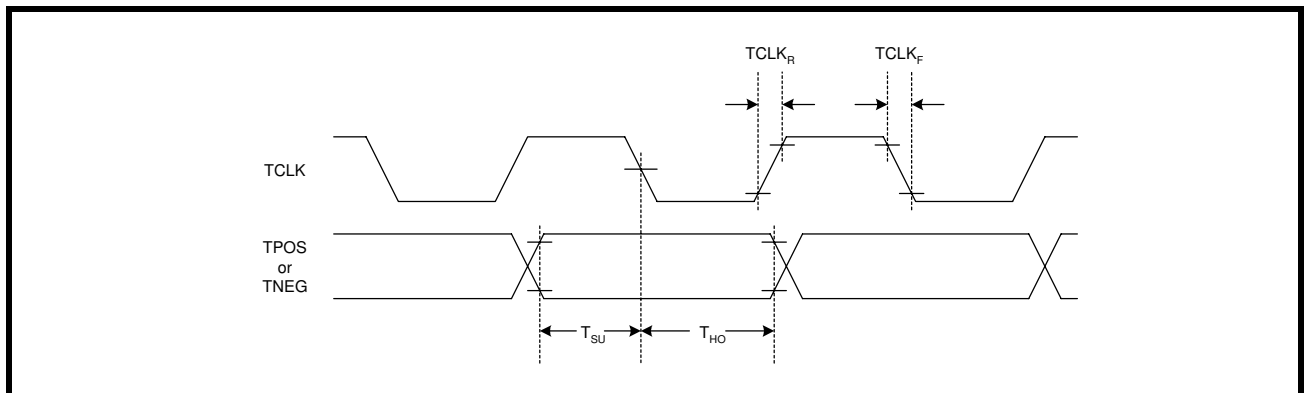

**FIGURE 12. TRANSMIT DATA SAMPLED ON RISING EDGE OF TCLK**

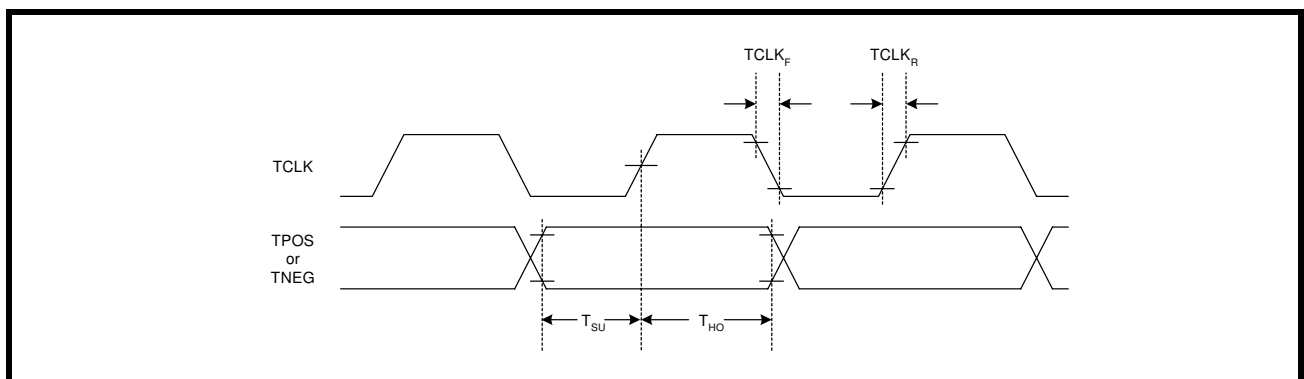

TABLE 2: TIMING SPECIFICATIONS FOR TCLK/TPOS/TNEG

PARAMETER	SYMBOL	MIN	TYP	MAX	UNITS
TCLK Duty Cycle	T <sub>CDU</sub>	30	50	70	%
Transmit Data Setup Time	T <sub>SU</sub>	50	-	-	ns
Transmit Data Hold Time	T <sub>HO</sub>	30	-	-	ns
TCLK Rise Time (10% to 90%)	TCLK <sub>R</sub>	-	-	40	ns
TCLK Fall Time (90% to 10%)	TCLK <sub>F</sub>	-	-	40	ns

**NOTE:** VDD=3.3V ±5%, T<sub>A</sub>=25°C, Unless Otherwise Specified

## 2.2 HDB3 Encoder

In single rail mode, the LIU can encode the TPOS input signal to AMI or HDB3 data. If HDB3 encoding is selected, any sequence with four or more consecutive zeros in the input will be replaced with 000V or B00V, where "B" indicates a pulse conforming to the bipolar rule and "V" representing a pulse violating the rule. An example of HDB3 encoding is shown in [Table 3](#).

TABLE 3: EXAMPLES OF HDB3 ENCODING

	NUMBER OF PULSES BEFORE NEXT 4 ZEROS	
Input		0000
HDB3 (Case 1)	Odd	000V
HDB3 (Case 2)	Even	B00V

## 2.3 Transmit Jitter Attenuator

The XRT83SL216 LIU is ideal for multiplexer or mapper applications where the network data crosses multiple timing domains. As the higher data rates are de-multiplexed to E1 data, stuffing bits are typically removed which can leave gaps in the incoming data stream. The JA can be configured in the transmit path with a 32-Bit or 64-Bit FIFO that is used to smooth the gapped clock into a steady E1 output. The maximum gap width the JA in the Transmit path can tolerate is shown in [Table 4](#).

TABLE 4: MAXIMUM GAP WIDTH FOR MULTIPLEXER/MAPPER APPLICATIONS

FIFO DEPTH	MAXIMUM GAP WIDTH
32-Bit	20 UI
64-Bit	50 UI

**NOTE:** If the LIU is used in a loop timing system, the JA should be configured in the receive path. See the Receive Section of this datasheet.

**2.4 TAOS (Transmit All Ones)**

The XRT83SL216 has the ability to transmit all ones on a per channel basis by programming the appropriate channel register. If TAOS is enabled, the Transmitter outputs will generate an All Ones pattern regardless of the Transmit Input data. The Remote Loop Back mode has priority over TAOS. **Figure 13** is a diagram showing the all ones signal at TTIP and TRING.

**FIGURE 13. TAOS (TRANSMIT ALL ONES)**

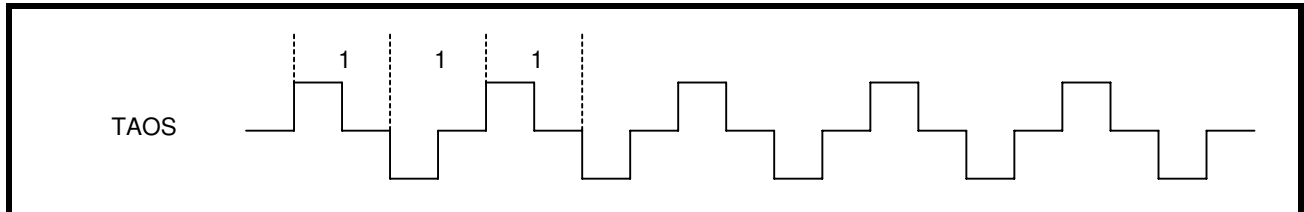

**2.5 ATAOS (Automatic Transmit All Ones)**

ATAOS is used to generate an All Ones signal only when an RLOS condition occurs. If ATAOS is enabled, any channel that experiences an RLOS condition will automatically cause the transmitter on that channel to send an All Ones Pattern to the line using MCLK as reference. When RLOS clears, the All Ones pattern ends and the Transmit path returns to normal operation.

**FIGURE 14. SIMPLIFIED BLOCK DIAGRAM OF THE ATAOS FUNCTION**

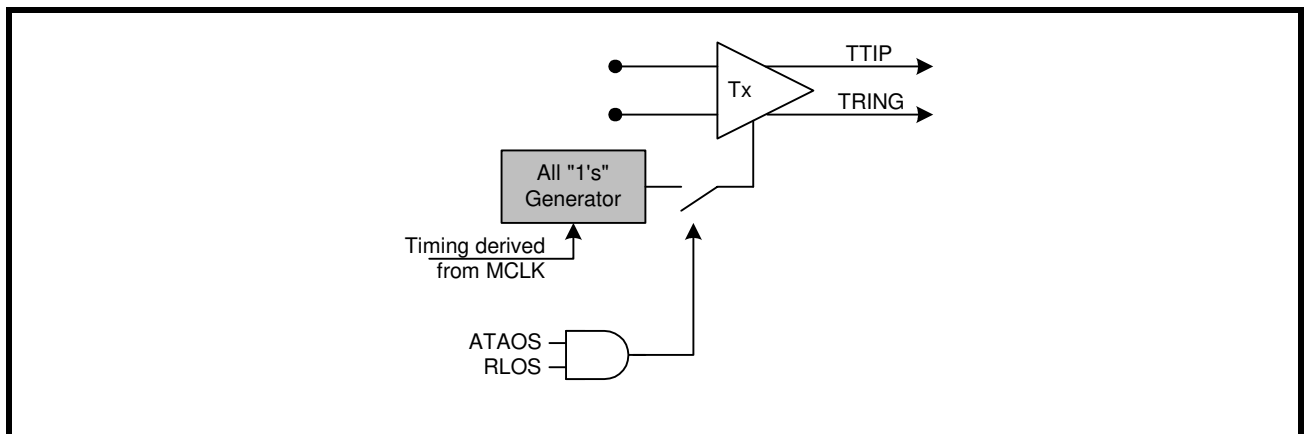

**3.0 APPLICATIONS**

This applications section describes system considerations along with references to application notes available for reference where applicable.

**3.1 Loopback Diagnostics**

The XRT83SL216 supports several loopback modes for diagnostic testing. The following section describes the local analog loopback, remote loopback, and digital loopback.

**3.1.1 Local Analog Loopback**

With local analog loopback activated, the transmit output data at TTIP/TRING is internally looped back to the analog inputs at RTIP/RRING. External inputs at RTIP/RRING are ignored while valid transmit output data continues to be sent to the line. A simplified block diagram of local analog loopback is shown in **Figure 15**.

**FIGURE 15. SIMPLIFIED BLOCK DIAGRAM OF LOCAL ANALOG LOOPBACK**

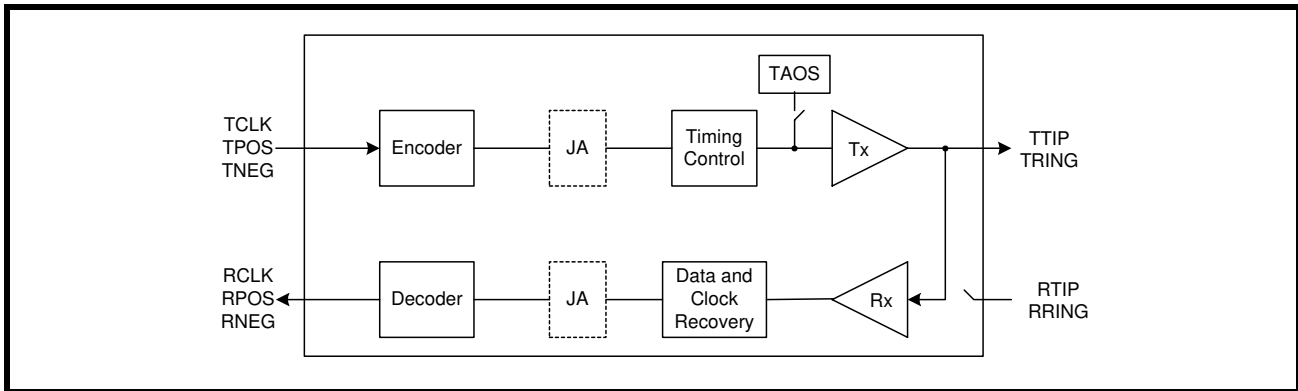

**NOTE:** TAOS takes priority over the transmit input data at TPOS/TNEG.

**3.1.2 Remote Loopback**

With remote loopback activated, the receive input data at RTIP/RRING is internally looped back to the transmit output data at TTIP/TRING. The transmit input data at TCLK/TPOS/TNEG are ignored while valid receive output data continues to be sent to the system. A simplified block diagram of remote loopback is shown in **Figure 16**.

**FIGURE 16. SIMPLIFIED BLOCK DIAGRAM OF REMOTE LOOPBACK**

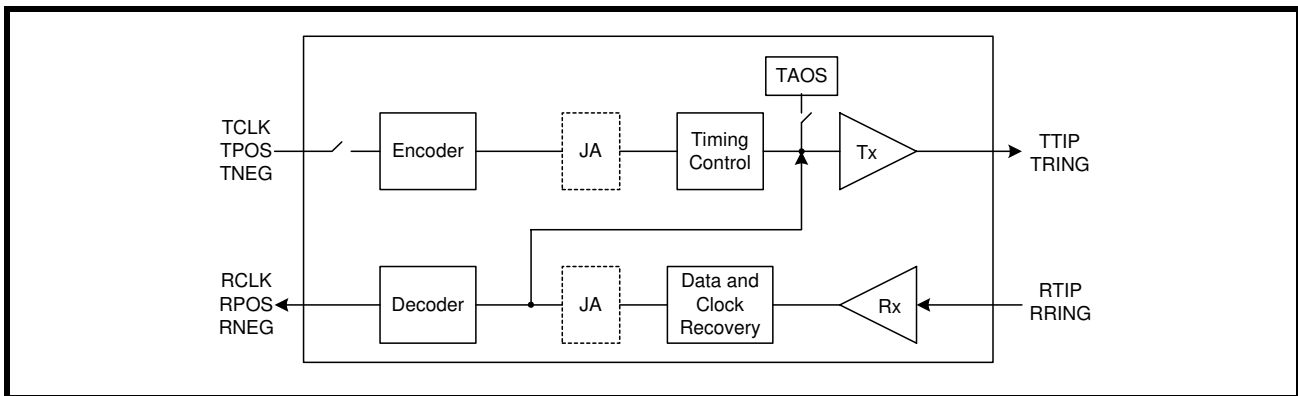

**NOTE:** Remote Loop Back takes priority over TAOS.



### 3.1.3 Digital Loopback

With digital loopback activated, the transmit input data at TCLK/TPOS/TNEG is looped back to the receive output data at RCLK/RPOS/RNEG. The receive input data at RTIP/RRING is ignored while valid transmit output data continues to be sent to the line. A simplified block diagram of digital loopback is shown in **Figure 17**.

**FIGURE 17. SIMPLIFIED BLOCK DIAGRAM OF DIGITAL LOOPBACK**

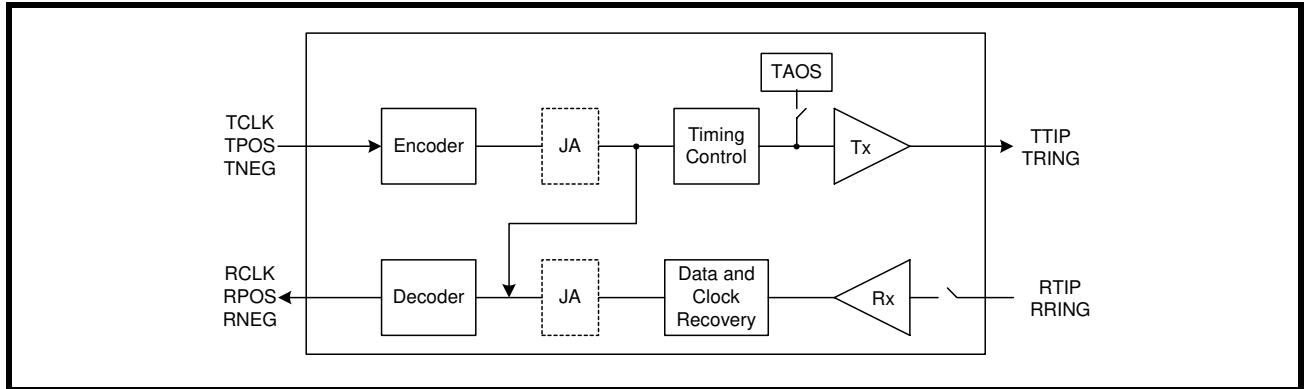

### 3.2 Interfacing the Transmit Section of the XRT83L216 to the Line

ITU-T G.703 specifies that the E1 line signal can be transmitted over coaxial cable and terminated with  $75\Omega$  or transmitted over twisted-pair and terminated with  $120\Omega$ .

In both applications (e.g.,  $75\Omega$  or  $120\Omega$ ), the user is advised to interface the Transmitter to the Line, in the manner as depicted in **Figure 18** and **Figure 19**, respectively.

**FIGURE 18. INTERFACING THE XRT83L216 TO THE LINE FOR  $75\Omega$  APPLICATIONS (1 CHANNEL SHOWN)**

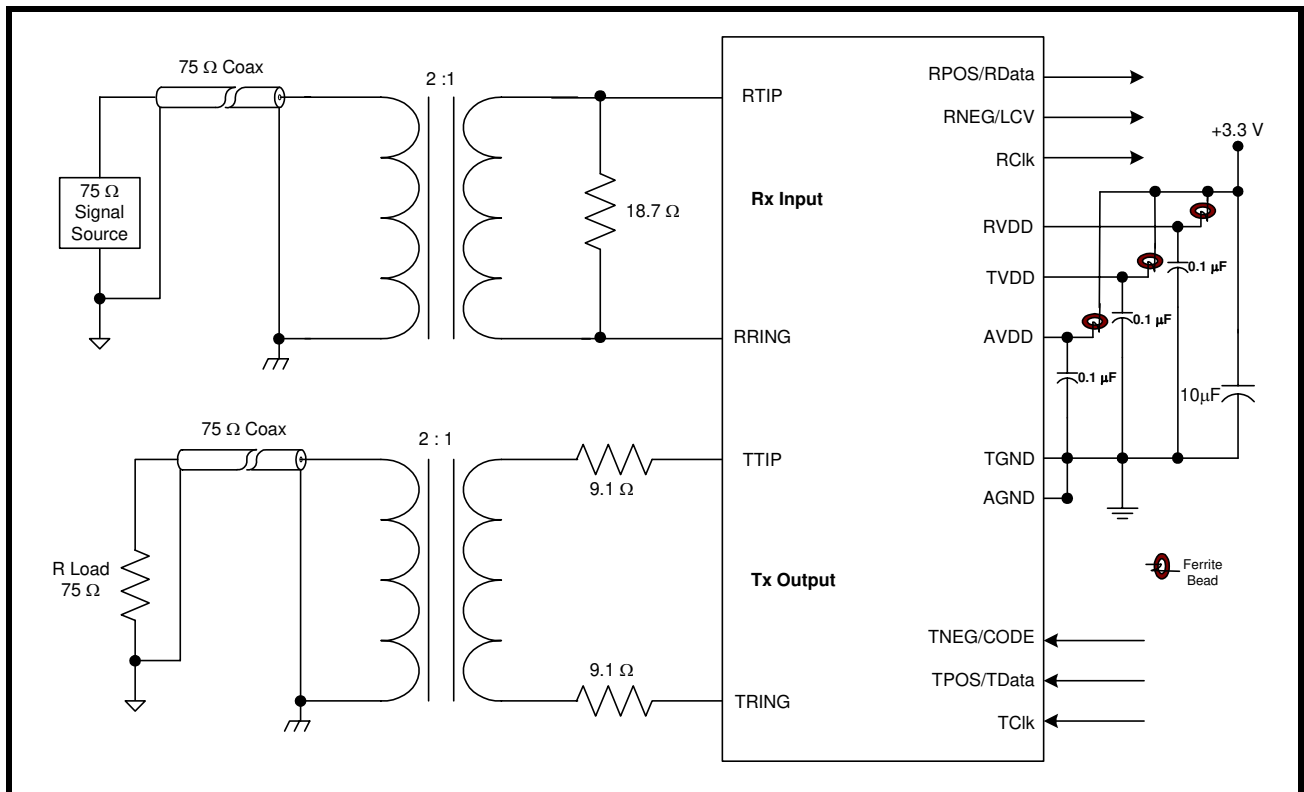
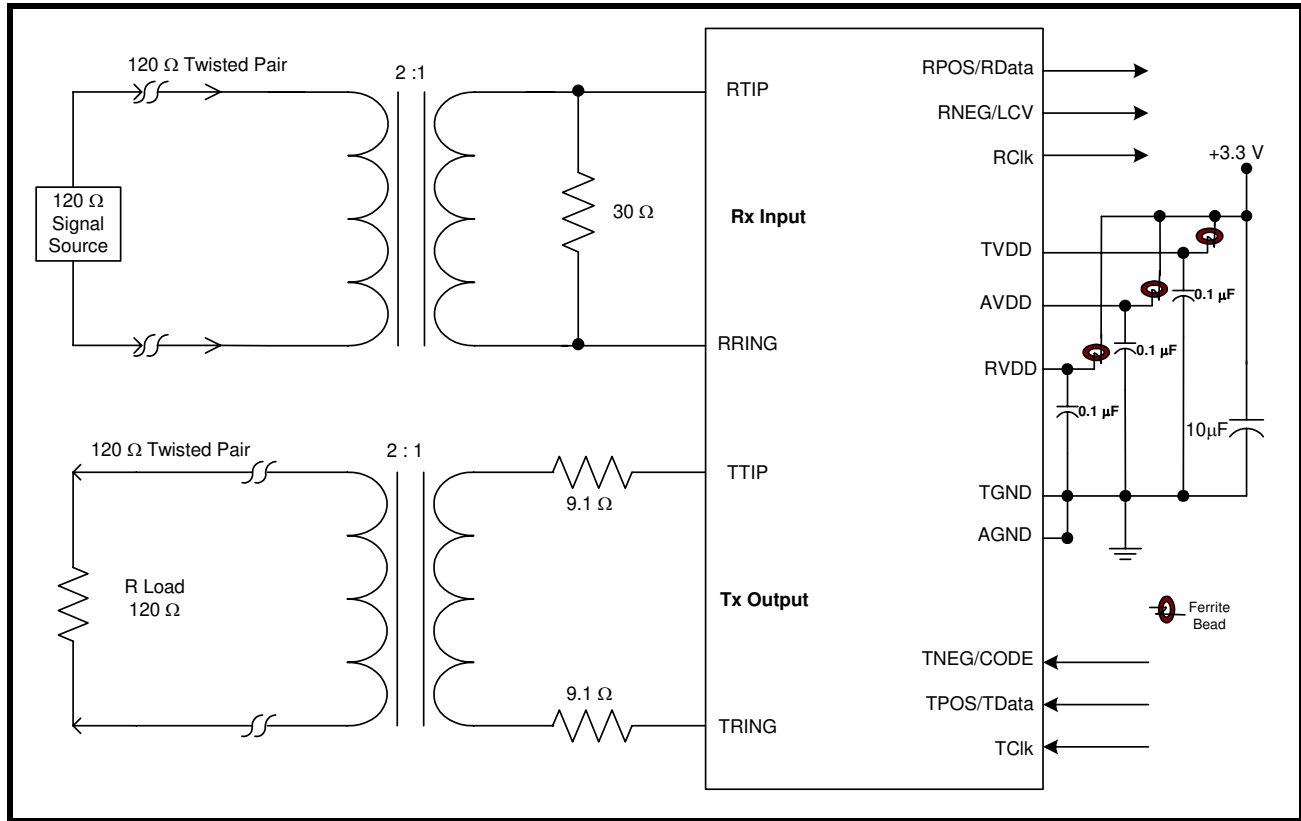

FIGURE 19. INTERFACING THE XRT83L216 TO THE LINE FOR 120 Ω APPLICATIONS (1 CHANNEL SHOWN)



THE FOLLOWING FERRITE BEAD IS RECOMMENDED FOR USE

PART NUMBER	VENDOR	TYP. IMPEDANCE @ 100MHZ	TYP. IMPEDANCE @ 200MHZ
HZ0402A601r-00	Steward	600Ω	925Ω

Supplier Information

Steward		
Corporate Office	Europe	Asia
P.O. Box 510 Chattanooga, TN 37401-510 Phone: +1 (423) 308-1690 Phone: (800) 634-2673 - Toll Free Fax: +1 (423) 308-1622	Brucefield Industrial Park Livingston EH9 9DR Scotland, UK Phone +44-[0]1-506-414200 Fax: +44-[0]1-506-410694	3791 Jalan Bukit Merah #10-14 E-Centre @ Redhill Singapore 159471 Phone: +65-6272-2646 Fax: +65-6272-6165

THE FOLLOWING TRANSFORMER IS RECOMMENDED FOR USE

PART NUMBER	VENDOR	TURNS RATIO	PACKAGE TYPE
T1113	Pulse	1:2 Transmit 2:1 Receive	TOU 2

**Magnetic Supplier Information**

**Supplier Information**

<b>PULSE</b>		
<i>Corporate Office</i>	<i>Europe</i>	<i>Asia</i>
12220 World Trade Drive San Diego, CA 92128 Tel: (619)-674-8100 FAX: (619)-674-8262	1 & 2 Huxley Road The Surrey Research Park Guildford, Surrey GU2 5RE United Kingdom Tel: 44-1483-401700 FAX: 44-1483-401701	150 Kampong Ampat #07-01/02 KA Centre Singapore 368324 Tel: 65-287-8998 FAX: 65-280-0080

**4.0 SERIAL MICROPROCESSOR INTERFACE BLOCK**

The serial microprocessor uses a standard 3-pin serial port with  $\overline{CS}$ , SCLK, and SDI for programming the LIU. Optional pins such as SDO,  $\overline{INT}$ , and  $\overline{RESET}$  allow the ability to read back contents of the registers, monitor the LIU via an interrupt pin, and reset the LIU to its default configuration by pulling reset "Low" for more than 10 $\mu$ S. A simplified block diagram of the Serial Microprocessor is shown in **Figure 20**.

**FIGURE 20. SIMPLIFIED BLOCK DIAGRAM OF THE SERIAL MICROPROCESSOR INTERFACE**

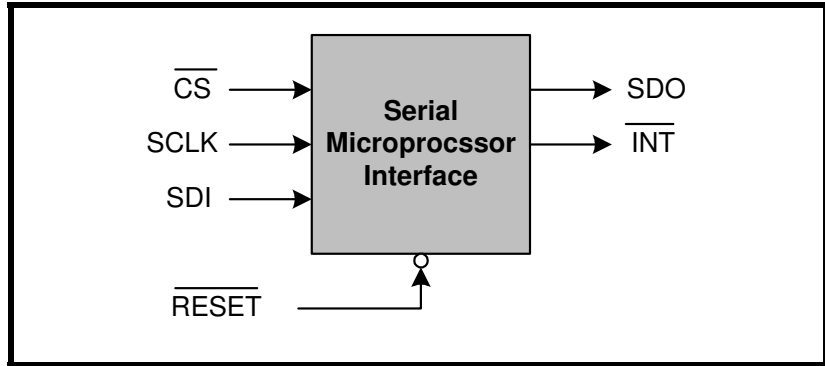

**FIGURE 21. MICROPROCESSOR SERIAL INTERFACE STRUCTURE**

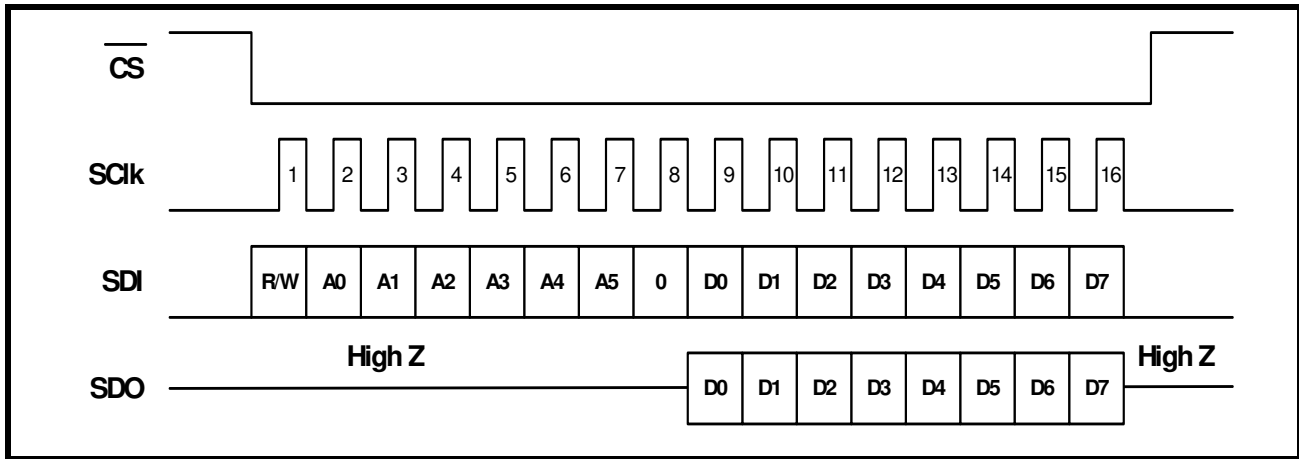

**NOTE:** If the R/W bit is set to "1", then this denotes a "READ" operation with the Microprocessor Serial Interface. Conversely, if the R/W bit is set to "0", then this denotes a "WRITE" operation.

FIGURE 22. TIMING DIAGRAM FOR THE MICROPROCESSOR SERIAL INTERFACE

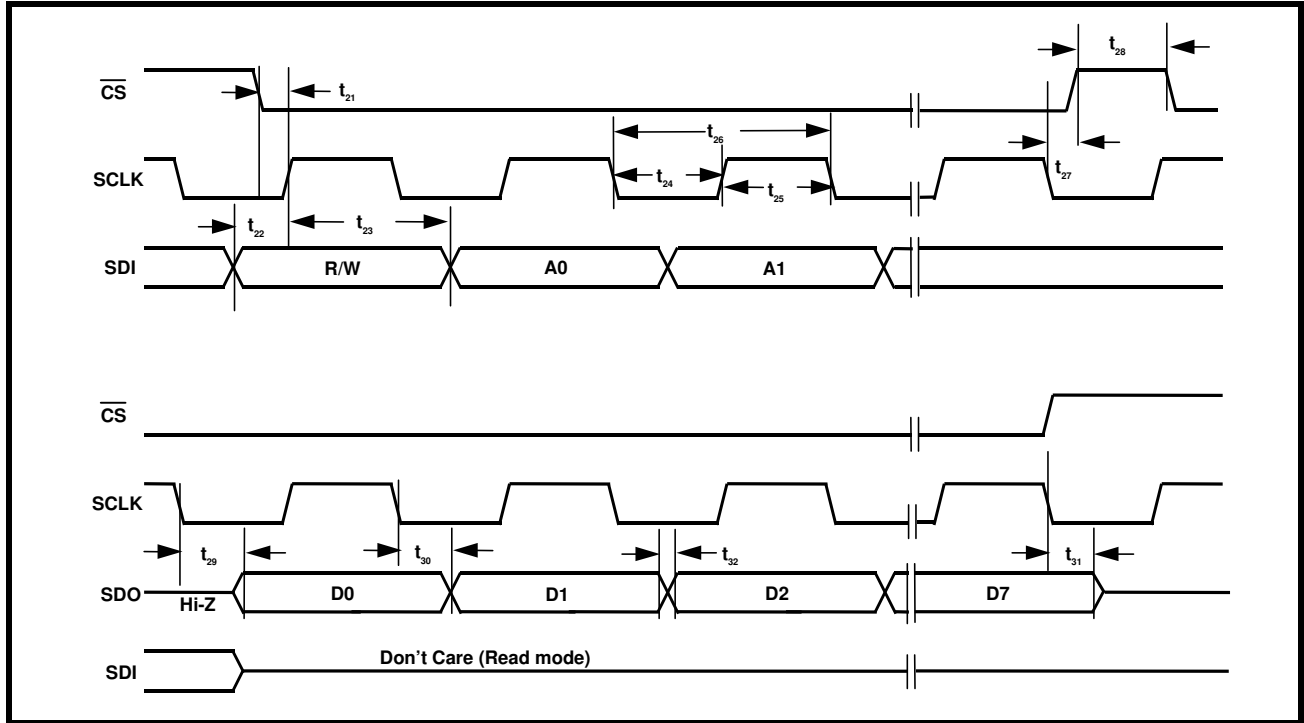

TABLE 5: MICROPROCESSOR SERIAL INTERFACE TIMINGS (  $T_A = 25^{\circ}\text{C}$ ,  $V_{DD}=3.3\text{V}\pm 5\%$  AND LOAD = 10PF)

SYMBOL	PARAMETER	MIN.	TYP.	MAX	UNITS
$t_{21}$	$\overline{\text{CS}}$ Low to Rising Edge of SClk	5			ns
$t_{22}$	SDI to Rising Edge of SClk	5			ns
$t_{23}$	SDI to Rising Edge of SClk Hold Time	5			ns
$t_{24}$	SClk "Low" Time	50			ns
$t_{25}$	SClk "High" Time	50			ns
$t_{26}$	SClk Period	100			ns
$t_{27}$	Falling Edge of SClk to rising edge of $\overline{\text{CS}}$	0			ns
$t_{28}$	$\overline{\text{CS}}$ Inactive Time	50			ns
$t_{29}$	Falling Edge of SClk to SDO Valid Time			20	ns
$t_{30}$	Falling Edge of SClk to SDO Invalid Time			10	ns
$t_{31}$	Rising edge of $\overline{\text{CS}}$ to High Z			25	ns
$t_{32}$	Rise/Fall time of SDO Output			5	ns

TABLE 6: MICROPROCESSOR REGISTER DESCRIPTION

REG	ADDR	TYPE	D7	D6	D5	D4	D3	D2	D1	D0
<b>Global Control Register for All 16 Channels (0x00h)</b>										
0	0x00	R/W	GIE	Reserved	SR/DR	CODE	FIFO	JABW	JASEL1	JASEL0
1	0x01	RO	INTS7	INTS6	INTS5	INTS4	INTS3	INTS2	INTS1	INTS0
2	0x02	RO	INTS15	INTS14	INTS13	INTS12	INTS11	INTS10	INTS9	INTS8
3	0x03	RO	<b>Revision ID (See Bit Description)</b>							
4	0x04	RO	<b>Device ID (See Bit Description)</b>							
5	0x05	RO	<b>Device ID (See Bit Description)</b>							
<b>Channel 0 Control Register (0x04h - 0x06h)</b>										
6	0x06	R/W	SRES_0 *	ARAOS_0	ATAOS_0	TAOS_0	RLAM_0	TXOE_0	RCLKinv_0	TCLKinv_0
7	0x07	R/W	Reserved	AISIE_0	DMOIE_0	RLOSIE_0	Reserved	Reserved	LPB1	LPB0
8	0x08	RUR/ RO	Reserved	AISIS_0	DMOIS_0	RLOSIS_0	Reserved	AISS_0	DMOS_0	RLOSS_0
<b>Channel 1 Control Register (0x07h - 0x09h)</b>										
9	0x09	R/W	SRES_1 *	ARAOS_1	ATAOS_1	TAOS_1	RLAM_1	TXOE_1	RCLKinv_1	TCLKinv_1
10	0x0A	R/W	Reserved	AISIE_1	DMOIE_1	RLOSIE_1	Reserved	Reserved	LPB1	LPB0
11	0x0B	RUR/ RO	Reserved	AISIS_1	DMOIS_1	RLOSIS_1	Reserved	AISS_1	DMOS_1	RLOSS_1
<b>Channel 2 Control Register (0x0Ah - 0x0Ch)</b>										
12	0x0C	R/W	SRES_2 *	ARAOS_2	ATAOS_2	TAOS_2	RLAM_2	TXOE_2	RCLKinv_2	TCLKinv_2
13	0x0D	R/W	Reserved	AISIE_2	DMOIE_2	RLOSIE_2	Reserved	Reserved	LPB1	LPB0
14	0x0E	RUR/ RO	Reserved	AISIS_2	DMOIS_2	RLOSIS_2	Reserved	AISS_2	DMOS_2	RLOSS_2
<b>Channel 3 Control Register (0x0Dh - 0x0Fh)</b>										
15	0x0F	R/W	SRES_3 *	ARAOS_3	ATAOS_3	TAOS_3	RLAM_3	TXOE_3	RCLKinv_3	TCLKinv_3
16	0x10	R/W	Reserved	AISIE_3	DMOIE_3	RLOSIE_3	Reserved	Reserved	LPB1	LPB0
17	0x11	RUR/ RO	Reserved	AISIS_3	DMOIS_3	RLOSIS_3	Reserved	AISS_3	DMOS_3	RLOSS_3
<b>Channel 4 Control Register (0x10h - 0x12h)</b>										
18	0x12	R/W	SRES_4 *	ARAOS_4	ATAOS_4	TAOS_4	RLAM_4	TXOE_4	RCLKinv_4	TCLKinv_4
19	0x13	R/W	Reserved	AISIE_4	DMOIE_4	RLOSIE_4	Reserved	Reserved	LPB1	LPB0
20	0x14	RUR/ RO	Reserved	AISIS_4	DMOIS_4	RLOSIS_4	Reserved	AISS_4	DMOS_4	RLOSS_4
<b>Channel 5 Control Register (0x13h - 0x15h)</b>										
21	0x15	R/W	SRES_5 *	ARAOS_5	ATAOS_5	TAOS_5	RLAM_5	TXOE_5	RCLKinv_5	TCLKinv_5
22	0x16	R/W	Reserved	AISIE_5	DMOIE_5	RLOSIE_5	Reserved	Reserved	LPB1	LPB0
23	0x17	RUR/ RO	Reserved	AISIS_5	DMOIS_5	RLOSIS_5	Reserved	AISS_5	DMOS_5	RLOSS_5
<b>Channel 6 Control Register (0x16h - 0x18h)</b>										

**TABLE 6: MICROPROCESSOR REGISTER DESCRIPTION**

REG	ADDR	TYPE	D7	D6	D5	D4	D3	D2	D1	D0
24	0x18	R/W	SRES_6 *	ARAOS_6	ATAOS_6	TAOS_6	RLAM_6	TXOE_6	RCLKinv_6	TCLKinv_6
25	0x19	R/W	Reserved	AISIE_6	DMOIE_6	RLOSIE_6	Reserved	Reserved	LPB1	LPB0
26	0x1A	RUR/ RO	Reserved	AISIS_6	DMOIS_6	RLOIS_6	Reserved	AISS_6	DMOS_6	RLOSS_6
<b>Channel 7 Control Register (0x19h - 0x1Bh)</b>										
27	0x1B	R/W	SRES_7 *	ARAOS_7	ATAOS_7	TAOS_7	RLAM_7	TXOE_7	RCLKinv_7	TCLKinv_7
28	0x1C	R/W	Reserved	AISIE_7	DMOIE_7	RLOSIE_7	Reserved	Reserved	LPB1	LPB0
29	0x1D	RUR/ RO	Reserved	AISIS_7	DMOIS_7	RLOIS_7	Reserved	AISS_7	DMOS_7	RLOSS_7
<b>Channel 8 Control Register (0x1Ch - 0x1Eh)</b>										
30	0x1E	R/W	SRES_8 *	ARAOS_8	ATAOS_8	TAOS_8	RLAM_8	TXOE_8	RCLKinv_8	TCLKinv_8
31	0x1F	R/W	Reserved	AISIE_8	DMOIE_8	RLOSIE_8	Reserved	Reserved	LPB1	LPB0
32	0x20	RUR/ RO	Reserved	AISIS_8	DMOIS_8	RLOIS_8	Reserved	AISS_8	DMOS_8	RLOSS_8
<b>Channel 9 Control Register (0x1Fh - 0x21h)</b>										
33	0x21	R/W	SRES_9 *	ARAOS_9	ATAOS_9	TAOS_9	RLAM_9	TXOE_9	RCLKinv_9	TCLKinv_9
34	0x22	R/W	Reserved	AISIE_9	DMOIE_9	RLOSIE_9	Reserved	Reserved	LPB1	LPB0
35	0x23	RUR/ RO	Reserved	AISIS_9	DMOIS_9	RLOIS_9	Reserved	AISS_9	DMOS_9	RLOSS_9
<b>Channel 10 Control Register (0x22h - 0x24h)</b>										
36	0x24	R/W	SRES_10 *	ARAOS_10	ATAOS_10	TAOS_10	RLAM_10	TXOE_10	RCLKinv_10	TCLKinv_10
37	0x25	R/W	Reserved	AISIE_10	DMOIE_10	RLOSIE_10	Reserved	Reserved	LPB1	LPB0
38	0x26	RUR/ RO	Reserved	AISIS_10	DMOIS_10	RLOIS_10	Reserved	AISS_10	DMOS_10	RLOSS_10
<b>Channel 11 Control Register (0x25h - 0x27h)</b>										
39	0x27	R/W	SRES_11 *	ARAOS_11	ATAOS_11	TAOS_11	RLAM_11	TXOE_11	RCLKinv_11	TCLKinv_11
40	0x28	R/W	Reserved	AISIE_11	DMOIE_11	RLOSIE_11	Reserved	Reserved	LPB1	LPB0
41	0x29	RUR/ RO	Reserved	AISIS_11	DMOIS_11	RLOIS_11	Reserved	AISS_11	DMOS_11	RLOSS_11
<b>Channel 12 Control Register (0x28h - 0x2Ah)</b>										
42	0x2A	R/W	SRES_12 *	ARAOS_12	ATAOS_12	TAOS_12	RLAM_12	TXOE_12	RCLKinv_12	TCLKinv_12
43	0x2B	R/W	Reserved	AISIE_12	DMOIE_12	RLOSIE_12	Reserved	Reserved	LPB1	LPB0
44	0x2C	RUR/ RO	Reserved	AISIS_12	DMOIS_12	RLOIS_12	Reserved	AISS_12	DMOS_12	RLOSS_12
<b>Channel 13 Control Register (0x2Bh - 0x2Dh)</b>										
45	0x2D	R/W	SRES_13 *	ARAOS_13	ATAOS_13	TAOS_13	RLAM_13	TXOE_13	RCLKinv_13	TCLKinv_13
46	0x2E	R/W	Reserved	AISIE_13	DMOIE_13	RLOSIE_13	Reserved	Reserved	LPB1	LPB0
47	0x2F	RUR/ RO	Reserved	AISIS_13	DMOIS_13	RLOIS_13	Reserved	AISS_13	DMOS_13	RLOSS_13

TABLE 6: MICROPROCESSOR REGISTER DESCRIPTION

REG	ADDR	TYPE	D7	D6	D5	D4	D3	D2	D1	D0
<b>Channel 14 Control Register (0x2Eh - 0x30h)</b>										
48	0x30	R/W	SRES_14 *	ARAOS_14	ATAOS_14	TAOS_14	RLAM_14	TXOE_14	RCLKinv_14	TCLKinv_14
49	0x31	R/W	Reserved	AISIE_14	DMOIE_14	RLOSIE_14	Reserved	Reserved	LPB1	LPB0
50	0x32	RUR/ RO	Reserved	AISIS_14	DMOIS_14	RLOSIS_14	Reserved	AISS_14	DMOS_14	RLOSS_14
<b>Channel 15 Control Register (0x31h - 0x33h)</b>										
51	0x33	R/W	SRES_15 *	ARAOS_15	ATAOS_15	TAOS_15	RLAM_15	TXOE_15	RCLKinv_15	TCLKinv_15
52	0x34	R/W	Reserved	AISIE_15	DMOIE_15	RLOSIE_15	Reserved	Reserved	LPB1	LPB0
53	0x35	RUR/ RO	Reserved	AISIS_15	DMOIS_15	RLOSIS_15	Reserved	AISS_15	DMOS_15	RLOSS_15

**NOTE:** \* Indicates that these bits are WRITE-ONLY Reset for that channel register only.

TABLE 7: MICROPROCESSOR REGISTER 0X00H BIT DESCRIPTION

GLOBAL CONTROL REGISTER FOR ALL 16 CHANNELS (0x00H)				
BIT	NAME	FUNCTION	Register Type	Default Value (HW reset)
D7	GIE	<b>Global Interrupt Enable</b> The global interrupt enable is used to enable/disable all interrupt activity for all 16 channels. This bit must be set "High" for the interrupt pin to operate.  "0" = Disable all interrupt generation "1" = Enable interrupt generation to the individual channel registers	R/W	0
D6	Reserved	This Register Bit is Not Used	R/W	0
D5	SR/DR	<b>Single Rail / Dual Rail Select</b> This bit is used to configure the receive outputs and transmit inputs to single rail or dual rail data formats.  "0" = Dual Rail "1" = Single Rail	R/W	0
D4	CODE	<b>Encoding / Decoding Select (Single Rail Mode Only)</b> This bit is used to select between AMI or HDB3.  "0" = HDB3 "1" = AMI	R/W	0
D3	FIFOS	<b>FIFO Depth Select</b> The FIFO depth select is used to configure the part for a 32-bit or 64-bit FIFO (Within the Jitter Attenuator Block). The delay of the FIFO is typically equal to ½ the FIFO depth.  "0" = 32-bit FIFO "1" = 64-bit FIFO	R/W	0



TABLE 7: MICROPROCESSOR REGISTER 0x00H BIT DESCRIPTION

GLOBAL CONTROL REGISTER FOR ALL 16 CHANNELS (0x00H)				
BIT	NAME	FUNCTION	Register Type	Default Value (HW reset)
D2	JABW	<p><b>JA Band width Select</b> This bit is used to select the band with of the JA PLL.</p> <p>"0" = 10 Hz "1" = 1.5Hz</p> <p><i>NOTE: If a "1" is written into this bit, JA FIFO size of 64 bit wide is automatically selected.</i></p>	R/W	0
D1 D0	JASEL1 JASEL0	<p><b>Jitter Attenuator Select</b> These bits are used to configure the Jitter Attenuator into the Receive or Transmit path.</p> <p>"00" = Disabled "01" = Transmit Path "10" = Receive Path "11" = Disabled</p>	R/W	0 0

TABLE 8: MICROPROCESSOR REGISTERS 0x01H & 0x02H BIT DESCRIPTION

INTERRUPT STATUS REGISTERS (0x01H) & 0x02H				
BIT	NAME	FUNCTION	Register Type	Default Value (HW reset)
D7 D6 D5 D4 D3 D2 D1 D0	INTS_n	<p><b>Interrupt Status</b> These 2 registers are ready only to determine when an interrupt event occurs, the channel that generates interrupt can be identified with minimum read/write operation.</p>	RO	0 0 0 0 0 0 0 0

TABLE 9: MICROPROCESSOR REGISTER 0x03H BIT DESCRIPTION

REVISION "ID" REGISTER (0x03H)				
BIT	NAME	FUNCTION	Register Type	Default Value (HW reset)
D7 D6 D5 D4 D3 D2 D1 D0	Revision "ID"	The revision "ID" of the XRT83SL216 LIU is used to enable software to identify which revision of silicon is currently being tested. The revision "ID" for the first revision of silicon (Revision A) will be 0x01h.	RO	0 0 0 0 0 0 0 1

TABLE 10: MICROPROCESSOR REGISTERS 0x04H & 0x05H BIT DESCRIPTION

DEVICE "ID" REGISTERS (0x04H & 0x05H)				
BIT	NAME	FUNCTION	Register Type	Default Value (HW reset)
D7 D6 D5 D4 D3 D2 D1 D0	Device "ID"	The device for this chip consists of 2 read only registers. The ID for the XR T83SL216 is 0x8004h.	RO	

TABLE 11: MICROPROCESSOR REGISTER BIT DESCRIPTION

CHANNEL CONTROL REGISTER (CHANNEL_n, where n = 0:15) (0x06H, 0x09H, 0x0CH, 0x0FH, 0x12H, 0x15H, 0x18H, 0x1BH, 1EH, 0x21H, 0x24H, 0x27H, 0x2AH, 0x2DH, 0x30H, 0x33H)				
BIT	NAME	FUNCTION	Register Type	Default Value (HW reset)
D7	SRES_n	<b>Software Reset</b> Writing a "1" to this bit will cause the channel register to reset to it's default value. <i>NOTE: This is a Write-Only bit.</i>	WO	X
D6	ARAOS_n	<b>Automatic Receive All Ones</b> If ARAOS_n is selected, an all ones pattern will be sent to the RPOS/RNEG outputs if the channel experiences an RLOS condition. If RLOS does not occur, ARAOS_n will remain inactive.  "0" = Disabled "1" = Enabled	R/W	0

TABLE 11: MICROPROCESSOR REGISTER BIT DESCRIPTION

CHANNEL CONTROL REGISTER (CHANNEL_n, where n = 0:15) (0x06H, 0x09H, 0x0CH, 0x0FH, 0x12H, 0x15H, 0x18H, 0x1BH, 1EH, 0x21H, 0x24H, 0x27H, 0x2AH, 0x2DH, 0x30H, 0x33H)				
BIT	NAME	FUNCTION	Register Type	Default Value (HW reset)
D5	ATAOS_n	<b>Automatic Transmit All Ones</b> If ATAOS_n is selected, an all ones pattern will be transmitted from TTIP/TRING if the channel experiences an RLOS condition. If RLOS does not occur, ATAOS_n will remain inactive.  "0" = Disabled "1" = Enabled	R/W	0
D4	TAOS_n	<b>Transmit All Ones</b> If TAOS_n is selected, an all ones pattern will be transmitted from TTIP/TRING if the transmitter is turned on. Remote Loop Back has priority over TAOS.  "0" = Disabled "1" = Enabled	R/W	0
D3	RLAM_n	<b>RLOS/AIS Mode Select for channel n</b> This bit is used to select the industry standard for declaring / clearing RLOS and AIS functionality. See the Receive section of the Line Interface description.  "0" = ITU G.775 "1" =ETSI300233	R/W	0
D2	TXOE_n	<b>Transmit Output Enable</b> Upon power up, the transmitters are tri-stated. This bit is used to enable the transmitter for this channel if the TxOE pin is pulled "High". If the TxOE pin is pulled "Low", all 8 transmitters are tri-stated.  "0" = Transmitter is disabled "1" = Transmitter is enabled if TxOE pin is pulled "High"	R/W	0
D1	RCLKinv_n	<b>Receiver Clock Invert</b> This bit is used to invert receive clock update edge with respect to RPOS/RNEG output data.  "0" =RPOS/RNEG data is updated on the rising edge of RCLK "1" =RPOS/RNEG data is updated on the falling edge of RCLK.	R/W	0 0
D0	TCLKinv_n	<b>Transmit Clock Invert</b> This bit is used to invert transmit clock sampling edge with respect to TPOS/TNEG input data.  "0" =TPOS/TNEG data is sampled on the falling edge of TCLK "1" =TPOS/TNEG data is sampled on the rising edge of TCLK.	R/W	0

TABLE 12: MICROPROCESSOR REGISTER BIT DESCRIPTION

CHANNEL CONTROL REGISTER (CHANNEL_n, where n = 0:15) (0x07H, 0x0AH, 0x0DH, 0x10H, 0x13H, 0x16H, 0x19H, 0x1CH, 0x1FH, 0x22H, 0x25H, 0x28H, 0x2BH, 0x2EH, 0x31H, 0x34H)																			
BIT	NAME	FUNCTION	Register Type	Default Value (HW reset)															
D7	Reserved	This Register Bit is Not Used	X	X															
D6	AISIE_n	<b>Alarm Indication Signal Interrupt Enable</b> "0" = Masks the AIS interrupt generation "1" = Enables Interrupt generation	R/W	0															
D5	DMOIE_n	<b>Driver Monitor Output Interrupt Enable</b> "0" = Masks the DMO interrupt generation "1" = Enables Interrupt generation	R/W	0															
D4	RLOSIE_n	<b>Receiver Loss of Signal Interrupt Enable</b> "0" = Masks the RLOS interrupt generation "1" = Enables Interrupt generation	R/W	0															
D3	Reserved	This Register Bit is Not Used	X	X															
D2	Reserved	This Register Bit is Not Used	X	X															
D1 D0	LPB1 LPB0	<b>Loop Back Select</b> These bits are used to configure the channel in one of three loop-back modes. For additional information on loopback modes, see the Application Section of this datasheet. <table border="1" data-bbox="441 1129 873 1367"> <thead> <tr> <th>LPB1</th> <th>LPB0</th> <th>Loopback Mode</th> </tr> </thead> <tbody> <tr> <td>0</td> <td>0</td> <td>No Loopback</td> </tr> <tr> <td>0</td> <td>1</td> <td>Analog Loopback</td> </tr> <tr> <td>1</td> <td>0</td> <td>Remote Loopback</td> </tr> <tr> <td>1</td> <td>1</td> <td>Digital Loopback</td> </tr> </tbody> </table>	LPB1	LPB0	Loopback Mode	0	0	No Loopback	0	1	Analog Loopback	1	0	Remote Loopback	1	1	Digital Loopback	R/W	0
LPB1	LPB0	Loopback Mode																	
0	0	No Loopback																	
0	1	Analog Loopback																	
1	0	Remote Loopback																	
1	1	Digital Loopback																	

TABLE 13: MICROPROCESSOR REGISTER BIT DESCRIPTION

CHANNEL CONTROL REGISTER (CHANNEL_n, where n = 0:15) (0x08H, 0x0BH, 0x0EH, 0x11H, 0x14H, 0x17H, 0x1AH, 0x1DH, 0x20H, 0x23H, 0x26H, 0x29H, 0x2CH, 0x2FH, 0x32H, 0x35H)				
BIT	NAME	FUNCTION	Register Type	Default Value (HW reset)
D7	Reserved	This Register Bit is Not Used	R/W	X
D6	AISIS_n	<b>Alarm Indication Signal Interrupt Status</b> "0" = No Change "1" = Change in Status Occured	RUR	0

TABLE 13: MICROPROCESSOR REGISTER BIT DESCRIPTION

CHANNEL CONTROL REGISTER (CHANNEL_n, where n = 0:15) (0x08H, 0x0BH, 0x0EH, 0x11H, 0x14H, 0x17H, 0x1AH, 0x1DH, 0x20H, 0x23H, 0x26H, 0x29H, 0x2CH, 0x2FH, 0x32H, 0x35H)				
BIT	NAME	FUNCTION	Register Type	Default Value (HW reset)
D5	DMOIS_n	<b>Driver Monitor Output Interrupt Status</b> "0" = No Change "1" = Change in Status Occured	RUR	0
D4	RLOSSI_n	<b>Receiver Loss of Signal Interrupt Status</b> "0" = No Change "1" = Change in Status Occured	RUR	0
D3	Reserved	This Register Bit is Not Used	R/W	X
D2	AISS_n	<b>AIS Alarm Status</b> This alarm indication signal detection is always active regardless if the interrupt generation is disabled. This bit indicates the AIS activity at the time of reading.  "0" = No Alarm "1" = An All "Ones" Signal is detected.	RO	0
D1	DMOS_n	<b>Driver Monitor Output Status</b> The Driver Monitor output is always active regardless if the interrupt generation is disabled. This bit indicates the DMO output activity at the time of reading.  "0" = No alarm "1" = Failure at the transmit output is detected.	RO	0
D0	RLOSS_n	<b>Receive Loss of Signal Status</b> The receiver loss of signal detection is always active regardless if the interrupt generation is disabled. This bit indicates the RLOS activity at the time of reading.  "0" = No Alarm "1" = Loss of Signal condition is detected.	RO	0

## ELECTRICAL CHARACTERISTICS

TABLE 14: ABSOLUTE MAXIMUM RATINGS

Storage Temperature	-65°C to +150°C
Operating Temperature	-40°C to +85°C
Supply Voltage	-0.5V to +6.0V

TABLE 15: DC DIGITAL INPUT AND OUTPUT ELECTRICAL CHARACTERISTICS

VDD=3.3V ±5%, T <sub>A</sub> =25°C, UNLESS OTHERWISE SPECIFIED					
PARAMETER	SYMBOL	MIN	TYP	MAX	UNITS
Power Supply Voltage	VDD	3.13	3.3	3.46	V
Input High Voltage	V <sub>IH</sub>	2.0	-	5.0	V
Input Low Voltage	V <sub>IL</sub>	-0.5	-	0.8	V
Output High Voltage IOH=2.0mA	V <sub>OH</sub>	2.4	-		V
Output Low Voltage IOL=2.0mA	V <sub>OL</sub>	-	-	0.4	V
Input Leakage Current	I <sub>L</sub>	-	-	±10	µA
Input Capacitance	C <sub>I</sub>	-	5.0		pF
Output Lead Capacitance	C <sub>L</sub>	-	-	25	pF

NOTE: Input leakage current excludes pins that are internally pulled "Low" or "High".

TABLE 16: AC ELECTRICAL CHARACTERISTICS

VDD=3.3V ±5%, T <sub>A</sub> =25°C, UNLESS OTHERWISE SPECIFIED					
PARAMETER	SYMBOL	MIN	TYP	MAX	UNITS
MCLK Clock Duty Cycle		40	-	60	%
MCLK Clock Tolerance		-	±50	-	ppm

TABLE 17: POWER CONSUMPTION

VDD=3.3V ±5%, T <sub>A</sub> =25°C, UNLESS OTHERWISE SPECIFIED							
MODE	IMPEDANCE	RECEIVER	TRANSMITTER	TYP	MAX	UNIT	TEST CONDITION
E1	75Ω	2:1	1:2	1.6 2.3		W	50% ones 100% ones
E1	120Ω	2:1	1:2	1.4 1.9		W	50% ones 100% ones
E1	75Ω/120Ω	2:1	1:2	400		mW	Transmitter OFF

TABLE 18: RECEIVER ELECTRICAL CHARACTERISTICS

VDD=3.3V ±5%, T <sub>A</sub> =25°C, UNLESS OTHERWISE SPECIFIED					
PARAMETER	MIN	TYP	MAX	UNIT	TEST CONDITION
<b>Receiver Loss of Signal</b>					
Number of consecutive zeros before RLOS is declared	-	32	-		G.775
	-	2048	-		ETSI 300 233
Input signal level at RLOS	15	20	-	dB	Cable attenuation @ 1024kHz
RLOS clear	12.5	-	-	% ones	ITU-G.775, ETSI 300 233
<b>Receiver Sensitivity</b> (flat loss only)	11	13	-	dB	With nominal pulse amplitude of 3.0V for 120Ω and 2.37V for 75Ω. With -18dB interference signal added.
<b>Interference Margin</b>	-18	-14			With 6dB cable loss.
<b>Input Impedance</b>	-	15	-	kΩ	
<b>Input Jitter Tolerance</b>					
1Hz	37	-	-	U <sub>I</sub> <sub>p-p</sub>	ITU-G.823
10kHz - 100kHz	0.2	-	-	U <sub>I</sub> <sub>p-p</sub>	
<b>Recovered Clock Jitter</b>					
Transfer Corner Frequency	-	36	-	kHz	
Peaking Amplitude	-	-	+0.5	dB	
<b>Jitter Attenuator Corner Frequency</b>					
JABW = "0"	-	10	-	Hz	
JABW = "1"	-	1.5	-	Hz	
<b>Return Loss</b>					
51kHz - 102kHz	14	-	-	dB	ITU-G.703
102kHz - 2048kHz	20	-	-	dB	
2048kHz - 3072kHz	16	-	-	dB	

TABLE 19: E1 TRANSMITTER ELECTRICAL CHARACTERISTICS

VDD=3.3V ±5%, T <sub>A</sub> =25°C, UNLESS OTHERWISE SPECIFIED					
PARAMETER	MIN	TYP	MAX	UNIT	TEST CONDITION
<b>AMI Output Pulse Amplitude</b>					
75Ω	2.13	2.37	2.60	V	1:2 Transformer
120Ω	2.70	3.00	3.30	V	
<b>Output Pulse Width</b>	224	244	264	ns	
<b>Output Pulse Width Ratio</b>	0.95	-	1.05		ITU-G.703
<b>Output Pulse Amplitude Ratio</b>	0.95	-	1.05		ITU-G.703
<b>Jitter Added by the Transmitter Output</b>	-	0.025	0.05	U <sub>Ipp</sub>	Broad Band with jitter free TCLK applied to the input.
<b>Output Return Loss</b>					
51kHz - 102kHz	12	-	-	dB	ETSI 300 166
102kHz - 2048kHz	10	-	-	dB	
2048kHz - 3072kHz	8	-	-	dB	

**NOTE:** Transmit output return loss is dependent on the transformer characteristics.



**ORDERING INFORMATION**

PRODUCT NUMBER	PACKAGE	OPERATING TEMPERATURE RANGE
XRT83SL216IB	289 ball STBGA	-40°C to +85°C

**PACKAGE DIMENSIONS**

**FIGURE 23. 15X15MM 289 BALL STBGA**

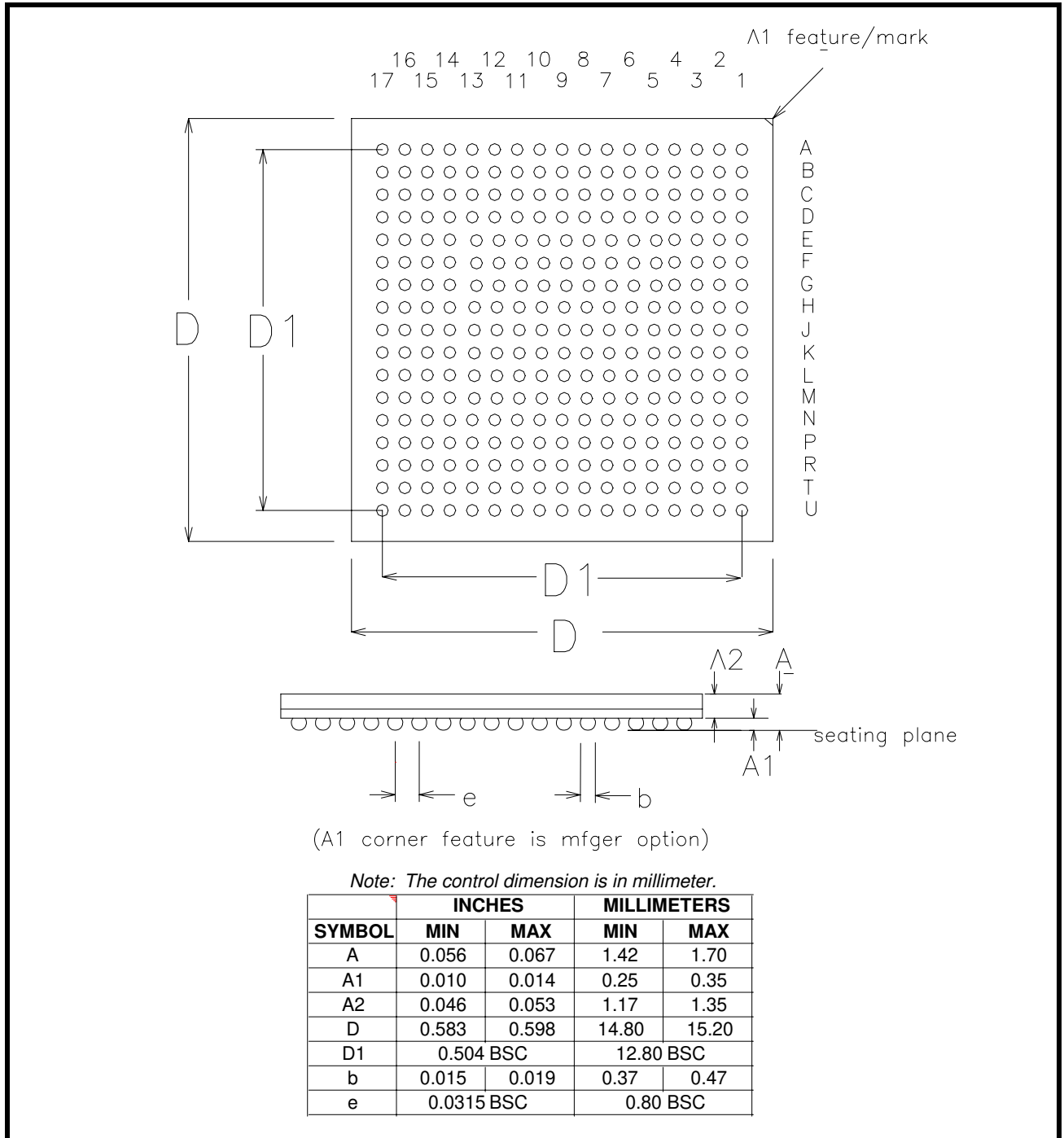

**REVISION HISTORY**

REVISION #	DATE	DESCRIPTION
P1.0.0	07/07/05	First release of the 16-Channel LIU Preliminary Datasheet
P1.0.1	08/04/05	Edits to features, RNEG description, figure 6,, electrical supply voltage.
P1.0.2	11/05	Edits
P1.0.3	12/06/05	Changed receive transformer turns ratio from 1:1 to 2:1. Added register information. Table 16: Power Consumption added TYP values.
1.0.0	08/02/06	Removed TBD's from electrical, removed preliminary and updated document format. Added timing diagram and timing info for the microprocessor serial interface.

**NOTICE**

EXAR Corporation reserves the right to make changes to the products contained in this publication in order to improve design, performance or reliability. EXAR Corporation assumes no responsibility for the use of any circuits described herein, conveys no license under any patent or other right, and makes no representation that the circuits are free of patent infringement. Charts and schedules contained here in are only for illustration purposes and may vary depending upon a user's specific application. While the information in this publication has been carefully checked; no responsibility, however, is assumed for inaccuracies.

EXAR Corporation does not recommend the use of any of its products in life support applications where the failure or malfunction of the product can reasonably be expected to cause failure of the life support system or to significantly affect its safety or effectiveness. Products are not authorized for use in such applications unless EXAR Corporation receives, in writing, assurances to its satisfaction that: (a) the risk of injury or damage has been minimized; (b) the user assumes all such risks; (c) potential liability of EXAR Corporation is adequately protected under the circumstances.

Copyright 2006 EXAR Corporation

Datasheet August 2006.

Reproduction, in part or whole, without the prior written consent of EXAR Corporation is prohibited.