

## Description

The 74LVC2G06 is a dual inverter gate with open drain outputs. The device is designed for operation with a power supply range of 1.65V to 5.5V. The input is tolerant to 5.5V allowing this device to be used in a mixed voltage environment. The device is fully specified for partial power down applications using  $I_{OFF}$ . The  $I_{OFF}$  circuitry disables the output preventing damaging current backflow when the device is powered down. The open-drain output can be connected to other open drain outputs to implement active-low wired-OR or active-high wired-AND functions. The maximum sink current is 32mA.

## Features

- Wide Supply Voltage Range from 1.65V to 5.5V
- -24mA Output Drive at 3.0V
- CMOS Low Power Consumption
- IOFF Supports Partial-Power-Down Mode Operation
- Inputs Accept up to 5.5V
- ESD Protection Tested per JESD 22
  - Exceeds 200-V Machine Model (A115)
  - Exceeds 2000-V Human Body Model (A114)
  - Exceeds 1000-V Charged Device Model (C101)
- Latch-Up Exceeds 100mA per JESD 78, Class I
- DFN1409 package designed as a direct replacement for chip scale packaging.
- Range of Package Options SOT26, SOT363, X1-DFN1010-6, X2-DFN1010-6, X2-DFN1409-6, and X2-DFN1410-6
- Leadless Packages Named per JESD30E
- **Totally Lead-Free & Fully RoHS Compliant (Notes 1 & 2)**
- **Halogen and Antimony Free. "Green" Device (Note 3)**

## Pin Assignments

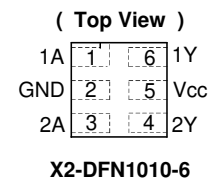
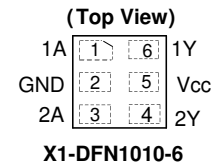
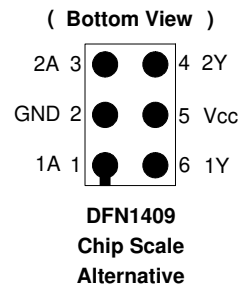
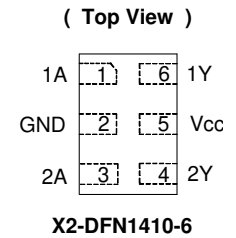
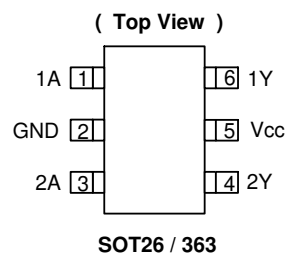

## Applications

- Voltage Level Shifting
- General Purpose Logic
- Power Down Signal Isolation
- Wide array of products such as:
  - PCs, Networking, Notebooks, Netbooks, Tablets
  - Computer Peripherals, Hard Drives, SSD, CD/DVD ROM
  - TV, DVD, DVR, Set-Top Box
  - Cell Phones, Personal Navigation / GPS
  - MP3 Players, Cameras, Video Recorders

Notes: 1. No purposely added lead. Fully EU Directive 2002/95/EC (RoHS) & 2011/65/EU (RoHS 2) compliant.  
 2. See [http://www.diodes.com/quality/lead\\_free.html](http://www.diodes.com/quality/lead_free.html) for more information about Diodes Incorporated's definitions of Halogen- and Antimony-free, "Green" and Lead-free.  
 3. Halogen- and Antimony-free "Green" products are defined as those which contain <900ppm bromine, <900ppm chlorine (<1500ppm total Br + Cl) and <1000ppm antimony compounds.

## Ordering Information

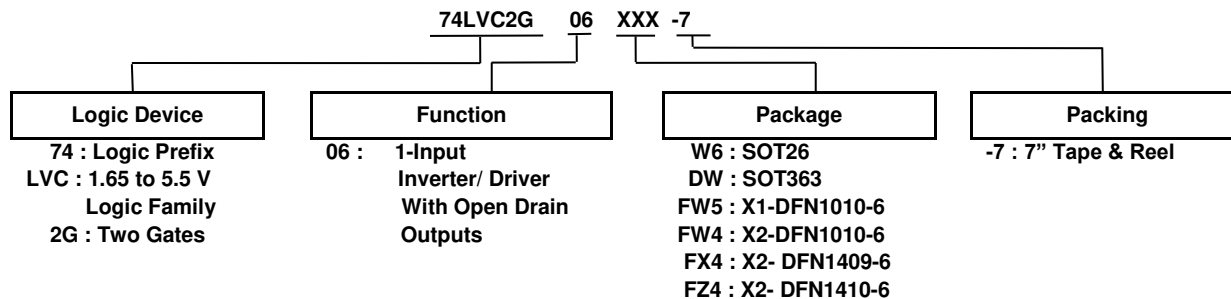

Device	Package Code	Package (Note 4)	Package Size	7" Tape and Reel (Note 5)	
				Quantity	Part Number Suffix
74LVC2G06W6-7	W6	SOT26	2.8mm X 2.2 mm X 1.1mm 0.95 mm lead pitch	3,000/Tape & Reel	-7
74LVC2G06DW-7	DW	SOT363	2.0mm X 2.0mm X 1.1mm 0.65 mm lead pitch	3,000/Tape & Reel	-7
74LVC2G06FW5-7	FW5	X1-DFN1010-6	1.0mm X 1.0mm X 0.5mm 0.35 mm pad pitch	5,000/Tape & Reel	-7
74LVC2G06FW4-7	FW4	X2-DFN1010-6	1.0mm X 1.0mm X 0.4mm 0.35 mm pad pitch	5,000/Tape & Reel	-7
74LVC2G06FX4-7	FX4	X2-DFN1409-6 Chip Scale Alternative	1.4mm X 0.9mm X 0.4mm 0.5 mm pad pitch	5,000/Tape & Reel	-7
74LVC2G06FZ4-7	FZ4	X2-DFN1410-6	1.4mm X 1.0mm X 0.4mm 0.5 mm pad pitch	5,000/Tape & Reel	-7

Notes: 4. Pad layout as shown on Diodes Inc. suggested pad layout document AP02001, which can be found on our website at <http://www.diodes.com/datasheets/ap02001.pdf>.  
 5. The taping orientation is located on our website at <http://www.diodes.com/datasheets/ap02007.pdf>.

## Pin Descriptions

Pin Name	Pin.	Function
1A	1	Data Input
GND	2	Ground
2A	3	Data Input
2Y	4	Data Output Open Drain
V <sub>CC</sub>	5	Supply Voltage
1Y	6	Data Output Open Drain

## Logic Diagram

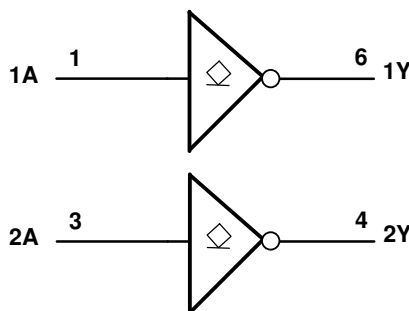

## Function Table

Inputs	Output
A	Y
H	L
L	Z

**Absolute Maximum Ratings** (Notes 6 & 7) (@ $T_A = +25^\circ\text{C}$ , unless otherwise specified.)

Symbol	Description	Rating	Unit
ESD HBM	Human Body Model ESD Protection	2	kV
ESD CDM	Charged Device Model ESD Protection	1	kV
ESD MM	Machine Model ESD Protection	200	V
$V_{CC}$	Supply Voltage Range	-0.5 to +6.5	V
$V_I$	Input Voltage Range	-0.5 to +6.5	V
$V_O$	Voltage Applied to Output in High Impedance or $I_{OFF}$ State	-0.5 to +6.5	V
$V_O$	Voltage Applied to Output in High or Low State	-0.3 to $V_{CC} + 0.5$	V
$I_{IK}$	Input Clamp Current $V_I < 0$	-50	mA
$I_{OK}$	Output Clamp Current $V_O < 0$	-50	mA
$I_O$	Continuous Output Current	-50	mA
	Continuous Current Through $V_{DD}$ or GND	$\pm 100$	mA
$T_J$	Operating Junction Temperature	-40 to +150	$^\circ\text{C}$
$T_{STG}$	Storage Temperature	-65 to +150	$^\circ\text{C}$

- Note 6. Stresses beyond the absolute maximum may result in immediate failure or reduced reliability. These are stress values and device operation should be within recommend values.
- Note 7. Forcing the maximum allowed voltage could cause a condition exceeding the maximum current or conversely forcing the maximum current could cause a condition exceeding the maximum voltage. The ratings of both current and voltage must be maintained within the controlled range.

**Recommended Operating Conditions** (Note 8) (@ $T_A = +25^\circ\text{C}$ , unless otherwise specified.)

Symbol	Parameter	Min	Max	Unit	
$V_{CC}$	Operating Voltage	Operating	1.65	5.5	V
		Data Retention Only	1.5	—	V
$V_{IH}$	High-Level Input Voltage	$V_{CC} = 1.65\text{V to }1.95\text{V}$	$0.65 \times V_{CC}$	—	V
		$V_{CC} = 2.3\text{V to }2.7\text{V}$	1.7	—	
		$V_{CC} = 3\text{V to }3.6\text{V}$	2	—	
		$V_{CC} = 4.5\text{V to }5.5\text{V}$	$0.7 \times V_{CC}$	—	
$V_{IL}$	Low-Level Input Voltage	$V_{CC} = 1.65\text{V to }1.95\text{V}$	—	$0.35 \times V_{CC}$	V
		$V_{CC} = 2.3\text{V to }2.7\text{V}$	—	0.7	
		$V_{CC} = 3\text{V to }3.6\text{V}$	—	0.8	
		$V_{CC} = 4.5\text{V to }5.5\text{V}$	—	$0.3 \times V_{CC}$	
$V_I$	Input Voltage	0	5.5	V	
$V_O$	Output Voltage	0	$V_{CC}$	V	
$I_{OL}$	Low-Level Output Current	$V_{CC} = 1.65\text{V}$	—	4	mA
		$V_{CC} = 2.3\text{V}$	—	8	
		$V_{CC} = 3\text{V}$	—	16	
		$V_{CC} = 4.5\text{V}$	—	24	
$\Delta t/\Delta V$	Input Transition Rise or Fall Rate	$V_{CC} = 1.8\text{V} \pm 0.15\text{V}, 2.5\text{V} \pm 0.2\text{V}$	—	20	ns/V
		$V_{CC} = 3.3\text{V} \pm 0.3\text{V}$	—	10	
		$V_{CC} = 5\text{V} \pm 0.5\text{V}$	—	10	
$T_A$	Operating Free-Air Temperature	-40	+125	$^\circ\text{C}$	

Note: 8. Unused inputs should be held at  $V_{CC}$  or Ground.

### Electrical Characteristics

Symbol	Parameter	Test Conditions	V <sub>CC</sub>	-40°C to +85°C		-40°C to +125°C		Unit
				Min	Max	Min	Max	
V <sub>OL</sub>	Low-Level Output Voltage	I <sub>OL</sub> = 100µA	1.65V to 5.5V	—	0.1	—	0.1	V
		I <sub>OL</sub> = 4mA	1.65V	—	0.45	—	0.70	
		I <sub>OL</sub> = 8mA	2.3V	—	0.3	—	0.45	
		I <sub>OL</sub> = 16mA	3V	—	0.4	—	0.60	
		I <sub>OL</sub> = 24mA		—	0.55	—	0.80	
		I <sub>OL</sub> = 32mA	4.5V	—	0.55	—	0.80	
I <sub>I</sub>	Input Current	V <sub>I</sub> = 5.5V or GND	0 to 5.5V	—	± 5	—	± 20	µA
I <sub>OZ</sub>	Z State Leakage Current	V <sub>O</sub> = 0 to 5.5V	3.6V	—	± 10	—	± 10	µA
I <sub>OFF</sub>	Power Down Leakage Current	V <sub>I</sub> or V <sub>O</sub> = 5.5V	0V	—	± 10	—	± 20	µA
I <sub>CC</sub>	Supply Current	V <sub>I</sub> = 5.5V or GND, I <sub>O</sub> = 0	1.65V to 5.5V	—	10	—	40	µA
ΔI <sub>CC</sub>	Additional Supply Current	Input at V <sub>CC</sub> -0.6V	3V to 5.5V	—	500	—	5000	µA

### Package Characteristics (All typical values are at V<sub>CC</sub> = 3.3V, T<sub>A</sub> = +25°C.)

Symbol	Parameter	Package	Conditions	Min	Typ	Max	Unit
C <sub>I</sub>	Input Capacitance	Typical of All Packages	V <sub>CC</sub> = 3.3V V <sub>I</sub> = V <sub>CC</sub> or GND	—	3.5	—	pF
θ <sub>JA</sub>	Thermal Resistance Junction-to-Ambient	SOT26	(Note 9)	—	204	—	°C/W
		SOT363		—	371	—	
		X2-DFN1410-6		—	430	—	
		X2-DFN1409-6		—	450	—	
		X1-DFN1010-6		—	495	—	
		X2-DFN1010-6		—	510	—	
θ <sub>JC</sub>	Thermal Resistance Junction-to-Case	SOT26	(Note 9)	—	52	—	°C/W
		SOT363		—	143	—	
		X2-DFN1410-6		—	190	—	
		X2-DFN1409-6		—	225	—	
		X1-DFN1010-6		—	245	—	
		X2-DFN1010-6		—	250	—	

Note: 9. Test condition for all packages: Device mounted on FR-4 substrate PC board, 2oz copper with minimum recommended pad layout.

### Switching Characteristics

T<sub>A</sub> = -40°C to +85°C, C<sub>L</sub> = 30 or 50pF (See Figure 1)

Parameter	From (Input)	TO (OUTPUT)	V <sub>CC</sub> = 1.8V ± 0.15V		V <sub>CC</sub> = 2.5V ± 0.2V		V <sub>CC</sub> = 3.3V ± 0.3V		V <sub>CC</sub> = 5V ± 0.5V		Unit
			Min	Max	Min	Max	Min	Max	Min	Max	
t <sub>pd</sub>	A	Y	0.5	6.5	0.5	3.9	0.5	3.4	0.5	2.9	ns

T<sub>A</sub> = -40°C to +125°C, C<sub>L</sub> = 30 or 50pF (See Figure 1)

Parameter	From (Input)	TO (OUTPUT)	V <sub>CC</sub> = 1.8V ± 0.15V		V <sub>CC</sub> = 2.5V ± 0.2V		V <sub>CC</sub> = 3.3V ± 0.3V		V <sub>CC</sub> = 5V ± 0.5V		Unit
			Min	Max	Min	Max	Min	Max	Min	Max	
t <sub>pd</sub>	A	Y	0.5	8.2	0.5	4.9	0.5	4.3	0.5	3.7	ns

**Operating Characteristics**

T<sub>A</sub> = +25°C

Parameter	Test Conditions	V <sub>CC</sub> = 1.8V	V <sub>CC</sub> = 2.5V	V <sub>CC</sub> = 3.3V	V <sub>CC</sub> = 5V	Unit
		Typ	Typ	Typ	Typ	
C <sub>pd</sub>	Power Dissipation Capacitance f = 10 MHz	3	3	4	6	pF

**Parameter Measurement Information**

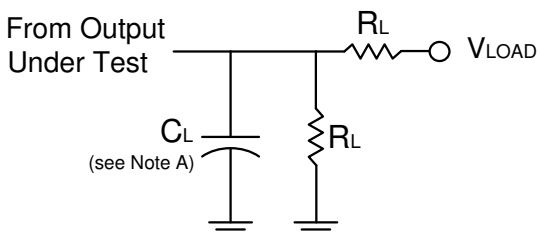

TEST	Condition
t <sub>PLZ</sub> (See Notes D and E)	V <sub>load</sub>
t <sub>PZL</sub> (See Notes D and F)	V <sub>load</sub>

V <sub>CC</sub>	Inputs		V <sub>M</sub>	V <sub>LOAD</sub>	C <sub>L</sub>	R <sub>L</sub>	V <sub>Δ</sub>
	V <sub>I</sub>	t <sub>r</sub> /t <sub>f</sub>					
1.8V±0.15V	V <sub>CC</sub>	≤2ns	V <sub>CC</sub> /2	2 X V <sub>CC</sub>	30pF	1kΩ	0.15V
2.5V±0.2V	V <sub>CC</sub>	≤2ns	V <sub>CC</sub> /2	2 X V <sub>CC</sub>	30pF	500Ω	0.15V
3.3V±0.3V	3V	≤2.5ns	1.5 V	6 V	50pF	500Ω	0.3V
5V±0.5V	V <sub>CC</sub>	≤2.5ns	V <sub>CC</sub> /2	2 X V <sub>CC</sub>	50pF	500Ω	0.3V

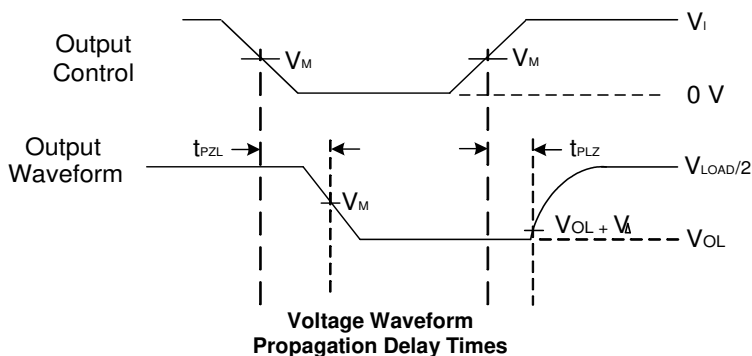
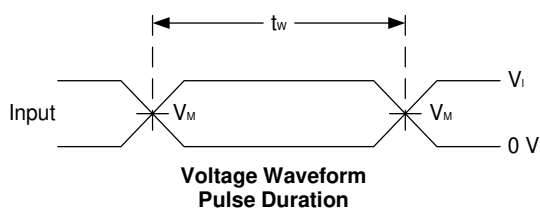
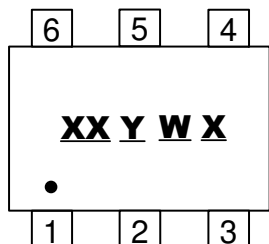

**Figure 1 Load Circuit and Voltage Waveforms**

- Notes:
- A. Includes test lead and test apparatus capacitance.
  - B. All pulses are supplied at pulse repetition rate ≤ 10 MHz
  - C. The inputs are measured one at a time with one transition per measurement.
  - D. For the open drain device t<sub>PLZ</sub> and t<sub>PZL</sub> are the same as t<sub>PD</sub>.
  - E. t<sub>PZL</sub> is measured at V<sub>M</sub>.
  - F. t<sub>PLZ</sub> is measured at V<sub>OL</sub> + V<sub>Δ</sub>.

**Marking Information**

(1) SOT26, SOT363



XX : Identification code  
Y : Year 0~9  
W : Week : A~Z : 1~26 week;  
 a~z : 27~52 week; z represents  
 52 and 53 week  
X : A~Z : Internal Code

Part Number	Package	Identification Code
74LVC2G06W6-7	SOT26	Z3
74LVC2G06DW-7	SOT363	Z3

(2) X1-DFN1010-6, X2-DFN1010-6, X2-DFN1409-6, X2-DFN1410-6

**(Top View)**

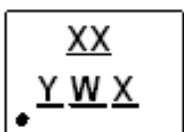

XX : Identification Code  
Y : Year : 0~9  
W : Week : A~Z : 1~26 week;  
 a~z : 27~52 week; z represents  
 52 and 53 week  
X : A~Z : Internal code

Part Number	Package	Identification Code
74LVC2G06FW4-7	X2-DFN1010-6	Z3
74LVC2G06FW5-7	X1-DFN1010-6	W3
74LVC2G06FX4-7	X2-DFN1409-6	X3
74LVC2G06FZ4-7	X2-DFN1410-6	Z3

**SOT26 Package Outline Dimensions and Suggested Pad Layout**

Please see AP02002 at <http://www.diodes.com/datasheets/ap02002.pdf> for the latest version.

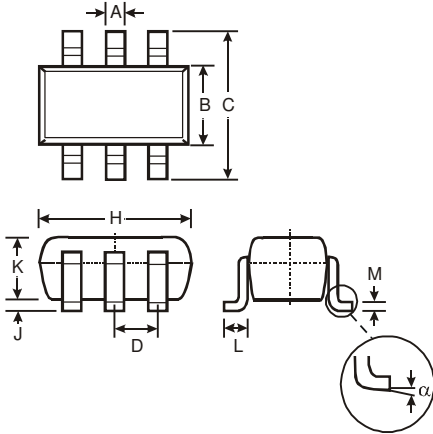

SOT26			
Dim	Min	Max	Typ
A	0.35	0.50	0.38
B	1.50	1.70	1.60
C	2.70	3.00	2.80
D	—	—	0.95
H	2.90	3.10	3.00
J	0.013	0.10	0.05
K	1.00	1.30	1.10
L	0.35	0.55	0.40
M	0.10	0.20	0.15
α	0°	8°	—
All Dimensions in mm			

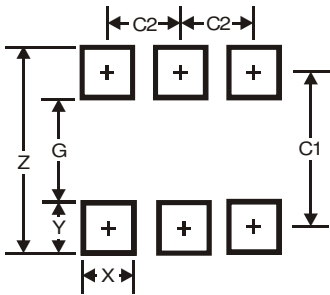

Dimensions	Value (in mm)
Z	3.20
G	1.60
X	0.55
Y	0.80
C1	2.40
C2	0.95

**SOT363 Package Outline Dimensions and Suggested Pad Layout**

Please see AP02002 at <http://www.diodes.com/datasheets/ap02002.pdf> for the latest version.

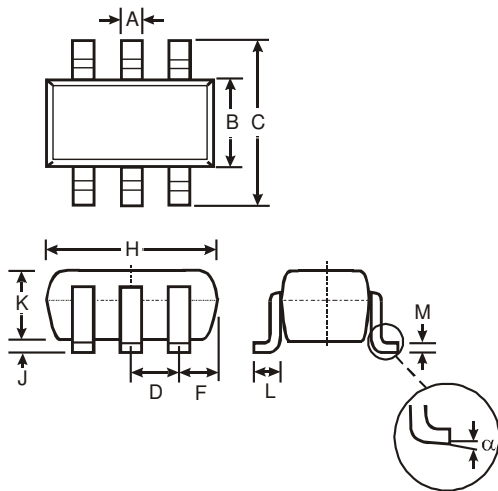

SOT363			
Dim	Min	Max	Typ
A	0.10	0.30	0.25
B	1.15	1.35	1.30
C	2.00	2.20	2.10
D	0.65 Typ		
F	0.40	0.45	0.425
H	1.80	2.20	2.15
J	0	0.10	0.05
K	0.90	1.00	1.00
L	0.25	0.40	0.30
M	0.10	0.22	0.11
α	0°	8°	-
<b>All Dimensions in mm</b>			

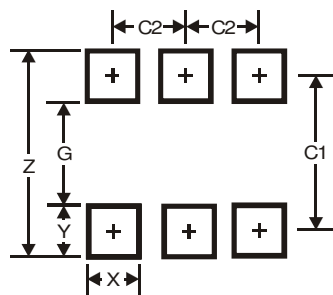

Dimensions	Value (in mm)
Z	2.5
G	1.3
X	0.42
Y	0.6
C1	1.9
C2	0.65



**X1-DFN1010-6 (Type B) Package Outline Dimensions and Suggested Pad Layout**

Please see AP02002 at <http://www.diodes.com/datasheets/ap02002.pdf> for the latest version.

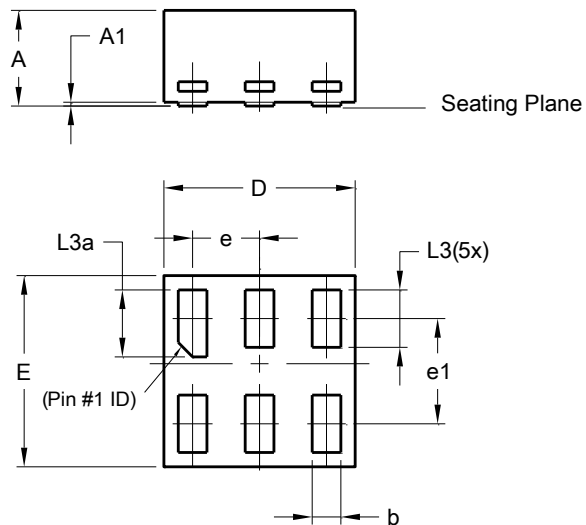

X1-DFN1010-6 (Type B)			
Dim	Min	Max	Typ
A	-	0.50	0.39
A1	-	0.04	-
b	0.12	0.20	0.15
D	0.95	1.050	1.00
E	0.95	1.050	1.00
e	0.35 BSC		
e1	0.55 BSC		
L3	0.27	0.30	0.30
L3a	0.32	0.40	0.35
All Dimensions in mm			

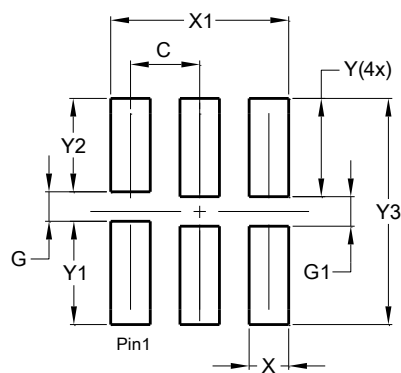

Dimensions	Value (in mm)
C	0.350
G	0.150
G1	0.150
X	0.200
X1	0.900
Y	0.500
Y1	0.525
Y2	0.475
Y3	1.150

**X2-DFN1010-6 Package Outline Dimensions and Suggested Pad Layout**

Please see AP02002 at <http://www.diodes.com/datasheets/ap02002.pdf> for latest version.

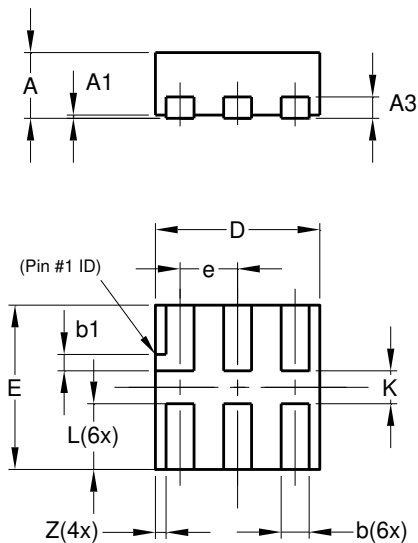

X2-DFN1010-6			
Dim	Min	Max	Typ
A	—	0.40	0.39
A1	0.00	0.05	0.02
A3	—	—	0.13
b	0.14	0.20	0.17
b1	0.05	0.15	0.10
D	0.95	1.05	1.00
E	0.95	1.05	1.00
e	—	—	0.35
L	0.35	0.45	0.40
K	0.15	—	—
Z	—	—	0.065
All Dimensions in mm			

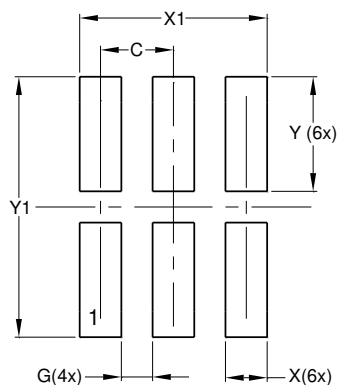

Dimensions	Value (in mm)
C	0.350
G	0.150
X	0.200
X1	0.900
Y	0.550
Y1	1.250

**X2-DFN1409-6 Package Outline Dimensions and Suggested Pad Layout**

Please see AP02002 at <http://www.diodes.com/datasheets/ap02002.pdf> for the latest version.

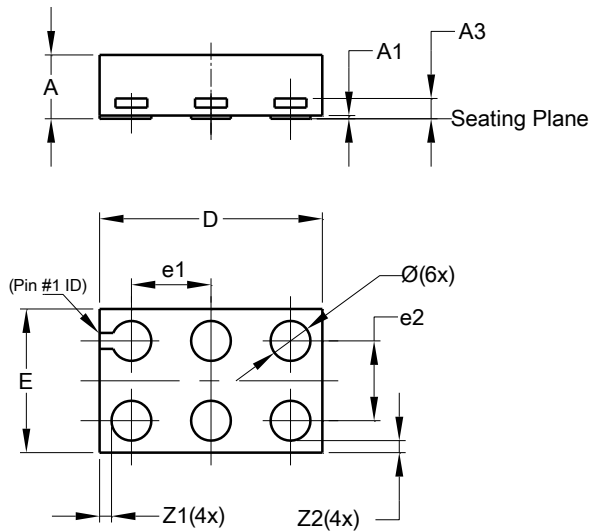

X2-DFN1409-6			
Dim	Min	Max	Typ
A	—	0.40	0.39
A1	0	0.05	0.02
A3	—	—	0.13
Ø	0.20	0.30	0.25
D	1.35	1.45	1.40
E	0.85	0.95	0.90
e1	—	—	0.50
e2	—	—	0.50
Z1	—	—	0.075
Z2	—	—	0.075
All Dimensions in mm			

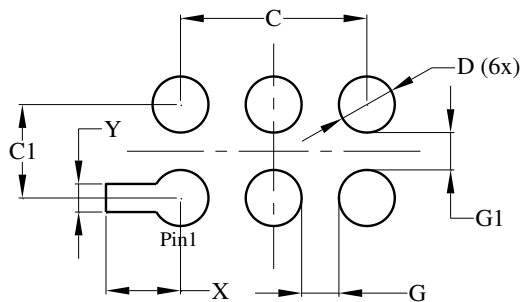

Dimensions	Value (in mm)
C	1.000
C1	0.500
D	0.300
G	0.200
G1	0.200
X	0.400
Y	0.150

**X2-DFN1410-6 Package Outline Dimensions and Suggested Pad Layout**

Please see AP02002 at <http://www.diodes.com/datasheets/ap02002.pdf> for the latest version.

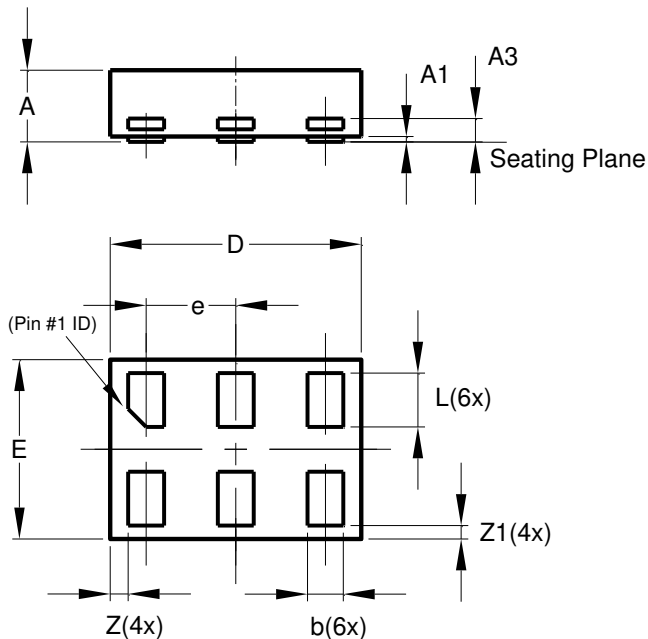

X2-DFN1410-6			
Dim	Min	Max	Typ
A	—	0.40	0.39
A1	0.00	0.05	0.02
A3	—	—	0.13
b	0.15	0.25	0.20
D	1.35	1.45	1.40
E	0.95	1.05	1.00
e	—	—	0.50
L	0.25	0.35	0.30
Z	—	—	0.10
Z1	0.045	0.105	0.075
All Dimensions in mm			

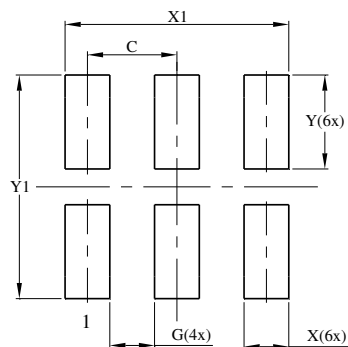

Dimensions	Value (in mm)
C	0.500
G	0.250
X	0.250
X1	1.250
Y	0.525
Y1	1.250

**IMPORTANT NOTICE**

DIODES INCORPORATED MAKES NO WARRANTY OF ANY KIND, EXPRESS OR IMPLIED, WITH REGARDS TO THIS DOCUMENT, INCLUDING, BUT NOT LIMITED TO, THE IMPLIED WARRANTIES OF MERCHANTABILITY AND FITNESS FOR A PARTICULAR PURPOSE (AND THEIR EQUIVALENTS UNDER THE LAWS OF ANY JURISDICTION).

Diodes Incorporated and its subsidiaries reserve the right to make modifications, enhancements, improvements, corrections or other changes without further notice to this document and any product described herein. Diodes Incorporated does not assume any liability arising out of the application or use of this document or any product described herein; neither does Diodes Incorporated convey any license under its patent or trademark rights, nor the rights of others. Any Customer or user of this document or products described herein in such applications shall assume all risks of such use and will agree to hold Diodes Incorporated and all the companies whose products are represented on Diodes Incorporated website, harmless against all damages.

Diodes Incorporated does not warrant or accept any liability whatsoever in respect of any products purchased through unauthorized sales channel. Should Customers purchase or use Diodes Incorporated products for any unintended or unauthorized application, Customers shall indemnify and hold Diodes Incorporated and its representatives harmless against all claims, damages, expenses, and attorney fees arising out of, directly or indirectly, any claim of personal injury or death associated with such unintended or unauthorized application.

Products described herein may be covered by one or more United States, international or foreign patents pending. Product names and markings noted herein may also be covered by one or more United States, international or foreign trademarks.

This document is written in English but may be translated into multiple languages for reference. Only the English version of this document is the final and determinative format released by Diodes Incorporated.

**LIFE SUPPORT**

Diodes Incorporated products are specifically not authorized for use as critical components in life support devices or systems without the express written approval of the Chief Executive Officer of Diodes Incorporated. As used herein:

A. Life support devices or systems are devices or systems which:

1. are intended to implant into the body, or
2. support or sustain life and whose failure to perform when properly used in accordance with instructions for use provided in the labeling can be reasonably expected to result in significant injury to the user.

B. A critical component is any component in a life support device or system whose failure to perform can be reasonably expected to cause the failure of the life support device or to affect its safety or effectiveness.

Customers represent that they have all necessary expertise in the safety and regulatory ramifications of their life support devices or systems, and acknowledge and agree that they are solely responsible for all legal, regulatory and safety-related requirements concerning their products and any use of Diodes Incorporated products in such safety-critical, life support devices or systems, notwithstanding any devices- or systems-related information or support that may be provided by Diodes Incorporated. Further, Customers must fully indemnify Diodes Incorporated and its representatives against any damages arising out of the use of Diodes Incorporated products in such safety-critical, life support devices or systems.

Copyright © 2015, Diodes Incorporated

[www.diodes.com](http://www.diodes.com)