

FMS6246

Six Channel, 6th Order SD/PS Video Filter Driver

Features

- Three selectable sixth-order 8/15MHz (SD/PS) filters
- Three fixed sixth-order 8MHz (SD) filters
- Transparent input clamping
- Single video load drive ($2V_{pp}$, 150Ω , $A_V = 6dB$)
- AC or DC-coupled inputs
- AC or DC-coupled outputs
- DC-coupled outputs eliminate AC-coupling capacitors
- Low power
- 5V only
- Robust (12kV HBM) output ESD protection
- Lead (Pb) free packages- TSSOP-20

Applications

- Cable and satellite set-top boxes
- DVD players
- HDTV
- Personal Video Recorders (PVR)
- Video On Demand (VOD)

Description

The FMS6246 Low Cost Video Filter (LCVF) is intended to replace passive LC filters and drivers with a low-cost integrated device. Six 6th order Butterworth filters provide improved image quality compared to typical passive solutions. The combination of low power Standard Definition (SD) and Progressive Scan (PS) filters greatly simplify DVD video output circuitry. Three channels offer fixed SD filters while the other three are selectable between SD and PS filters.

The FMS6246 offers a fixed gain of 6dB. A metal option is available that provides a fixed gain of 9dB, offering even more flexibility.

The FMS6246 may be directly driven by a DC-coupled DAC output or an AC-coupled signal. Internal diode clamps and bias circuitry may be used if AC-coupled inputs are required (see applications section for details).

The outputs can drive AC or DC-coupled single (150Ω) video loads. DC-coupling the outputs removes the need for output coupling capacitors. The input DC levels will be offset approximately +280mV at the output.

Block Diagram

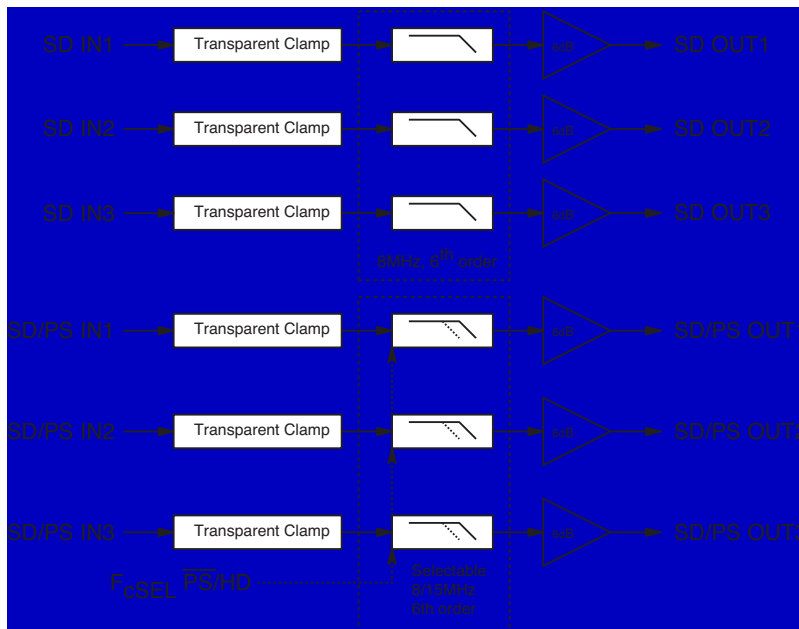

Pin Configuration

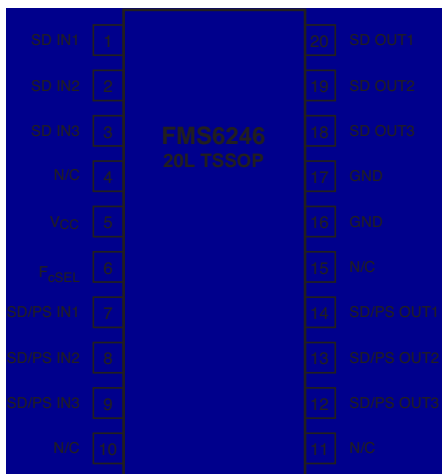

Pin Assignments

Pin #	Pin	Type	Description
1	SD IN1	Input	SD video input, channel 1
2	SD IN2	Input	SD video input, channel 2
3	SD IN3	Input	SD video input, channel 3
4	N/C	Input	No Connect
5	VCC	Input	+5V supply
6	FcSEL	Input	Selects filter corner frequency for pins 7, 8, and 9. "0" = SD, "1" = PS
7	SD/PS IN1	Input	Selectable SD or PS video input, channel 1
8	SD/PS IN2	Input	Selectable SD or PS video input, channel 2
9	SD/PS IN3	Input	Selectable SD or PS video input, channel 3
10	N/C	Input	No Connect
11	N/C	Input	No Connect
12	SD/PS OUT3	Output	Filtered SD or PS video output, channel 3
13	SD/PS OUT2	Output	Filtered SD or PS video output, channel 2
14	SD/PS OUT1	Output	Filtered SD or PS video output, channel 1
15	N/C	Input	No Connect
16	GND	Input	Must be tied to Ground
17	GND	Input	Must be tied to Ground
18	SD OUT3	Output	Filtered SD video output, channel 3
19	SD OUT2	Output	Filtered SD video output, channel 2
20	SD OUT1	Output	Filtered SD video output, channel 1

Factory Programming Options

Part Name	Part Number	Gain Option
FMS6246	FMS6246MTC20	6dB
FMS6246-9	FMS6246MTC209	9dB

Absolute Maximum Ratings

Parameter	Min	Max	Unit
DC Supply Voltage	-0.3	6	V
Analog and Digital I/O	-0.3	$V_{CC} + 0.3$	V
Output Current, Any One Channel (Do Not Exceed)		50	mA

Reliability Information

Parameter	Min	Typ	Max	Unit
Junction Temperature			150	°C
Storage Temperature Range	-65		150	°C
Lead Temperature (Soldering, 10s)			300	°C
Thermal Resistance (θ_{JA}), JEDEC Standard Multi-Layer Test Boards, Still Air		74		°C/W

Recommended Operating Conditions

Parameter	Min	Typ	Max	Unit
Operating Temperature Range	0		70	°C
Supply Voltage Range	4.75	5.0	5.25	V

DC Electrical Characteristics

$T_c = 25^\circ\text{C}$, $V_{cc} = 5\text{V}$, $R_{source} = 37.5\Omega$, inputs AC coupled with $0.1\mu\text{F}$, all outputs AC coupled with $220\mu\text{F}$ into 150Ω loads, referenced to 400kHz ; unless otherwise noted.

Symbol	Parameter	Conditions	Min	Typ	Max	Units
I_{CC}	Supply Current ¹	no load		60	80	mA
V_{in}	Video Input Voltage Range	Referenced to GND, if DC-coupled		1.4		V _{pp}
V_{il}	Digital Input Low ¹	F_{cSEL}	0		0.8	V
V_{ih}	Digital Input High ¹	F_{cSEL}	2.4		V_{cc}	V

Standard Definition Electrical Characteristics

$T_c = 25^\circ\text{C}$, $V_{in} = 1V_{pp}$, $V_{cc} = 5\text{V}$, $R_{source} = 37.5\Omega$, all inputs AC coupled with $0.1\mu\text{F}$, all outputs AC coupled with $220\mu\text{F}$ into 150Ω loads, referenced to 400kHz ; unless otherwise noted.

Symbol	Parameter	Conditions	Min	Typ	Max	Units
AV_{SD}	Channel Gain ¹	All SD Channels	5.6	6.0	6.4	dB
f_{1dBSD}	-1dB Bandwidth ¹	All SD Channels	5.2	7.15		MHz
f_{cSD}	-3dB Bandwidth ¹	All SD Channels	6.5	8.0		MHz
f_{SBSD}	Attenuation(stopband reject) ¹	All SD Channels at $f = 27\text{MHz}$	43	50		dB
DG	Differential Gain	All SD Channels		0.7		%
DP	Differential Phase	All SD Channels		1.0		°
THD	Output Distortion	$V_{OUT} = 1.4V_{pp}$, 3.58MHz		0.35		%
X_{TALKSD}	Crosstalk (ch-to-ch)	at 1MHz		-54		dB
SNR	Signal-to-Noise Ratio ²	NTC-7 weighting, 100kHz to 4.2MHz		72		dB
t_{pdSD}	Propagation Delay	Delay from input to output, 4.5MHz		90		ns

Progressive Scan Electrical Characteristics

$T_c = 25^\circ\text{C}$, $V_{in} = 1V_{pp}$, $V_{cc} = 5\text{V}$, $R_{source} = 37.5\Omega$, $F_{cSEL} = 0$, all inputs AC coupled with $0.1\mu\text{F}$, all outputs AC coupled with $220\mu\text{F}$ into 150Ω loads, referenced to 400kHz ; unless otherwise noted.

Symbol	Parameter	Conditions	Min	Typ	Max	Units
AV_{PS}	Channel Gain ¹	All PS Channels	5.6	6.0	6.4	dB
f_{1dBSPS}	-1dB Bandwidth ¹	All PS Channels	12	14		MHz
f_{cPS}	-3dB Bandwidth ¹	All PS Channels	13	16		MHz
f_{SBPS}	Attenuation(stopband reject) ¹	All PS Channels at $f = 54\text{MHz}$	37	45		dB
THD	Output Distortion (All PS channels)	$V_{OUT} = 1.4V_{pp}$, 7MHz		0.35		%
X_{TALKPS}	Crosstalk (ch-to-ch)	at 1MHz		-53		dB
SNR	Signal-to-Noise Ratio ²	unweighted; 100kHz to 15MHz		66		dB
t_{pdPS}	Propagation Delay	Delay from input to output		47		ns

Notes:

- 100% tested at 25°C
- $SNR = 20 * \log(714\text{mV}/\text{rms noise})$

Typical Performance Characteristics

$T_c = 25^\circ\text{C}$, $V_{in} = 1V_{pp}$, $V_{CC} = 5V$, $R_{source} = 37.5\Omega$, inputs AC coupled with $0.1\mu\text{F}$, all outputs AC coupled with $220\mu\text{F}$ into 150Ω loads; unless otherwise noted.

Figure 1. SD Gain vs. Frequency

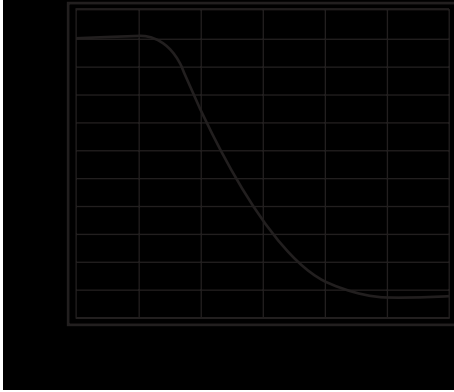

Figure 2. SD Flatness vs. Frequency

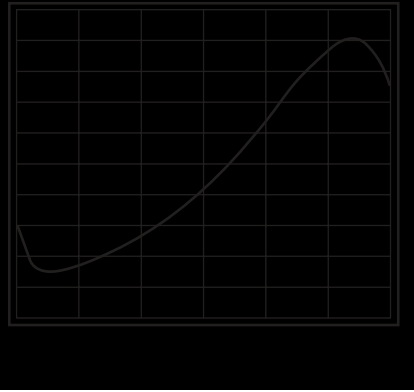

Figure 3. PS Gain vs. Frequency

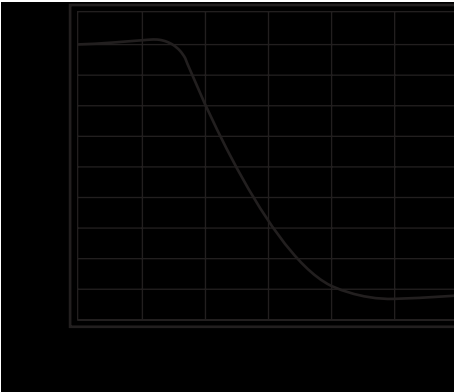

Figure 4. PS Flatness vs. Frequency

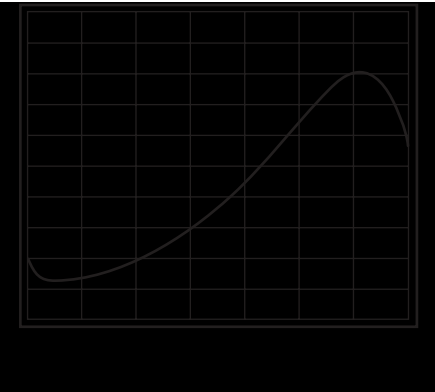

Figure 5. SD Group Delay vs. Frequency

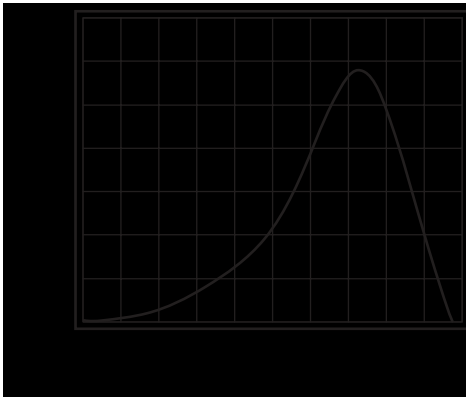
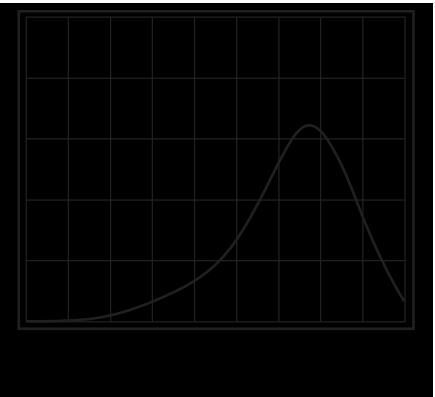

Figure 6. PS Group Delay vs. Frequency



Typical Performance Characteristics

$T_c = 25^\circ\text{C}$, $V_{in} = 1V_{pp}$, $V_{CC} = 5V$, $R_{source} = 37.5\Omega$, inputs AC coupled with $0.1\mu\text{F}$, all outputs AC coupled with $220\mu\text{F}$ into 150Ω loads; unless otherwise noted.

Figure 7. SD Differential Gain

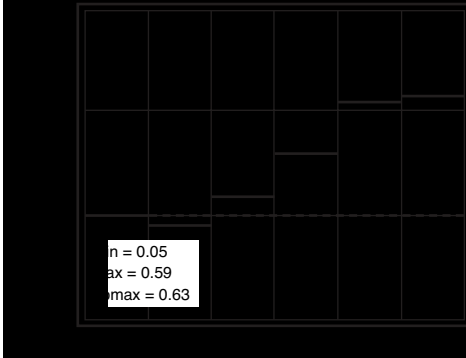
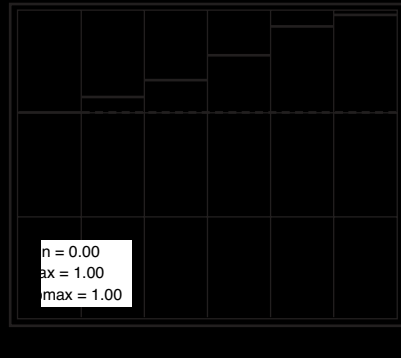

Figure 8. SD Differential Phase



Applications Information

Functional Description

The FMS6246 Low Cost Video Filter (LCVF) provides 6dB gain (9dB optional, contact factory for further information) from input to output. In addition, the input will be slightly offset to optimize the output driver performance. The offset is held to the minimum required value to decrease the standing DC current into the load. Typical voltage levels are shown in the diagram below.

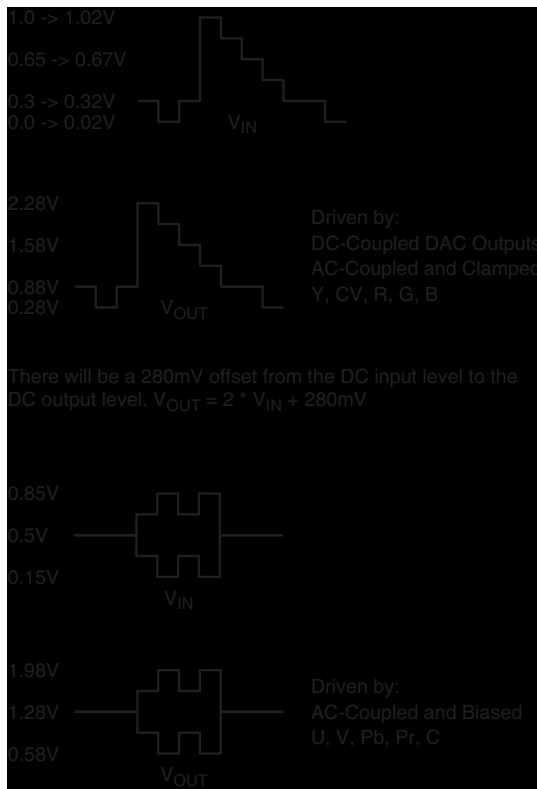

Figure 9. Typical Voltage Levels

The FMS6246 provides an internal diode clamp to support AC-coupled input signals. If the input signal does not go below ground, the input clamp will not operate. This allows DAC outputs to directly drive the FMS6246 without an AC coupling capacitor. The worst-case sync tip compression due to the clamp will not exceed 7mV. The input level set by the clamp combined with the internal DC offset will keep the output within its acceptable range. When the input is AC-coupled, the diode clamp will set the sync tip (or lowest voltage) just below ground.

For symmetric signals like C, U, V, Cb, Cr, Pb and Pr, the average DC bias is fairly constant and the inputs can be AC-coupled with the addition of a pull-up resistor to set the DC input voltage. DAC outputs can also drive these same signals without the AC coupling capacitor. A conceptual illustration of the input clamp circuit is shown below:

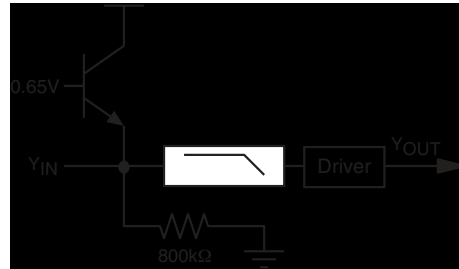

Figure 10. Input Clamp Circuit

I/O Configurations

For DC-coupled DAC drive with DC-coupled outputs, use this configuration:

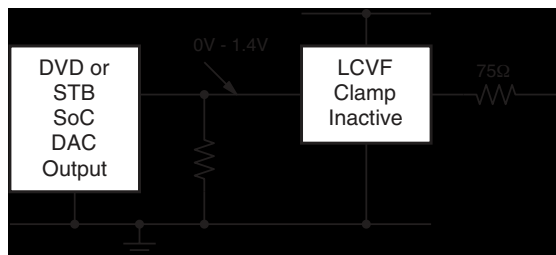

Figure 11. DC-coupled Inputs and Outputs

Alternatively, if the DAC's average DC output level causes the signal to exceed the range of 0V to 1.4V, it can be AC-coupled as follows:

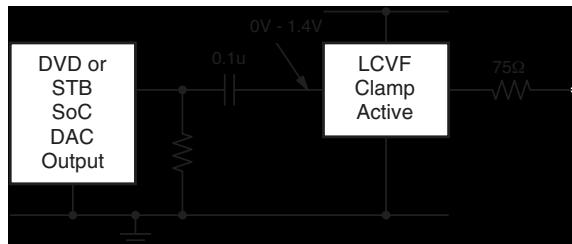

Figure 12. AC-coupled Inputs, DC-coupled Outputs

When the FMS6246 is driven by an unknown external source or a SCART switch with its own clamping circuitry, the inputs should be AC-coupled as follows:

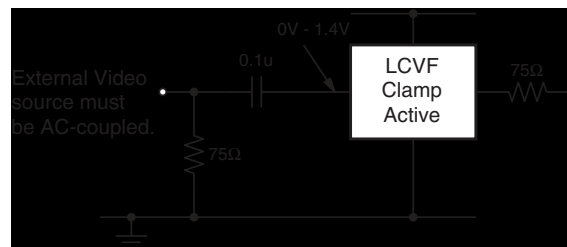

Figure 13. SCART Configuration with DC-coupled Outputs

The same method can be used for biased signals with the addition of a pull-up resistor to make sure the clamp never operates. The internal pull-down resistance is $800k\Omega \pm 20\%$ so the external resistance should be $7.5M\Omega$ to set the DC level to $500mV$. If a pull-up resistance less than $7.5M\Omega$ is desired, an external pull-down can be added such that the DC input level is set to $500mV$.

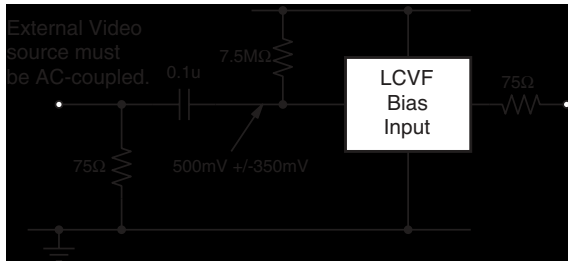

Figure 14. Biased SCART with DC-coupled Outputs

The same circuits can be used with AC-coupled outputs if desired.

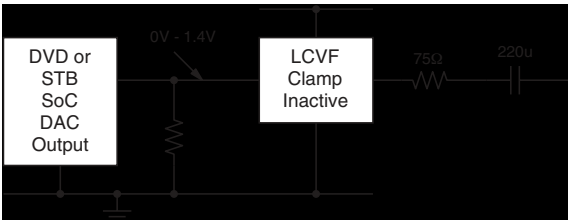

Figure 15. DC-coupled Inputs, AC-coupled Outputs

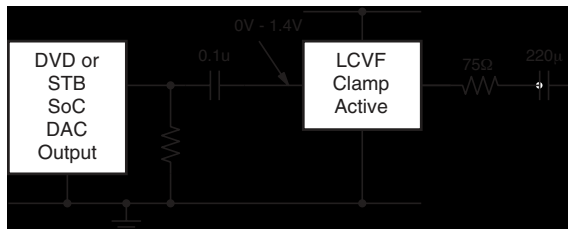

Figure 16. AC-coupled Inputs, AC-coupled Outputs

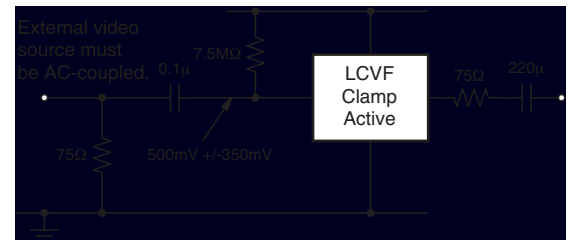

Figure 17. Biased SCART with AC-coupled Outputs

NOTE: The video tilt or line time distortion will be dominated by the AC-coupling capacitor. The value may need to be increased beyond $220\mu F$ in order to obtain satisfactory operation in some applications.

Power Dissipation

The FMS6246 output drive configuration must be considered when calculating overall power dissipation. Care must be taken not to exceed the maximum die junction temperature. The following example can be used to calculate the FMS6246's power dissipation and internal temperature rise.

$$T_j = T_A + P_d \cdot \theta_{JA}$$

where $P_d = P_{CH1} + P_{CH2} + P_{CHx}$

$$\text{and } P_{CHx} = V_s \cdot I_{CH} - (V_O^2/R_L)$$

where

$$V_O = 2V_{in} + 0.280V$$

$$I_{CH} = (I_{CC} / 6) + (V_O/R_L)$$

V_{in} = RMS value of input signal

$$I_{CC} = 60mA$$

$$V_s = 5V$$

R_L = channel load resistance

Board layout can also affect thermal characteristics. Refer to the *Layout Considerations* Section for more information.

Layout Considerations

General layout and supply bypassing play major roles in high frequency performance and thermal characteristics. Fairchild offers a demonstration board, FMS6246DEMO, to use as a guide for layout and to aid in device testing and characterization. The FMS6246DEMO is a 4-layer board with a full power and ground plane. Following this layout configuration will provide the optimum performance and thermal characteristics. For optimum results, follow the steps below as a basis for high frequency layout:

- Include $10\mu F$ and $0.1\mu F$ ceramic bypass capacitors
- Place the $10\mu F$ capacitor within 0.75 inches of the power pin
- Place the $0.1\mu F$ capacitor within 0.1 inches of the power pin
- For multi-layer boards, use a large ground plane to help dissipate heat
- For 2 layer boards, use a ground plane that extends beyond the device by at least 0.5"
- Minimize all trace lengths to reduce series inductances

Typical Application Diagram

The following circuit may be used for direct DC-coupled drive by DACs with an output voltage range of 0V to 1.4V. AC-coupled or DC-coupled outputs may be used with AC-coupled outputs offering slightly lower power dissipation.

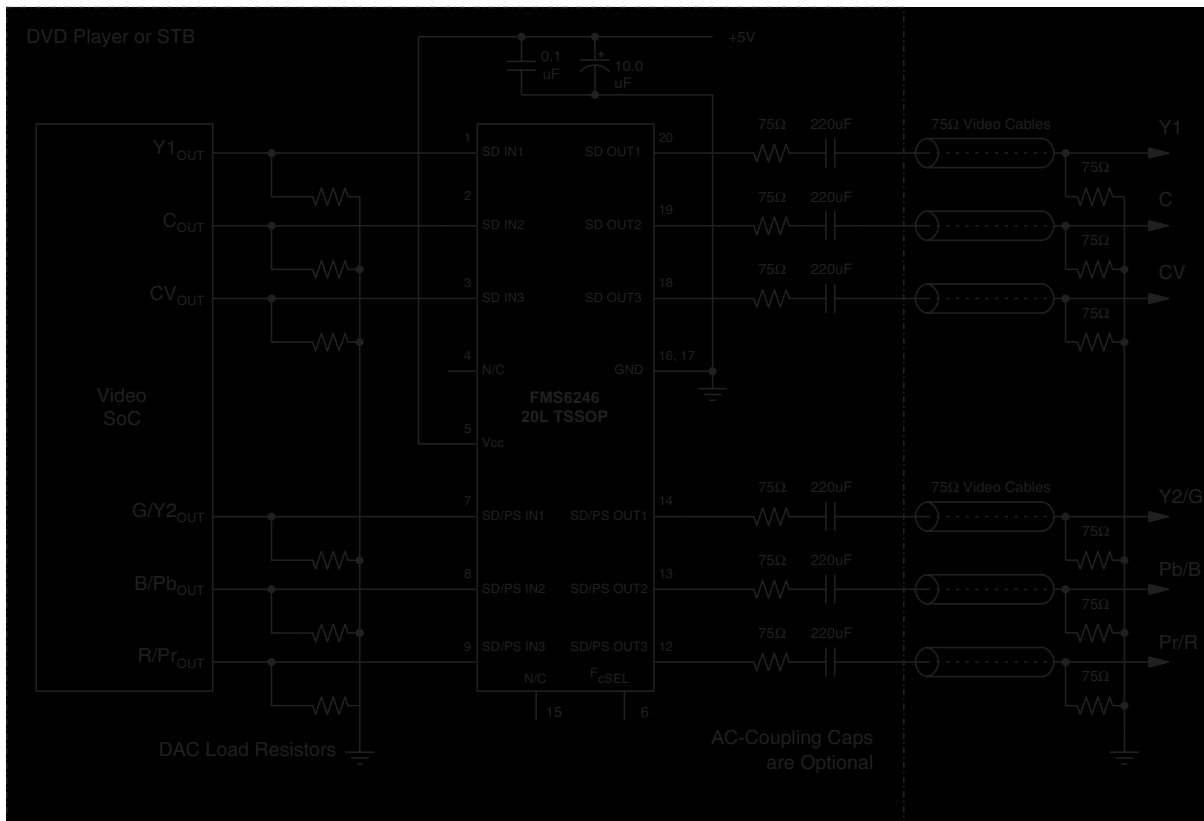
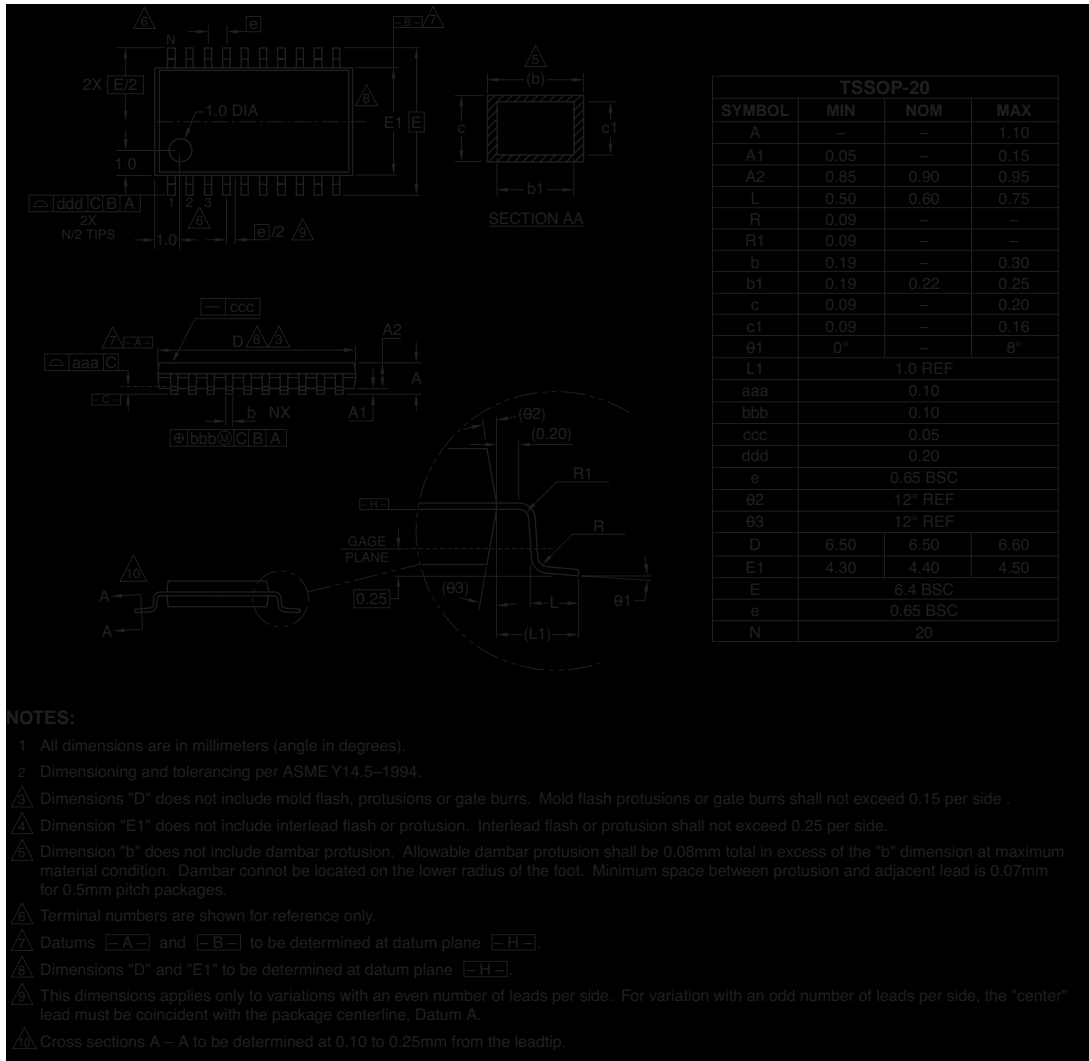

Figure 18. Typical Application Diagram

Mechanical Dimensions

20-Lead Thin Shrink Outline Package (TSSOP)



Ordering Information

Model	Part Number	Gain Option	Lead Free	Package	Container	Pack Qty
FMS6246	FMS6246MTC20	6dB	Yes	TSSOP-20	Rail	94
FMS6246	FMS6246MTC20X	6dB	Yes	TSSOP-20	Reel	2500

Temperature range for all parts: 0°C to 70°C.

Contact Fairchild for additional gain options. Refer to the Factory Programming Options table for more information.

